

Alfa Laval LKB and LKB-F

Butterfly valves

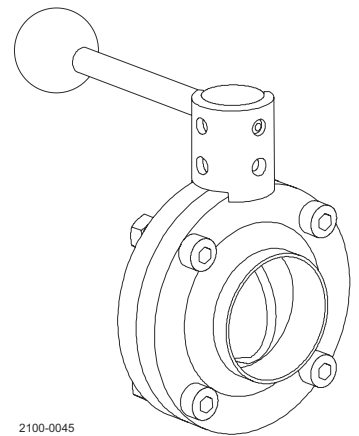
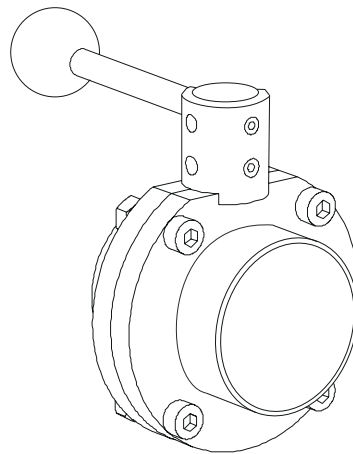
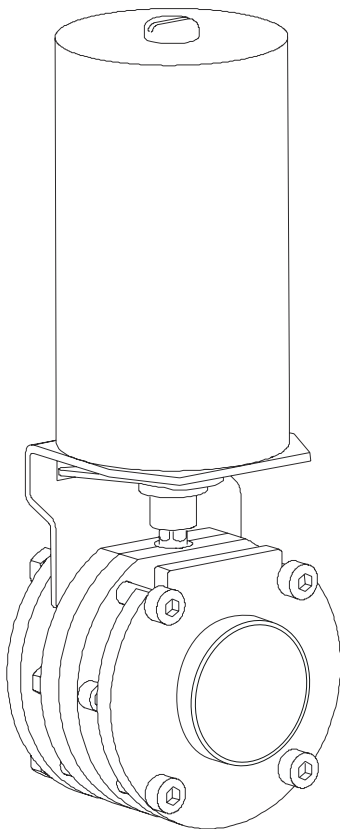

Lit. Code

200007926-3-EN-GB

Instruction Manual

Published by
Alfa Laval Kolding A/S
Albuen 31
DK-6000 Kolding, Denmark
+45 79 32 22 00

The original instructions are in English

© Alfa Laval AB 2026-04

This document and its contents are subject to copyrights and other intellectual property rights owned by Alfa Laval AB (publ) or any of its affiliates (jointly "Alfa Laval"). No part of this document may be copied, re-produced or transmitted in any form or by any means, or for any purpose, without Alfa Laval's prior express written permission. Information and services provided in this document are made as a benefit and service to the user, and no representations or warranties are made about the accuracy or suitability of this information and these services for any purpose. All rights are reserved.

Contents

1	Declarations of Conformity	5
1.1	EU Declaration of Conformity.....	5
1.2	UK Declaration of Conformity.....	6
2	Safety	7
2.1	Safety Signs.....	8
2.2	Safety Precautions.....	10
2.3	Warning Signs in Text.....	15
2.4	Requirements of Personnel.....	16
2.5	Recycling Information.....	17
3	Introduction — LKB/LKB-F	19
4	Installation	21
4.1	Unpacking/Delivery.....	21
4.2	General installation.....	23
4.3	Welding.....	25
4.4	Fitting Actuator/Bracket/Handle on the Valve (Optional Extras).....	27
5	Operation	29
5.1	Operation.....	29
5.2	Troubleshooting.....	31
5.3	Recommended Cleaning.....	32
6	Maintenance	33
6.1	General maintenance.....	33
6.2	Dismantling the valve — LKB/LKB-2/LKB-LP.....	36
6.3	Valve assembly — LKB/LKB-2/LKB-LP.....	37
6.4	Dismantling the Valve — LKB-F.....	39
6.5	Valve assembly — LKB-F.....	41
6.6	Dismantling of Actuator.....	43
6.7	Assembly of Actuator.....	44
7	Technical Data	47
7.1	Technical Data.....	47
7.2	Physical Data — LKB/LKB-F.....	48
7.3	Weight.....	49
7.4	Noise.....	49
8	Spare Parts	51
8.1	Ordering Spare Parts.....	51

8.2	Alfa Laval Service.....	51
8.3	Warranty - Definition.....	52
9	Parts Lists and Exploded Views.....	53
9.1	Drawings.....	53
9.2	LKB Butterfly Valve, ISO.....	56
9.3	LKB-F Butterfly Valve, ISO.....	57
9.4	LKB-F Butterfly Valve, DIN.....	58
9.5	LKB-2 Butterfly Valve.....	59
9.6	LKB-LP Butterfly Valve.....	60
9.7	LKB lockable multiposition handle for valve.....	62
9.8	LKB handle 1.1 for Butterfly Valve.....	63
9.9	Handle 1.1 for indication unit.....	64
9.10	LKLA actuator air/spring (NC-NO) Ø85.....	65
9.11	LKLA actuator air/air Ø85.....	66
9.12	LKLA, DN 125-150, ø85 mm (A/A).....	67
9.13	LKLA actuator air/spring (NC-NO) Ø133.....	68
9.14	LKLA actuator air/air Ø133.....	69
9.15	LKLA-T actuator air/spring (NC-NO) Ø85.....	70
9.16	LKLA-T actuator air/air Ø85.....	71
9.17	LKLA-T, DN 125-150, ø85 mm (A/A).....	72
9.18	LKLA-T actuator air/spring (NC-NO) Ø133.....	73
9.19	LKLA-T actuator air/air Ø133.....	74

1 Declarations of Conformity

1.1 EU Declaration of Conformity

The designated company

Alfa Laval Kolding A/S, Albuen 31, DK-6000 Kolding, Denmark, +45 79 32 22 00

Company name, address and phone number

Hereby declare that

Valve actuator

Designation

LKLA NC, LKLA NO, LKLA A/A, LKLA-T NO, LKLA-T NC, LKLA-T A/A

Type

is in conformity with the following directives with amendments:

- Machinery Directive 2006/42/EC

The person authorised to compile the technical file is the signer of this document.

Vice President BU Hygienic Fluid Handling
Head of Product Management

Title

Mikkel Nordkvist

Name

Kolding, Denmark

Place

2026-02-01

Date (YYYY-MM-DD)



Signature

DoC Revison_ 01_022026 / This Declaration of Conformity replaces Declaration of Conformity dated 2022-10-01



1.2 UK Declaration of Conformity

The designated company

Alfa Laval Kolding A/S, Albuen 31, DK-6000 Kolding, Denmark, +45 79 32 22 00

Company name, address and phone number

Hereby declare that

Valve actuator

Designation

LKLA NC, LKLA NO, LKLA A/A, LKLA-T NO, LKLA-T NC, LKLA-T A/A

Type

is in conformity with the following directives with amendments:

- The Supply of Machinery (Safety) Regulations 2008

Signed on behalf of: Alfa Laval Kolding A/S.

Vice President BU Hygienic Fluid Handling
Head of Product Management

Title

Mikkel Nordkvist

Name

Kolding, Denmark

Place

2026-02-01

Date (YYYY-MM-DD)



Signature

DoC Revison_ 02_022026



2 Safety

Read this first



This Instruction Manual is designed for operators and service engineers working with the supplied Alfa Laval product.

Operators must read and understand the **Safety, Installation and Operating** instructions of the supplied Alfa Laval product before carrying out any work or before you put the supplied Alfa Laval product into service!

Not following the instructions can result in serious accidents.

This documentation describes the authorized way to use the supplied Alfa Laval product. Alfa Laval will take no responsibility for injury or damage if the equipment is used in any other way.

This Instruction Manual is designed to provide the user with the information to perform tasks safely for all phases in the lifetime of the supplied Alfa Laval product.

The operator shall always read the chapter **Safety** first. Hereafter the operator can skip to the relevant section for the task to be carried out or for the information needed.

Always read the chapter **Technical Data** thoroughly.

This is the complete Instruction Manual for the supplied Alfa Laval product.

NOTE

The illustrations and specifications in this Instruction Manual were effective at the date of printing. However, as continuous improvements are our policy, we reserve the right to alter or modify the Instruction Manual without prior notice or any obligation.

The English version of the Instruction Manual is the original manual. Alfa Laval cannot be held responsible for incorrect translations. In case of doubt, the English version applies.

2.1 Safety Signs

Mandatory Action Signs

	General mandatory action sign.
	Refer to instruction manual.
	Use eye protection - safety glasses.
	Use protective hand wear - safety gloves.
	Wear protective equipment - safety helmet.
	Use ear protection in noisy environments - noise protector.
	Wear protective equipment - safety shoes.

Warning Signs

	<p>General warning.</p>
	<p>Transportation with forklift truck or other industrial vehicles if heavy.</p>
	<p>Hot surface and Burn Hazard.</p>
	<p>Cutting danger.</p>
	<p>Corrosive substance.</p>
	<p>Crushing of hands.</p>
	<p>Danger of injury (lasermarked on the actuator). Do not attempt to disassemble the actuator due to spring under load danger! (The lock wire opening is blocked).</p>
	<p>Danger of injury (lasermarked on the actuator). Do not attempt to cut open actuator due to spring under load danger! (The lock wire opening is blocked).</p>
	<p>Danger of injury (label marked on actuator). Do not attempt to cut the actuator open due to spring under load (the lock wire opening is locked).</p>





2.2 Safety Precautions

All warnings in the Instruction Manual are summarised on these pages. Pay special attention to the instructions below so that severe personal injury and/or damage to the supplied Alfa Laval product is avoided.



General

	<p>To prevent unexpected start and contact with electrical live and moving parts.</p> <p>Always disconnect the power supply and air supply safely:</p> <ul style="list-style-type: none"> • The power supply disconnecting device and air supply must be disconnected (in off position) and locked.
-----------------------------------------------------------------------------------	---------------------------------------------------------------------------------------------------------------------------------------------------------------------------------------------------------------------------------------------------------------------------------------------------------------------------





Transportation and Lifting

  	<p>Never lift or elevate in any way other than described in this manual.</p> <p>Always use the original packaging or similar during transportation.</p> <p>Always ensure that personnel must have experience with lifting operations.</p> <p>Always ensure that all connections are disconnected before attempting to remove the valve from the installation.</p> <p>Always ensure that no leakage of lubricants can occur.</p> <p>Always drain liquid out of the valves before transportation.</p> <p>Always ensure sufficient fixing of the valve during transportation - if specially designed packaging material is available, it must be used.</p> <p>Always ensure that compressed air is released.</p>
 	<p>Always use designated lifting points if defined. Ensure that the lifting equipment is suitable for the supplied Alfa Laval product.</p> <p>Always ensure that the unit is securely fixed during transportation.</p> <p>Always ensure the lifting point to be in line with center of gravity. Adjust lifting point if necessary.</p> <p>Always use suitable transport device ie. forklift or pallet lifter.</p> <p>Always use appropriate lifting equipment for heavy parts when relevant. Use lifting logs when available.</p> <p>Always keep an eye on the load and stay clear during the lifting operation.</p>







Installation

	<p>If the local safety regulations prescribe that the installation has to be inspected and approved by responsible authorities before the valve is put into service, consult with such authorities before installing the equipment and have the projected installation approved by them.</p> <p>Always release compressed air after use.</p> <p>Always assemble the valve completely before startup and make sure everything is in place and correctly tightened.</p>
	<p>Never work on the valve or touch moving parts if the actuator is supplied with compressed air.</p> <p>Always ensure that the valve and pipelines are depressurized, emptied, and cooled down to ambient temperature before installation, inspection, assembly, or dismantling of the valve.</p> <p>Never touch the supplied product or the pipelines when processing hot liquids or sterilizing.</p>
	<p>Do NOT attempt to disassemble or by other means open the actuator due to spring under load danger!</p>

Operation

	<p>Never operate the valve unless a correct installation has been verified.</p> <p>Never dismantle the valve during operation or when pressurized.</p> <p>Necessary precautions must be taken if leakage occurs as this can lead to hazardous situations.</p> <p>Never dismantle or touch the actuator for force opening if supplied with compressed air.</p>
	<p>Never touch the valve or pipelines when hot.</p> <p>Never touch the supplied product or the pipelines when processing hot liquids or sterilizing.</p>
	<p>Always rinse well with clean water after the cleaning.</p> <p>Always handle lye and acid with great care.</p> <p>Always follow the instructions in the safety data sheets from the suppliers of cleaning agents, detergents, oils etc.</p>
	<p>Never touch moving parts during operation.</p> <p>Always release compressed air after use.</p> <p>Never touch the moving parts if the actuator is supplied with compressed air.</p>

Maintenance

	<p>In order to optimise the operation of the supplied Alfa Laval product and to minimize the down time due repair activities, the maintenance includes:</p> <ul style="list-style-type: none"> • Inspection and maintenance of the supplied Alfa Laval product: strictly follow the technical documentation • Preventive maintenance: visual inspection of the supplied Alfa Laval product followed by necessary adjustments and planned periodic replacement of wear and tear parts • Repairs: unscheduled break down of a component, often causing the system to stop. Damaged components must be replaced • Stock of Alfa Laval genuine spare parts: Alfa Laval recommend keeping a stock of genuine spare parts facilitating preventive maintenance and reducing downtime in case of unplanned break downs
 	<p>Always use Alfa Laval genuine spare parts.</p> <p>Always release compressed air after use.</p> <p>Always ensure that the valve and pipelines are depressurized, emptied, and cooled down to ambient temperature before dismantling the valve.</p> <p>Never work on the valve or touch moving parts if the actuator is supplied with compressed air.</p>
   	<p>Do NOT attempt to disassemble or by other means open the actuator due to spring under load danger!</p> <p>Never pressurize the valve/actuator when the valve is serviced unless specifically prescribed.</p> <p>Never service the valve with valve and pipelines under pressure unless specifically prescribed.</p>

Storage

	<p>Alfa Laval recommend:</p> <ul style="list-style-type: none"> • Store the supplied Alfa Laval product as supplied in original packaging • Port opening(s) should be protected against any ingress • Bare steel (not stainless) should be lightly oiled/greased • Store in a clean, dry place without direct sunlight or UV light • Temperature range -5 °C to +40 °C (23 °F - 104 °F) • Relative humidity less than 60% • No exposure to corrosive substances (including contained air)
-------------------------------------------------------------------------------------	-----------------------------------------------------------------------------------------------------------------------------------------------------------------------------------------------------------------------------------------------------------------------------------------------------------------------------------------------------------------------------------------------------------------------------------------------------------------------------------------------------------------------------------------------------------------------

Noise



Under certain operating conditions, the supplied Alfa Laval product and/or the systems in which they are installed can produce high sound pressure levels. Appropriate noise protection measures should be taken when necessary and in accordance with local legislation.

Hazards



Burn Hazard

- Lubrication oil, machine parts and various machine surfaces can be hot and cause burns. Wear protective gloves



Corrosive Hazard

- Always handle cleaning liquids, lye and acid with great care and in accordance with separate instructions for those fluids
- When using chemical cleaning agents and lubricants, make sure you follow the general rules and suppliers recommendation regarding ventilation, personnel protection etc.



Cut Hazard



- Sharp edges, especially on threads, can cause cuts. Wear protective gloves



Crushing Hazard

- Avoid placing hands into valve orifice pinch points

Health Hazard

  	<p>Danger of injury: (an extra yellow label marked on the actuator from June 2016). Do NOT attempt to cut the actuator open due to spring under load. (The lock wire opening is locked).</p> <p>Danger of injury (laser marked on the actuator). Do NOT attempt to disassemble the actuator due to spring under load danger! (The lock wire opening is locked).</p> <p>Danger of injury (label marked on actuator). Do NOT attempt to cut the actuator open due to spring under load. (The lock wire opening is locked).</p>
-------------------------------------------------------------------------------------------------------------------------------------------------------------------------------------------------------------------------------------------------------	---------------------------------------------------------------------------------------------------------------------------------------------------------------------------------------------------------------------------------------------------------------------------------------------------------------------------------------------------------------------------------------------------------------------------------------------------------------------------------------------------------------------------------------------------

Safety check

	<p>A visual inspection of any protective device (shield, guard, cover or other) on the supplied Alfa Laval product shall be carried out at least every 12 months. If the protective device is lost or damaged, especially when this leads to deterioration of safety performance, it shall be replaced. The fixing of the protective device should only be replaced with fixings of the same or an equivalent type.</p> <p>Inspection acceptance criteria:</p> <ul style="list-style-type: none"> • It should not be possible to reach moving parts originally protected by a protective device • The protective device must be securely mounted • Ensure that screws for the protective device are securely tightened <p>Procedure in case of non-acceptance:</p> <ul style="list-style-type: none"> • Fix and/or replace the protective device
-----------------------------------------------------------------------------------	----------------------------------------------------------------------------------------------------------------------------------------------------------------------------------------------------------------------------------------------------------------------------------------------------------------------------------------------------------------------------------------------------------------------------------------------------------------------------------------------------------------------------------------------------------------------------------------------------------------------------------------------------------------------------------------------------------------------------------------------------------------------------------------------------------------------------------------------------------------------------------------------------------------

2.3 Warning Signs in Text

Pay attention to the safety instructions in this Instruction Manual.

Below are definitions of the four grades of warning signs used in the text where there is a risk for injury to personnel or damage to the supplied Alfa Laval product.



Indicates an imminently hazardous situation which, if not avoided, will result in death or serious injury.



Indicates a potentially hazardous situation which, if not avoided, could result in death or serious injury.



Indicates a potentially hazardous situation which, if not avoided, may result in minor or moderate damage to the supplied Alfa Laval product.



Indicates important information to simplify or clarify procedures.

2.4 Requirements of Personnel

Operators

The operators shall read and understand this Instruction Manual.

Maintenance personnel

The maintenance personnel shall read and understand this Instruction Manual. The maintenance personnel or technicians shall be skilled within the field required to carry out the maintenance work safely.

Trainees

Trainees can perform tasks under the supervision of an experienced employee.

People in general

The public shall not have access to the supplied Alfa Laval product.

In some cases, specially skilled personnel may need to be hired (i.e. electricians, welders). In some cases the personnel has to be certified according to local regulations with experience of similar types of work.

2.5 Recycling Information



If the actuator is marked with one of the below warnings, do **NOT** attempt to disassemble it.

The spring inside is under load — any type of breakage or attempt to open the actuator can lead to severe injury or even death!



Unpacking

Packing material may consist of wood, plastics, cardboard boxes and in some cases metal straps.



- Wood and cardboard boxes can be reused, recycled or used for energy recovery
- Plastics should be recycled or burnt at a licensed waste incineration plant
- Metal straps should be sent for material recycling

Maintenance

During maintenance, oil (if used) and wear parts in the supplied Alfa Laval product should be replaced.

- Oil and all non-metal wear parts must be disposed of in accordance with local regulations
- Rubber and plastics should be burnt at a licensed waste incineration plant. If not available they should be disposed of in accordance with local regulations
- Bearings and other metal parts should be sent to a licensed handler for material recycling
- Seal rings and friction linings should be disposed of to a licensed land fill site. Check your local regulations
- All metal parts should be sent for material recycling
- Worn out or defected electronic parts should be sent to a licensed handler for material recycling

Scrapping

At end of use, the equipment must be recycled in accordance with the relevant local regulations. Besides the equipment itself, any hazardous residues from the process liquid must be considered and dealt with in a proper manner. When in doubt, or in the absence of local regulations, please contact your local Alfa Laval sales company.

How to contact Alfa Laval

Contact details for all countries are continually updated on our website.

Please visit www.alfalaval.com to access the information directly.

3 Introduction — LKB/LKB-F

The Alfa Laval LKB Butterfly Valve is a reliable, hygienic in-line valve for routing low and medium-viscosity liquids in stainless steel pipe systems due to its substantial opening area and low flow resistance. The LKB is available with a standard handle with spring-locking action for straightforward manual operation or with a pneumatic actuator for pneumatic operation.

This page is intentionally left blank.

4 Installation

4.1 Unpacking/Delivery

NOTE

The instruction manual is part of the delivery.

Study the instructions carefully.

The items refer to *Parts Lists and Exploded Views* on page 53.

The valve is preassembled before delivery.

CAUTION

Alfa Laval cannot be held responsible for incorrect unpacking.

Check the delivery:

1. Complete valve.
2. Complete actuator, if supplied.
3. Bracket for actuator, if supplied.
4. Complete handle, if supplied.
5. Delivery note.

Standard delivery of valve parts:

1. Two valve body halves (1).
2. Valve disc (2) fitted in seal ring (5).
3. Two bushes (3, 4) fitted on the disc stem.
4. A set of screws and nuts (6).
5. Two flanges (7) and two flange seal rings (8), (LKB-F).

LKB / LKB-2

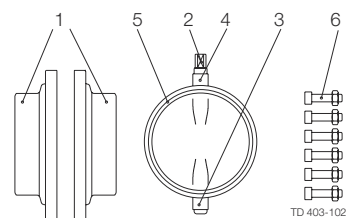

LKB-F (only for welding)

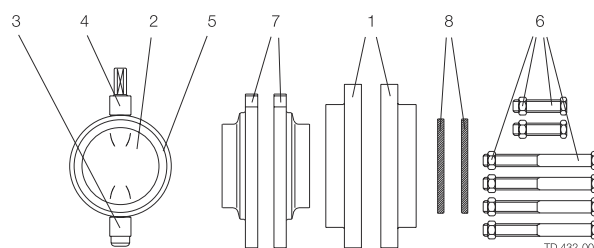

Delivery of actuator and bracket:

1. Complete actuator with coupling and activating ring (Ø85 mm) or indication pin (Ø133 mm).
2. Bracket with screws for the actuator.
3. Water rejector (if not mounted).

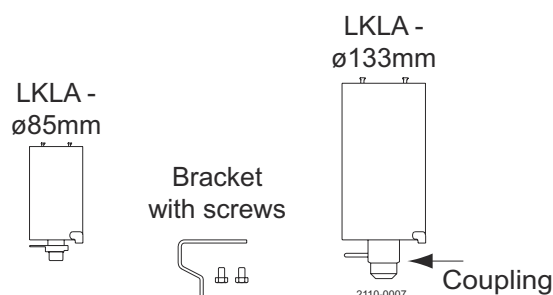

1 Remove packing materials!

- a) Clean the valve/valve parts for possible packing materials.
- b) Clean the handle or the actuator, if supplied.

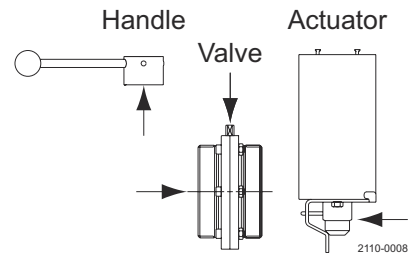
**2 Inspection!**

- a) Inspect the valve/valve parts for visible transport damage.
- b) Inspect the handle or the actuator, if supplied.



Avoid damaging the valve/valve parts.
Avoid damaging the handle or the actuator, if supplied.

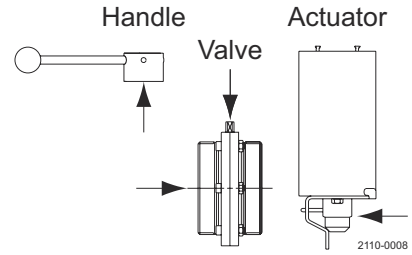

4.2 General installation

NOTE

Study the instructions carefully.

The valve has welding ends as standard but can also be supplied with fittings.

NC = Normally closed.

NO = Normally open.

A/A = Air/air activated.

Always read the *Technical Data* on page 47 thoroughly.

NOTE

For EHEDG approved valves, use connection in compliance with the EHEDG position paper "Easy cleanable Pipe couplings and Process connections.

For EHEDG compliance during cleaning a minimum velocity of 1.5 m/s is required.

CAUTION

Alfa Laval cannot be held responsible for incorrect installation.

WARNING

Always release compressed air after use.

Never touch the coupling between the valve body and the actuator if compressed air is supplied to the actuator.

1 Avoid stressing the valve.

Pay special attention to:

- Vibrations
- Thermal expansion of the tubes
- Excessive welding
- Overloading of the pipelines

Risk of damage!

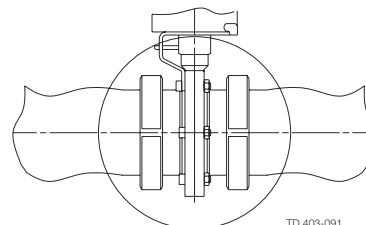

TD 403-091

2 Fittings:

Ensure that the connections are tight.

Remember seal rings!

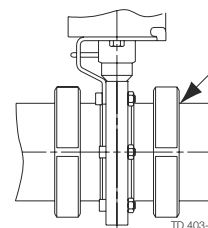

TD 403-092

3 Position of actuator:

Position the water rejector on the actuator correctly. (The actuator can be installed in any position).

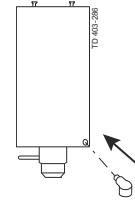

Important!

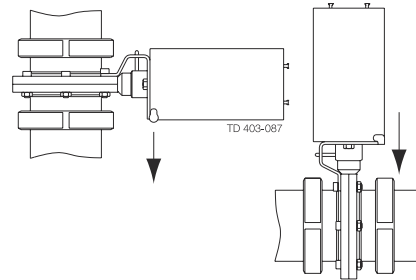

Turn the ventilation opening downwards!

Air connection of actuator:

Connect compressed air correctly.

Pay special attention to the warnings!

Pre-use check:

Open and close the valve several times to ensure that the valve disc moves smoothly against the seal ring.

Pay special attention to the warnings!

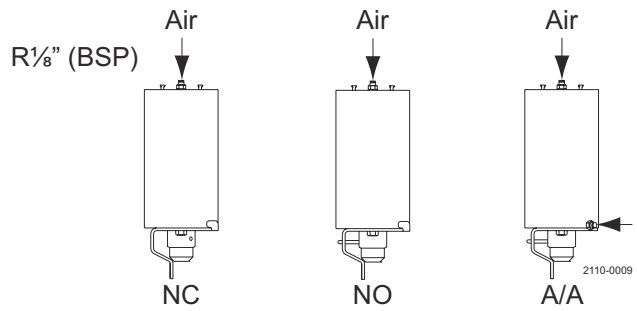

4.3 Welding

! NOTE

Study the instructions carefully.

The valve is supplied as separate parts to facilitate the welding.

LKB: for ISO tubes.

LKB-2: for DIN tubes.

LKB-F: with flange connection.

LKB/LKB-2

1. Weld the valve body halves into the pipelines.
2. Maintain the minimum clearance (A) so that the actuator can be removed.
3. If welding both valve body halves, ensure that they can be moved axially **B1 mm**, so that the valve parts can be removed.
4. After welding assemble the valve in accordance with [Valve assembly — LKB/LKB-2/LKB-LP](#) on page 37.

LKB-F

1. Weld the flanges into the pipelines.
2. Maintain the minimum clearances (A and B2) so that the actuator and the valve parts can be removed.
3. After welding assemble the valve in accordance with [Valve assembly — LKB-F](#) on page 41.

Pre-use check

Open and close the valve several times to ensure that the valve disc moves smoothly against the seal ring.

Pay special attention to the warnings!

LKB/LKB-2

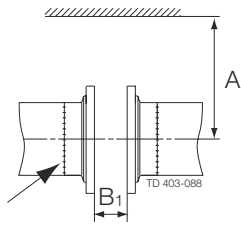

LKB-F

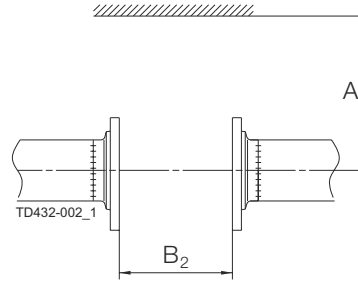

Size	A (mm)				B ₁ (mm)	B ₂ (mm)
	Ø85		Ø133			
	LKLA	LKLA-T	LKLA	LKLA-T		
25 mm / 1"	245				20	43
38 mm / 1½"	245				20	43
51 mm / 2"	255				20	47
63.5 mm / 2½"	265				24	46
76.1 mm / 3"	265				24	59
101.6 mm / 4"	290		420		37	59
DN25	245	172 mm (incl. top unit)		172 mm	20	43
DN32	245			(incl. top unit)	20	43
DN40	250				20	43
DN50	260				20	47
DN65	270				24	59
DN80	275				27	59
DN100	290		420		27	59
DN125	315		440		30	63
DN250	325		445		41	79

4.4 Fitting Actuator/Bracket/Handle on the Valve (Optional Extras)

NOTE

Study the instructions carefully and pay special attention to the warnings!

NC = Normally closed.

NO = Normally open.

A/A = Air/air activated.

Bracket/indication

1. Fit the bracket as shown.
2. Fit and tighten the screws.
3. Fit the activating ring/indication pin as shown.

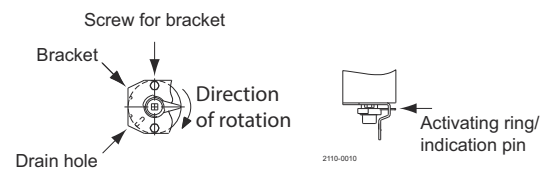

Actuator/bracket - NC

1. Ensure that the valve is closed by checking the position of the groove of the disc stem top.
2. Fit the actuator/bracket in accordance with [Valve Assembly, Step 3](#).

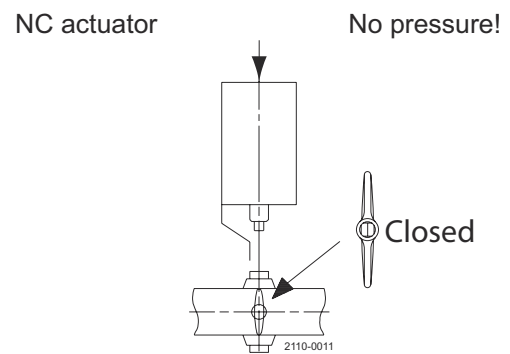

Actuator/bracket - NO

1. Ensure that the valve is open by checking the position of the groove of the disc stem top.
2. Fit the actuator/bracket in accordance with [Valve Assembly, Step 3](#).

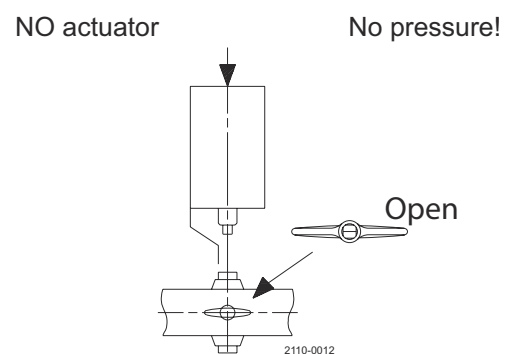

Actuator/bracket - A/A

1. Ensure that the valve is open by checking the position of the groove of the disc stem top.
2. Supply compressed air to the actuator.
3. Fit the actuator/bracket in accordance with [Valve Assembly, Step 3](#).

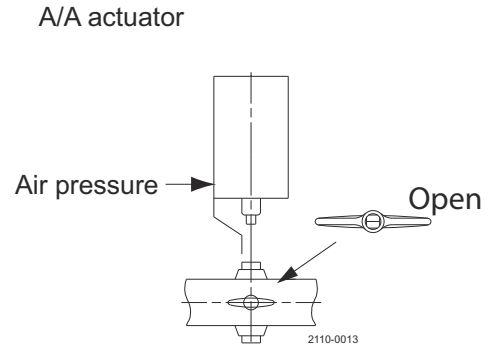

Handle/indication

1. Fit the standard handle on the valve so that the screw can enter the hole in the disc connection.
2. Fit the handle with position indication as shown and in accordance with [Valve Assembly, Step 3](#).

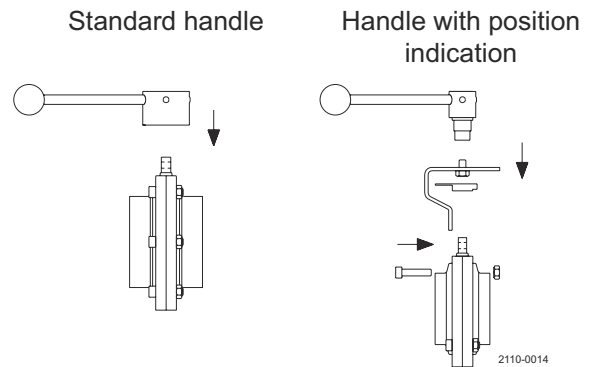

Pre-use check



NOTE

Pay special attention to the warnings!

Open and close the valve several times to ensure that it operates smoothly.

5 Operation

5.1 Operation

NOTE

Study the instructions carefully and pay special attention to the warnings!

The valve is automatically or manually operated by means of an actuator or a handle.

Always read the *Technical Data* on page 47 thoroughly.

CAUTION

Alfa Laval cannot be held responsible for incorrect operation.

DANGER Burning danger

Never touch the supplied product or the pipelines when processing hot liquids or sterilizing..

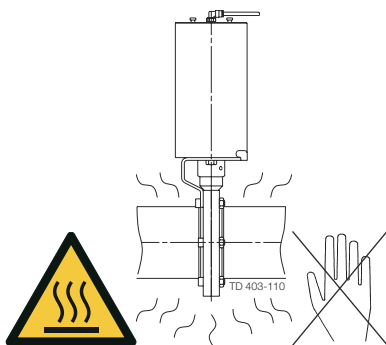

DANGER

Never touch the coupling between the valve body and the actuator if compressed air is supplied to the actuator.

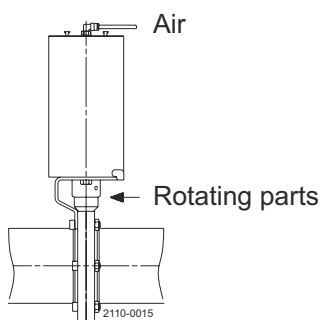

Operation by means of actuator

Automatic on/off operation by means of compressed air.

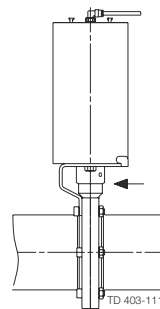

Operation by means of standard handle

1. Manual on/off operation.
2. Pull the handle outwards while rotating it.

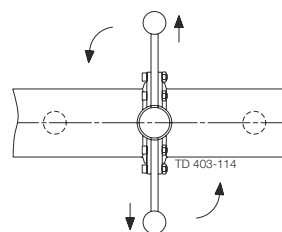

NOTE

This also applies for the Lockable Multiposition Handle.

Operation by means of regulating handle

1. Manual flow regulation because of infinite locking positions.
2. Loosen the handle, rotate it and tighten again.

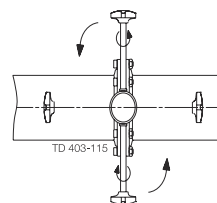

5.2 Troubleshooting

! NOTE

Pay attention to possible break-down.

Study the instructions carefully.

NC = Normally closed.

NO = Normally open.

A/A = Air/air activated.

! NOTE

Study the maintenance instructions carefully before replacing worn parts. - See [General maintenance](#) on page 33.

Problem	Cause/result	Repair
<ul style="list-style-type: none"> External leakage Internal leakage by closed valve (normal wear) 	<ul style="list-style-type: none"> Worn seal ring Worn flange seal ring (LKB-F) 	Replace the seal ring and the bushes
<ul style="list-style-type: none"> External leakage Internal leakage by closed valve (too early) 	<ul style="list-style-type: none"> High pressure High temperature Aggressive liquids Many activations 	<ul style="list-style-type: none"> Change rubber grade Change the operation conditions
<ul style="list-style-type: none"> Difficult to open/close Damage of disc connection (high torque) 	Incorrect seal ring (swelling)	Replace by a seal ring of a different rubber grade
Difficult to open/close	<ul style="list-style-type: none"> 90° displacement of the actuator Incorrect actuator function (NC,NO) Worn actuator bearings Dirt penetration into the actuator 	<ul style="list-style-type: none"> Fit correctly (see Fitting Actuator/Bracket/Handle on the Valve (Optional Extras) on page 27) Change from NC to NO or vice versa Replace the bearings Service the actuator

5.3 Recommended Cleaning

NOTE

The supplied product is designed for cleaning in place (CIP).

NaOH = Caustic soda.

HNO₃ = Nitric acid.

The cleaning agents must be stored/disposed of in accordance with current regulations/directives.

CAUTION

Never touch the supplied product or the pipelines when sterilizing.

Always handle lye and acid with great care.



Examples of cleaning agents

Use clean water free from chlorides

Metric System

1. 1% by weight NaOH at 70°C

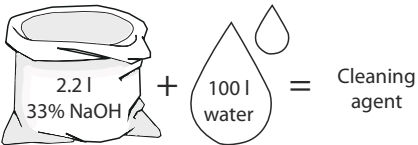
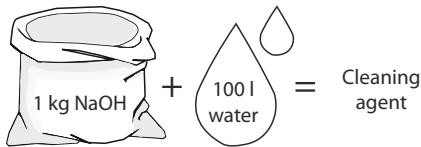

2. 0.5% by weight HNO₃ at 70°C

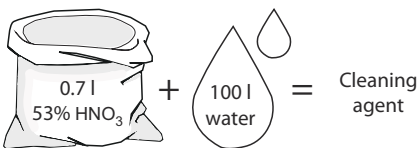

Imperial System

1. 1% by weight NaOH at 158°F

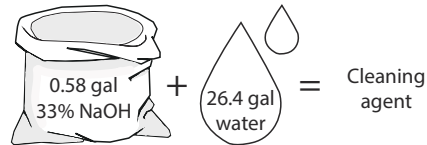
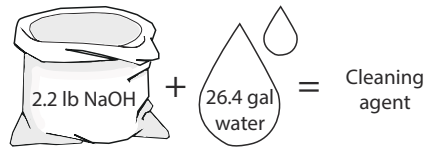

2. 0.5% by weight HNO₃ at 158°F

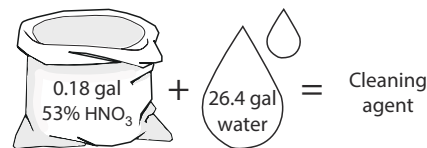

1. Avoid excessive concentration of the cleaning agent ⇒ **Dose gradually!**
2. Adjust the cleaning flow to the process
Milk sterilization/viscous liquids ⇒ Increase the cleaning flow!

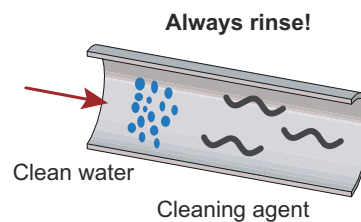

CAUTION

Always rinse well with clean water after the cleaning.

6 Maintenance

6.1 General maintenance

NOTE

Always read the *Technical Data* on page 47 thoroughly.

All scrap must be stored/disposed of in accordance with current regulations and directives.

Study the instructions carefully and pay special attention to the warnings!

Maintain the valve and the regulator carefully.

Always keep spare seal rings, rubber seals, bushes and actuator bearings in stock.

Always use Alfa Laval genuine spare parts.

"Mushrooms" = Fastening connections on the end cap.

CAUTION

Always release compressed air after use.

DANGER Burning danger!

Never service the valve when it is hot.

Never service the valve with valve and pipelines under pressure.

The valve/actuator and the pipelines must **never** be pressurised when servicing the valve/actuator.

Atmospheric pressure required!

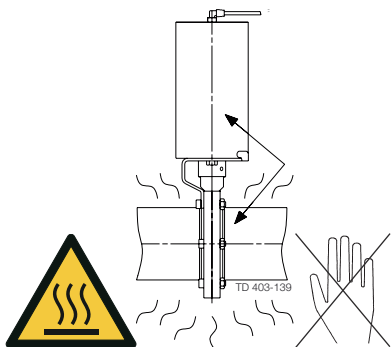

DANGER Crushing danger!

Never stick your fingers through the valve ports if the actuator is supplied with compressed air.

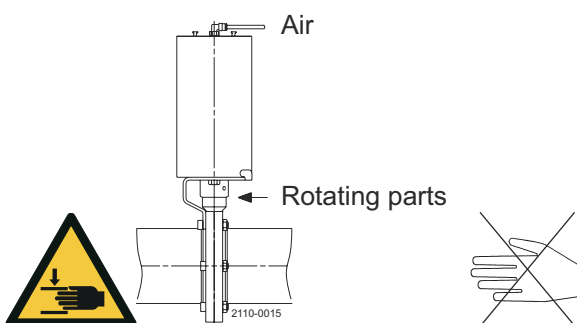

DANGER

Never touch the coupling between the valve body and the actuator if compressed air is supplied to the actuator.

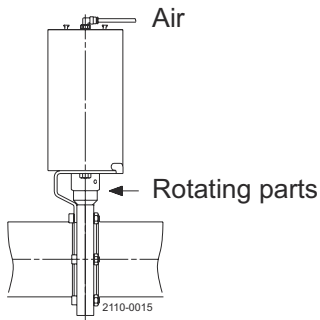

CAUTION

Actuator size Ø85 mm (NC/NO): The actuator springs are **not** caged.

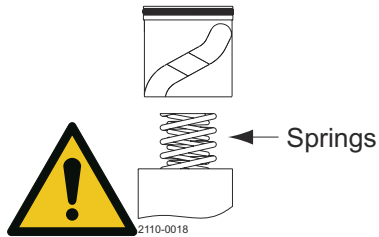

WARNING

End cap of actuator:

Never remove the end cap by using compressed air.

Always fit the end cap with the “mushrooms” turned outwards and position it correctly before supplying compressed air to the actuator.

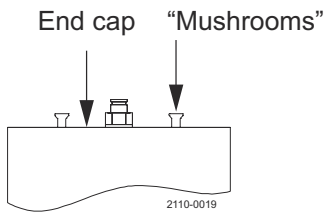

	Valve seal rings	Valve bushes	Actuator rubber seals	Actuator bearings
Preventive maintenance	Replace after 12 months	Replace when replacing the valve seal rings	Replace after 5 years	
Maintenance after leakage (leakage normally starts slowly)	Replace by the end of the day	Replace when replacing the valve seal rings	Replace when possible	
Planned maintenance	<ul style="list-style-type: none"> Regular inspection for leakage and smooth operation Keep a record of the valve Use the statistics for planning of inspections 	Replace when replacing the valve seal rings	<ul style="list-style-type: none"> Regular inspection for leakage and smooth operation Keep a record of the actuator Use the statistics for planning of inspections 	Replace when they become worn
	Replace after leakage		Replace after air leakage	
Lubrication	Before fitting (use US-DA-H1 approved) <ul style="list-style-type: none"> Unisilcon L641(*) Alfa Laval Silicone based Food-grade Lubricant Molycote 111(D) 	None	Before fitting <ul style="list-style-type: none"> Molycote Long term 2 Plus (Δ) Molycote 1132(Δ) (for aggressive environment) 	When replacing actuator rubber seals <ul style="list-style-type: none"> Molycote Long term Plus (Δ) Molycote 1132(Δ) (for aggressive environment)

6.2 Dismantling the valve — LKB/LKB-2/LKB-LP

NOTE

Study the instructions carefully.

The items refer to *Parts Lists and Exploded Views* on page 53.

All scrap must be stored/disposed of in accordance with current regulations and directives.

LKB: for ISO tubes.

LKB-2: for DIN tubes.

1 Valve with actuator:

- a) Remove screws and nuts (6).
- b) Remove the bracket with the actuator.

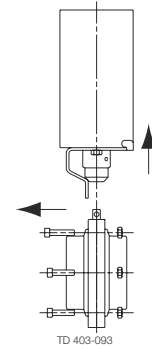

Valve with handle:

- a) Remove the complete handle.
- b) Remove screws and nuts (6).

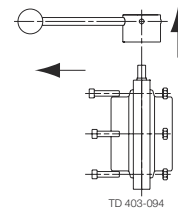

2 Remove seal ring (5) together with valve disc (2).

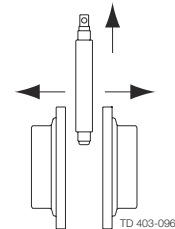

3 Remove bushes (3, 4) from the disc stems.

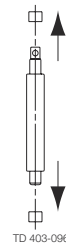

4 Remove valve disc (2) from seal ring (5).

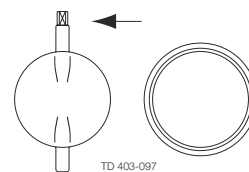

6.3 Valve assembly — LKB/LKB-2/LKB-LP

NOTE

Study the instructions carefully.

The items refer to *Parts Lists and Exploded Views* on page 53.

LKB: for ISO tubes.

LKB-2: for DIN tubes.

Lubricate the seal ring before fitting it.

Lubricate the disc stem before fitting the bushes.

- 1
 - a) Lubricate the pin holes in seal ring (5), (important for Silicone and Viton).
 - b) Fit valve disc (2) in the seal ring (5).

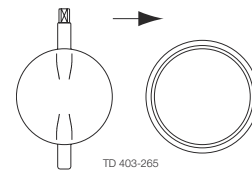

- 2
 - a) Fit bushes (3,4) on the disc stem.
 - b) Fit seal ring (5) together with valve disc (2) between the two valve body halves (1).

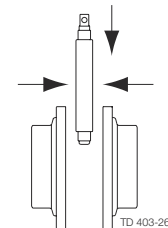

CAUTION

Rotate the valve disc so that the valve is open before tightening screws and nuts (6).

3 Valve with handle:

- a) Fit screws and nuts (6) and torque tighten in accordance with the requirements (see [Table below](#)).
- b) Fit the complete handle on the disc connection and tighten the screw on the handle.

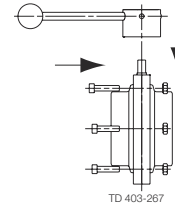

NOTE

This also applies for the Lockable Multiposition Handle.

To avoid seizing the bolts have to be lubricated with Molykote TP-42 Paste or similar Anti-seize lubricant.

Valve with actuator:

- a) Fit the actuator with the bracket so that the disc connection enters the coupling (see [Fitting Actuator/Bracket/Handle on the Valve \(Optional Extras\)](#) on page 27).
- b) Fit screws and nuts (6) and torque tighten in accordance with the requirements so that the bracket is fixed to the valve (see [Table below](#)).

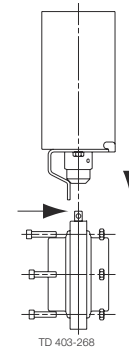

4 Pre-use check:

Check that the valve disc moves smoothly against the seal ring.

Pay special attention to the warnings!

Tools/torque values for assembly of the valve body halves:

Valve size	1"		1½"	2"	2½"	3"	4"		
	25 mm	DN32	38 mm	51 mm	63.5 mm	76 mm	101.6 mm	DN125	DN150
	DN 25		DN40	DN50	DN65	DN80	DN100		
Allen Key	5 mm (0.2")	5 mm (0.2")	5 mm (0.2")	6 mm (0.24")	6 mm (0.24")	6 mm (0.24")	8 mm (0.3")	8 mm (0.3")	8 mm (0.3")
Recommended Torque	18 Nm (13 lbf-ft)	18 Nm (13 lbf-ft)	18 Nm (13 lbf-ft)	20 Nm (15 lbf-ft)	20 Nm (15 lbf-ft)	20 Nm (15 lbf-ft)	38 Nm (38 lbf-ft)	38 Nm (38 lbf-ft)	38 Nm (38 lbf-ft)

6.4 Dismantling the Valve — LKB-F

NOTE

Study the instructions carefully.

The items refer to *Parts Lists and Exploded Views* on page 53.

All scrap must be stored/disposed of in accordance with current regulations and directives.

LKB-F: with flange connection.

- 1
 - a) Loosen the two upper screws and nuts (6).
 - b) Loosen and remove the two lower screws and nuts (6).
 - c) Remove the valve unit from flanges (7).

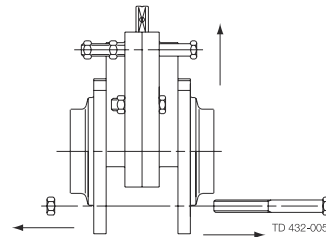

- 2
 - a) Remove the two upper screws and nuts (6), (4 nuts).
 - b) If supplied, remove the actuator from the valve body unit.
 - c) If supplied, loosen the screw and remove the handle from the valve body unit.

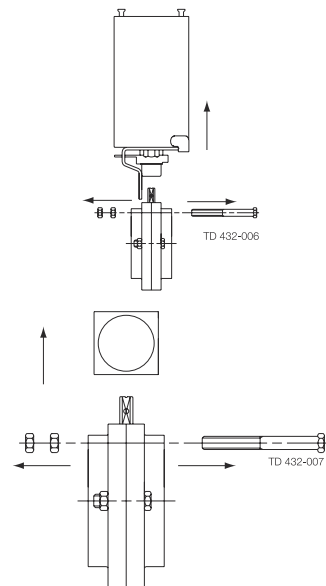

- 3
 - a) Loosen and remove the two centre screws and nuts (6).
 - b) Remove seal ring (5) together with valve disc (2).
 - c) Remove flange seal rings (8).

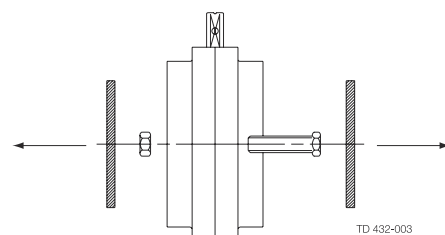

- 4 Remove bushes (3,4) from the disc stems.

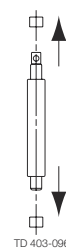

- 5 Remove valve disc (2) from seal ring (5).

! NOTE

For valve sizes 25-38 mm and DN25-40, it is recommended to remove the valve disc by using a special service tool (item no. 9611981090).

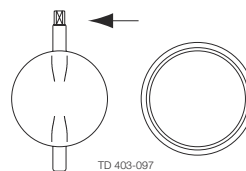

6.5 Valve assembly — LKB-F

NOTE

Study the instructions carefully.

The items refer to *Parts Lists and Exploded Views* on page 53.

LKB-F: with flange connection.

Lubricate the seal ring before fitting it.

Lubricate the disc stem before fitting the bushes.

- 1
 - a) Lubricate the pin holes in seal ring (5), (important for Silicone and Viton).
 - b) Fit valve disc (2) in the seal ring (5).
 - c) Fit bushes (3,4) in the disc stem.

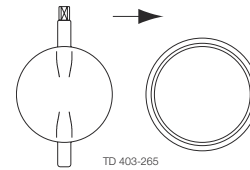

NOTE

For the valve sizes 25-38 mm and DN25-40, it is recommended to fit the valve disc by using a special service tool (item no. 9611981090).

- 2
 - a) Lubricate flange seal rings (8) with water and fit them.
 - b) Fit seal ring (5) together with valve disc (2) between the valve body halves (1).
 - c) Fit and tighten the two centre screws and nuts (6).

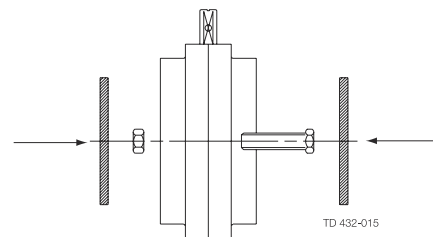

CAUTION

Rotate the valve disc so that the valve is open before tightening screws and nuts (6)

- 3
- a) If supplied, fit the handle and tighten the screw.
 - b) If supplied, fit the actuator.
 - c) Fit the two upper screws and nuts (6), (4 nuts).

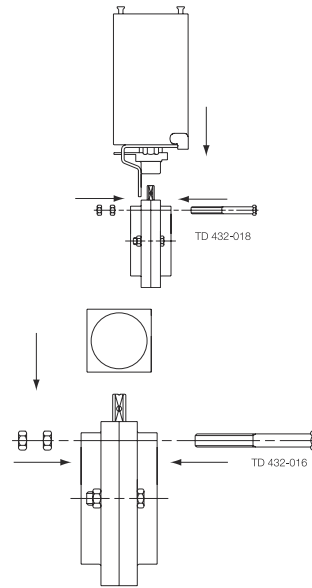

- 4
- a) Fit the valve unit between flanges (7).
 - b) Fit and tighten the two lower screws and nuts (6).
 - c) Tighten the two upper screws and nuts (6).

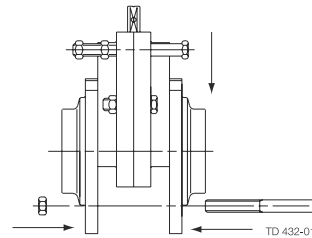

5 **Pre-use check:**

Check that the valve disc moves smoothly against the seal ring.

Pay special attention to the warnings!

Tools/torque values for assembly of the valve body halves:

Valve size	1"		1½"		2"		2½"		3"		4"				
	25 mm	38 mm	51 mm	63.5 mm	76 mm	101.6 mm	DN25	DN32	DN40	DN50	DN65	DN80	DN100	DN125	DN150
Spanner flats	10 mm (0.4")	10 mm (0.4")	10 mm (0.4")	13 mm (0.5")	13 mm (0.5")	13 mm (0.5")	17 mm (0.67")	17 mm (0.67")	17 mm (0.67")	17 mm (0.67")	17 mm (0.67")	17 mm (0.67")	17 mm (0.67")	17 mm (0.67")	17 mm (0.67")
Recommended Torque	18 Nm (13 lbf-ft)	18 Nm (13 lbf-ft)	18 Nm (13 lbf-ft)	20 Nm (15 lbf-ft)	20 Nm (15 lbf-ft)	20 Nm (15 lbf-ft)	38 Nm (38 lbf-ft)	38 Nm (38 lbf-ft)	38 Nm (38 lbf-ft)	38 Nm (38 lbf-ft)	38 Nm (38 lbf-ft)	38 Nm (38 lbf-ft)	38 Nm (38 lbf-ft)	38 Nm (38 lbf-ft)	38 Nm (38 lbf-ft)

6.6 Dismantling of Actuator

NOTE

Study the instructions carefully.

The items refer to *Parts Lists and Exploded Views* on page 53.

All scrap must be stored/disposed of in accordance with current regulations and directives.

NC = Normally closed.

NO = Normally open.

A/A = Air/air activated.

- 1
 - a) Press end cap (5) into air cylinder (1).
 - b) Remove retaining ring (6).

Use a press or special tool (item no. 9611416791).

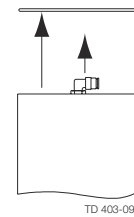

- 2 **NC/NO actuator:**

Release the pressure on end cap (5) carefully and remove the end cap.

Pay special attention to the warning!

A/A actuator:

Remove end cap (5) by hand.

Pay special attention to the warning!

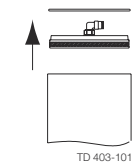
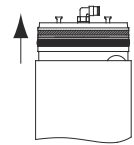

- 3 Remove piston (3) and the springs.

NOTE

- The actuator size $\varnothing 133$ mm has a caged spring assembly.
- The air/air actuator has no springs.

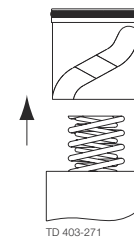

- 4 Remove connex pin (16) and coupling (17) from rotating cylinder stem (2).

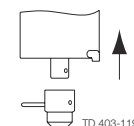

- 5 Remove rotating cylinder (2) and the remaining internal parts from air cylinder (1).

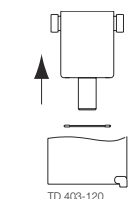

6.7 Assembly of Actuator

NOTE

Study the instructions carefully.

NC = Normally closed.

NO = Normally open.

A/A = Air/air activated.

Lubricate the rubber seals before fitting them.

Lubricate the bearings.

Clean the piston before assembly.

- 1 Fit rotating cylinder (2) in air cylinder (1).

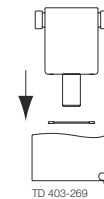

- 2 Fit coupling (17) on rotating cylinder stem (2) and fit connex pin (16).

Fit the connex pin correctly!

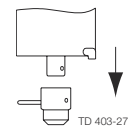

- 3 Fit the springs in rotating cylinder (2) and fit piston (3) carefully.

CAUTION

Fit the piston correctly in relation to the bearings.

NOTE

The air/air actuator has no springs.

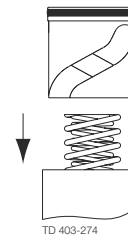

4 A/A actuator:

a) Fit end cap (5) sufficiently into air cylinder (1) so that retaining ring (6) can be fitted in the air cylinder.

b) Position the end cap correctly by hand.

Pay special attention to the warning!

NC/NO actuator:

a) Fit end cap (5) in air cylinder (1) and press sufficiently down so that retaining ring (6) can be fitted in the air cylinder.

b) Release the pressure on the end cap.

Pay special attention to the warning!

Use a press or special tool (item no. 9611416791).

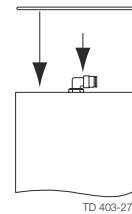
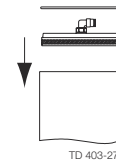
**5 Pre-use check:**

a) Supply compressed air to the actuator.

b) Activate the actuator several times to ensure that it operates smoothly.

Pay special attention to the warnings!

This page is intentionally left blank.

7 Technical Data

NOTE

Technical data must be observed during installation, operation and maintenance.
All personnel should be informed about the technical data.

7.1 Technical Data

Valve		
Max. product pressure:	1000 kPa / 145 psi (10 bar)	
Min. product pressure:	Full vacuum	
Temperature range:	-10 °C to + 140 °C / 14 °F to 284 °F (EPDM) However max. 95 °C / 203 °F when operating the valve (All seals)	
Actuator		
Max. air pressure:	600 kPa / 87 psi (6 bar)	
Min. air pressure, NC and NO:	400 kPa / 60 psi (4 bar)	
Temperature range:	-25 °C to +90 °C / 15 °F to 195 °F	
Air consumption (litres free air):	Ø85 mm / Ø3.35"	0.24 x p (bar)
	Ø133 mm / Ø5.24"	0.95 x p (bar)
Weight:	Ø85 mm / Ø3.35"	3 kg / 6.6 lbs
	Ø133 mm / Ø5.24"	12 kg / 26.4 lbs
ATEX		
Classification:	II 2 G D ¹	

¹ This equipment is outside the scope of the directive 2014/34/EU and must not carry a separate CE marking according to the directive as the equipment has no own ignition source

7.2 Physical Data — LKB/LKB-F

Valve bodies	
Product wetted steel parts:	1.4307 (304L) or 1.4404 (316L)
Disc:	1.4301 (304) or 1.4404 (316L)
Other steel parts:	1.4301 (304)
Rubber grades:	Q, EPDM, FPM, HNBR ¹ or PFA ^{2,3}
Bushes for valve disc:	PVDF
Finish:	Semi-bright
Inside surface finish:	≤ Ra 0.8 μm / ≤ Ra 32μin
Product acc. to PED 97/23/EC	Fluids group 2

¹ LKB-F (DIN) with HNBR and LKB-F (DIN & ISO) with PFA are supplied with EPDM flange seal.

² LKB-F (DIN) with HNBR and LKB-F (DIN & ISO) with PFA are supplied with EPDM flange seal.

³ PFA not FDA compliant.

Actuator	
Actuator body:	1.4307 (304L)
Piston:	Light alloy Air/air version (for Ø85 mm / Ø3.35": Bronze)
Seals:	NBR
Housing for switches:	PPO
Finish	Semi bright

7.3 Weight

(kg)

Size	25 mm	38 mm	51 mm	63.5 mm	76.1 mm	101.6 mm
LKB-F with welding ends and handle	1.6	1.3	2.1	2.9	5.0	7.9
LKB/LKB-2 with welding ends and handle	1.2	1.0	1.5	2.1	3.0	4.7
LKB-F with welding ends and LKLA/LKLA-T ø85	4.3	4.0	4.8	5.6	7.6	19.5
LKB/LKB-2 with welding ends and LKLA/LKLA-T ø133	3.9	3.7	4.2	4.8	5.6	16.3

Size	DN25	DN32	DN40	DN50	DN65	DN80	DN100	DN125	DN150
LKB-F with welding ends and handle	1.6	1.6	1.7	2.6	4.7	5.8	7.9	11.7	12.3
LKB/LKB-2 with welding ends and handle	1.2	1.1	1.3	1.8	3.0	3.5	5.1	7.5	9.0
LKB-F with welding ends and LKLA/LKLA-T ø85	4.3	4.3	4.4	5.3	7.3	8.4	19.5	23.3	23.9
LKB/LKB-2 with welding ends and LKLA/LKLA-T ø133	3.8	3.8	4.0	4.5	5.6	6.1	16.7	19.1	20.6

(lb)

Size	1"	1½"	2"	2½"	3"	4"
LKB-F with welding ends and handle	3.5	2.9	3.3	6.4	11.0	17.4
LKB/LKB-2 with welding ends and handle	2.6	2.2	3.3	4.6	6.6	10.4
LKB-F with welding ends and LKLA/LKLA-T ø85	9.5	8.8	10.6	12.3	16.8	43
LKB/LKB-2 with welding ends and LKLA/LKLA-T ø133	8.6	8.2	9.3	10.6	12.3	29.3

7.4 Noise



One metre / 3 ft away from and 1.6 metres / 5 ft above the exhaust, the noise level of a valve actuator will be approximately 77 dB(A) without noise damper and approximately 72 dB(A) with damper - measured at 7 bar air-pressure.

This page is intentionally left blank.

8 Spare Parts

For every delivered Alfa Laval Product, a spare part list is available.

This spare part list contains a range of the most common wear parts for the machinery. If any component not mentioned is required, please contact your local Alfa Laval representative for availability.

You can find our spare part catalogue at <https://hygienicfluidhandling-catalogue.alfalaval.com>.

Always use Alfa Laval genuine spare parts. The warranty of Alfa Laval products is dependent on use of Alfa Laval genuine spare parts.

8.1 Ordering Spare Parts

When ordering spare parts, please always state:

1. Serial number (if available)
2. Item number/spare part number (if available)
3. Capacity or other relevant identification

8.2 Alfa Laval Service

Alfa Laval is represented in all larger countries of the world.

Do not hesitate to contact your local Alfa Laval representative, with any questions or requirement of spare parts for Alfa Laval equipment.

8.3 Warranty - Definition



The rules of Intended use are absolute. Use of the supplied Alfa Laval product is allowed only when in compliance with the technical data supplied with the Intended use.

Differing utilisation, other than agreed with Alfa Laval Kolding A/S, exclude any liability and warranty.

No modification or alteration of the supplied Alfa Laval product is allowed, unless explicit permission is granted by Alfa Laval Kolding A/S.



Liability and warranty are excluded:

- If advice and instruction of operating instructions are ignored
- For incorrect operation or for insufficient maintenance of the supplied Alfa Laval product
- For any kind of change of function of the supplied Alfa Laval product without prior written agreement by Alfa Laval Kolding A/S
- If supplied Alfa Laval product is modified by non-authorized persons
- If using the supplied Alfa Laval product without attention of appropriate safety regulations, (see [Safety](#) on page 7)
- If protection equipment is not used and vessel process / ancillary equipment is not brought to a standstill
- If the supplied Alfa Laval product and ancillary parts are not properly maintained (to be executed in intervals and including fitting of prescribed replacement parts)

When exchanging parts, only original replacement parts, released from the manufacturer, must be used.

9 Parts Lists and Exploded Views

9.1 Drawings

LKB/LKB-2

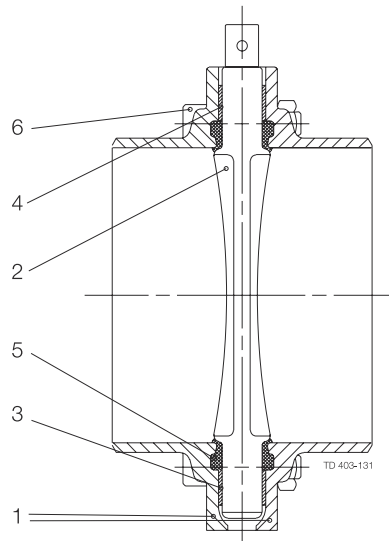

LKB-F

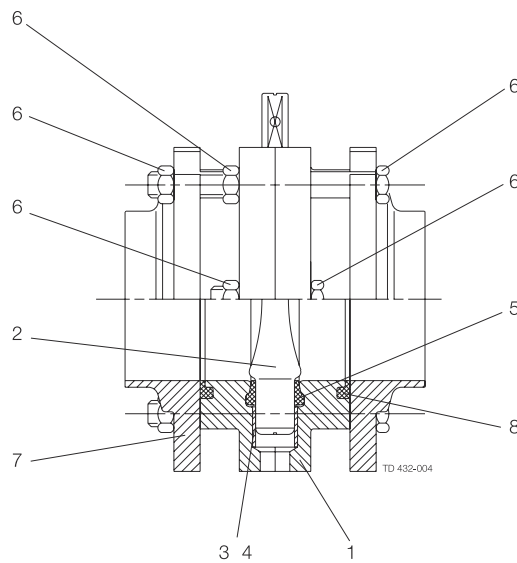

LKB-LP

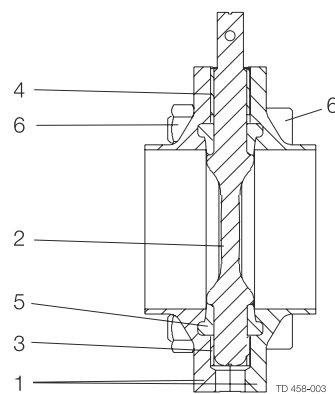

LKLA and LKLA-T actuators Ø85 mm

LKLA-T (NC-NO)

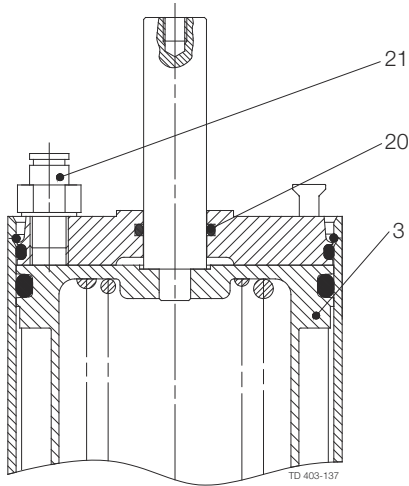

LKLA-T (A/A)

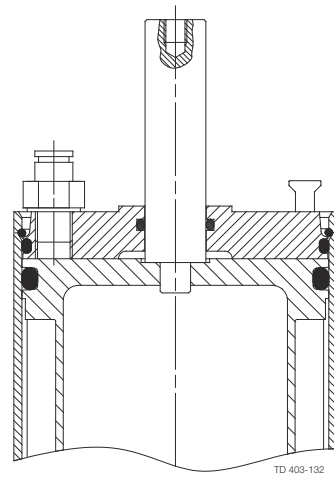

LKLA (NC-NO)

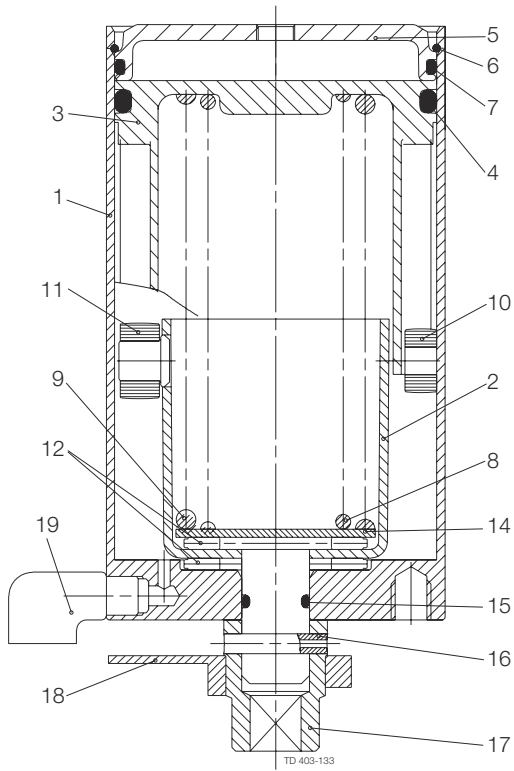

LKLA (A/A)

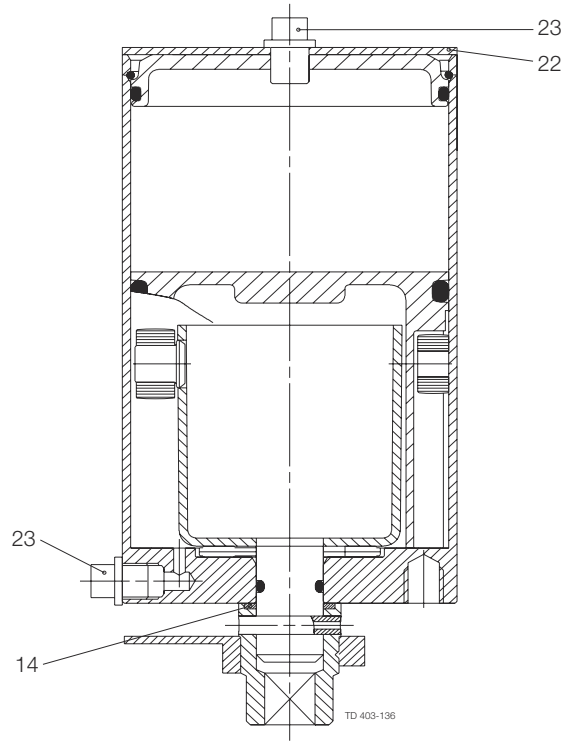

DN 125-150 (A/A)

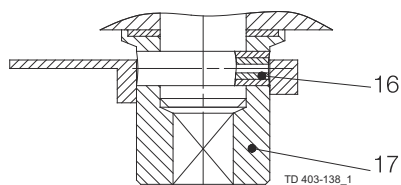

LKLA and LKLA-T actuators Ø133 mm

LKLA-T (NC-NO)

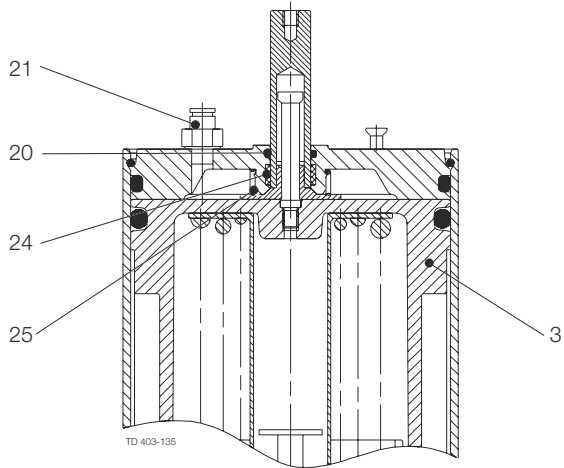

LKLA-T (A/A)

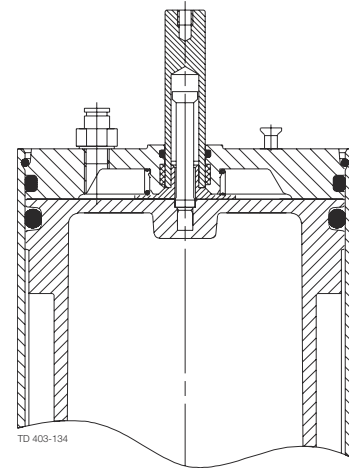

LKLA (NC-NO)

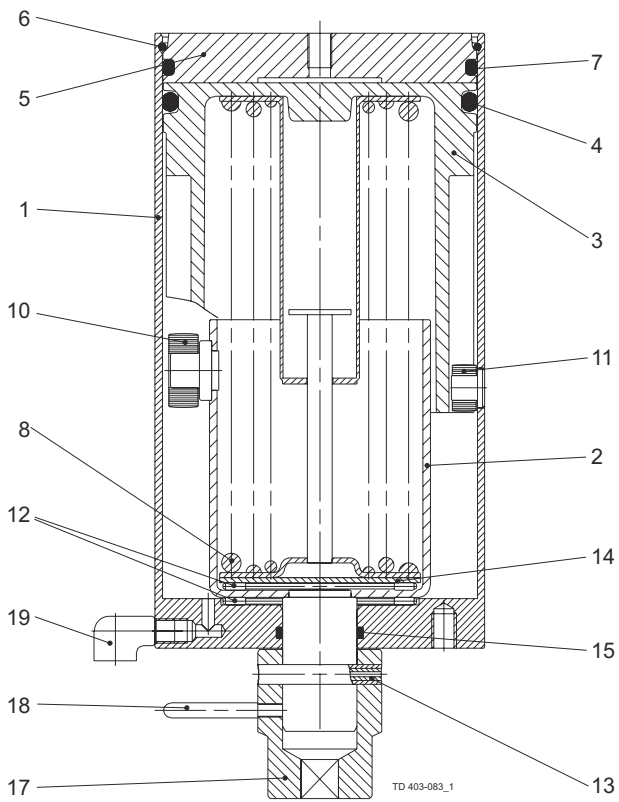

LKLA (A/A)

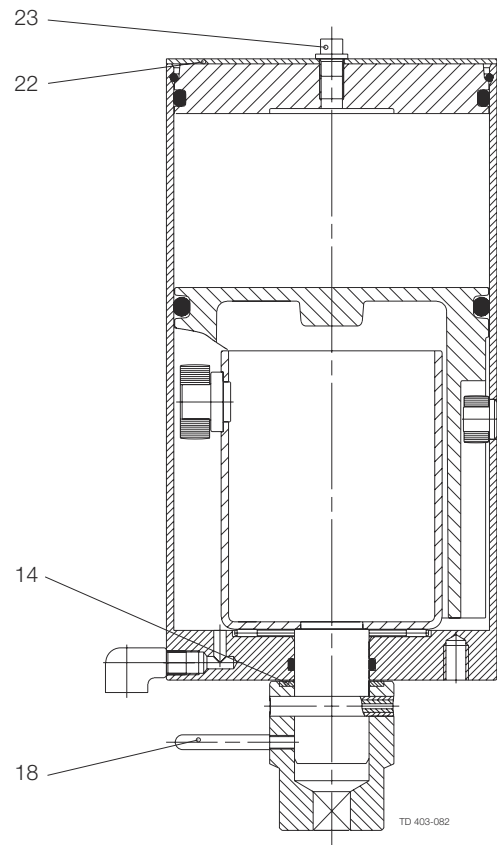

9.2 LKB Butterfly Valve, ISO

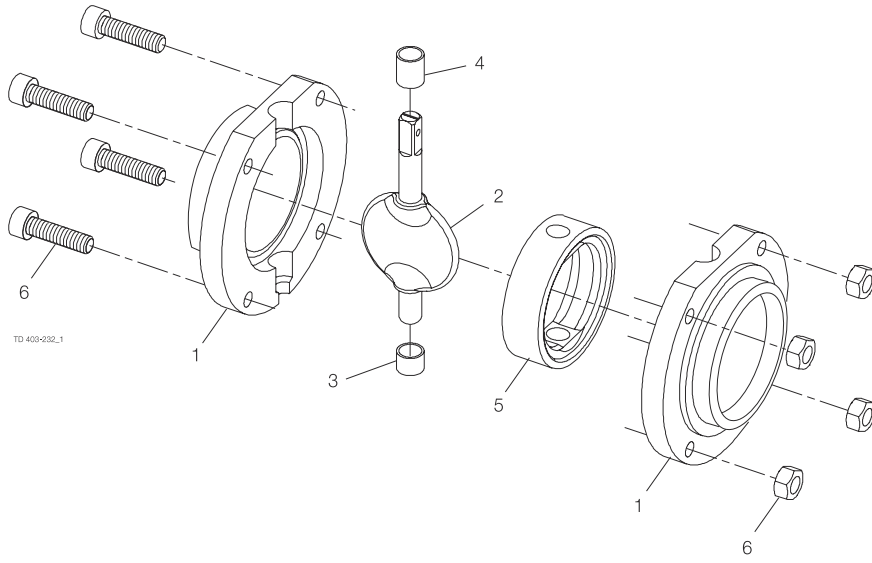

Pos.	Qty.	Denomination
1	2	Valve body half
2	1	Disc
3	1	Bush

Pos.	Qty.	Denomination
4	1	Bush
5	1	Seal ring
6	1	Set of screws

9.3 LKB-F Butterfly Valve, ISO

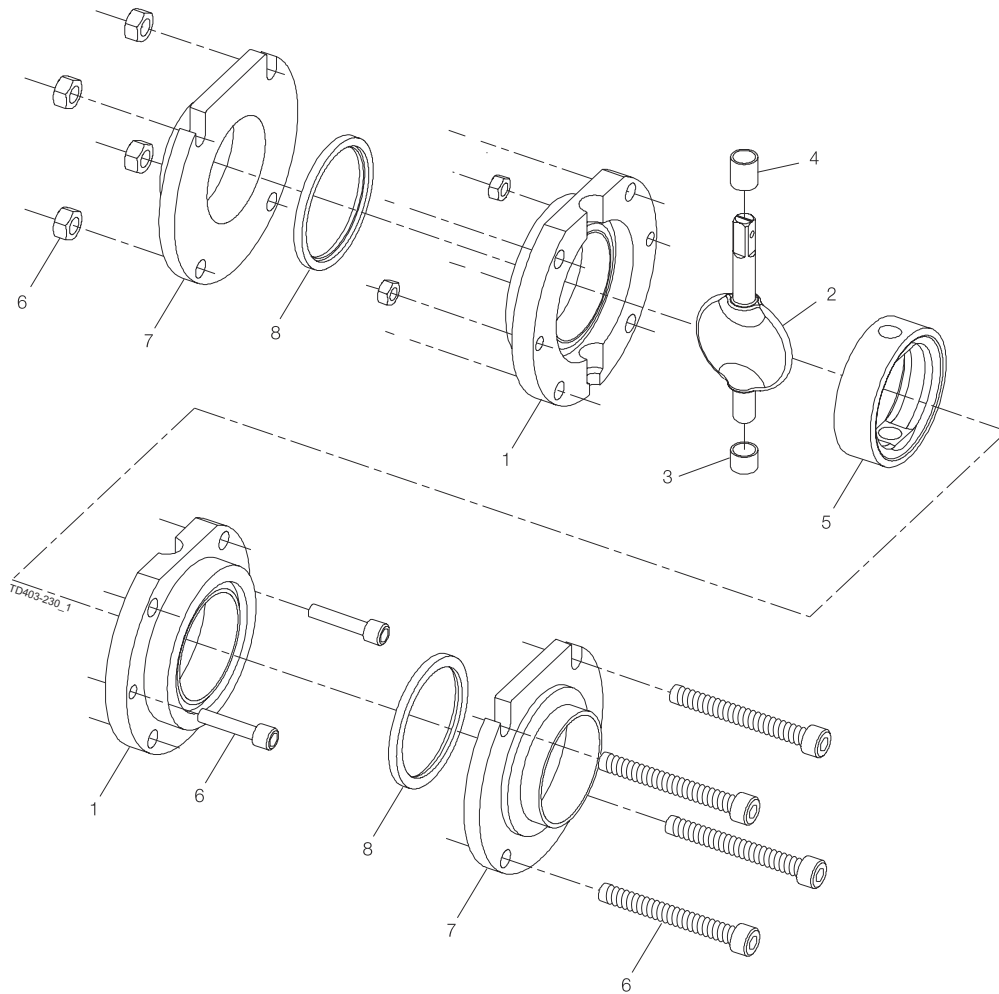

Pos.	Qty.	Denomination
1	2	Valve body half
2	1	Disc
3	1	Bush
4	1	Bush

Pos.	Qty.	Denomination
5	1	Seal ring
6	1	Set of screws
7	2	Flange
8	2	Seal ring

9.4 LKB-F Butterfly Valve, DIN

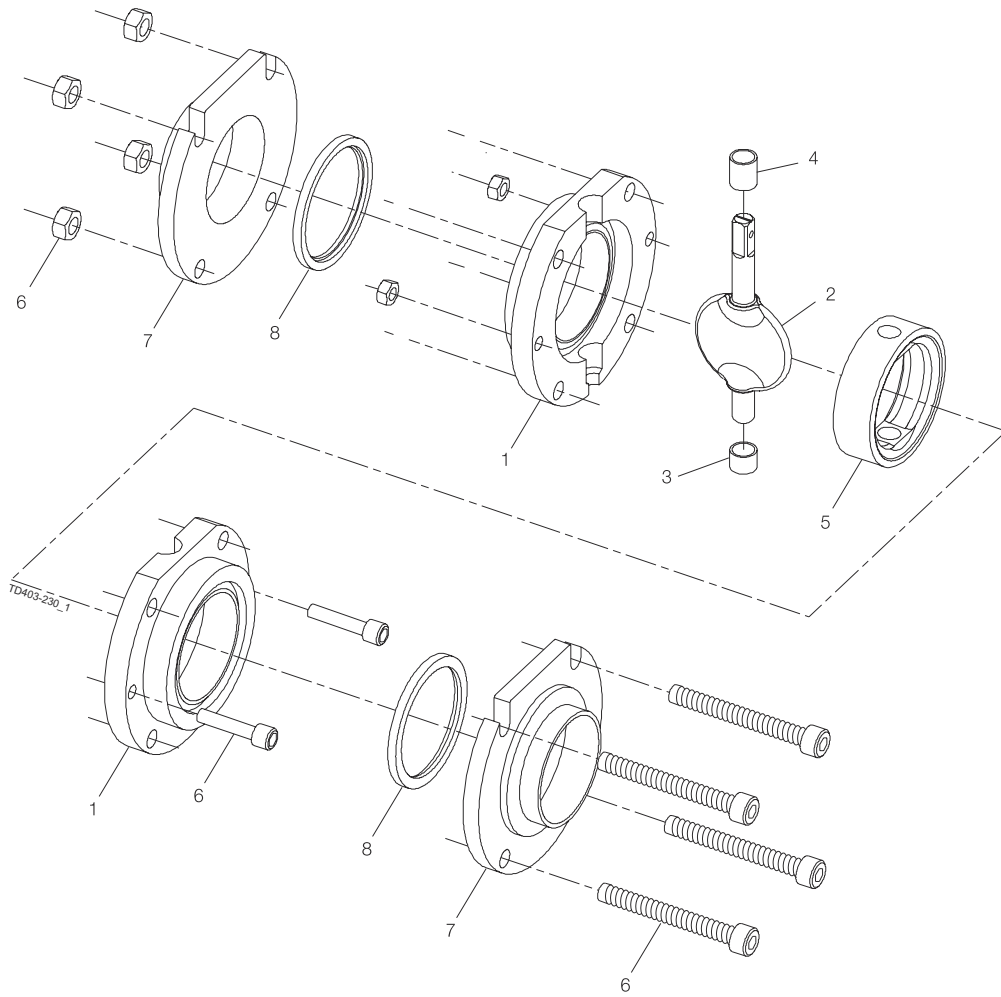

Pos.	Qty.	Denomination
1	2	Valve body half
2	1	Disc
3	1	Bush
4	1	Bush

Pos.	Qty.	Denomination
5	1	Seal ring
6	1	Set of screws
7	2	Flange
8	2	Seal ring

9.5 LKB-2 Butterfly Valve

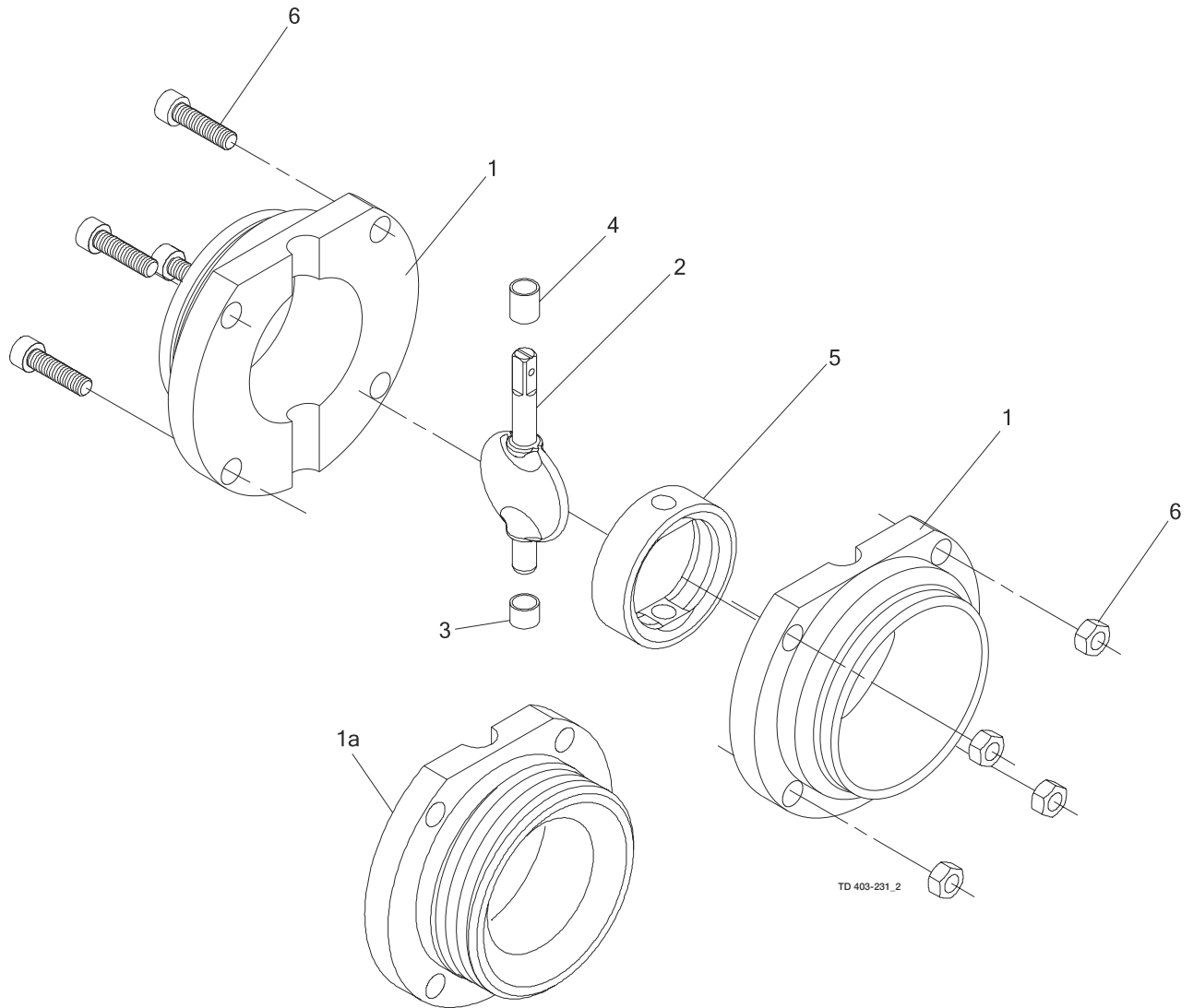

Pos.	Qty.	Denomination
1	2	Valve body half
2	1	Disc
3	1	Bush

Pos.	Qty.	Denomination
4	1	Bush
5	1	Seal ring
6	1	Set of screws

9.6 LKB-LP Butterfly Valve

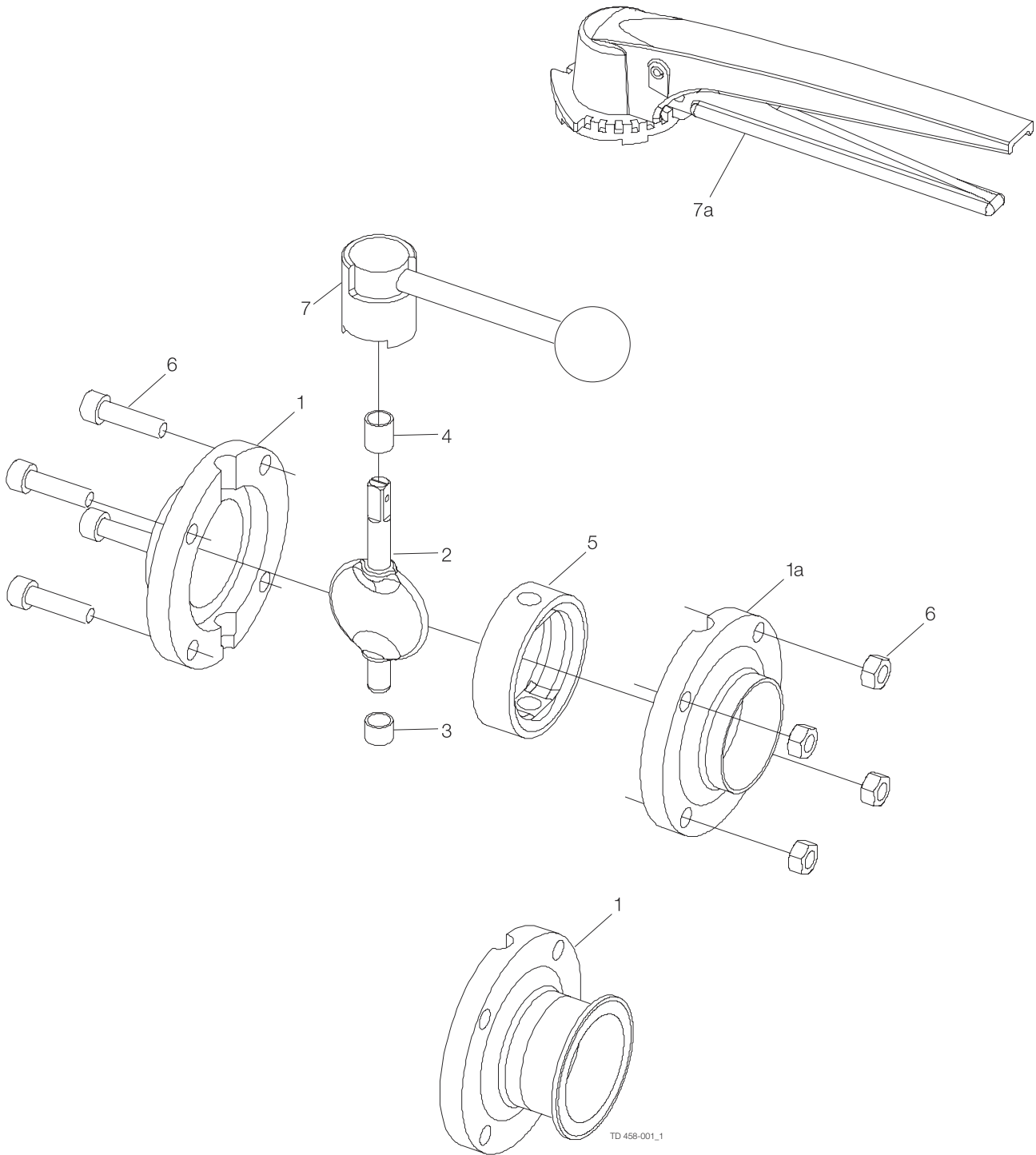

Pos.	Qty.	Denomination
1	2	Valve body half
2	1	Disc
3	1	Bush
4	1	Bush

Pos.	Qty.	Denomination
5	1	Seal ring
6	1	Set of screws
7	1	Handle
7a	1	Lockable multiposition handle (only ISO)

9.7 LKB lockable multiposition handle for valve

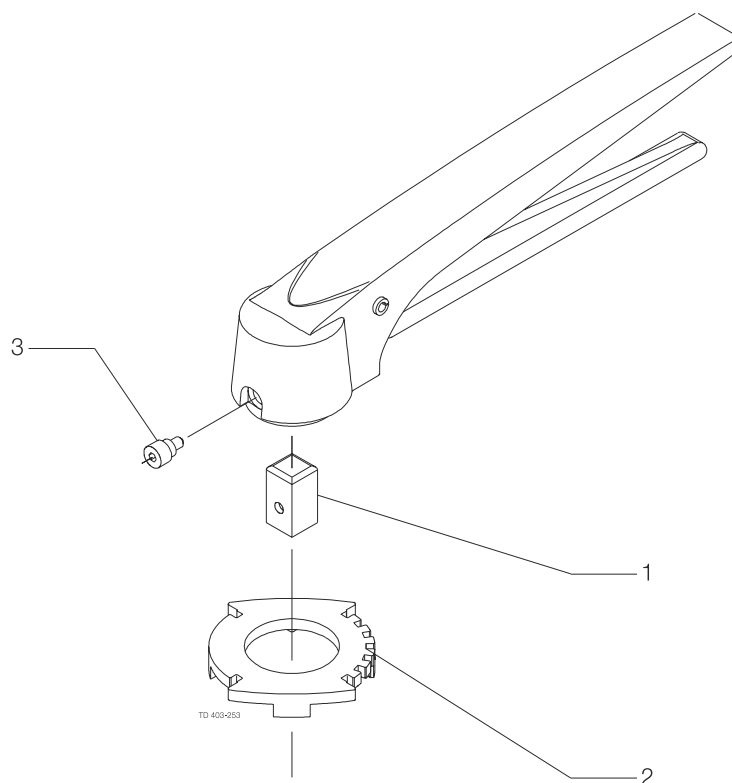

Pos.	Qty.	Denomination
1	1	Insert
2	1	Positioning cap
3	1	Screw

9.8 LKB handle 1.1 for Butterfly Valve

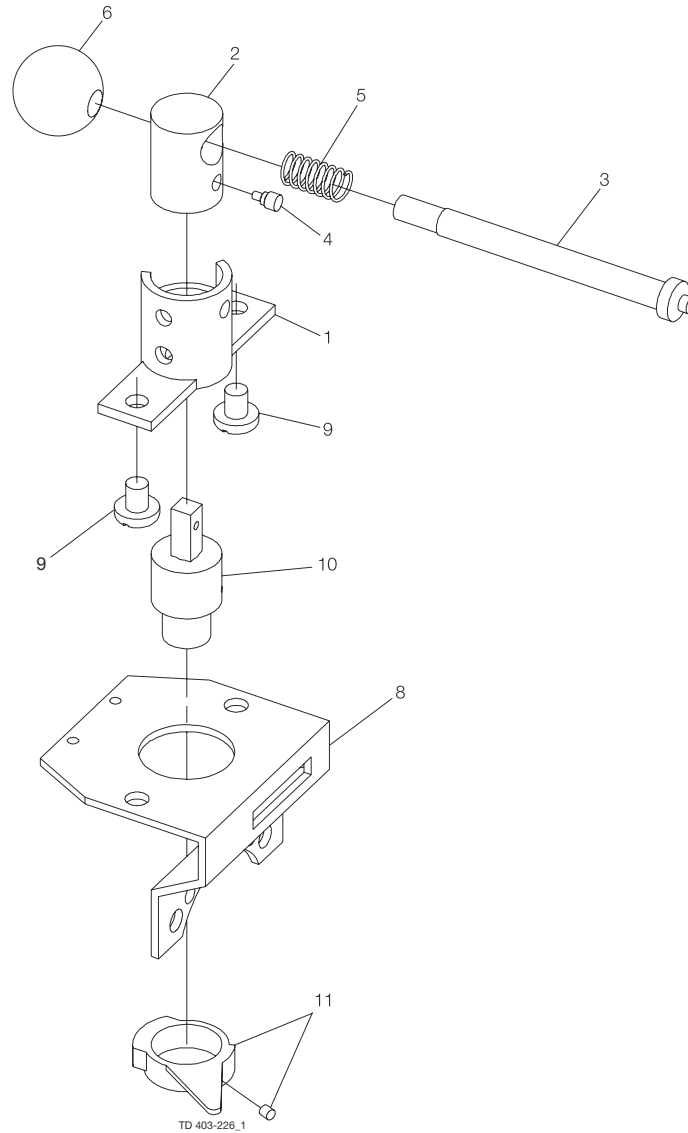

Pos.	Qty.	Denomination
1	1	Location cap with 2 pos.
2	1	Transfer block
3	1	Handle
4	1	Screw with pin
5	1	Spring

Pos.	Qty.	Denomination
6	1	Ball
8	1	Bracket
9	2	Screw
10	1	Coupling
11	1	Activating ring with screw

9.9 Handle 1.1 for indication unit

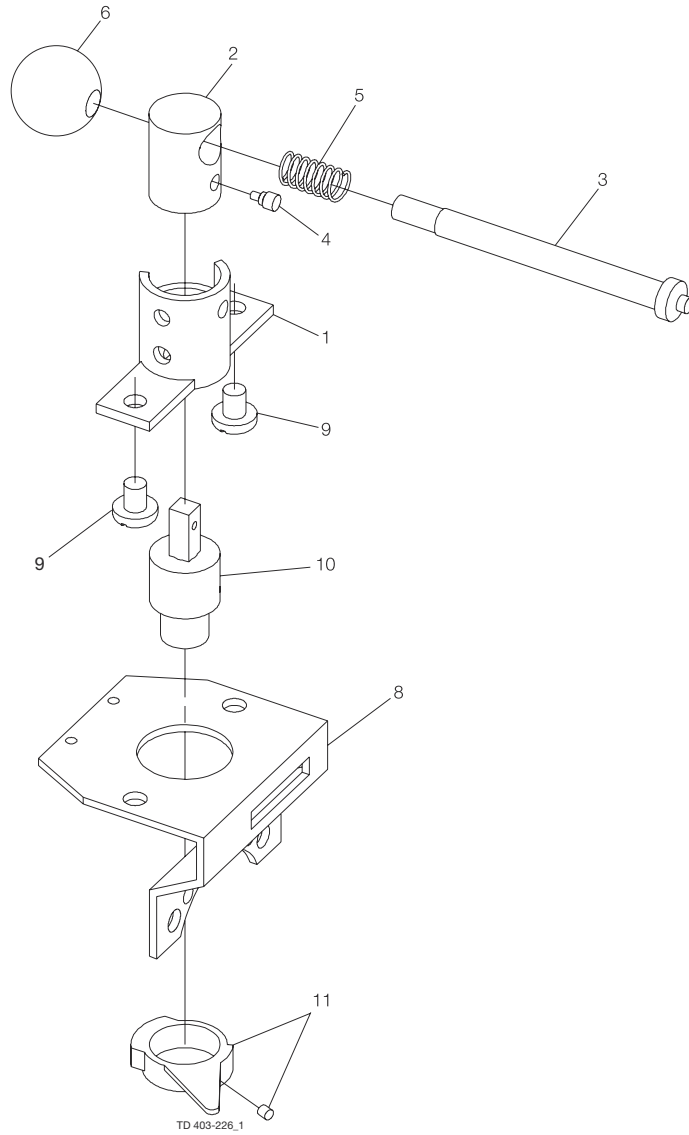

Pos.	Qty.	Denomination
1	1	Location cap with 2 pos.
2	1	Transfer block
3	1	Handle
4	1	Screw with pin
5	1	Spring

Pos.	Qty.	Denomination
6	1	Ball
8	1	Bracket
9	2	Screw
10	1	Coupling
11	1	Activating ring with screw

9.10 LKLA actuator air/spring (NC-NO) Ø85

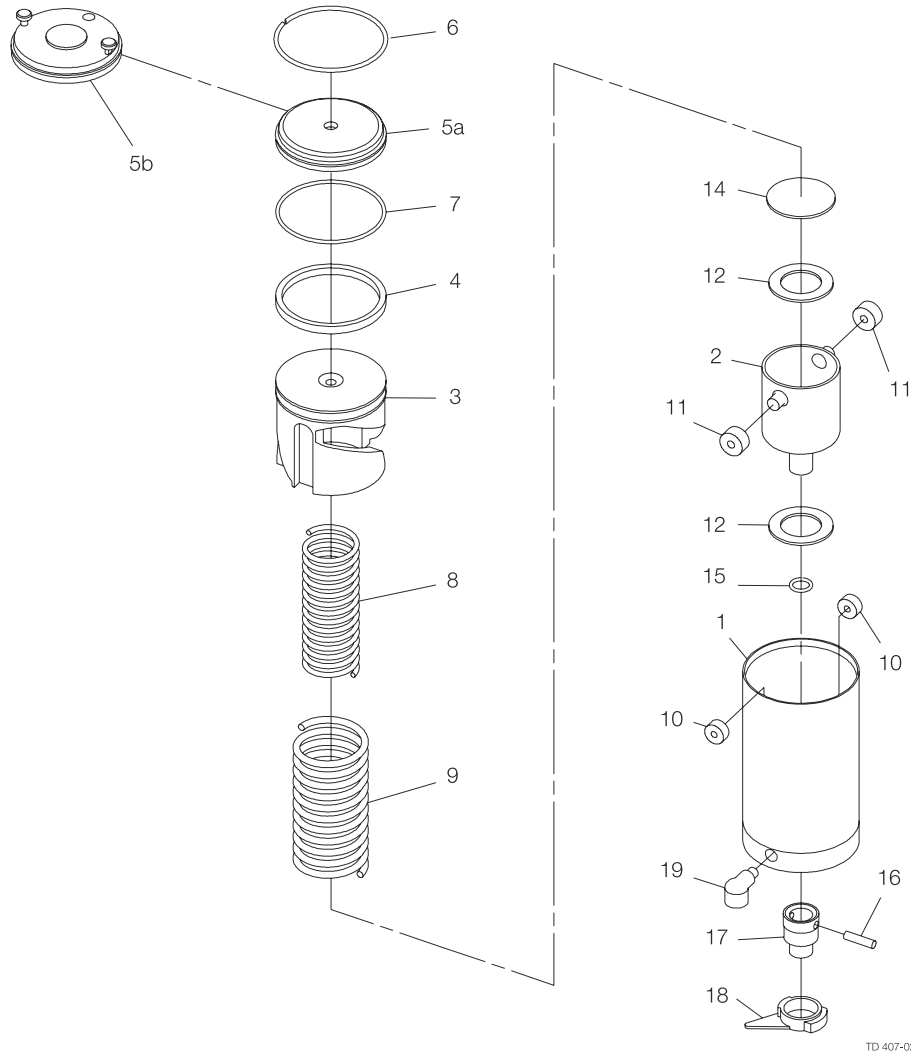

Pos.	Qty.	Denomination
1	1	Air cylinder
2	1	Rotating cylinder
3	1	Piston
4	1	O-ring
5a	1	End cap
5b	1	End cap, Mark III
6	1	Retaining ring
7	1	O-ring
8	1	Inner spring
9	1	Outer spring

Pos.	Qty.	Denomination
10	2	Needle bearing
11	2	Needle bearing
12	2	Thrust bearing
14	1	Thrust plate
15	1	O-ring
16	1	Connex pin
17	1	Coupling
18	1	Activating ring, Noryl with screw
19	1	Water rejector (period 8310-)

9.11 LKLA actuator air/air Ø85

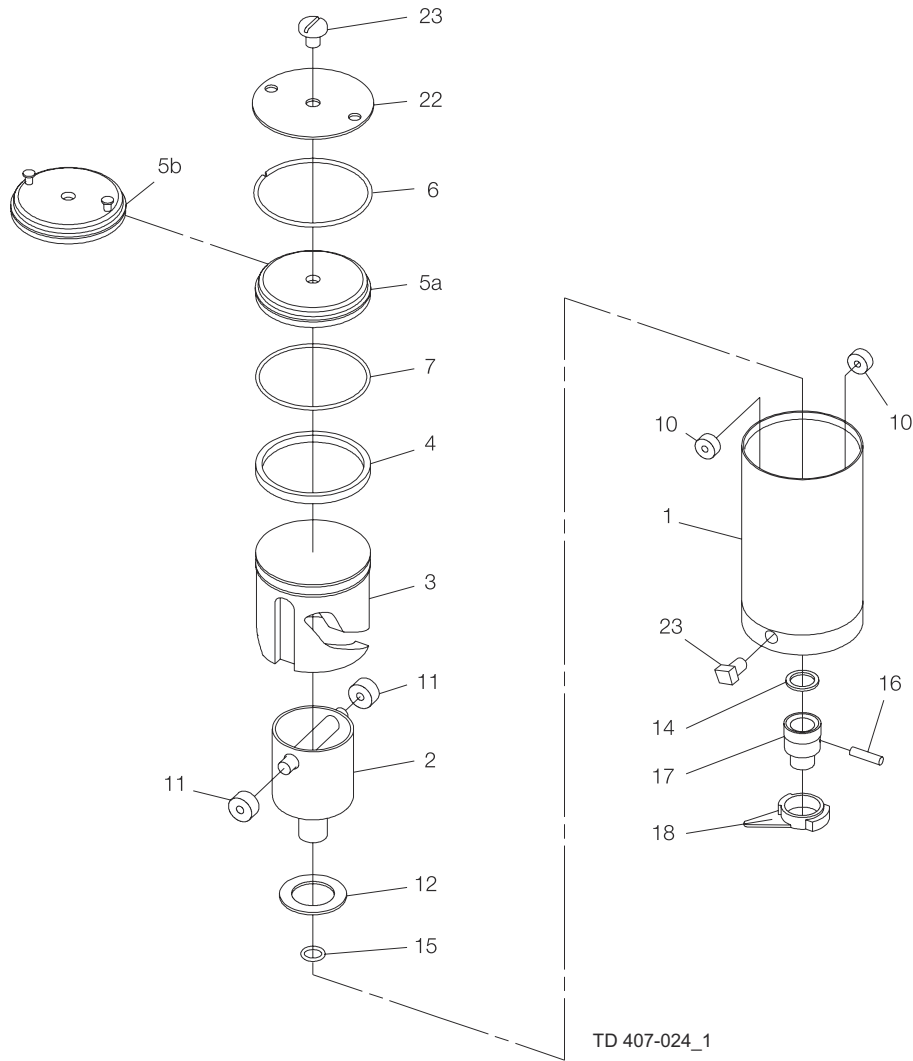

TD 407-024_1

Pos.	Qty.	Denomination
1	1	Air cylinder
2	1	Rotating cylinder
3	1	Piston
4	1	O-ring
5a	1	End cap
5b	1	End cap, Mark III
6	1	Retaining ring
7	1	O-ring
10	2	Needle bearing

Pos.	Qty.	Denomination
11	2	Needle bearing
12	1	Thrust bearing
14	1	Thrust plate
15	1	O-ring
16	1	Connex pin
17	1	Coupling
18	1	Activating ring with screw
22	1	Retaining plate
23	2	Threaded plug

9.12 LKLA, DN 125-150, ø85 mm (A/A)

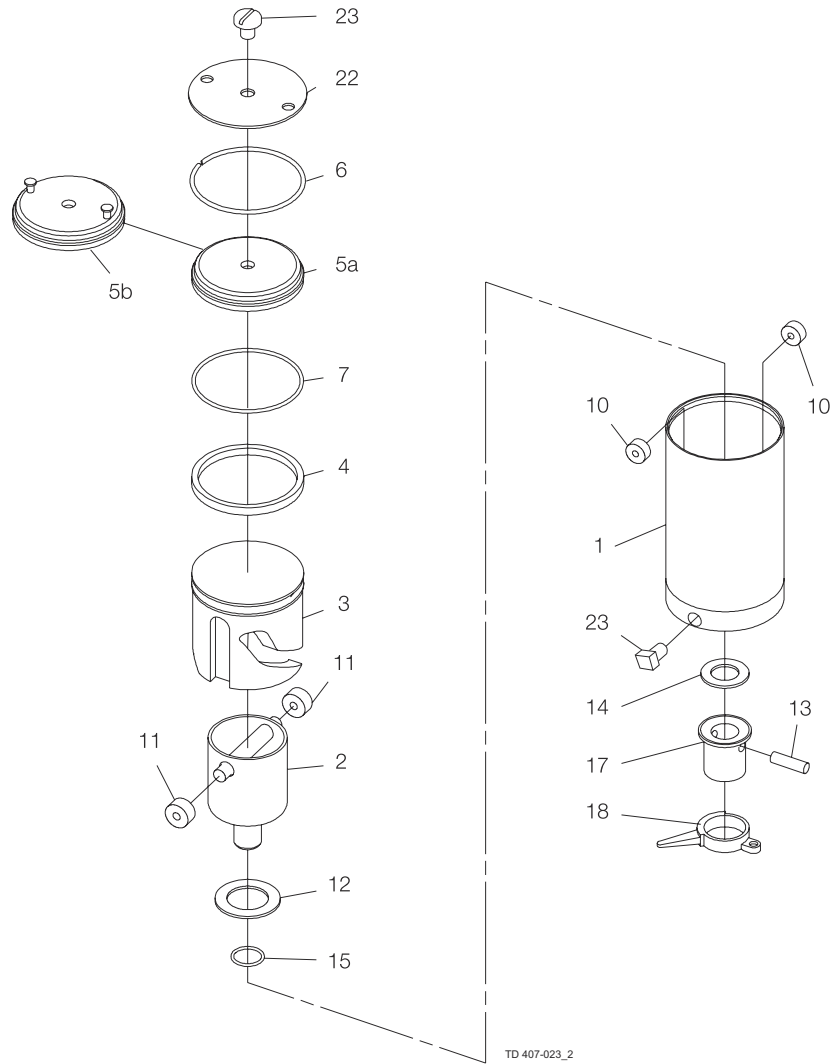

Pos.	Qty.	Denomination
1	1	Air cylinder
2	1	Rotating cylinder
3	1	Piston
4	1	O-ring
5a	1	End cap
5b	1	End cap, Mark III
6	1	Retaining ring
7	1	O-ring
10	2	Needle bearing

Pos.	Qty.	Denomination
11	2	Needle bearing
12	1	Thrust bearing
13	1	Connex pin
14	1	Thrust plate
15	1	O-ring
17	1	Coupling
18	1	Activating ring with screw
22 ¹	1	Retaining plate
23	2	Threaded plug

¹ Up to 8910 supplied without holes, not available anymore

¹ Up to 8910 supplied without holes, not available anymore

9.13 LKLA actuator air/spring (NC-NO) Ø133

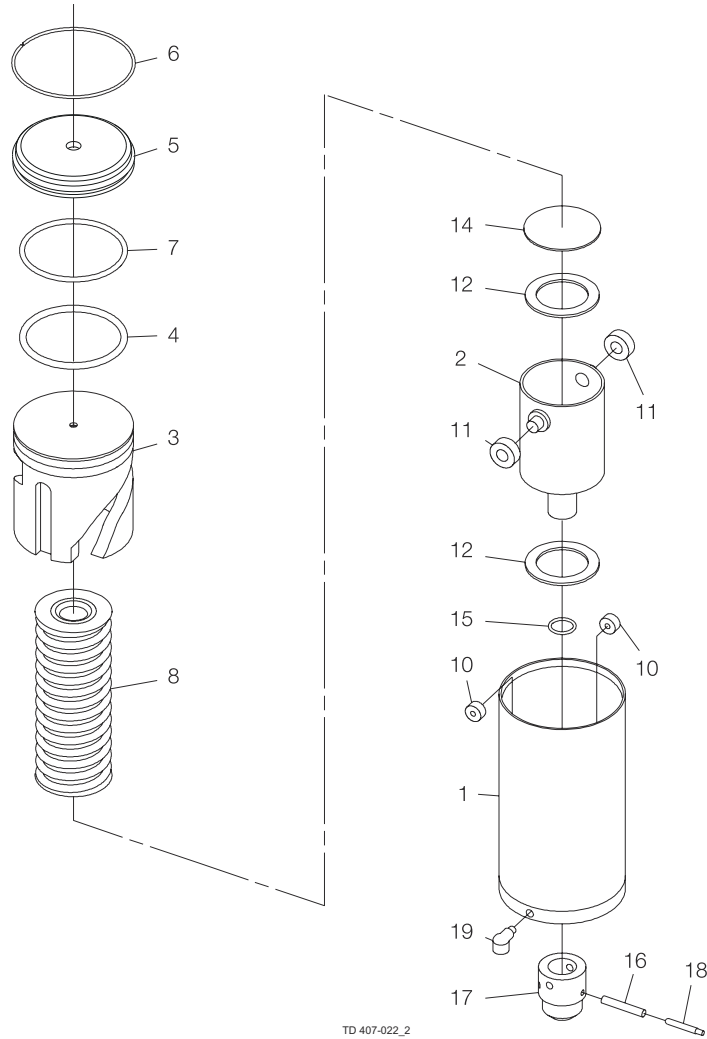

TD 407-022_2

Pos.	Qty.	Denomination
1	1	Air cylinder
2	1	Rotating cylinder
3	1	Piston
4	1	O-ring
5	1	End cap
6	1	Retaining ring
7	1	O-ring
8	1	Spring assembly
10	2	Needle bearing

Pos.	Qty.	Denomination
11	2	Needle bearing
12	2	Thrust bearing
14	1	Thrust plate
15	1	O-ring
16	1	Connex pin
17	1	Coupling
18	1	Indication pin
19	1	Water rejector
21	1	Air fitting

9.14 LKLA actuator air/air Ø133

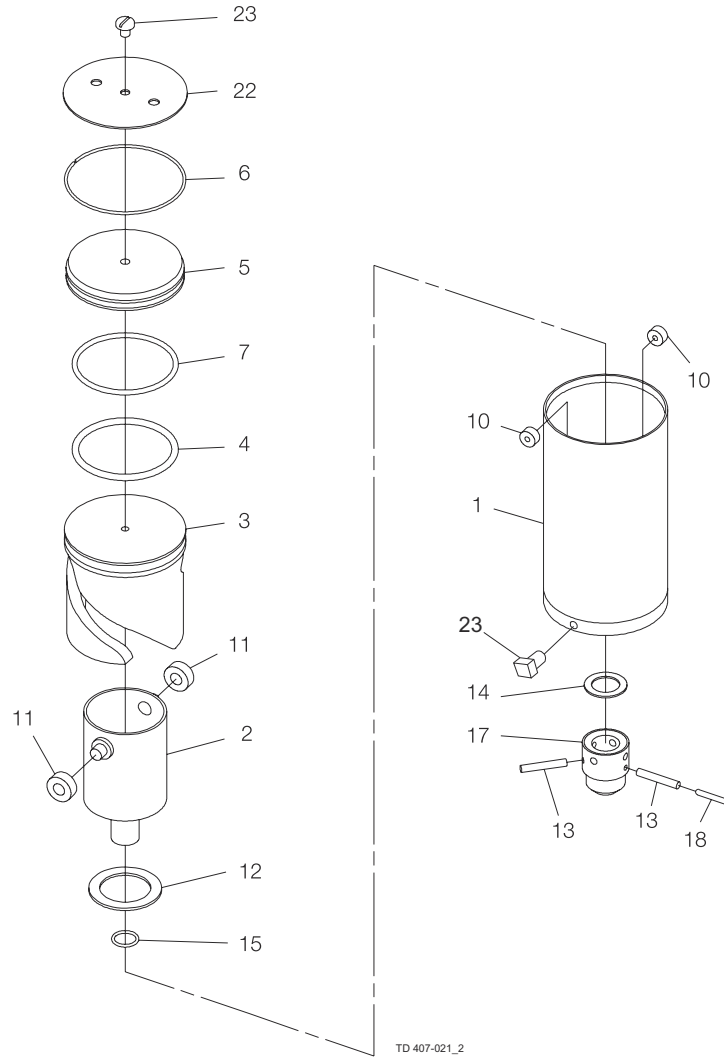

Pos.	Qty.	Denomination
1	1	Air cylinder
2	1	Rotating cylinder
3	1	Piston
4	1	O-ring
5	1	End cap
6	1	Retaining ring
7	1	O-ring
10	2	Needle bearing
11	2	Needle bearing

Pos.	Qty.	Denomination
12	1	Thrust bearing
13	2	Connex pin
14	1	Thrust plate
15	1	O-ring
17	1	Coupling
18	1	Indication pin
22	1	Retaining plate
23	1	Threaded plug

9.15 LKLA-T actuator air/spring (NC-NO) Ø85

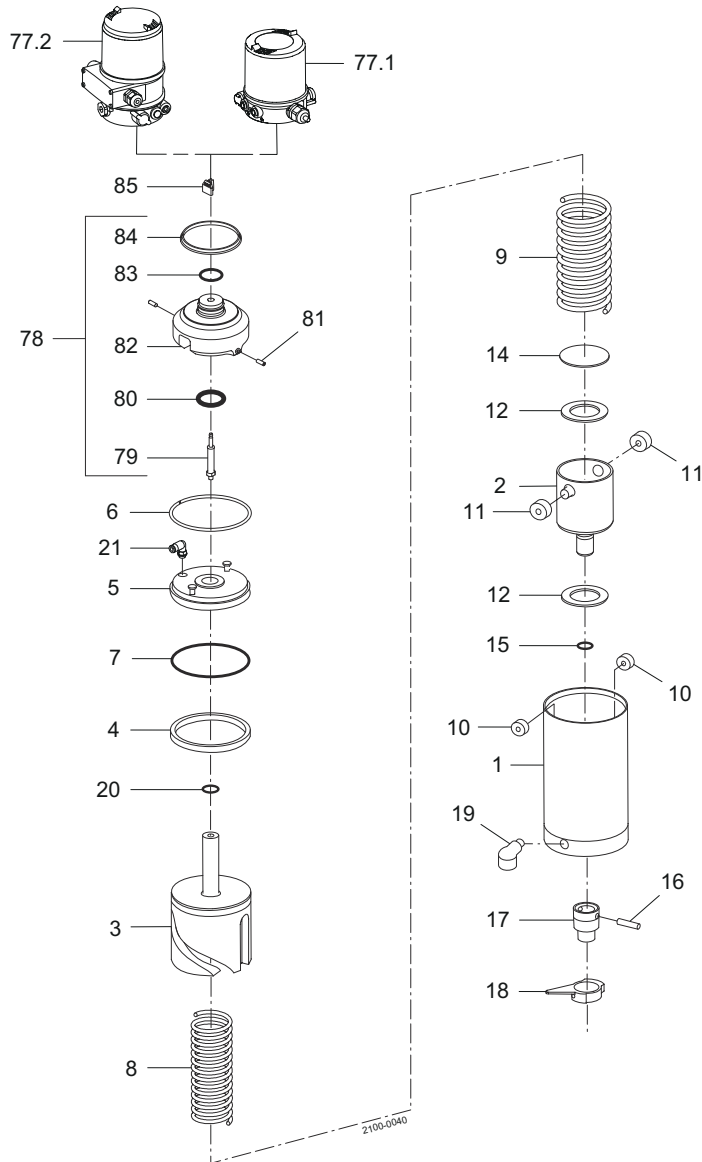

Pos.	Qty.	Denomination
1	1	Air cylinder
2	1	Rotating cylinder
3	1	Piston
4	1	O-ring
5	1	End cap
6	1	Retaining ring
7	1	O-ring
8	1	Inner spring
9	1	Outer spring
10	2	Needle bearing

Pos.	Qty.	Denomination
11	2	Needle bearing
12	2	Thrust bearing
14	1	Thrust plate
15	1	O-ring
16	1	Connex pin
17	1	Coupling
18	1	Activating ring with screw
19	1	Water rejector (period 8310-)
20	1	O-ring
21	1	Air fitting

9.16 LKLA-T actuator air/air Ø85

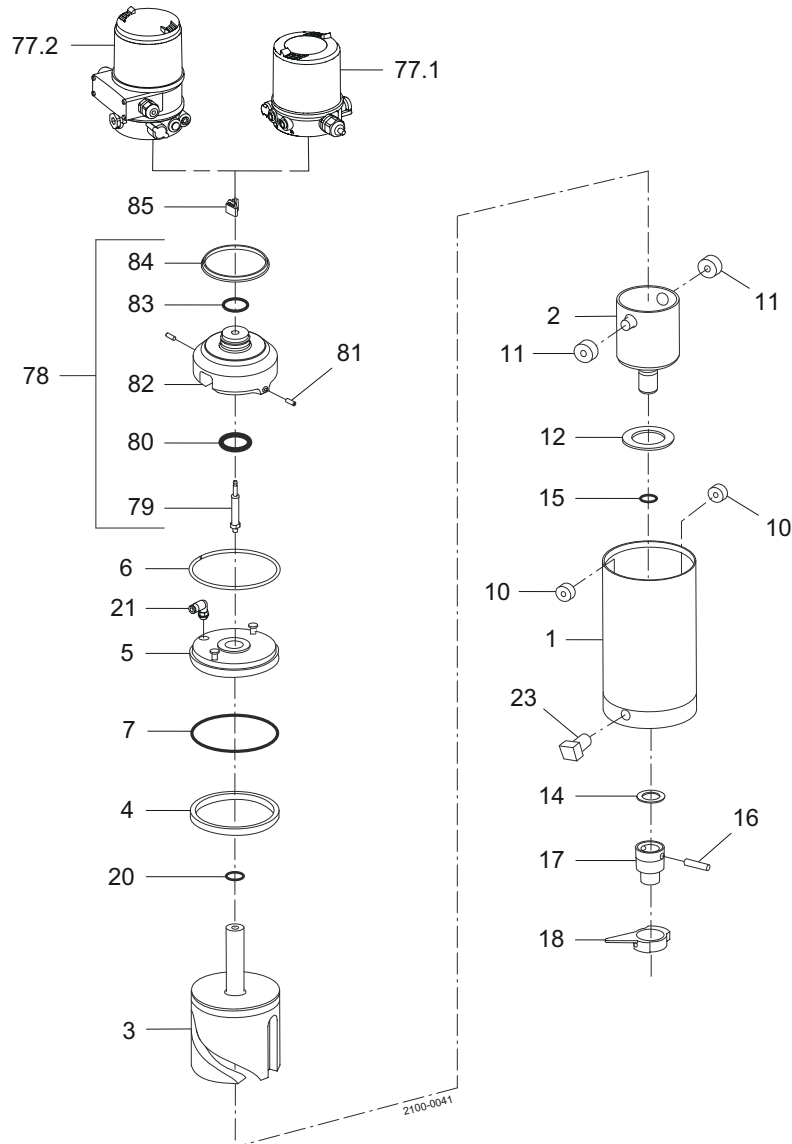

Pos.	Qty.	Denomination
1	1	Air cylinder
2	1	Rotating cylinder
3	1	Piston
4	1	O-ring
5	1	End cap
6	1	Retaining ring
7	1	O-ring
10	2	Needle bearing
11	2	Needle bearing

Pos.	Qty.	Denomination
12	1	Thrust bearing
14	1	Thrust plate
15	1	O-ring
16	1	Connex pin
17	1	Coupling
18	1	Activating ring with screw
20	1	O-ring
21	1	Air fitting
23	1	Threaded plug

9.17 LKLA-T, DN 125-150, ø85 mm (A/A)

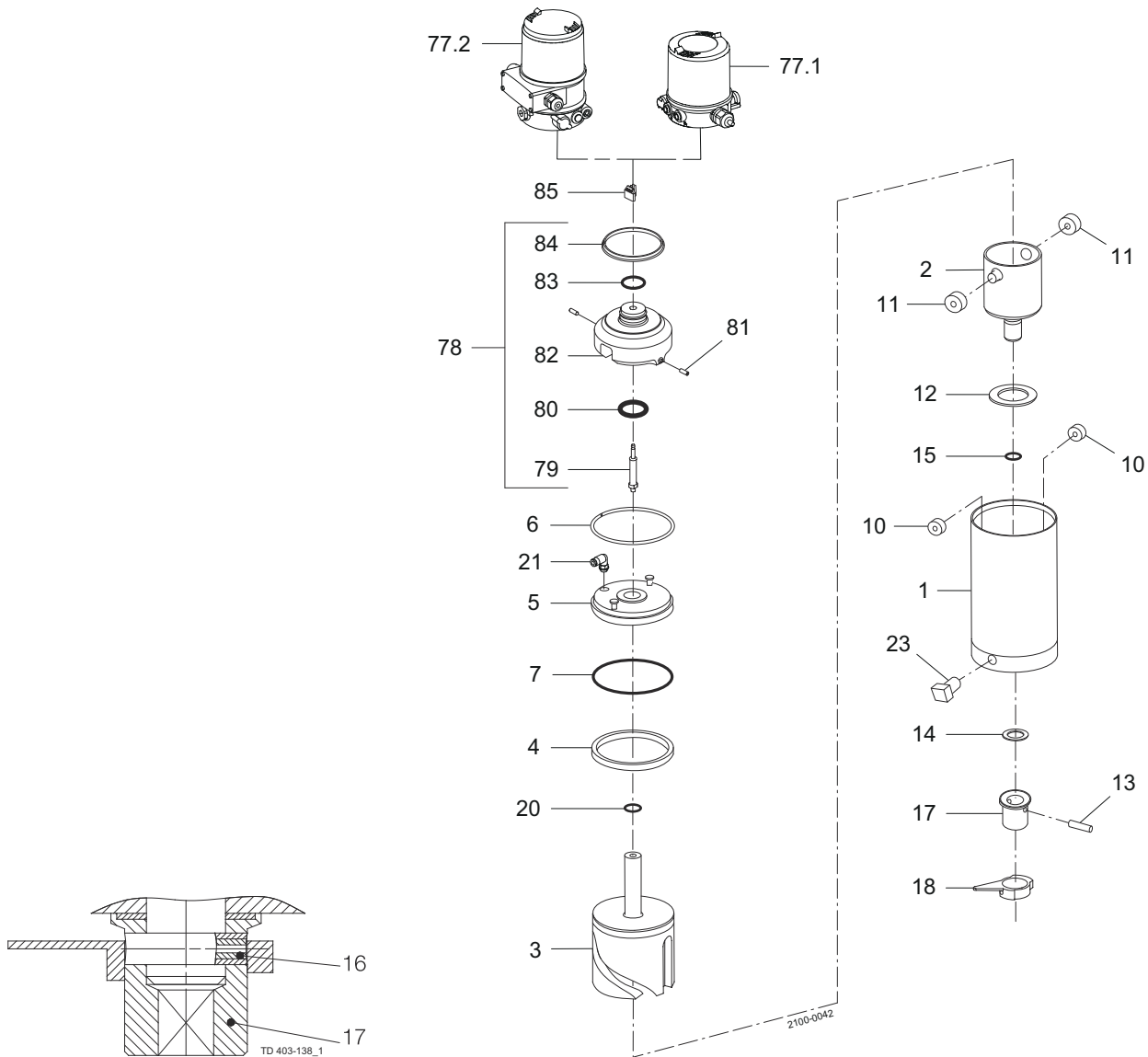

LKLA-T, DN 125-150, ø85 mm (A/A)

Pos.	Qty.	Denomination	Pos.	Qty.	Denomination
1	1	Air cylinder	13	1	Connex pin
2	1	Rotating cylinder	14	1	Thrust plate
3	1	Piston	15	1	O-ring
4	1	O-ring	16	1	Connex pin
5	1	End cap	17	1	Coupling
6	1	Retaining ring	18	1	Activating ring with screw
7	1	O-ring	20	1	O-ring
10	2	Needle bearing	21	1	Air fitting
11	2	Needle bearing	23	1	Threaded plug
12	1	Thrust bearing			

9.18 LKLA-T actuator air/spring (NC-NO) Ø133

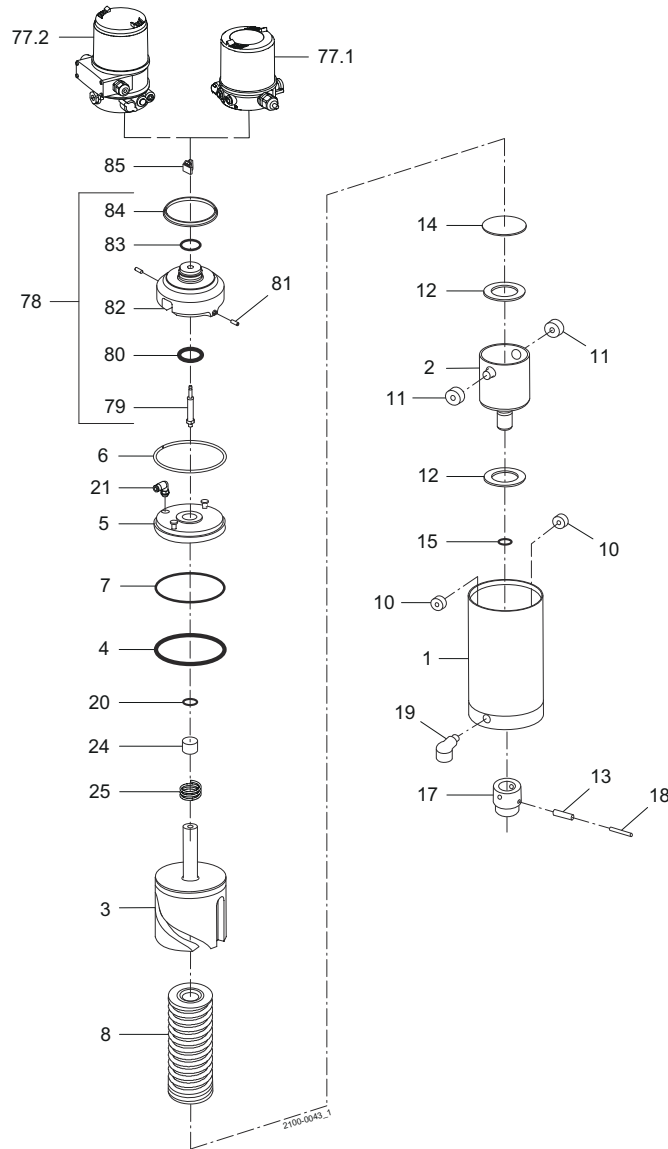

Pos.	Qty.	Denomination
1	1	Air cylinder
2	1	Rotating cylinder
3	1	Piston
4	1	O-ring
5	1	End cap
6	1	Retaining ring
7	1	O-ring
8	1	Spring assembly

Pos.	Qty.	Denomination
10	2	Needle bearing
11	2	Needle bearing
12	2	Thrust bearing
13	1	Connex pin
14	1	Thrust plate
15	1	O-ring
17	1	Coupling
18	1	Indication pin
19	1	Water rejector (period 8310-)
20	1	O-ring
21	1	Air fitting
24	1	Guiding ring
25	1	Spring

9.19 LKLA-T actuator air/air Ø133

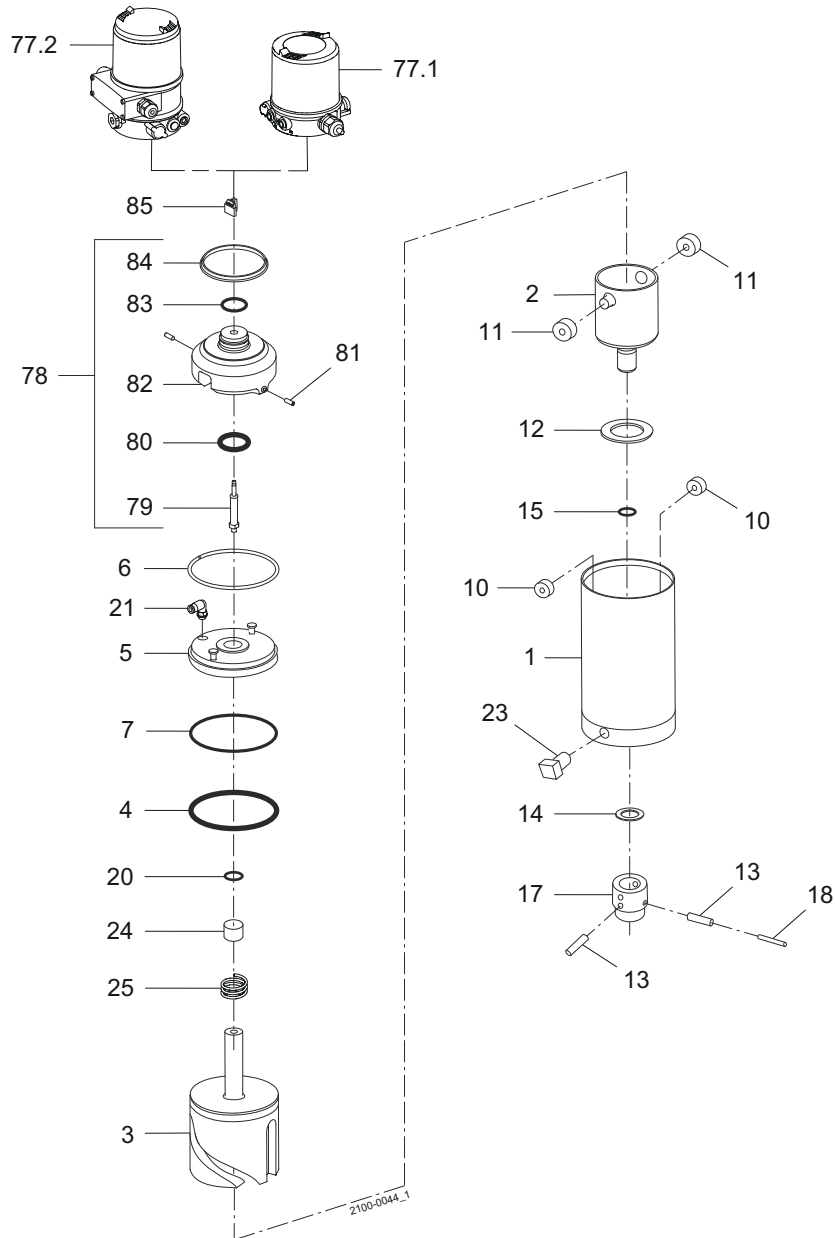

Pos.	Qty.	Denomination
1	1	Air cylinder
2	1	Rotating cylinder
3	1	Piston
4	1	O-ring
5	1	End cap
6	1	Retaining ring
7	1	O-ring
10	2	Needle bearing
11	2	Needle bearing
12	1	Thrust bearing

Pos.	Qty.	Denomination
13	2	Connex pin
14	1	Thrust plate
15	1	O-ring
17	1	Coupling
18	1	Indication pin
20	1	O-ring
21	1	Air fitting
23	1	Threaded plug
24	1	Guiding ring
25	1	Spring