

HEATING INSULATION INCLUDED

Thickness: 45 mm

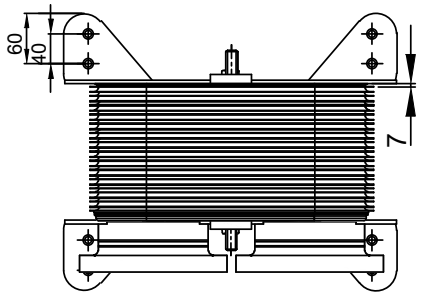
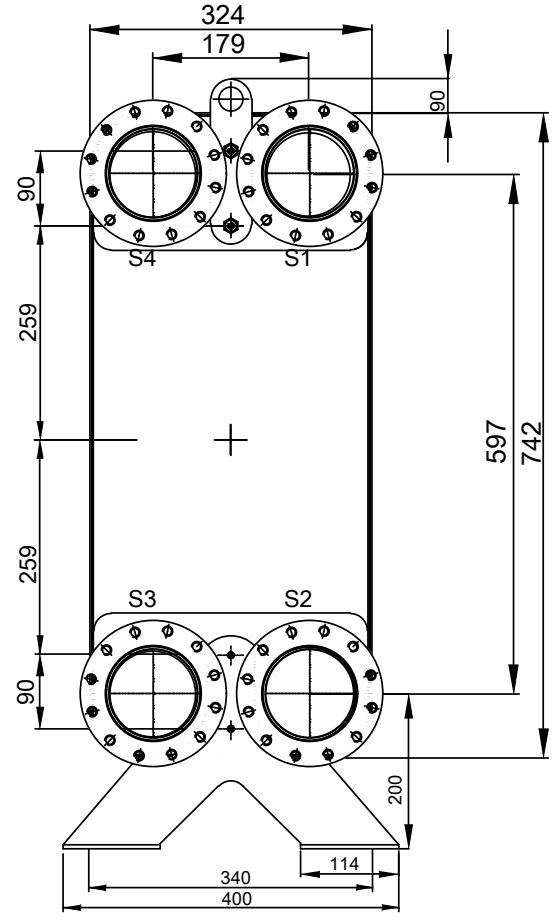
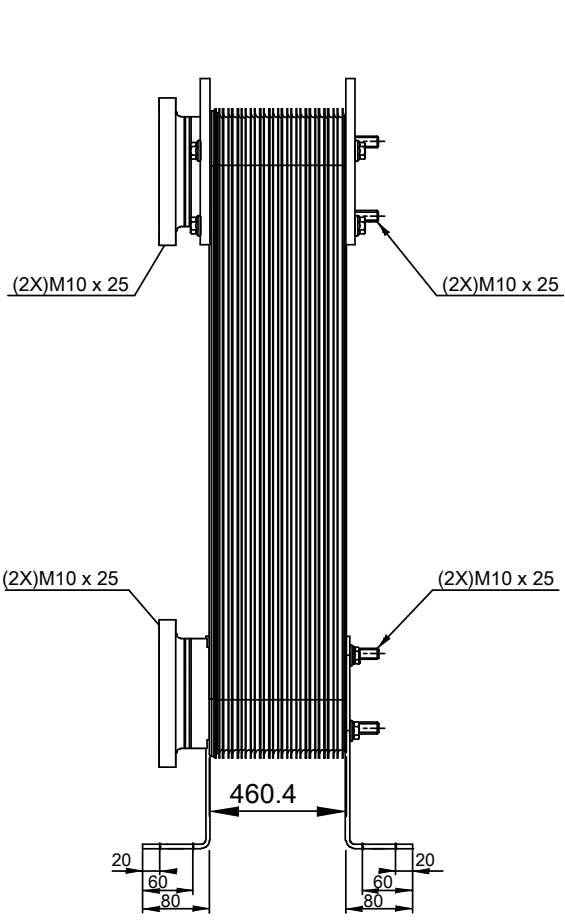

T1 T2 T3 T4 locations on back side correspond to S1 S2 S3 S4 on front side

Note that all unique customer requirements (i.e tolerance) need to be verified thru Alfa Laval.

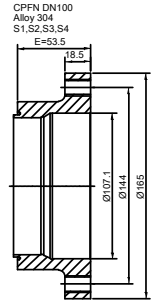

HEATING SURFACE
 NETWEIGHT 152.2 kg
 OPERATING WEIGHT kg
 PLATE MATERIAL ALLOY 316
 PLATE GROUPING 1*104AMH/1*105AML

ALL DIMENSIONS IN MILLIMETERS

SIDE	MEDIA	INLET	TEMP.	OUTLET	TEMP.	FLOW RATE	PRESSURE DROP	LIQUID VOL.
1		S1		S2				66.8 dm³
2		S3		S4				43.3 dm³

PRESSURE VESSEL APPROVAL PED/UK
 CB210-210AM-F (3075034194)



www.alfalaval.com

CUSTOMER NAME / REF. NO.	TOTAL LENGTH	620.4 mm
	TOTAL WIDTH	324.0 mm
COMPANY / REF.	TOTAL HEIGHT	959.0 mm



4/16/2024
 REV 0