

Alfa Laval PureBilge

Oily water cleaning system

Introduction

The Alfa Laval PureBilge solution is a single-stage centrifugal separation system for the treatment of bilge water. Based on a standardized concept, PureBilge is a complete stand-alone system that is easy to install on any new or existing vessel. PureBilge complies with the Marine Environment Protection Committee Resolution, MEPC.107(49), of the International Maritime Organization (IMO) and USCG regulation (46 CFR 106.050).

Application

Cleaning bilge water poses distinct challenges. Not only does the composition and flow of bilge water change, but treatment onboard presents another set of constraints. Treatment methods must meet individual ship requirements and demands for safety, reliability, compactness, automation, low maintenance and the ability to withstand rough weather conditions. Centrifugal separation has proven to be the most reliable, efficient and flexible method for continuous removal of oil and other contaminants suspended in the bilge water.

Benefits

- **Reduced operating costs** thanks to low maintenance, automated control, minimal waste disposal, no chemical consumption and an absence of filter elements that require replacement as standard.
- **Reliable, always-available system.** Operates continuously with high performance, regardless of variations in feed, oil shocks and rough weather conditions.
- **Easy to operate.** Automated control and monitoring system integrates with existing Alfa Laval systems, providing a single user-friendly interface with the latest EPC 70.
- **Safe operation.** A password-locked switch can be set in manual/locked position to ensure that only the individual responsible for environmental compliance may authorize overboard discharge.
- **Compact, modular, easy-to-install system** saves time, space and money.
- **Continuous, single-stage operation** requires less holding tank volume and provides more space for payload.



- **Easy integration** with existing communications systems onboard.
- **Cyber security.** The EPC 70 control system is cyber secure with the required security profile for marine separators. Alfa Laval experts are ready to support when needed.

Design

PureBilge is available in four standard versions:

- PureBilge 2505: 2500l/h, 5ppm
- PureBilge 2515: 2500l/h, 15ppm
- PureBilge 5005: 5000l/h, 5ppm
- PureBilge 5015: 5000l/h, 15ppm

Scope of supply

- Separator module skid
- Feed pump skid
- Electric heater skid, (in case of electric heating media)

Options

- BlueBox Data Recorder
- Sludge removal kit
- Remote operation
- Recovery heater

Working principle

- Forwarding/pumping
- Oily water pre-treatment
- Centrifugal separation
- Process control and monitoring

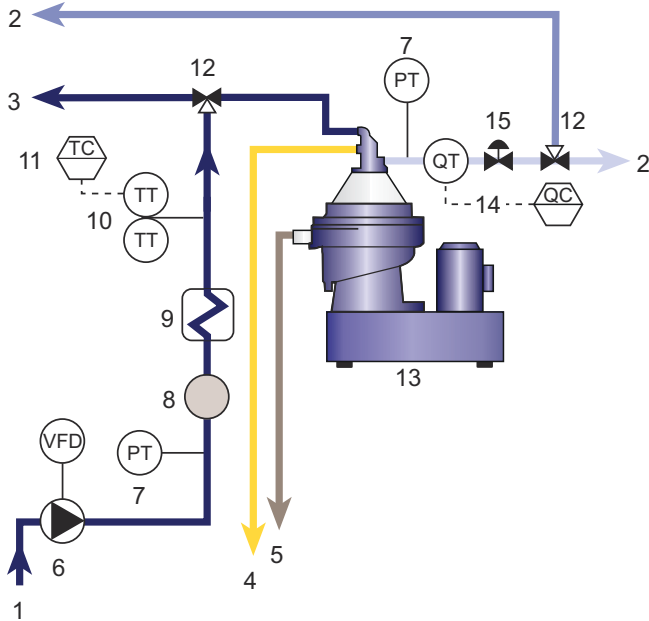

1. Feed inlet
2. Clean water outlet
3. Feed recycling
4. Oil outlet
5. Sludge outlet
6. Feed pump with variable speed control
7. Pressure transmitter
8. Strainer
9. Pre-heater
10. Temperature transmitters
11. Temperature controller
12. Three-way changeover valve
13. BWPX 307 high speed centrifugal separator
14. Oil-in-water monitor
15. Constant pressure modulating valve

Oily water is pumped from the settling tank to the pre-treatment stage by a positive displacement pump with variable frequency drive.

In the pre-treatment stage the bilge water is fed through a basket strainer that traps large particles from the fluid. The fluid then passes through a heat exchanger, which raises the temperature of the fluid to the required level for optimal separation efficiency, generally between 60°C to 70°C.

A three-way changeover valve is located after the heat exchanger in the pre-treatment stage. The purpose of this valve is to direct the fluid to the separation stage when all process conditions, such as feed temperature, pressure and

separator speed match pre-set values. If any condition is not met, the valve will re-circulate the fluid to the bilge water settling tank.

When all process conditions are fulfilled, the fluid is directed to the separation stage. Fluid then enters a high-speed centrifugal separator that is designed for continuous, high-efficiency separation of large volumes of bilge water. Oil and emulsions separated from the bilge water are continuously discharged and directed to a sludge or waste-oil collecting tank. Solids are discharged intermittently through the self-cleaning mechanism of the centrifuge.

Treated water is also continuously discharged. An oil-in-water monitor measures the oil content in the treated bilge water in full compliance with IMO Resolution MEPC.107(49). When the oil content is below a pre-set value (15 ppm or lower), the treated water can be directed either to a holding tank for discharge overboard at the ship operator's convenience, or pumped directly overboard. If the oil content is above the pre-set value, the water is re-circulated to the bilge water settling tank.

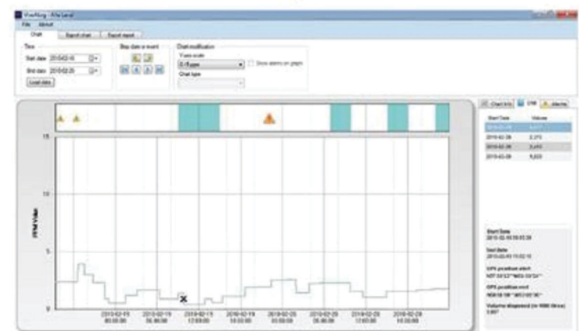
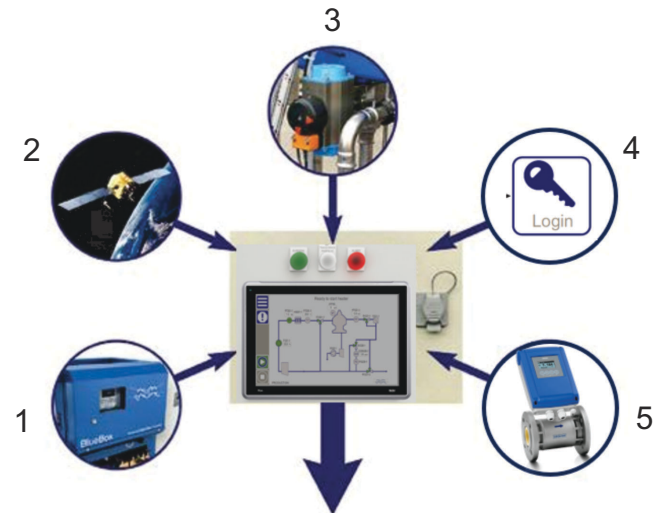

6

1. Tamper proof cover on OCM and complete sample line. Removal/tampering activates alarm and sets overboard valve in recirculation mode
2. GPS position
3. Position switch on overboard valve.
4. Password protected activation of overboard valve
5. Overboard flow meter
6. visuALog software

EPC 70 Bilge process controller

This new generation of the easy-to operate, computer-based Alfa Laval process controller facilitates advanced fully automated monitoring and control of PureBilge functions by displaying in clear text process parameters, alarms and other data.

The controller displays the status of the process, system valves and transmitters, activated or deactivated.

The process controller is based on the same hardware used in other Alfa Laval units, making it easy to use for operators who are already familiar with this equipment.

PureBilge BlueBox Data Recorder

The increasing number of cases where severe penalties have been imposed for discharging bilge water with unacceptably high oil content into the ocean is a growing source of concern for shipping companies.

PureBilge BlueBox Data Recorder is a fully automatic, tamper proof bilge data recorder with visuALog software. The system records oil ppm levels, GPS position, separator operation, full alarm log, overboard valve position and overboard flow data.

Technical data

Power and connections

| | | |
|-------------------|------------------------------|-----------------------|
| Supply voltage | Three-phase, 380V up to 690V | |
| Frequency | 50/60 Hz | |
| Power consumption | 12 kW | |
| Instrument air | G 1/2" | 500–800 kPa |
| Operating water | G 3/4" | 200–800 kPa |
| Cooling water | G 1/2" | 200–800 kPa |
| Oil/water | DN 25 | 100–400 kPa |
| Steam | DN 25 | 700 kPa saturated |
| Thermal oil | DN 25 | 300–600 kPa 220°C max |

Net weight

| | |
|------------------------------------|---------|
| Module complete | 1880 kg |
| Feed pump skid | 150 kg |
| Dosing pumps skid (without liquid) | 40 kg |

Dimensional drawing

Dimensions

| | |
|-----------------------------|----------------------------|
| H1 (minimum lifting height) | 2250 mm (88 ft 37/64 inch) |
| H2 | 1850 mm (72 ft 53/64 inch) |
| W1 | 1615 mm (63 ft 37/64 inch) |
| W2 | 1250 mm (49 ft 7/32 inch) |

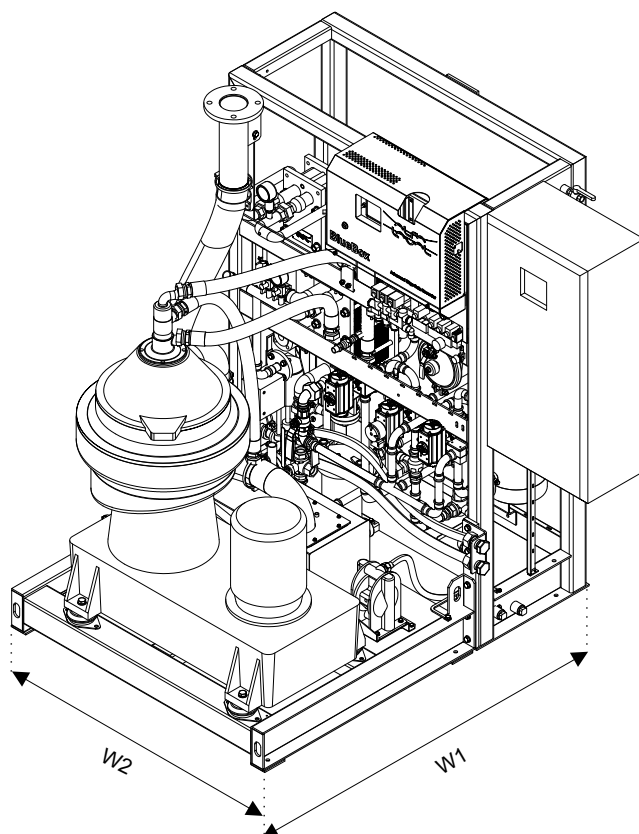
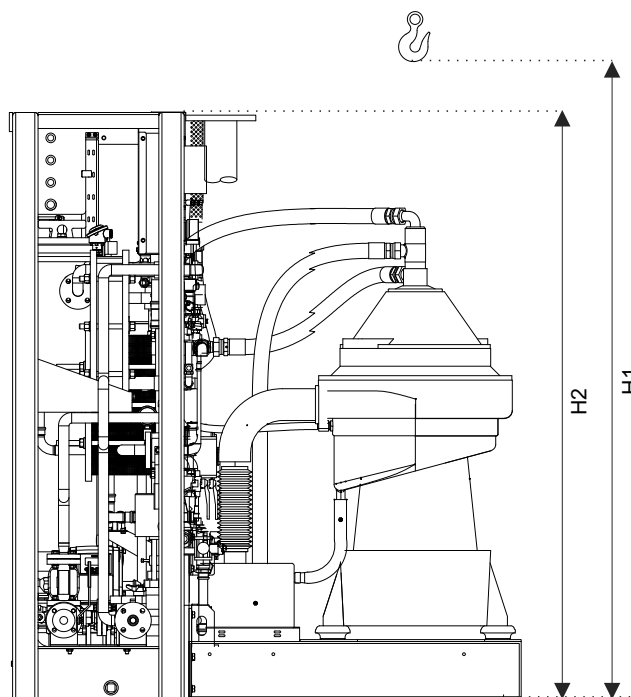

This document and its contents are subject to copyrights and other intellectual property rights owned by Alfa Laval AB (publ) or any of its affiliates (jointly "Alfa Laval"). No part of this document may be copied, re-produced or transmitted in any form or by any means, or for any purpose, without Alfa Laval's prior express written permission. Information and services provided in this document are made as a benefit and service to the user, and no representations or warranties are made about the accuracy or suitability of this information and these services for any purpose. All rights are reserved.

How to contact Alfa Laval

Up-to-date Alfa Laval contact details for all countries are always available on our website at www.alfalaval.com