

Note that all unique customer requirements (i.e tolerance) need to be verified thru Alfa Laval.

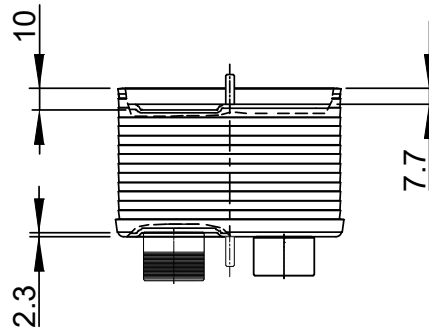

B 23
Alloy 316
S3,S4

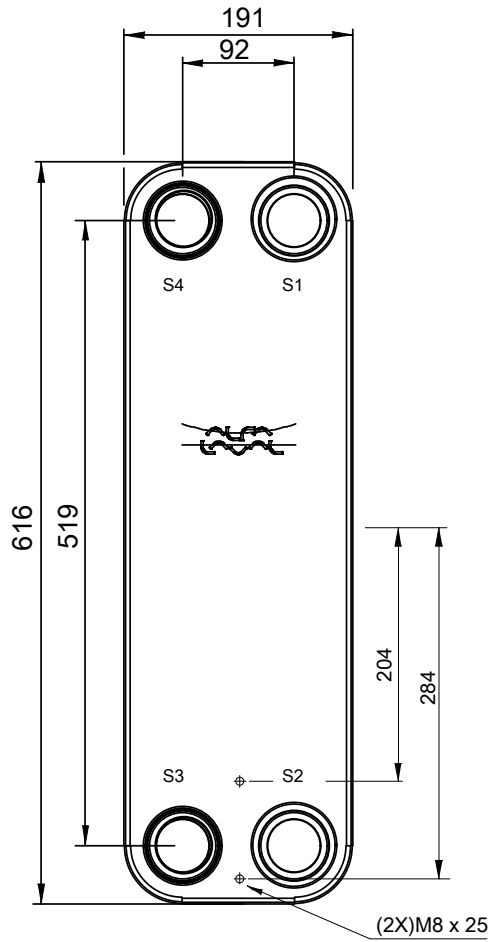
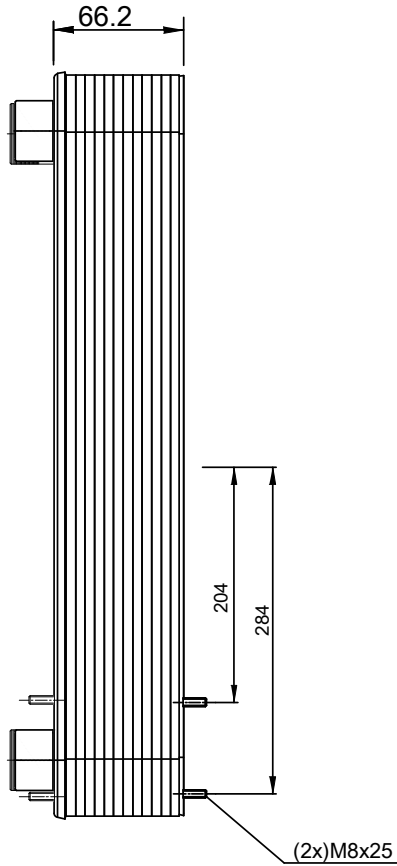
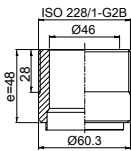

O 5
Alloy 316
S1,S2

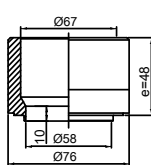

HEATING SURFACE
NETWEIGHT 13.6 kg
OPERATING WEIGHT kg
PLATE MATERIAL ALLOY 316
PLATE GROUPING 1*9L/1*10L

ALL DIMENSIONS IN MILLIMETERS

SIDE	MEDIA	INLET	TEMP.	OUTLET	TEMP.	FLOW RATE	PRESSURE DROP	LIQUID VOL.
1		S1		S2				2.10 dm ³
2		S3		S4				1.89 dm ³

PRESSURE VESSEL APPROVAL

PED

CB110-20L (3287101752)

www.alfalaval.com

CUSTOMER NAME / REF. NO.

TOTAL LENGTH 129.2 mm
TOTAL WIDTH 191.0 mm
TOTAL HEIGHT 616.0 mm

COMPANY / REF.



1/15/2024
REV 0