

Alfa Laval LKHex Prime

Centrifugal pumps

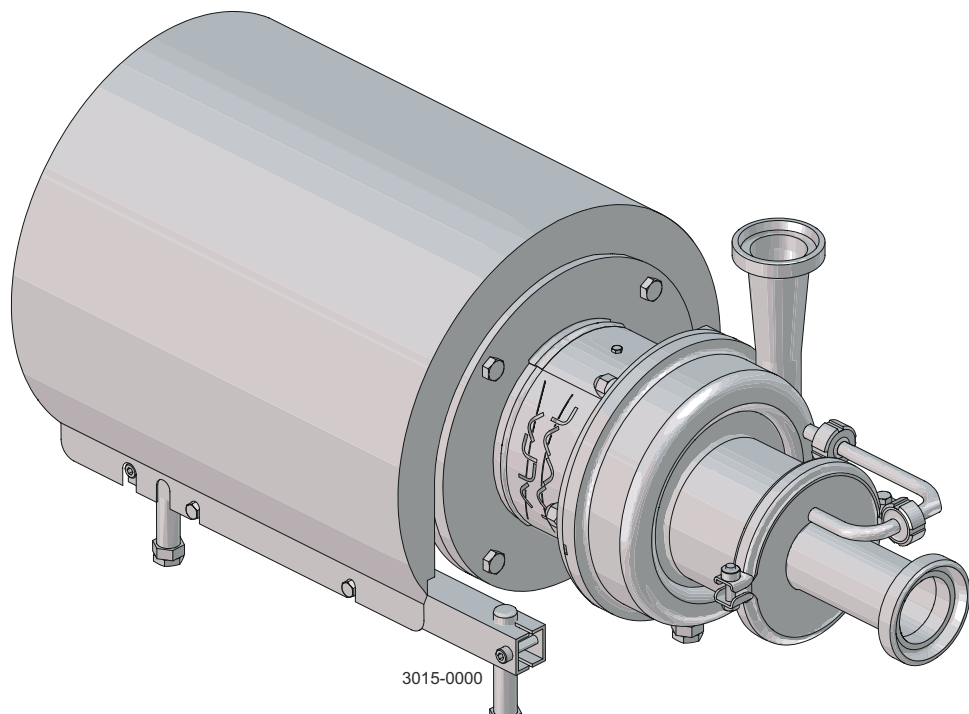

Lit. Code

200007539-3-EN-GB

Instruction Manual

Published by
Alfa Laval Kolding A/S
Albuen 31
DK-6000 Kolding, Denmark
+45 79 32 22 00

The original instructions are in English

© Alfa Laval AB 2026-06

This document and its contents are subject to copyrights and other intellectual property rights owned by Alfa Laval AB (publ) or any of its affiliates (jointly "Alfa Laval"). No part of this document may be copied, re-produced or transmitted in any form or by any means, or for any purpose, without Alfa Laval's prior express written permission. Information and services provided in this document are made as a benefit and service to the user, and no representations or warranties are made about the accuracy or suitability of this information and these services for any purpose. All rights are reserved.

Contents

1	Declarations of Conformity	5
1.1	EU Declaration of Conformity.....	5
1.2	UK Declaration of Conformity.....	6
1.3	ATEX Directive 2014/34/EU.....	7
1.4	ATEX Marking.....	8
2	Safety	9
2.1	Important Information.....	9
2.2	Safety Signs.....	10
2.3	Safety Precautions.....	12
2.4	Special Conditions for Safe Use.....	19
2.5	Warning Signs in Text.....	22
2.6	Requirements of Personnel.....	23
2.7	Recycling Information.....	24
3	Introduction	25
4	Installation	27
4.1	Unpacking/Delivery.....	27
4.2	Installation.....	29
4.3	Pre-use Check.....	37
5	Operation	39
5.1	Important Check and Monitoring During Operation.....	39
5.2	Operating Conditions.....	40
5.3	Operation/Control.....	42
5.4	Troubleshooting.....	44
5.5	Recommended Cleaning.....	45
5.5.1	Cleaning Information.....	46
6	Maintenance	47
6.1	General Maintenance.....	47
6.2	Dismantling of Pump/Shaft Seals.....	49
6.3	Assembly of Pump/Single Shaft Seal.....	53
6.4	Assembly of Pump/Double Mechanical Shaft Seal.....	57
6.5	Adjustment of Shaft.....	61
7	Technical Data	65
7.1	Technical Data.....	65
7.2	Operation Data.....	66
7.3	Technical Information and Description of Mechanical Shaft Seals.....	67

7.4	Relubrication Intervals.....	68
7.5	Torque Specifications.....	68
7.6	Weight (kg).....	69
7.7	Noise emission.....	70
8	Spare Parts.....	71
8.1	Ordering Spare Parts.....	71
8.2	Alfa Laval Service.....	71
8.3	Warranty - Definition.....	72
9	Parts Lists and Exploded Views.....	73
9.1	Sectional drawing and details of the LKHex Prime, Sanitary version.....	73
9.2	Parts list.....	74

1 Declarations of Conformity

1.1 EU Declaration of Conformity

The designated company

Alfa Laval Kolding A/S, Albuen 31, DK-6000 Kolding, Denmark, +45 79 32 22 00

Company name, address and phone number

Hereby declare that

Pump

Designation

LKHex Prime 10, LKHex Prime 20, LKHex Prime 40

Type

AAB000000001-AAB999999999, 332.500-1.000.000

Serial number

is in conformity with the following directives with amendments:



- Machinery Directive 2006/42/EC
- RoHS Directive 2011/65/EU and amendments
- ATEX Directive 2014/34/EU

Pump Marking Options:

For specific marking see pump name plate and refer to "Special Conditions for Safe Use" in instruction manual.

For ATEX Directive 2014/34/EU the following harmonized standards EN ISO 80079-36:2016 and EN ISO 80079-37:2016 for Non-electrical equipment for explosive atmospheres have been applied.

ATEX Directive 2014/34/EU conformity for the motor is covered by the relevant EU Type examination certificate and declaration supplied by the manufacturer.

		II -/2G Ex h IIB T4 -/Gb Ta -20C to +35C
Marking:		II -/2G Ex h IIB T4 -/Gb Ta -20C to +40C
		II -/2G Ex h IIB T3 -/Gb Ta -20C to +40C

The Pump Technical file is stored with: Dancert A/S Gregersensvej, DK-2630 Taastrup, Denmark, Notified Body no.: 1073, Archive no.: 2023-2-0389A

The person authorised to compile the technical file is the signer of this document.

Vice President BU Hygienic Fluid Handling
Head of Product Management

Mikkel Nordkvist

Title

Name

Kolding, Denmark

2026-03-28

Place

Date (YYYY-MM-DD)

Signature



DoC Revison_ 01_032026



1.2 UK Declaration of Conformity

The designated company

Alfa Laval Kolding A/S, Albuen 31, DK-6000 Kolding, Denmark, +45 79 32 22 00

Company name, address and phone number

Hereby declare that

Pump

Designation

LKHex Prime 10, LKHex Prime 20, LKHex Prime 40

Type

AAB000000001-AAB999999999, 332.500-1.000.000

Serial number

is in conformity with the following directives with amendments:

- The Supply of Machinery (Safety) Regulations 2008
- The Restriction of the Use of Certain Hazardous Substances in Electrical and Electronic Equipment Regulations 2012
- The Equipment and Protective Systems Intended for use in Potentially Explosive Atmospheres Regulations 2016

Pump Marking Options:

For specific marking see pump name plate and refer to "Special Conditions for Safe Use" in instruction manual.

For ATEX Directive 2014/34/EU the following harmonized standards EN ISO 80079-36:2016 and EN ISO 80079-37:2016 for Non-electrical equipment for explosive atmospheres have been applied.

ATEX Directive 2014/34/EU conformity for the motor is covered by the relevant EU Type examination certificate and declaration supplied by the manufacturer.

 II -/2G Ex h IIB T4 -/Gb Ta -20C to +35C

Marking:  II -/2G Ex h IIB T4 -/Gb Ta -20C to +40C

 II -/2G Ex h IIB T3 -/Gb Ta -20C to +40C

The Pump Technical file is stored with: Dancert A/S Gregersensvej, DK-2630 Taastrup, Denmark, Notified Body no.: 1073, Archive no.: 2023-2-0389A

Signed on behalf of: Alfa Laval Kolding A/S.

Vice President BU Hygienic Fluid Handling

Head of Product Management

Mikkel Nordkvist

Title

Name

Kolding, Denmark

2026-03-28



Place

Date (YYYY-MM-DD)

Signature

DoC Revison_ 02_032026



1.3 ATEX Directive 2014/34/EU

ATEX Directive 2014/34/EU

The ATEX Directive 2014/34/EU covers equipment and protective systems that will be used in areas endangered by potentially explosive atmospheres created by the presence of flammable gases, vapours and dusts. Centrifugal pumps supplied with an ATEX symbol are classified for use in potentially explosive atmospheres under ATEX Directive 2014/34/EU Group II, Categories 2 and 3.

Technical File Ref: **LKHex Prime - Document reference no. 8010022636.**

Equipment Group and Category: **Group II category 2 G (zone 1)**

Standards used: **EN ISO 80079-36:2016, EN ISO 80079-37:2016**

1.4 ATEX Marking

Name plate example:

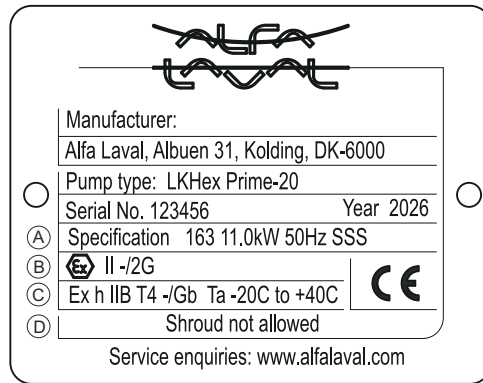

- Ⓐ 163 11.0kW 50Hz SSS
- Shaft seal type (single shaft seal)
 - Motor configuration
 - Impeller diameter (Ø163)

- Ⓑ  II -/2G
- ATEX marking - directive part

- Ⓒ Ex h IIB T4 -/Gb Ta -20C to +40C
- Ambient temperature limit. See instruction manual "Special Conditions for Safe Use" table A
 - ATEX marking - standard part

- Ⓓ Shroud not allowed
- Defines if pump can be with or without shroud. See instruction manual "Special Conditions for Safe use" table A

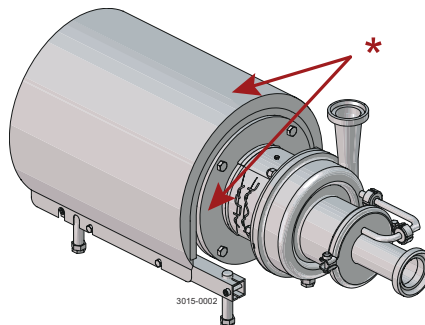

Name plate position



See marking options in *Special Conditions for Safe Use* on page 19, table A.

2 Safety

Read this first

 	<p>This Instruction Manual is designed for operators and service engineers working with the supplied Alfa Laval product.</p> <p>Operators must read and understand the Safety, Installation and Operating instructions of the supplied Alfa Laval product before carrying out any work or before you put the supplied Alfa Laval product into service!</p> <p>Not following the instructions can result in serious accidents.</p> <p>This documentation describes the authorized way to use the supplied Alfa Laval product. Alfa Laval will take no responsibility for injury or damage if the equipment is used in any other way.</p> <p>This Instruction Manual is designed to provide the user with the information to perform tasks safely for all phases in the lifetime of the supplied Alfa Laval product.</p> <p>The operator shall always read the chapter Safety first. Hereafter the operator can skip to the relevant section for the task to be carried out or for the information needed.</p> <p>Always read the chapter Technical Data thoroughly.</p> <p>This is the complete Instruction Manual for the supplied Alfa Laval product.</p>
--	--

NOTE

The illustrations and specifications in this Instruction Manual were effective at the date of printing. However, as continuous improvements are our policy, we reserve the right to alter or modify the Instruction Manual without prior notice or any obligation.

The English version of the Instruction Manual is the original manual. Alfa Laval cannot be held responsible for incorrect translations. In case of doubt, the English version applies.

2.1 Important Information

NOTE

Always read the manual before using the pump!

This Instruction Manual is designed to provide the user with the information to perform tasks safely for all phases in the life time of the product supplied.

The User shall **always** read the safety chapter first. Hereafter the User can skip to the relevant section for the task to be carried out or for the information needed.

This is the complete manual for the supplied product.

2.2 Safety Signs

Mandatory Action Signs

	General mandatory action sign.
	Refer to instruction manual.
	Use ear protection in noisy environments - noise protector.
	Use eye protection - safety glasses.
	Wear protective equipment - safety shoes.
	Use protective hand wear - safety gloves.
	Wear protective equipment - safety helmet.

Warning Signs

	General warning.
	Electricity.
	Transportation with forklift truck or other industrial vehicles if heavy.
	Heavy object lifting.
	Hot surface and burning danger.
	Sharp element.
	Crushing of hands.
	Corrosive substance.





2.3 Safety Precautions

All warnings in the manual are summarised on this page. Pay special attention to the instructions below so that severe personal injury and/or damage to the Supplied Alfa Laval Product is avoided.





General



	<p>Technical data must be observed during installation, operation and maintenance.</p> <p>All personnel should be informed about the technical data.</p> <p>The rules of Intended use are absolute. Use of the supplied Alfa Laval product is allowed only when in compliance with the technical data supplied with the Intended use.</p> <p>Differing utilisation, other than agreed with Alfa Laval Kolding A/S, exclude any liability and warranty.</p> <p>No modification or alteration of the supplied Alfa Laval product is allowed, unless explicit permission is granted by Alfa Laval Kolding A/S.</p> <p>To prevent hazardous reactions between the processed fluid and the materials of construction, the materials of construction must be suitable for the application.</p> <p>The auxiliary equipment chosen for the application must be suitable.</p> <p>Personnel installing, operating or carrying out maintenance on the pump or any sub-component must have the necessary knowledge about the LKHex pump range. Necessary knowledge includes the understanding of:</p> <ul style="list-style-type: none"> • Function of the pump, motor and shaft seal • Maintenance/service of the pump unit, motor and shaft seal • Operational limits for the LKHex pump range • Safety instructions
---	--

Transportation and Lifting





  	<p>Never lift or elevate in any way other than described in this manual.</p> <p>Always use the original packaging or similar during transportation.</p> <p>Always ensure that personnel must have experience with lifting operations.</p> <p>Always transport the pump in its upright position.</p> <p>Always drain the pump head and accessories of any liquid.</p>
 	<p>Always ensure that the unit is securely fixed during transportation.</p> <p>Always ensure the lifting point to be in line with center of gravity. Adjust lifting point if necessary.</p> <p>Always use suitable transport device ie. forklift or pallet lifter.</p> <p>Always use appropriate lifting equipment for heavy parts when relevant.</p> <p>Always keep an eye on the load and stay clear during the lifting operation.</p>

Installation

	<p>If the local safety regulations prescribe that the installation has to be inspected and approved by responsible authorities before the supplied Alfa Laval product is put into service, consult with such authorities before installing the equipment and have the projected installation approved by them.</p> <p>Always read the Technical Data on page 65 thoroughly.</p> <p>Always check the pump before operation. See Pre-use Check on page 37.</p> <p>Check the direction of rotation of the impeller before operation. See the indication label on the pump.</p> <p>Always remove the impeller before checking the direction of rotation.</p> <p>Stay clear and ensure no one is near the shaft during test of rotation.</p> <p>Never start in the wrong direction of rotation with liquid in the pump.</p> <p>Always ensure that the pump unit is suitable for the application and will stay within the specifications in Operating Conditions on page 40 during normal operation.</p> <p>Always design the process system in a way so pressure shocks or over pressure is avoided.</p> <p>The large pump sizes are very heavy. Always use appropriate lifting equipment when handling the pump.</p> <p>Alfa Laval cannot be held responsible for incorrect unpacking.</p> <p>Alfa Laval cannot be held responsible for incorrect installation.</p> <p>Be aware that certain pump configurations can tilt, and therefore cause injuries to feet or fingers. The pump should be supported underneath the adaptor, when not installed in the process line.</p> <p>In case of shaft seal leakage, the media will drip from the slot in the bottom of the adaptor. In case of shaft seal leakage, Alfa Laval recommends putting a drip tray underneath the slot to collect the leakage.</p> <p>The 3A standard requires minimum clearance between the lowest part of the base, pump, motor or drive and for the floor to be no less than 100 mm / 4".</p> <p>The pump does not prevent back flow when intentionally or unintentionally stopped. If back flow can cause any hazardous situations, precautions must be taken e.g. a check valve can be installed in the system preventing hazardous situations.</p> <p>If the pump has been stored for longer period of time there is a risk that the seal faces may stick together and consequently cause damage to the seal at start-up. Please ensure that the pump shaft can be rotated by hand before start-up.</p>
	<p>Never start the pump if the impeller is fitted and the pump casing is removed.</p>
	<p>Always use a lifting crane when handling the pump.</p>
	<p>Always ensure all pipe lines (product, air, and water) are depressurized and emptied before installation, inspection, assembling and disassembling.</p>

	<p>Always have the pump electrically connected by authorised personnel. (See the motor instructions).</p> <p>Alfa Laval recommends the installation of a lockable repair breaker. If the repair breaker is to be used as an emergency stop, the colours of the repair breaker must be red and yellow.</p> <p>Alfa Laval recommends the supply disconnecting device shall be in accordance with EN60204-1. Always disconnect the supply disconnecting device safely after installation before continuing the installation.</p>
	<p>Always ensure the adaptor shield and motor fan guard are present and mounted correctly and allow no access to rotating parts before installing and starting the pump.</p>

Operation

	<p>Always read the <i>Technical Data</i> on page 65 thoroughly.</p> <p>Never run the pump when partially installed or not completely assembled.</p> <p>Necessary precautions must be taken if leakage occurs as this can lead to hazardous situations.</p> <p>Never use the pump for products not mentioned in the Alfa Laval pump selection program.</p> <p>The Alfa Laval pump selection program can be acquired from your local Alfa Laval sales company.</p> <p>Study the instructions carefully and pay special attention to the warnings!</p> <p>Alfa Laval cannot be held responsible for incorrect operation/control.</p> <p>The shaft seal must not run dry.</p> <p>Never throttle the inlet side.</p> <p>The supplied product is designed for cleaning in place (CIP).</p> <p>Use clean water free from chlorides.</p> <p>Always ensure that the pump is operated within the specifications given in <i>Operating Conditions</i> on page 40.</p> <p>Necessary precautions must be taken if leakage occurs as this can lead to hazardous situations.</p> <p>Never restart the pump automatically after a system lockout. At restart, it must be ensured that the pump is running within the specifications given in <i>Operating Conditions</i> on page 40.</p>
	<p>Never run the pump with both the suction side and the pressure side blocked.</p>
	<p>Never touch the supplied product or the pipelines when processing hot liquids or sterilizing.</p> <p>If pumps are sterilised using steam, standard 3A requires the process system to be designed to automatically shut down if the product pressure in the system becomes less than of the atmosphere and it cannot be started until the system is re-sterilised.</p>
	<p>Always follow the instructions in the safety data sheet for the cleaning agent.</p> <p>Always handle lye and acid with great care.</p> <p>The cleaning agents must be stored/disposed of in accordance with current regulations and directives.</p> <p>Always rinse well with clean water after the cleaning.</p>

Maintenance



In order to optimise the operation of the supplied Alfa Laval product and to minimize the down time due repair activities, the maintenance should consist of:

- Inspection and maintenance of the supplied Alfa Laval product: strictly follow the technical documentation
- **Preventive maintenance:** visual inspection of the supplied Alfa Laval product followed by necessary adjustments and planned periodic replacement of wear and tear parts
- **Repairs:** unscheduled break-down of a component, often causing the system to stop. Damaged components shall be replaced or repaired
- **Stock of Alfa Laval genuine spare parts:** Alfa Laval recommend keeping a stock of genuine spare parts facilitating preventive maintenance and reducing down time in case of unplanned break-downs

Always read the *Technical Data* on page 65 thoroughly.

Never service the pump if pressurised.

Always use Alfa Laval genuine spare parts.

Motors with grease nipples:

Always lubricate according to motor manufactures recommended procedures.

Always locate and remove grease vent plugs, if provided, prior to adding grease.

Always check motor nameplate for grease type and lubrication intervals.

Only use the grease type specified on the motor name plate.

For Motor Maintenance, see motor instruction manual.

Maintain the pump carefully.

Study the instructions carefully and pay special attention to the warnings!

Always keep spare shaft seals and rubber seals in stock.

Check the pump for smooth operation after service.

All scrap must be stored/disposed of in accordance with current regulations and directives.



If the pump is supplied with FEP O-rings. Alfa Laval recommends that the casing O-ring is replaced during pump maintenance.

If pump is not supplied with flush connections, the holes in the adaptor must be covered by the guard.

Always make sure that the specifications in *Operation* on page 39 are met before the pump is put back into operation.

Always refer to the pump serial no. on the name plate when ordering spare parts to ensure correct spares.

Always check for any abnormal sounds or running behaviors when starting up the pump after maintenance.

	Never service the pump when it is hot.
	Always disconnect the power supply when servicing the pump. Fit the electrical connections correctly if they have been removed from the motor during service.
	Always follow the instructions in the safety data sheets from the suppliers of cleaning agents, detergents, oils etc. Always follow the instructions in the safety data sheet for the cleaning agent.

Storage

	<p>Alfa Laval recommend:</p> <ul style="list-style-type: none"> • Store the supplied Alfa Laval product as supplied in original packaging • Port opening(s) should be protected against any ingress • Bare steel (not stainless) should be lightly oiled/greased • Store in a clean, dry place without direct sunlight or UV light • Temperature range -5 °C to +40 °C / +23 °F to +104 °F • Relative humidity less than 60% • No exposure to corrosive substances (including contained air)
---	--

Noise

	Under certain operating conditions, the supplied Alfa Laval product and/or the systems in which they are installed can produce high sound pressure levels. Appropriate noise protection measures should be taken when necessary and in accordance with local legislation.
---	---

Safety check

	<p>A visual inspection of any protective device (shield, guard, cover or other) on the supplied Alfa Laval product shall be carried out at least every 12 months. If the protective device is lost or damaged, especially when this leads to deterioration of safety performance, it shall be replaced. The fixing of the protective device should only be replaced with fixings of the same or an equivalent type.</p> <p>Inspection acceptance criteria:</p> <ul style="list-style-type: none"> • It should not be possible to reach moving parts originally protected by a protective device • The protective device must be securely mounted • Ensure that screws for the protective device are securely tightened <p>Procedure in case of non-acceptance:</p> <ul style="list-style-type: none"> • Fix and/or replace the protective device
---	--

2.4 Special Conditions for Safe Use

All warnings in the manual are summarised in this section.

Pay special attention to the instructions below so that severe personal injury and/or damage to the pump are avoided.

General



- Always** read *Operating Conditions* on page 40.
- Always** ensure that the pump is liquid filled (primed) at start-up, see *Installation* on page 27.
- Never** pump flammable process media (see flash points in table A).
- Never** run the pump with neither the suction side nor the pressure side blocked.
- Always** ensure that the pump is liquid filled when operating, unless a doubled mechanical seal is fitted (See table B).
- Never** mount shroud on the pump if the name plate states "shroud not allowed".
- Always** stop the pump if:
- operating outside the given limits of the critical temperature range of process media (See table A).
 - operating outside the given limits of the flush media temperature or flow rate (See table B).
 - **Note** it must be ensured that the flow and temperature limits for the process media or flush media are maintained when the pump is operating. If this cannot be ensured in any other way, the flow and temperature should be continuously monitored.

WARNING



In case of seal failure, leakage may occur. If this can lead to hazardous situations, the risk must be evaluated and necessary precautions must be taken. (See *Technical Information and Description of Mechanical Shaft Seals* on page 67).

NOTE

the motor is a separate certified ATEX product and covered by EU-type examination certificate and must be handled according to the specifications in the motor instruction manual.

Safety Critical Limitations for Specific ATEX Markings.

Table A

Pump marking options	Ambient temperature	Critical temperature range of process media
 II -/2G Ex h IIB T4 -/Gb Ta -20C to +35C	-20 °C to +35 °C (Shroud allowed) ¹	-10 °C to +100 °C
 II -/2G Ex h IIB T4 -/Gb Ta -20C to +40C	-20 °C to +40 °C (Shroud NOT allowed)	-10 °C to +100 °C
 II -/2G Ex h IIB T3 -/Gb Ta -20C to +40C	-20 °C to +40 °C (Shroud allowed)	-10 °C to +140 °C

¹ For pumps with temperature class T4 and with 18.5kW motors or larger, shroud is not allowed (independent of ambient temperature).

NOTE

For T4 applications the pump casing and seal housing can be sterilized to max 125 °C when the pump is NOT operating.

NOTE

Ensure that the chosen elastomer is compatible with the process media and the media temperature (see [Operating Conditions](#) on page 40 for more information).

NOTE

The LKHex Prime can only be marked for category 2G but can be used for 3G applications also.

Requirements for Measurements on the Process Media

- The temperature sensor position (S1) for the process media must be placed max 0.5m away from the outlet.
- The pump must be stopped if the flow of the process media is less than 0.5m³/h for more than 15 minutes.

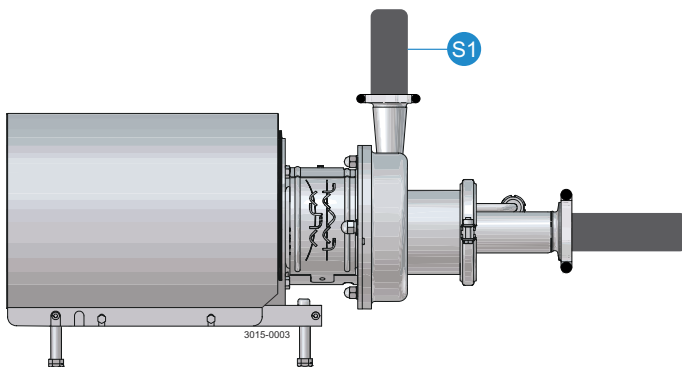

Requirements for Measurements on the Flush Media (Double Mechanical Shaft Seal)

Table B Flush media limitations

Max. temperature	100 °C
Min. flow rate	30 l/h
Max. pressure	5 bar

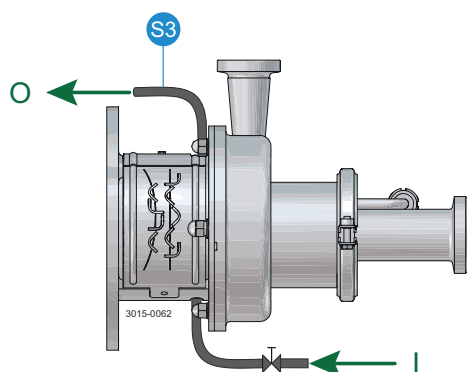

NOTE

Flush media temperature must be measured no more than 2m away from the flush housing outlet.

Pumps mounted with double mechanical shaft seals can, periodically, operate without the pump casing being completely liquid filled since the seal faces are lubricated and cooled by the flush media.

“b1” control system requirements

Measurement system shall be chosen according to EN ISO 80079-37:2016.

Always test and validate the control system before production start-up.

The ignition protection system performance requirements:

Temperatures:

- +/- 2 °C
- 30s reaction time

Flow:

- +/- 10%
- 30s reaction time

The demand for the ignition protection system b1 must be according to EN ISO 13849-1:2023 PL c cat. 2 or IEC 61508:2010 SIL 1 and must be calibrated and functionally tested on a yearly basis.

2.5 Warning Signs in Text

Pay attention to the safety instructions in this Instruction Manual.

Below are definitions of the four grades of warning signs used in the text where there is a risk for injury to personnel or damage to the supplied Alfa Laval product.

 **DANGER**

Indicates an imminently hazardous situation which, if not avoided, will result in death or serious injury.

 **WARNING**

Indicates a potentially hazardous situation which, if not avoided, could result in death or serious injury.

 **CAUTION**

Indicates a potentially hazardous situation which, if not avoided, may result in minor or moderate damage to the supplied Alfa Laval product.

 **NOTE**

Indicates important information to simplify or clarify procedures.

2.6 Requirements of Personnel

Operators

The operators shall read and understand this Instruction Manual.

Maintenance personnel

The maintenance personnel shall read and understand this Instruction Manual. The maintenance personnel or technicians shall be skilled within the field required to carry out the maintenance work safely.

Trainees

Trainees can perform tasks under the supervision of an experienced employee.

People in general

The public shall not have access to the supplied Alfa Laval product.

In some cases, specially skilled personnel may need to be hired (i.e. electricians, welders). In some cases the personnel has to be certified according to local regulations with experience of similar types of work.

2.7 Recycling Information

Unpacking

Packing material may consist of wood, plastics, cardboard boxes and in some cases metal straps.

	<ul style="list-style-type: none"> • Wood and cardboard boxes can be reused, recycled or used for energy recovery • Plastics should be recycled or burnt at a licensed waste incineration plant • Metal straps should be sent for material recycling
---	---

Maintenance

During maintenance, oil (if used) and wear parts in the supplied Alfa Laval product should be replaced.

- Oil and all non-metal wear parts must be disposed of in accordance with local regulations
- Rubber and plastics should be burnt at a licensed waste incineration plant. If not available they should be disposed of in accordance with local regulations
- Bearings and other metal parts should be sent to a licensed handler for material recycling
- Seal rings and friction linings should be disposed of to a licensed land fill site. Check your local regulations
- All metal parts should be sent for material recycling
- Worn out or defected electronic parts should be sent to a licensed handler for material recycling

Scrapping

At end of use, the equipment must be recycled in accordance with the relevant local regulations. Besides the equipment itself, any hazardous residues from the process liquid must be considered and dealt with in a proper manner. When in doubt, or in the absence of local regulations, please contact your local Alfa Laval sales company.

How to contact Alfa Laval

Contact details for all countries are continually updated on our website.

Please visit www.alfalaval.com to access the information directly.

3 Introduction

The Alfa Laval LKHex Prime Centrifugal Pump is a versatile, highly efficient self-priming pump for use in hygienic applications, which must meet the requirements of the ATEX directive 2014/34/EU group II, category 2G, temperature class T3 and T4. With its combination of air screw technology and advanced design, the pump can remove air from the suction pipe.

Precision-engineered, the LKH Prime delivers greater energy efficiency than similar pumps. Its optimized design, premium motor, tight tolerances and advanced impeller and airscrew design minimize recirculation and reduce energy consumption.

This page is intentionally left blank.

4 Installation

4.1 Unpacking/Delivery

WARNING

Be aware that certain pump configurations can tilt, and therefore cause injuries to feet or fingers. The pump should be supported underneath the adaptor, when not installed in the process line.

CAUTION

Alfa Laval cannot be held responsible for incorrect unpacking.

Always use a lifting crane when handling the pump.

NOTE

The large pump sizes are very heavy. **Always** use appropriate lifting equipment when handling the pump.

Check the delivery for:

- Complete pump
- Delivery note
- Motor instructions

- 1 Remove any packing materials from the inlet and the outlet.

Avoid damaging the inlet and the outlet.

Avoid damaging the connections for flushing liquid, if supplied.

*) Remove packing materials!

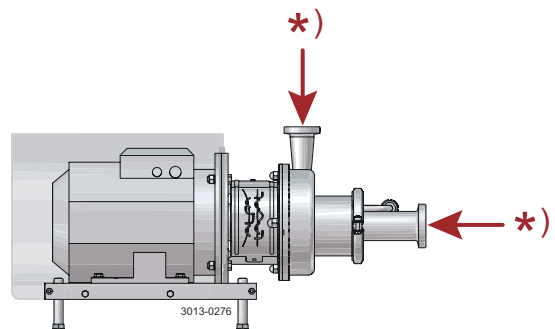

- 2 Inspect the pump for visible transport damage.

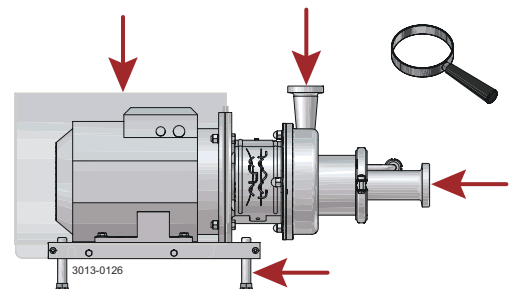

- 3 Always remove the shroud, if fitted, before lifting the pump.

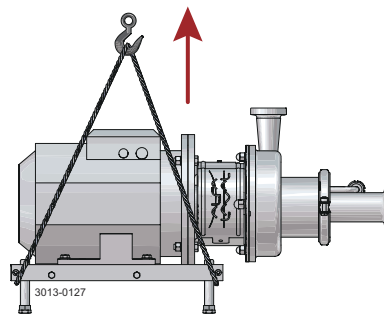

4.2 Installation

WARNING

Always have the pump electrically connected by authorised personnel. (See the motor instructions).

Alfa Laval recommends the installation of a lockable repair breaker. If the repair breaker is to be used as an emergency stop, the colours of the repair breaker must be red and yellow.

Alfa Laval recommends the supply disconnecting device shall be in accordance with EN60204-1. Always disconnect the supply disconnecting device safely after installation before continuing the installation.

The pump unit must be connected to earth before operation.



WARNING

Check nameplate and make sure that the pump is labelled according to the particular application where it is going to be used.

In order to prevent the pump from operating under abnormal conditions, an ATEX-compliant protection system must be installed. The system must comply with EN ISO 80079-37:2016 or similar standards.

Always use ATEX-compliant installation material.

CAUTION

Alfa Laval cannot be held responsible for incorrect installation.

Always use a lifting crane when handling the pump.

The pump does not prevent back flow when intentionally or unintentionally stopped. If back flow can cause any hazardous situations, precautions must be taken e.g. a check valve can be installed in the system preventing hazardous situations.

If the pump has been stored for longer period of time there is a risk that the seal faces may stick together and consequently cause damage to the seal at start-up. Please ensure that the pump shaft can be rotated by hand before start-up.

NOTE

Study the instructions carefully and pay special attention to the warnings!

Always read the [Technical Data](#) on page 65 thoroughly.

Always check the pump before operation. See [Pre-use Check](#) on page 37.

The large pump sizes are very heavy. **Always** use appropriate lifting equipment when handling the pump.

In case of shaft seal leakage, the media will drip from the slot in the bottom of the adaptor. In case of shaft seal leakage, Alfa Laval recommends putting a drip tray underneath the slot to collect the leakage.

The 3A standard requires minimum clearance between the lowest part of the base, pump, motor or drive and for the floor to be no less than 100 mm / 4".

- 1 Ensure at least 0.5 m /1.6' clearance around the pump.

Ensure the floor/frame is able to support the weight of the pump. See *Technical Data* on page 65.

Ensure the pump is supported by all four feet equally.

DO NOT fixate the motor and/or leg bracket to floor and/or frame.

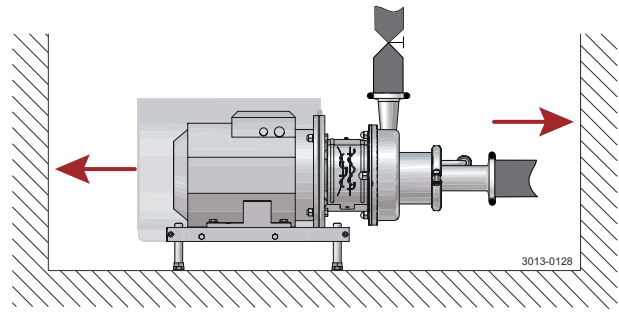

- 2 Check that the flow direction is correct.

O: Outlet

I: Inlet

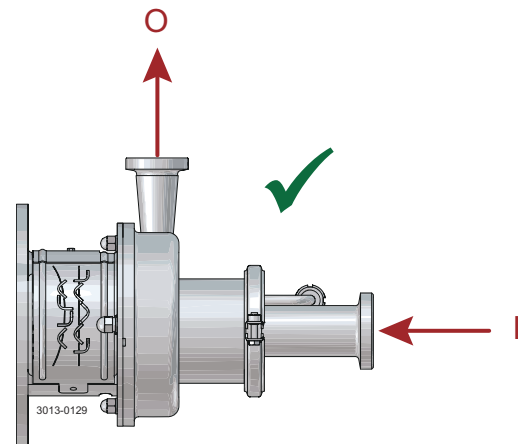

- 3
- Ensure that the pipelines are routed correctly.
 - Ensure that the connections are tight.
 - Remember seal rings. Few bends.

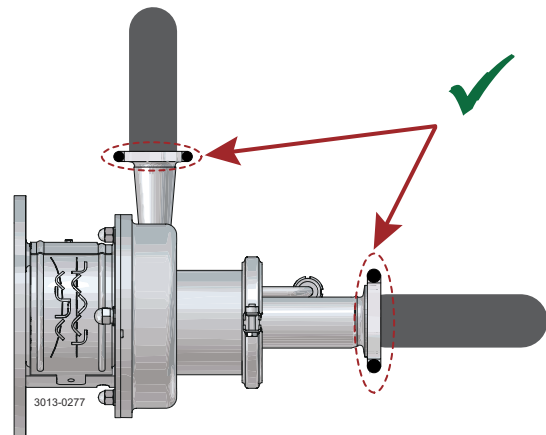

- 4 Avoid stress on the pump.
Piping system must be self-supported.

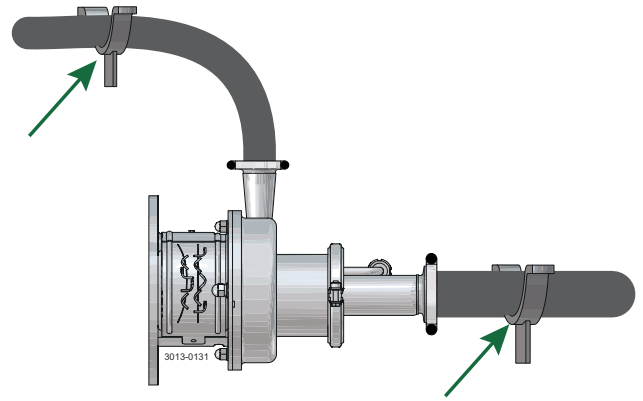

Pay special attention to:

- Vibrations
- Thermal expansion of the tubes
- Excessive welding
- Overloading of the pipelines

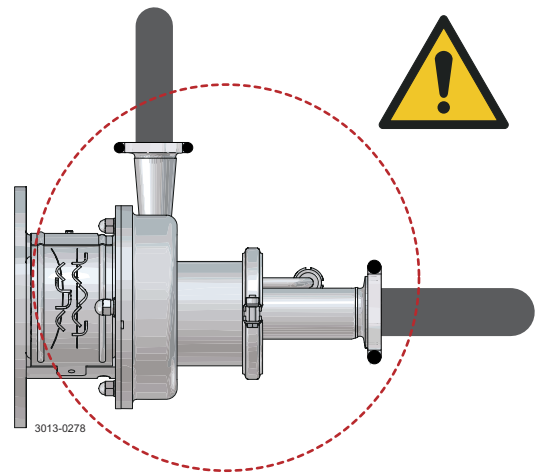

- 5 Ensure correct alignment of pump inlet and outlet with piping system.

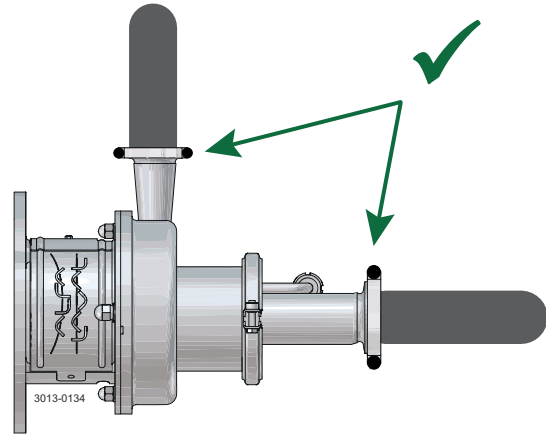

Alignment can be done by adjusting the pump legs.

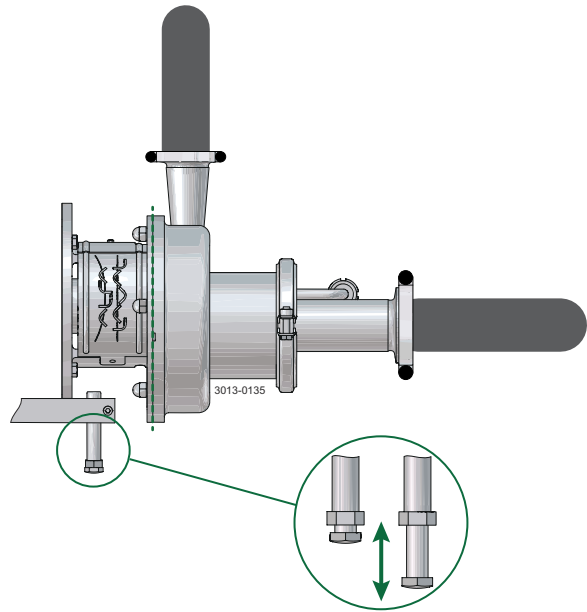

Centre of inlet and outlet to be aligned with centre of piping system.

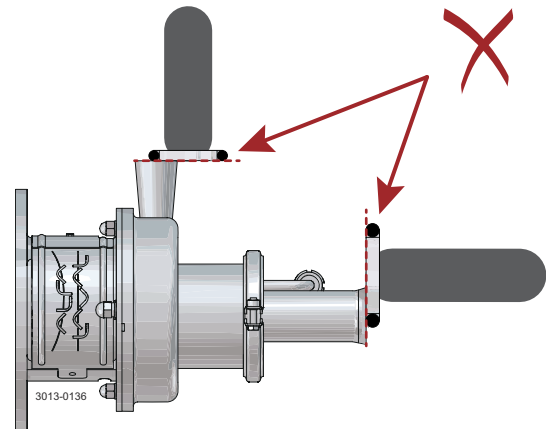

No gaps between connections on pump inlet and inlet pipe, and pump outlet and outlet pipe.

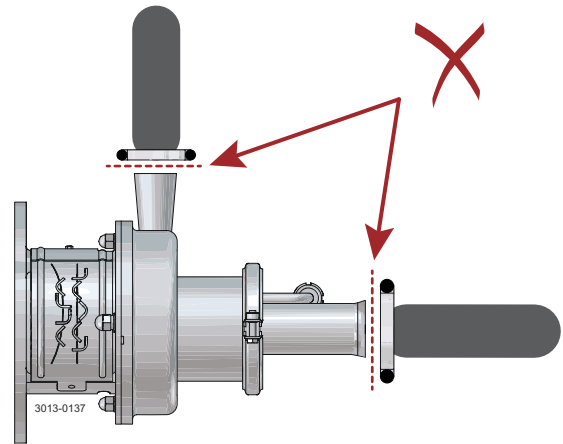

Angle between connections on pump inlet and inlet pipe, pump outlet and outlet pipe not allowed.

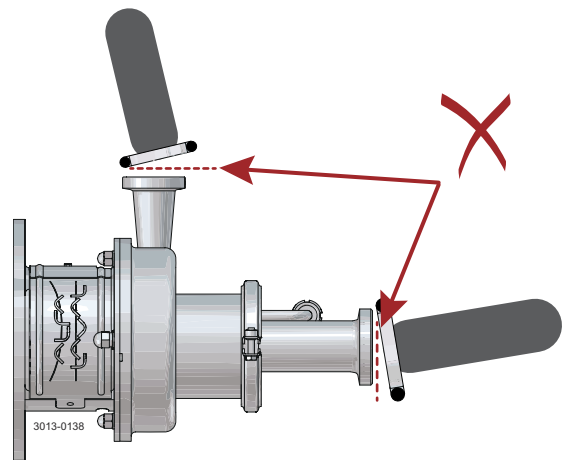

6 Ensure correct alignment of pump casing and pump backplate.

Angle not allowed.

Alignment can be done by adjusting the pump legs.

Ensure stud bolts in casing are aligned with holes in backplate.

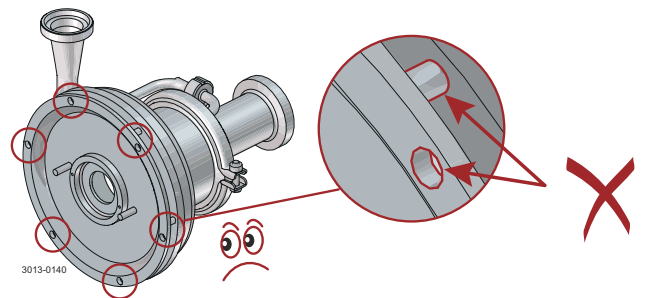
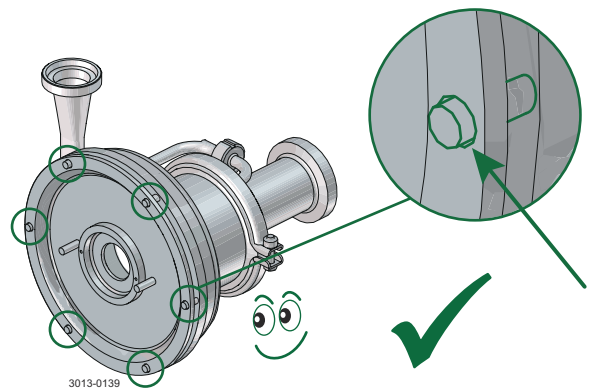

- 7 If equipped with drain option:
 Never short circuit the drain connections as this will reduce the air release capacity.
 Always use two drain valves.

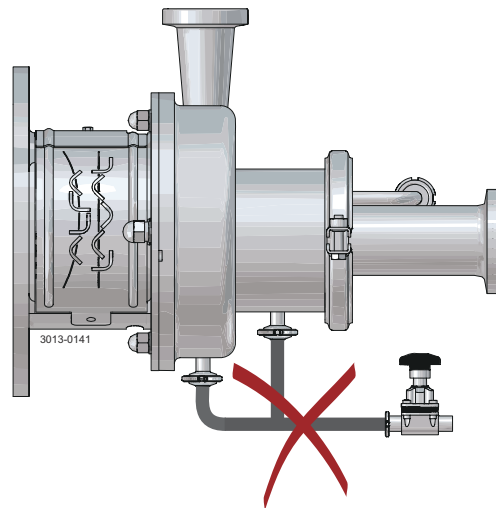
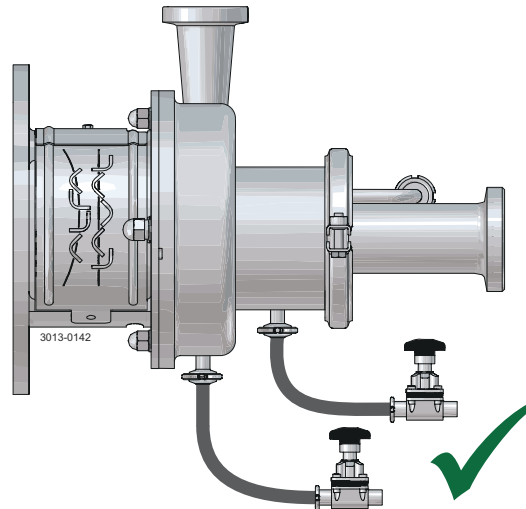

- 8 To ensure optimal function of the selfpriming capacity, LKH Prime must be installed in such a way that ensures liquid is in the pump on start-up e.g. with a swan neck design as illustrated.

NOTE

Max running time when releasing air only should not exceed 15 min.

	S _{min}	D _{min}
LKHex Prime-10 to -20:	200 mm	1.5 m X 2" pipe
LKHex Prime 40:	200 mm	1.5 m X 3" pipe or 2 m X 2" pipe

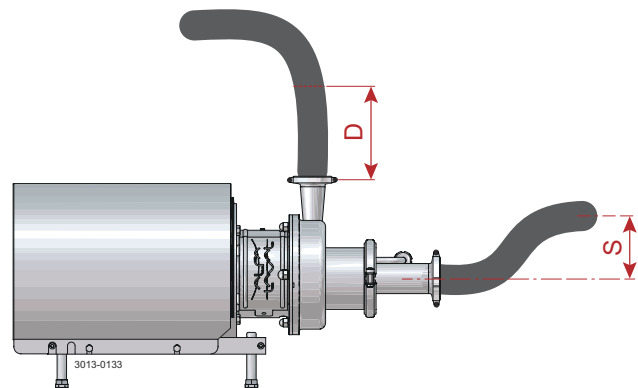

9 Installation guide lines

! NOTE

LKHex Prime is NOT a one-to-one replacement of the MR pump.

a) Suction considerations

Installation Ensure the suction line is designed so the Prime pump is liquid filled at start up, eg. swan neck. (see table in [step 8](#)).

Design suction line with slope down toward the pump to avoid air entrapments.

NPSH Ensure $NPSH_a > NPSH_r$ under all duty conditions including all temperatures.

Air inclusions Controlled start/stop of pump eg. Level Switch (LS)

- Do not start the LKHex Prime before tank bottom is liquid filled
- Stop the LKHex Prime during phase changes

b) General pump considerations

VFD Minimum speed for effective air evacuation is 2800 rpm

Air evacuation ability improves with higher speed (max. speed 3600 rpm)

Pump sizing The LKHex Prime must be sized for the specific duty point

c) Discharge considerations

Installation Ensure minimum length of vertical pipe after the LKH Prime (see table in [step 8](#))

Check valve Place check valve as far away from the pump as possible

Replace check valve with automated valve if possible

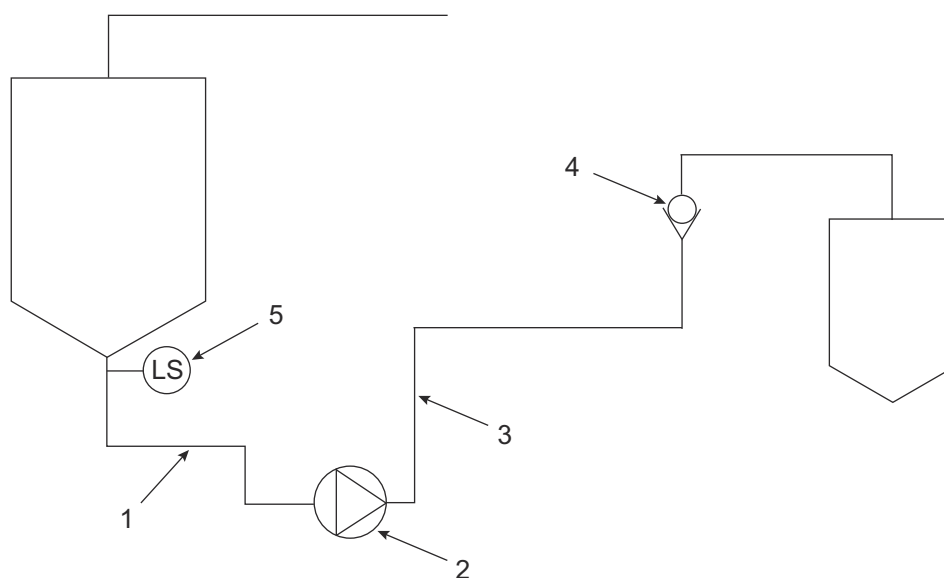

1. Suction line
2. LKH Prime Pump
3. Discharge line
4. Check valve
5. Level switch

WARNING

Always ensure the adaptor shield and motor fan guard are present and mounted correctly and allow no access to rotating parts before installing and starting the pump.

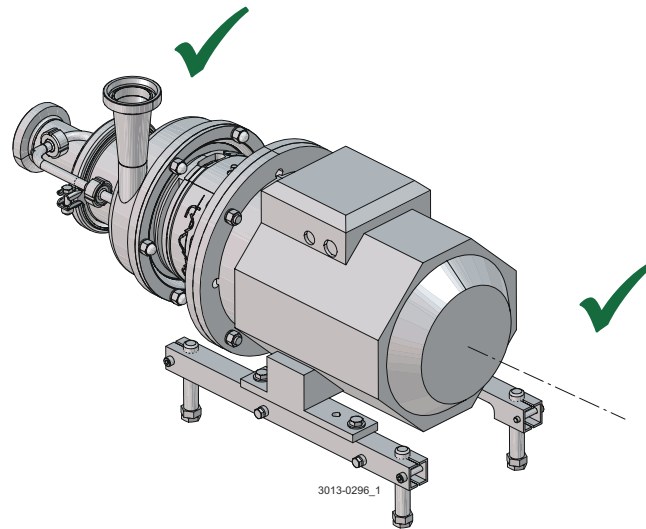

4.3 Pre-use Check

NOTE

Study the instructions carefully and pay special attention to the warnings!

Check the direction of rotation of the impeller before operation. See the indication label on the pump.

WARNING

Never start the pump if the impeller is fitted and the pump casing is removed.



CAUTION

Always remove the impeller before checking the direction of rotation.

1

- a) Remove adapter shields (22).
- b) Loosen unions and remove recirculation pipe (56).
- c) Remove clamp (57) and front cover (60).
- d) Remove air screw (58) with a spanner. Counter hold with a screwdriver. (See [Dismantling of Pump/Shaft Seals](#) on page 49).
- e) Unscrew cap nuts (24) and remove washers (24a) and pump casing (29).
- f) Remove impeller (37). If necessary, loosen the impeller by knocking gently on the impeller vanes. (See [Dismantling of Pump/Shaft Seals](#) on page 49).

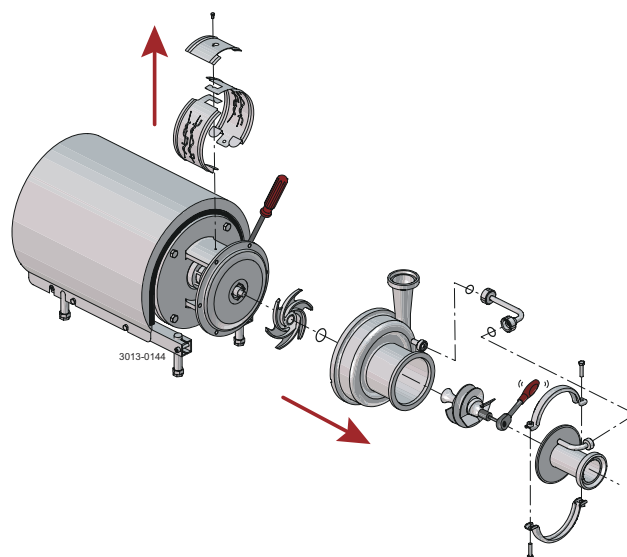

2

WARNING

Stay clear and ensure no one is near the shaft during test of rotation.

- a) Connect power supply.
- b) Start and stop the motor momentarily.
- c) Ensure that the direction of rotation of the stub shaft (7) is anticlockwise as viewed from the inlet side.
- d) Disconnect power supply safely.

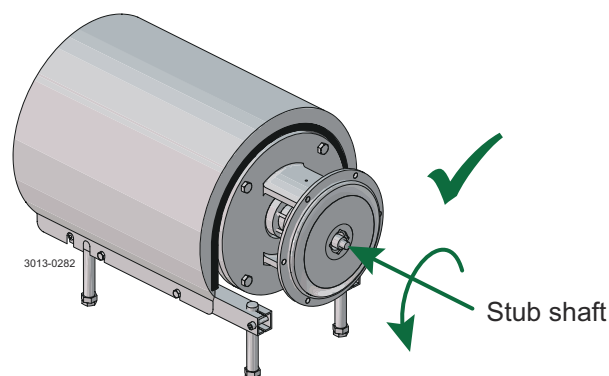

3 Fit and tighten the impeller (37).

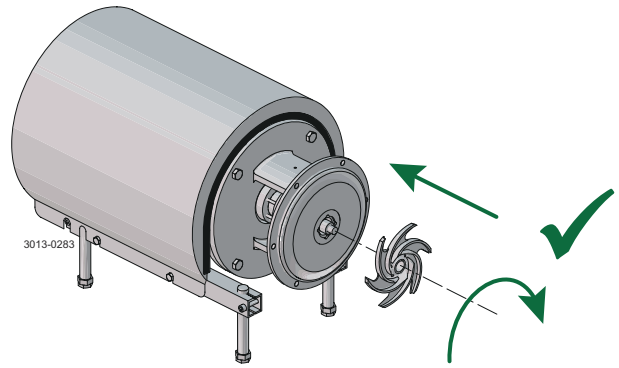

4 a) Fit pump casing (29) and washers (24a). Fit and tighten cap nuts (24) according to torque values in table in [Torque Specifications](#) on page 68.

b) Fit air screw (58) and tighten with a spanner (Torque: see table below).

Size	Tightening torque	
	Nm	lbf-ft
LKHex Prime-10 and -20:	20	15
LKHex Prime 40:	40	30

c) Fit front cover O-ring (59) and fit and align front cover (60). Fit clamp and tighten screws (57) gently.

d) Fit recirculation pipe (56), align front cover (60) and tighten unions.

e) Tighten clamp screws (57).

f) Fit the adaptor shields (22).

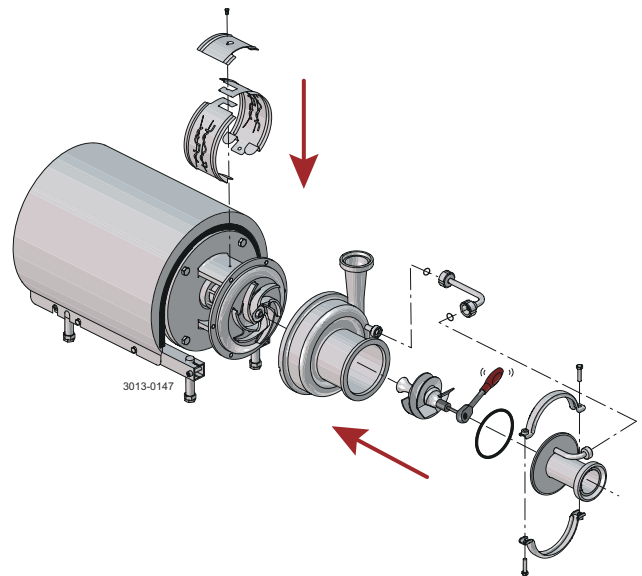

5 Operation

5.1 Important Check and Monitoring During Operation

NOTE

Read the instructions carefully and pay special attention to the warnings!

Daily checks

Shaft seal (SSS and DMS)

- If leakage from the shaft seal can lead to dangerous situations, daily visual inspection for leakage is recommended.
- If leakage is detected the risk should be evaluated and maintenance of the seal should be planned accordingly.

Other checks

Motor

- The bearing life is heavily dependent on the operating condition of the pump i.e. pressure, ambient temperature, motor load and pressure variations
- The motor should be serviced according to the guidelines in the motor instruction manual
- For information regarding motor relubrication, see [Relubrication Intervals](#) on page 68.

In order to detect motor bearing failure, the condition of the bearings must be monitored regularly.

It is recommended that the condition of the bearings is checked every 2000 hours of operation.

The condition of the bearings can be monitored in several ways eg. by means of vibration analysis (shock pulse measurements).

After checking the bearing condition, it must be evaluated if it is OK to continue or else maintenance of the bearings must be planned accordingly.

5.2 Operating Conditions

NOTE

Read the instructions carefully and pay special attention to the warnings!

General

Maximum ambient temperature:	-10 °C to +35 °C for T4, motor with shroud -10 °C to +40 °C for T4, motor without shroud -10 °C to +40 °C for T3
Maximum pump speed:	3600 rpm

Only Exdb and Exdbeb motors are designed to run with a variable speed drive (VDF).

If VFD is used, the motor should be oversized by 10 % with regards to power output.

Pump unit

Max. inlet pressure

LKHex Prime-10 to -40:	500 kPa / 5 bar / 72.5 psi
------------------------	----------------------------

Temperature, Class T4

Product temperature, NBR:	-10 °C to +80 °C / 14 °F to +176 °F
Product temperature, EPDM, FPM:	-10 °C to +100 °C / 14 °F to +212 °F
Ambient temperature, without shroud:	-20 °C to +40 °C / -4 °F to +104 °F
Ambient temperature, with shroud (<18.5kW):	-20 °C to +35 °C / -4 °F to +95 °F

Temperature, Class T3

Product temperature, NBR:	-10 °C to +80 °C / 14 °F to +176 °F
Product temperature, EPDM:	-10 °C to +130 °C / 14 °F to +266 °F
Product temperature, FPM:	-10 °C to +140 °C / 14 °F to +284 °F
Ambient temperature:	-20 °C to +40 °C / -4 °F to +104 °F

Viscosity

Maximum product viscosity:	800 cP
----------------------------	--------

Shaft seal

Single shaft seal (SSS)

The SSS is lubricated and cooled by the processed media. It is therefore important to pay special attention to the operating limits of the pump unit.

Double mechanical shaft seal (DMS)

The DMS is lubricated by the product media and/or the flush media and the buffer or barrier flushing principle can be used.

	Minimum pressure of buffer/ barrier fluid	Maximum pressure of buffer/ barrier fluid
Buffer fluid ¹ :	> 0 bar / psi	5 bar / 72.5 psi ²
Barrier fluid ¹ :	Pump inlet pressure plus 1 bar / 14.5 psi	5 bar / 72.5 psi

¹ Description of the two systems can be found in [Technical Data](#) on page 65

² Pressure must be lower than the pump inlet pressure. If the viscosity of the processed media is less than 1 cP when using silicon carbide vs. silicon carbide, ONLY barrier fluid is applicable.

Minimum flow rate of buffer/barrier fluid:	30 l/h / 8 gal/h
Minimum temperature of buffer/barrier fluid:	-10 °C / 14 °F
Maximum temperature of buffer/barrier fluid:	70 °C / 158 °F during operation ¹

¹ When the pump is not in operation the flush system can be sterilized up to 125°C (260°F)



For ATEX applications the pump should be stopped if the flush temperature measured at the outlet of the seal housing reaches 100 °C / 212 °F

5.3 Operation/Control

NOTE

Study the instructions carefully and pay special attention to the warnings!

Always read the *Technical Data* on page 65 thoroughly.

DANGER Explosion danger!

Never run the pump with both the suction side and the pressure side blocked.

See the warning label!

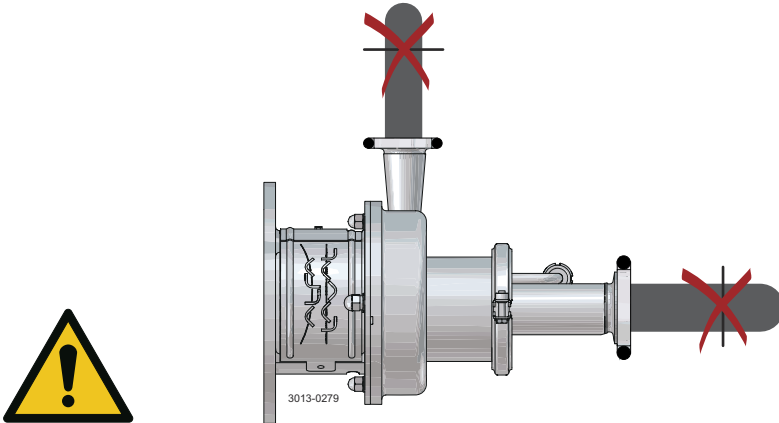

WARNING Burning risk!

Never touch the supplied product or the pipelines when processing hot liquids or sterilizing.

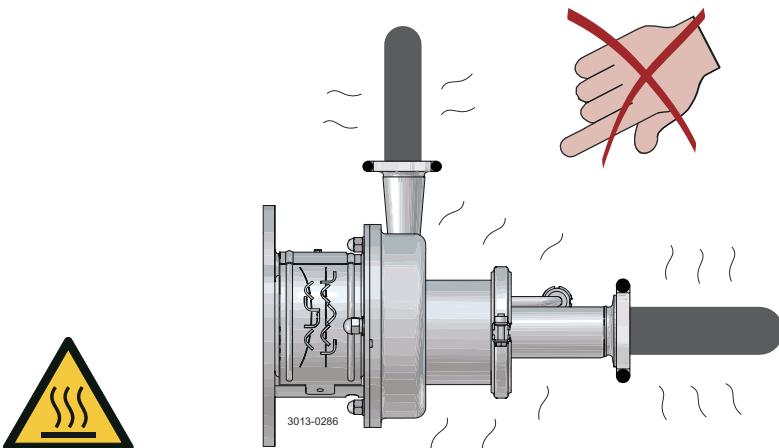

CAUTION

The shaft seal must not run dry.

Never throttle the inlet side.

*) **Do not allow to run dry**

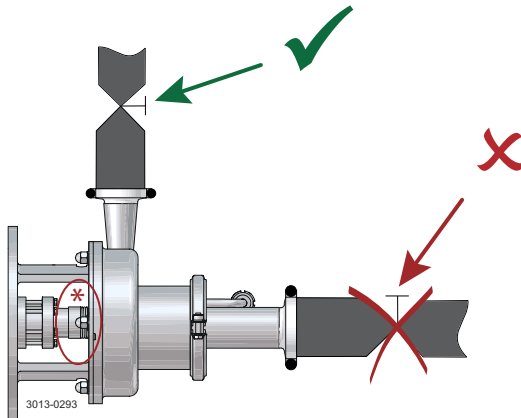

CAUTION

Alfa Laval cannot be held responsible for incorrect operation/control.

Double Mechanical Seal or Flushed Shaft Seal

1. Connect the inlet of the flushing liquid correctly.
2. Read instructions in *Operating Conditions* on page 40.
3. Regulate the water supply correctly.

O: Outlet

I: Inlet

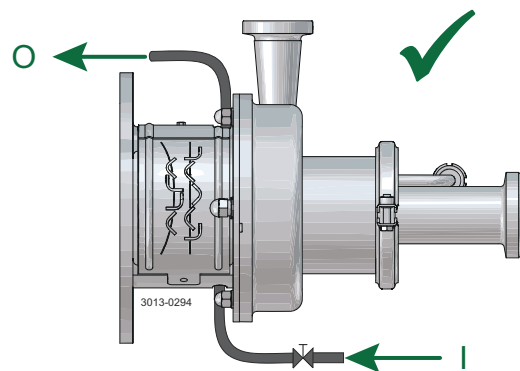

Control

Reduce the capacity and the power consumption by means of:

- *) Throttling the pressure side of the pump
- Reducing the impeller diameter
- Reducing the speed of the motor

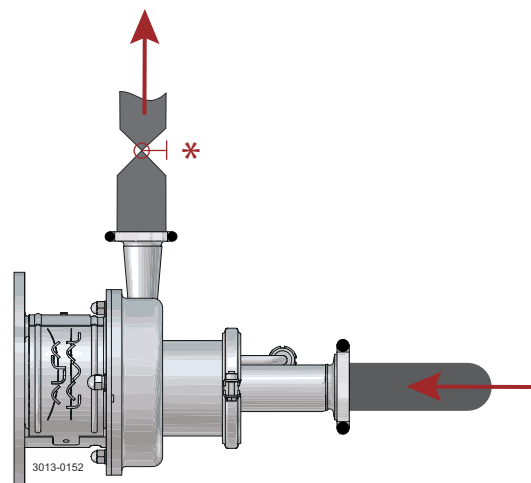

5.4 Troubleshooting

NOTE

Read the maintenance instructions carefully before replacing worn parts.

Problem	Cause/result	Remedy
Overloaded Motor.	Pumping of viscous liquids.	Larger motor or smaller impeller.
	Pumping of high density liquids.	
	Low outlet pressure (counter pressure).	Increase counter pressure (throttling).
	Lamination of precipitates from the liquid.	Frequent cleaning.
Cavitation: <ul style="list-style-type: none"> • Damage • Pressure reduction (sometimes to zero) • Increase in the noise level 	<ul style="list-style-type: none"> • Low inlet pressure • High liquid temperature 	<ul style="list-style-type: none"> • Increase the inlet pressure • Reduce the liquid temperature • Reduce the pressure drop before the pump • Reduce speed • $NPSH_A > NPSH_R$
Leaking shaft seal.	<ul style="list-style-type: none"> • Dry run • Incorrect rubber grade • Abrasive particles in the liquid 	Replace all wear parts. If necessary: <ul style="list-style-type: none"> • Change rubber grade • Change seal face material
	Incorrect SiC/SiC single seal used.	Change to SiC/SiC seal marked "LKH Prime".
Leaking O-ring seals.	<ul style="list-style-type: none"> • Incorrect rubber grade • Aged O-ring 	Change rubber grade. Change O-rings
No/little air release.	See possible causes in the Installation guide lines.	Follow recommendations in the Installation guide lines.

5.5 Recommended Cleaning

⚠ WARNING Risk of burns!

Never touch the supplied product or the pipelines when sterilizing.



⚠ CAUTION

Always handle lye and acid with great care.



! NOTE

The supplied product is designed for cleaning in place (CIP).

NaOH = Caustic soda.

HNO₃ = Nitric acid.

The cleaning agents must be stored/disposed of in accordance with current regulations/directives.

Examples of cleaning agents

! NOTE

Use clean water free from chlorides.

Metric System

1. 1% by weight NaOH at 70°C

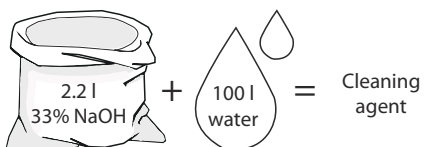
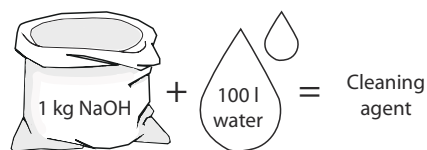

2. 0.5% by weight HNO₃ at 70°C

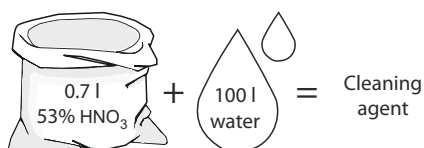

Imperial System

1. 1% by weight NaOH at 158°F

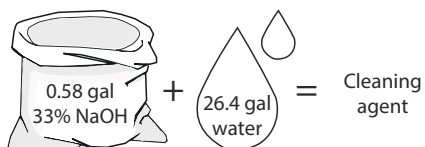
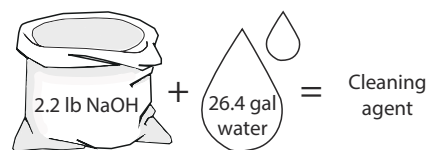

2. 0.5% by weight HNO₃ at 158°F

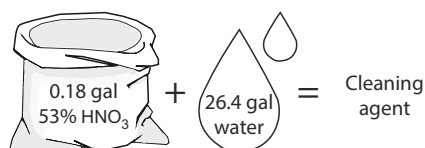

1. Avoid excessive concentration of the cleaning agent ⇒ **Dose gradually!**
2. Adjust the cleaning flow to the process
Milk sterilization/viscous liquids ⇒ Increase the cleaning flow!

**CAUTION**

Always rinse well with clean water after the cleaning.

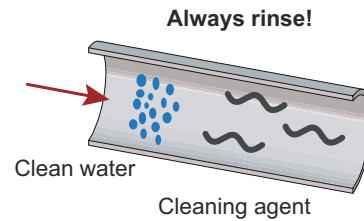

5.5.1 Cleaning Information

**NOTE**

If pumps are sterilised using steam, standard 3A requires the process system to be designed to automatically shut down if the product pressure in the system becomes less than of the atmosphere and it cannot be started until the system is re-sterilised.

The LKH pump range has been designed for Clean in Place (CIP) operation with both 3A and EHEDG certification. However, due to variations in pumped product, system design, cleanliness requirements and chemicals used we recommend that users develop suitable CIP processes during commissioning on normal operation conditions and products and verify these meet the required levels of cleanliness ensuring a minimum flow velocity of 1.5 m/s in the pump inlet.

To ensure optimum drainability of the pumpcase we recommend the pump is specified with 270° outlet position (horizontal bottom) or a drainvalve.

6 Maintenance

6.1 General Maintenance

NOTE

Maintain the pump carefully.

Study the instructions carefully and pay special attention to the warnings!

For motor maintenance, see motor instruction manual.

Always read the *Technical Data* on page 65 thoroughly.

Always keep spare shaft seals and rubber seals in stock.

Check the pump for smooth operation after service.

All scrap must be stored/disposed of in accordance with current regulations and directives.

If the pump is supplied with FEP O-rings. Alfa Laval recommends that the casing O-ring is replaced during pump maintenance.

DANGER

Never service the pump if pressurised.

*Atmospheric pressure required!

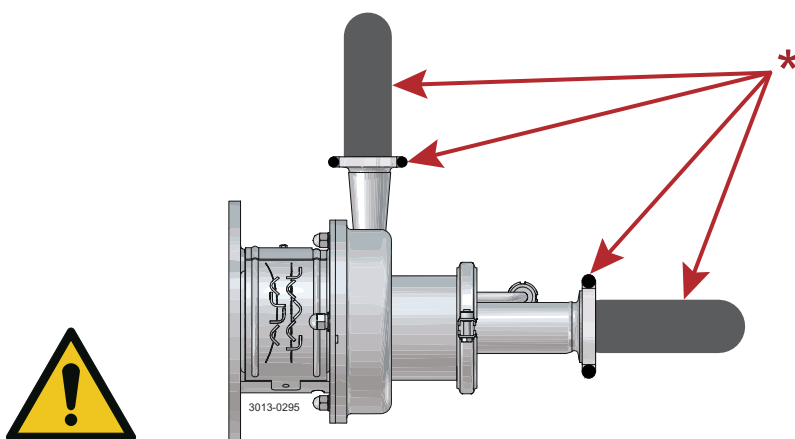

WARNING

Burning risk!

Never service the pump when it is hot.

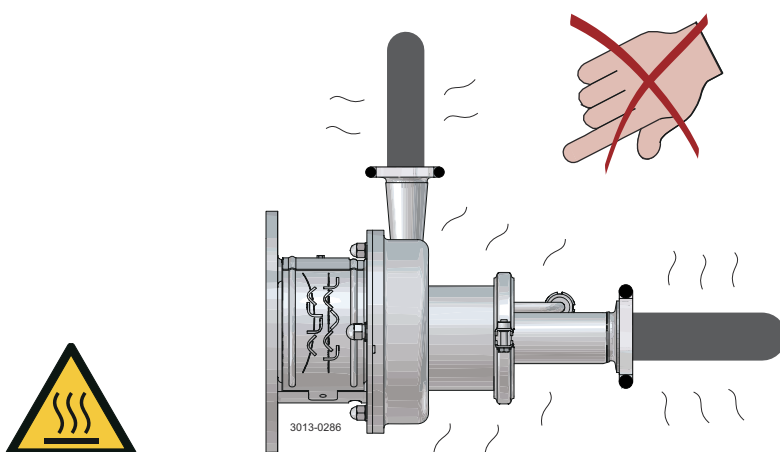



Always disconnect the power supply when servicing the pump.

Fit the electrical connections correctly if they have been removed from the motor during service.



	Shaft seal	Rubber seals	Motor bearings
Preventive maintenance	Replace after 12 months: (one-shift) Complete shaft seal.	Replace when replacing the shaft seal.	
Maintenance after leakage (leakage normally starts slowly)	Replace at the end of the day: Complete shaft seal.	Replace when replacing the shaft seal.	
Planned maintenance	<ul style="list-style-type: none"> Regular inspection for leakage and smooth operation Keep a record of the pump Use the statistics for planning of inspections Replace after leakage: Complete shaft seal.	Replace when replacing the shaft seal.	Yearly inspection is recommended <ul style="list-style-type: none"> Replace complete bearing if worn Ensure that the bearing is axially locked (See motor instructions)
Lubrication	Before fitting: Lubricate the O-rings with silicone grease or silicone oil.	Before fitting: Lubricate with silicone grease or silicone oil.	See information on motor name plate.

Pre-use Check

See [Pre-use Check](#) on page 37.

6.2 Dismantling of Pump/Shaft Seals

NOTE

Study the instructions carefully and pay special attention to the warnings!

The items refer to *Parts Lists and Exploded Views* on page 73.

- 1 Remove screw (23) and safety guard (22).

Double mechanical shaft seal:

Remove tubes at top and bottom from connection in seal housing (40a).

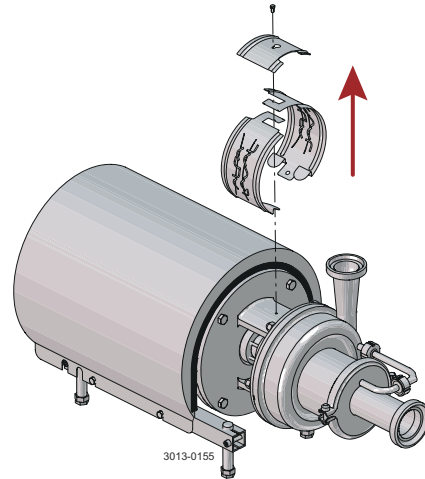

- 2
 - a) Loosen unions and remove recirculation pipe (56).
 - b) Remove clamp (57) and front cover (60).

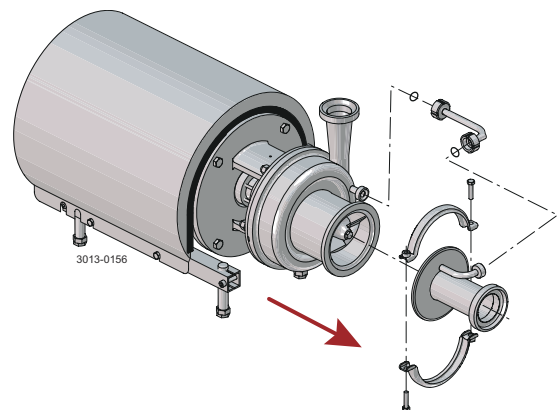

- 3
 - a) Remove air screw (58) with a spanner. Counter hold with a screwdriver on pump shaft (7).
 - b) Unscrew cap nuts (24). Remove washers (24a) and pump casing (29).

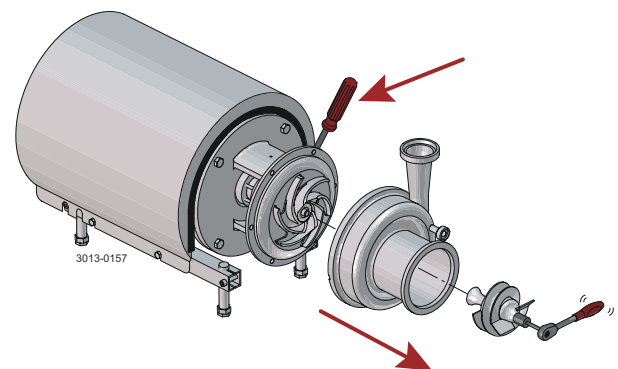

- 4**
- a) Remove impeller (37). If necessary, loosen the impeller by knocking gently on the impeller vanes.
 - b) Remove the O-ring (38) from the impeller
- * Counterhold with a screwdriver!

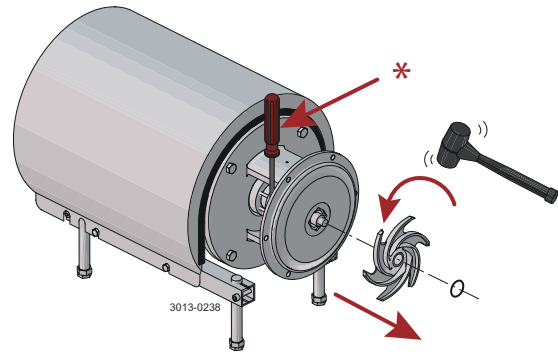

- 5**
- a) Pull off the O-ring (26) from back plate (25).
 - b) Unscrew nuts (20) and remove washers (21) and the back plate. (25).

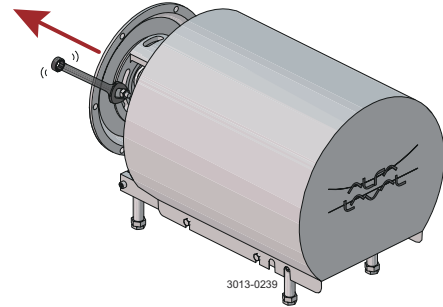

- 6**
- a) Remove the stationary seal ring (11).
 - b) Remove the O-ring (12) from back plate (25).
- *) Use the tool supplied. Left hand thread!

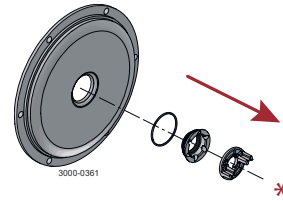

- 7 In the event the stationary seal ring (11) is difficult to untread from the backplate (25), the extra seal tool supplied can be used to fixate the seal tool in the stationary seal ring (11).

a) The seal tool is fitted into the stationary seal ring (11).

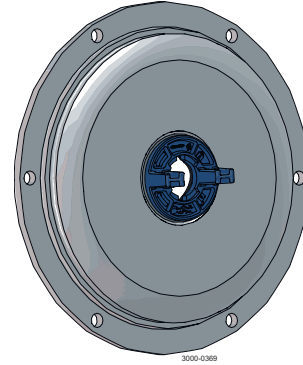

b) The extra seal tool is assembled from rear side of the backplate (25) and turned to either side for locking the seal tool into the stationary seal ring (11).

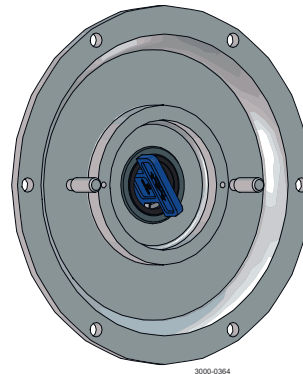

c) Now the seal tool can be untreaded without losing grip of the stationary shaft seal.

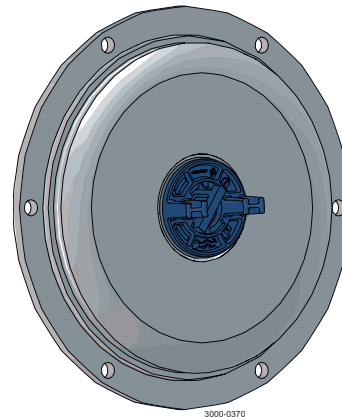

8 **Double mechanical shaft seal:**

- a) Remove screws (41) and seal housing (40a).
- b) Remove rotating seal rings (14) and drive ring (52) from spring (13).
- c) Remove O-rings (15) from rotating seal rings (14).

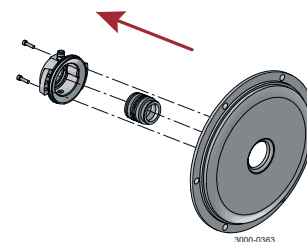

9 Double mechanical shaft seal:

- a) Remove stationary seal ring (51) from seal housing (40a).
- b) Remove O-ring (50) from stationary seal ring (51).
- c) Remove O-ring (44) from seal housing (40a).

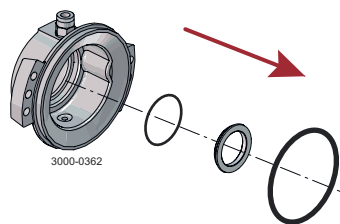

- 10** a) Remove the complete shaft seal from stub shaft (7).
- b) Remove spring (13) and rotating seal ring (14) from the drive ring (10).

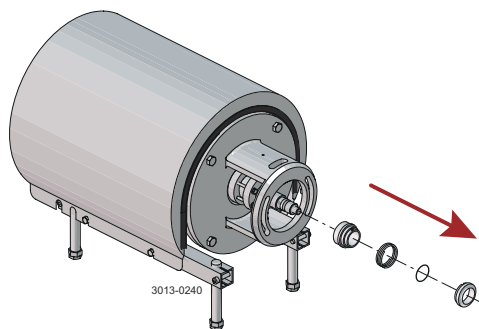

6.3 Assembly of Pump/Single Shaft Seal

NOTE

Study the instructions carefully and pay special attention to the warnings!

The items refer to *Parts Lists and Exploded Views* on page 73.

If fitting SiC/SiC single seal, the static seal in backplate must be marked "LKH Prime".

1 Remove spring (13).

NOTE

Make sure that O-ring (15) has maximum clearance from the sealing surface.

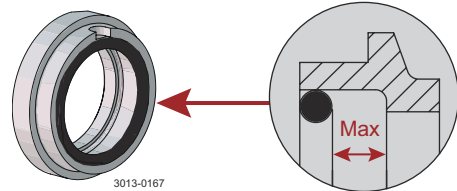

2 a) Refit spring (13) on rotating seal ring (14).

b) Fit the spring and the rotating seal ring on drive ring (10).

CAUTION

Ensure that the driver on the drive ring enters the notch in the rotating seal ring.

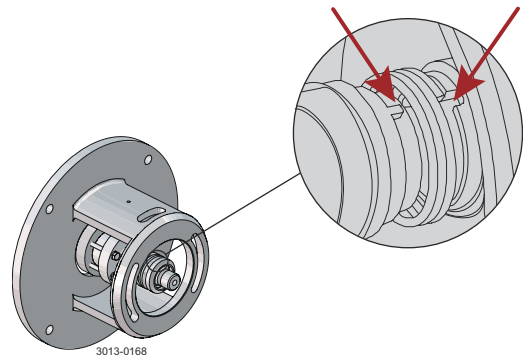

3 Fit the complete shaft seal onto the stub shaft (7)

CAUTION

Make sure that Connex pin (8) on the stub shaft enters the notch in drive ring (10).

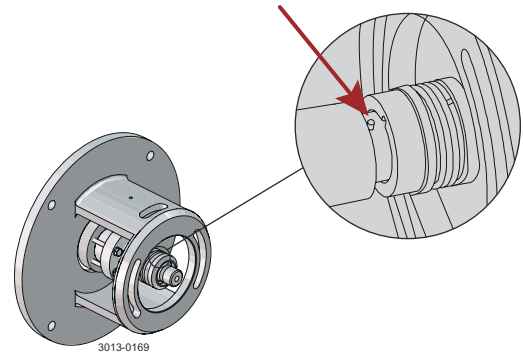

- 4
- a) Fit O-ring (12) on stationary seal ring (11) and lubricate.
 - b) Screw the stationary seal ring into back plate (25).

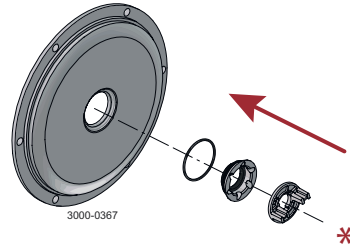

CAUTION

Only tighten by hand to avoid deforming the stationary seal ring.
(Max. 7 Nm / 5 lbf-ft)

NOTE

If fitting SiC/SiC single seal, the static seal in backplate must be marked "LKH Prime".

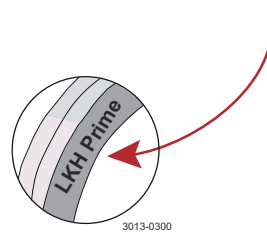

*) Use the tool supplied. Left hand thread!

- 5
- a) Clean the sealing surfaces with contact cleaner before fitting back plate (25).
 - b) Carefully guide the back plate onto adaptor (16).
 - c) Fit washers (21) and nuts (20) and tighten according to [Torque Specifications](#) on page 68.

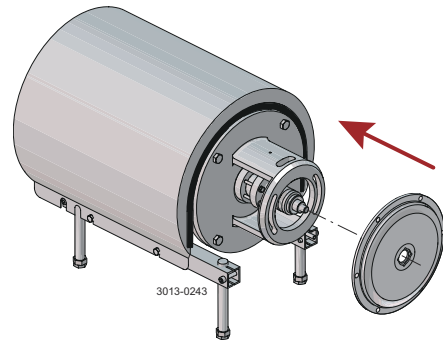

- 6
- Lubricate O-ring (26) and slide it onto back plate (25).

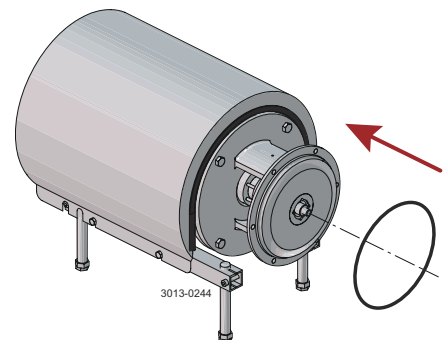

- 7**
- Lubricate O-ring (38) and fit it in impeller (37).
 - Lubricate impeller hub with silicone grease or oil.
 - Screw the impeller onto stub shaft (7).

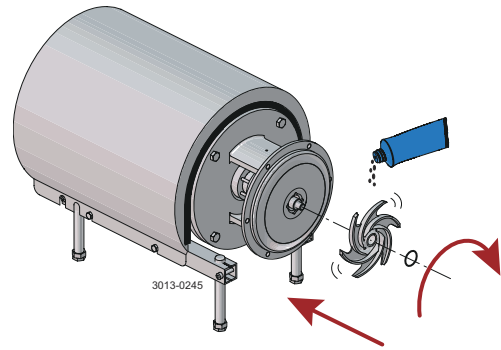

- 8**
- Fit pump casing (29), washers (24a) and cap nuts (24).
 - Adjust pump casing (29) to correct position.
 - Tighten nuts (20) for back plate (25) and tighten cap nuts (24), according to *Torque Specifications* on page 68.
 - Fit air screw (58) and tighten with a spanner (Torque: see table below).

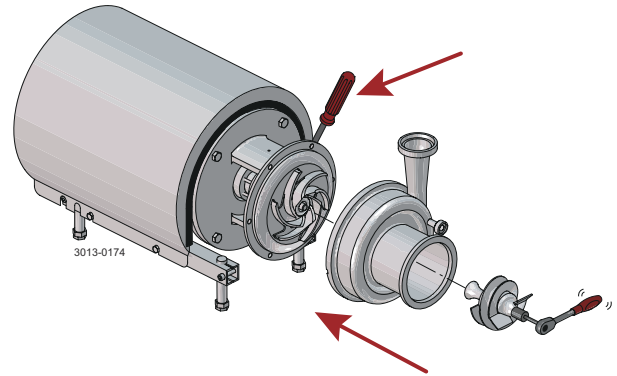

Size	Tightening torque	
	Nm	lbf-ft
LKHex Prime-10 and -20:	20	15
LKHex Prime 40:	40	30

- 9**
- Fit front cover O-ring (59) and fit and align front cover (60).
 - Fit clamp and tighten screws (57) gently.
 - Fit recirculation pipe (56), align front cover (60) and tighten unions.
 - Tighten clamp screws (57).

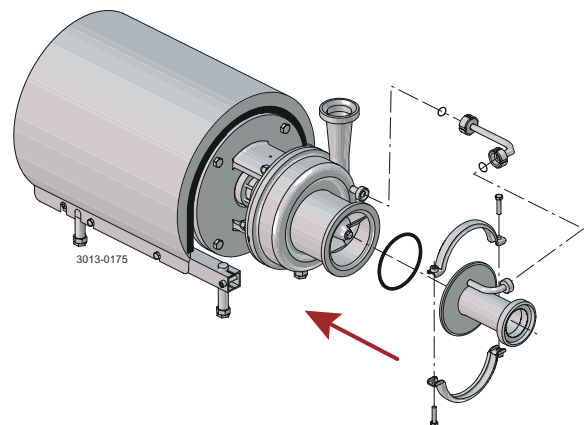

- 10 Fit safety guards (22) and screw (23) and tighten.



If pump is not supplied with flush connections, the holes in the adaptor must be covered by the guard.

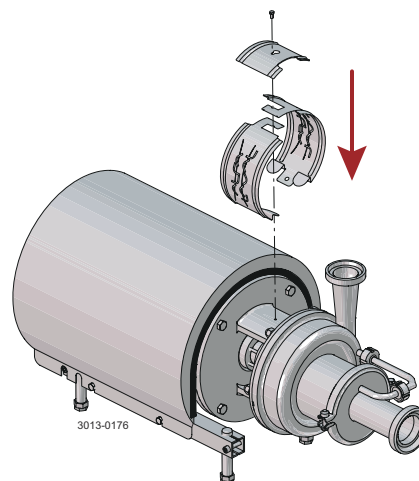

6.4 Assembly of Pump/Double Mechanical Shaft Seal

NOTE

Study the instructions carefully and pay special attention to the warnings!

The items refer to *Parts Lists and Exploded Views* on page 73.

1

- a) Fit O-rings (15) in rotating seal rings (14).

NOTE

Make sure that O-ring (15) has maximum clearance from the sealing surface.

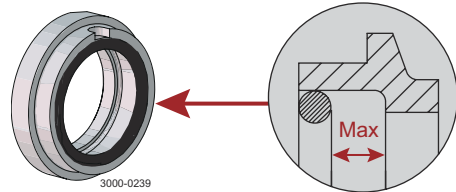

- b) Fit spring (13) on one of the rotating seal rings (14) and place the drive ring (52) in rotating seal ring.

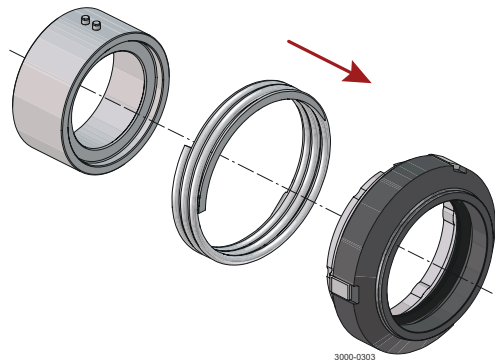

2

- a) Fit O-ring (12) on stationary seal ring (11) and lubricate.
- b) Screw the stationary seal ring into back plate (25).

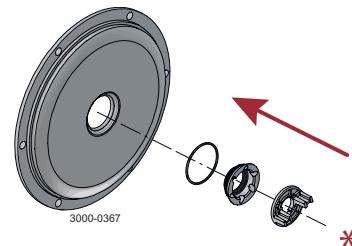

CAUTION

Only tighten by hand to avoid deforming the stationary seal ring.

(Max. 7 Nm / 5 lbf-ft)

*) Use the tool supplied. Left hand thread!

NOTE

If fitting SiC/SiC single seal, the static seal in backplate must be marked "LKH Prime".

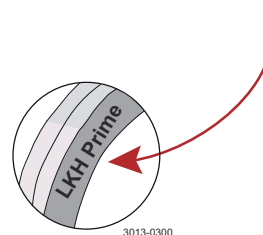

- 3
- a) Fit the second rotating seal ring (14) on the other end of the spring.
 - b) Clean the sealing surfaces with contact cleaner.
 - c) Place the parts on the stationary seal ring fitted in the back plate (25).

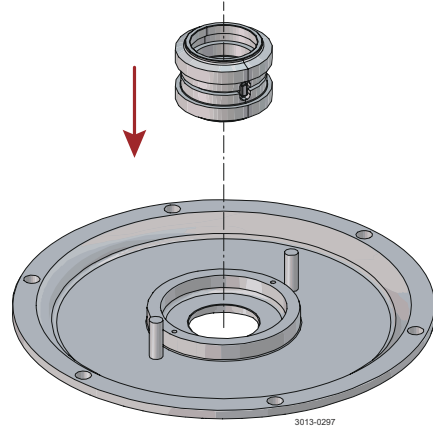

NOTE

Ensure that both drive pin(s) on the drive ring enter the notches in the rotating seal rings.

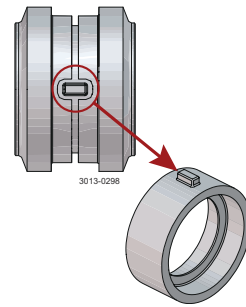

- 4
- a) Lubricate O-ring (44) and slide onto seal housing (40a).
 - b) Lubricate O-ring (50) and fit on stationary seal ring (51) and fit this in the seal housing.

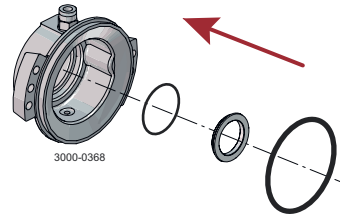

- 5
- a) Clean the sealing surfaces with contact cleaner.
 - b) Fit seal housing (40a) on the back plate (25) and tighten screws (41).

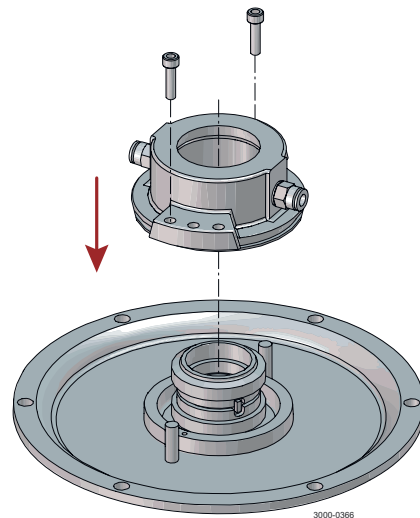

- 6**
- To enable fitting of back plate (25) with the shaft seal, remove Connex pin (8) from stub shaft (7), if fitted.
 - Carefully guide the back plate onto adaptor (16).
 - Fit washers (21) and nuts (20) and tighten according to *Torque Specifications* on page 68.

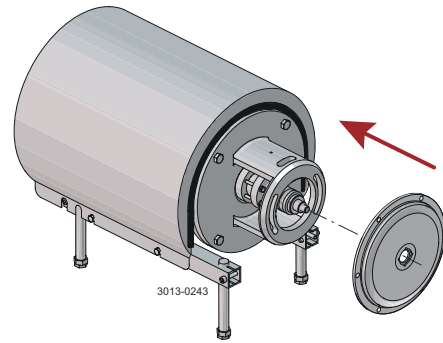

- 7** Lubricate O-ring (26) and slide it onto back plate (25).

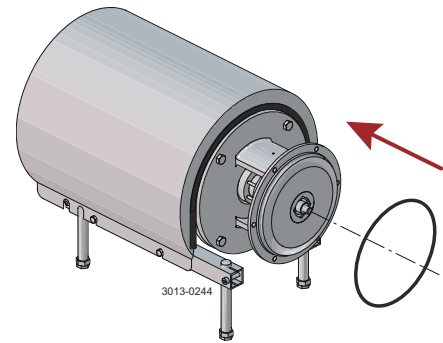

- 8**
- Lubricate O-ring (38) and fit it in impeller (37), if impeller screw is used.
 - Lubricate the impeller hub with silicone grease or oil.
 - Screw impeller (37) onto stub shaft (7).

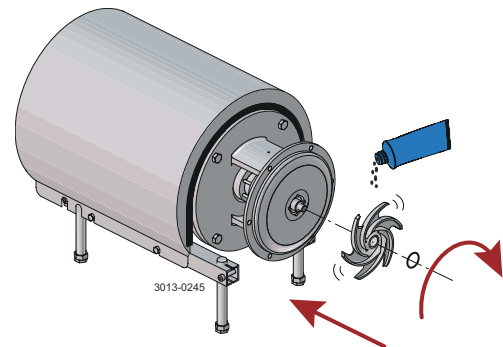

- 9**
- Fit pump casing (29) and washers (24a). Fit and tighten cap nuts (24) according to torque values in chapter 6 Technical data.
 - Adjust pump casing (29) to correct position.
 - Tighten nuts (20) for back plate (25).
 - Fit air screw (58) and tighten with a spanner (Torque: see table below).

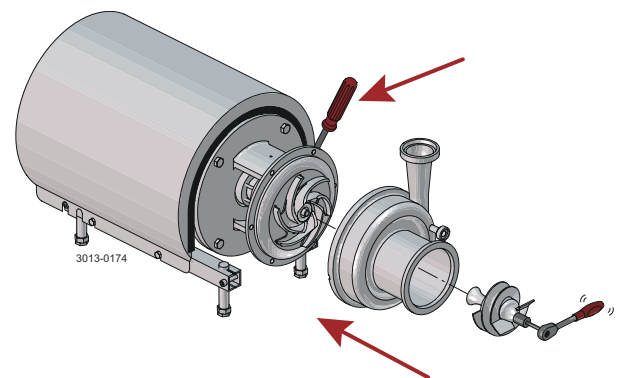

Size	Tightening torque	
	Nm	lbf-ft
LKHex Prime-10 and -20:	20	15
LKHex Prime 40:	40	30

- 10**
- Fit front cover O-ring (59) and fit and align front cover (60).
 - Fit clamp and tighten screws (57) gently.
 - Fit recirculation pipe (56), align front cover (60) and tighten unions.
 - Tighten clamp screws (57).

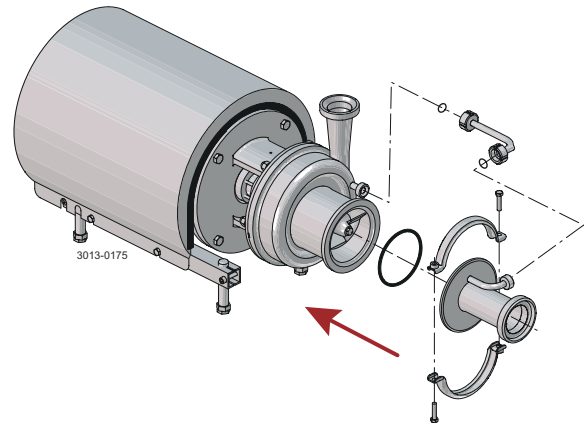

- 11**
- Fit tubes in connection at top and bottom in seal housing (40a)
 - Fit safety guard (22) and screw (23) and tighten.

If pump is not supplied with flush connections, the holes in the adapter will be covered by the guard.

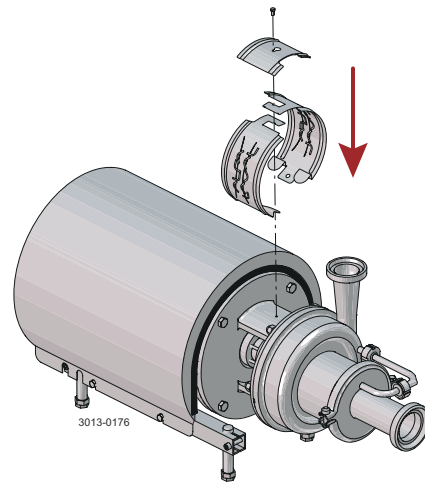

6.5 Adjustment of Shaft

NOTE

Study the instructions carefully and pay special attention to the warnings!

The items refer to *Parts Lists and Exploded Views* on page 73.

For securing the best fixture to the motor shaft ensure the following:

- Conical surfaces on the pump shaft and compression rings are applied with grease
- No grease on the motor shaft
- No grease on the inside diameter of the pump shaft
- Screws for the compression rings are applied with grease

- 1
 - a) Remove shroud (2).
 - b) Unscrew nuts (18) and remove washers (19), screws (17) and adapter (16).

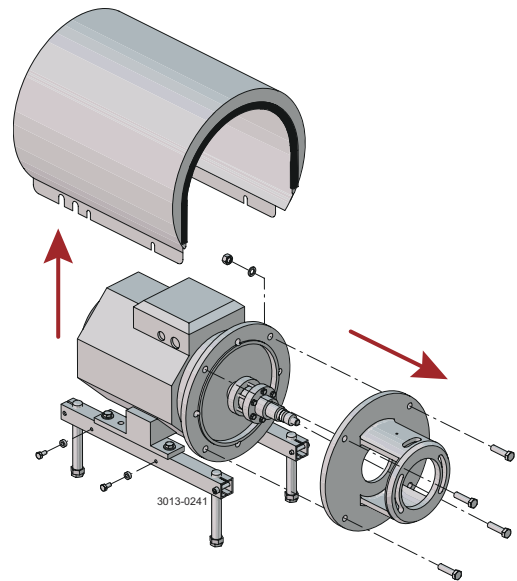

- 2
 - a) Loosen screws (6).
 - b) Pull off stub shaft (7) together with compression rings (5a, 5b).

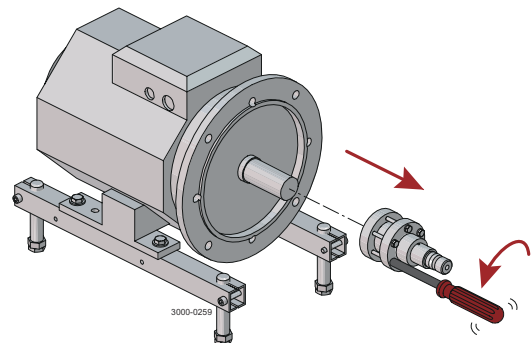

- 3
- a) Push stub shaft (7) together with compression rings (5a, 5b) onto the motor shaft.
 - b) Check that the clearance between the end of the stub shaft and the motor flange is 10-20 mm / 0.39-0.78".

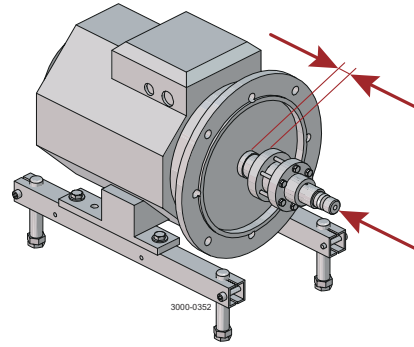

- 4
- a) Tighten screws (6) lightly and evenly.
 - b) Ensure that stub shaft (7) can be moved on the motor shaft.

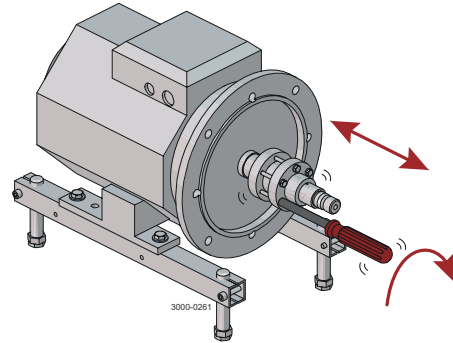

- 5
- a) Fit shroud (2).
 - b) Fit adapter (16), screws (17), washers (19) and nuts (18), and tighten.

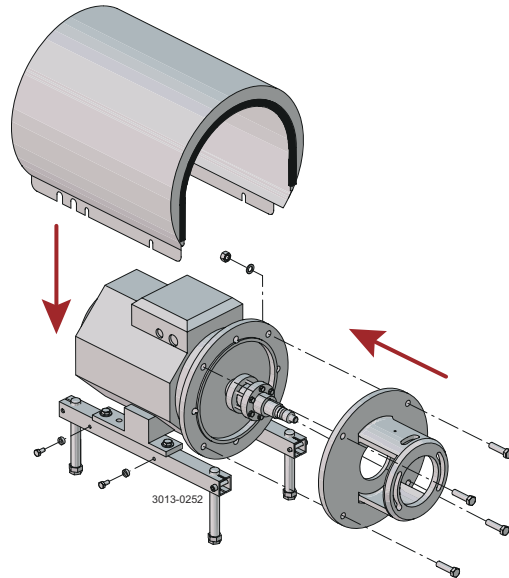

- 6
- a) **Double mechanical shaft seal:**
Fit drive ring (52) on stub shaft (7).
 - b) Fit back plate (25), washers (21) and nuts (20) and tighten according to [Torque Specifications](#) on page 68.

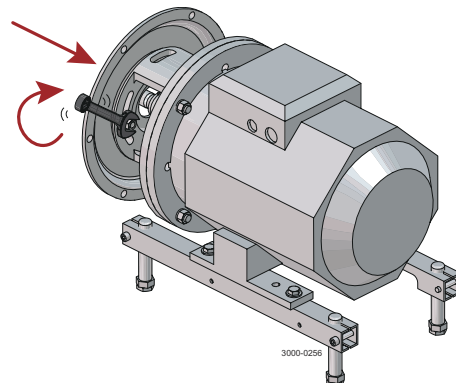

- 7
- Fit impeller (37) on stub shaft (7).
 - Ensure that the clearance between the impeller and back plate (25) is correct:

LKHex Prime-10, and -20: 0.5 mm / 0.02"

LKHex Prime-40: 1.0 mm / 0.039"
 - Tighten screws (6) evenly until the stub shaft (7) cannot move on the motor shaft.

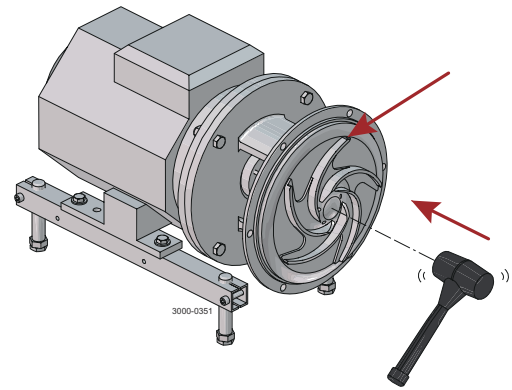

NOTE

The clearance can be adjusted by knocking gently with a plastic hammer.

Please note LKHex-40 impeller is marked with "1.0 mm GAP".

If NOT marked with "1.0 mm GAP" the clearance shall be 0.5 mm.

- 8
- Remove impeller (37), back plate (25) and drive ring (52).
 - Tighten screws (6) evenly to 15 Nm (11 lbf-ft).
 - Pump is assembled according to [Assembly of Pump/Single Shaft Seal](#) on page 53 or [Assembly of Pump/Double Mechanical Shaft Seal](#) on page 57.

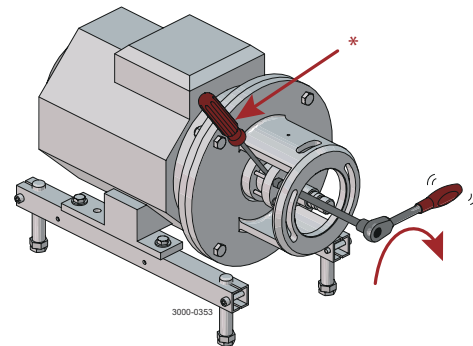

NOTE

Tighten screws diagonally.

This page is intentionally left blank.

7 Technical Data

NOTE

Technical data must be observed during installation, operation and maintenance.
All personnel should be informed about the technical data.

7.1 Technical Data

The LKH pump is a highly efficient and economical centrifugal pump, which meets the requirements of sanitary and gentle product treatment and chemical resistance.

LKH Prime is available in the following sizes LKHex Prime-10, -20 and -40.

Materials

Product wetted steel parts:	W. 1.4404 / 316L
Other steel parts:	Stainless steel
Product wetted elastomers:	EPDM (standard) or Nitrile (NBR) and fluorinated rubber (FPM)
Other elastomers:	EPDM
Stationary seal ring:	Acid-resistant steel with sealing surface of silicon carbide
Rotating seal ring:	Carbon (standard) or silicon carbide

Motor

IEC: Foot-flanged ATEX approved motor according to the IEC metric standard, 2 poles = 3000/3600 rpm. at 50/60 Hz.

Motor sizes

50 Hz:	1.5 - 45 kW
60 Hz:	1.8 - 45 kW

Min/max motor speed

Air evacuation:	2800-3600 rpm
Pumping product (no air):	900-3600 rpm

7.2 Operation Data

Max. inlet pressure

LKHex Prime-10 to -40: 500 kPa / 5 bar / 72.5 psi

Air release time

LKHex Prime-10 to -40: Max. 15 min.

Temperature, Class T4

Product temperature, NBR: -10 °C to +80 °C / 14 °F to +176 °F

Product temperature, EPDM, FPM: -10 °C to +100 °C / 14 °F to +212 °F

Ambient temperature, without shroud: -20 °C to +40 °C / -4 °F to +104 °F

Ambient temperature, with shroud (<18.5kW): -20 °C to +35 °C / -4 °F to +95 °F

Temperature, Class T3

Product temperature, NBR: -10 °C to +80 °C / 14 °F to +176 °F

Product temperature, EPDM: -10 °C to +130 °C / 14 °F to +266 °F

Product temperature, FPM: -10 °C to +140 °C / 14 °F to +284 °F

Ambient temperature: -20 °C to +40 °C / -4 °F to +104 °F

Viscosity

Maximum product viscosity: 800 cP

Double Mechanical Shaft Seal

Water pressure inlet: Max. 500 kPa / 72.5 psi (5 bar)

Water consumption: 0.5 l/min / 8 USGPH

	Minimum pressure of buffer/ barrier fluid	Maximum pressure of buffer/ barrier fluid
Buffer fluid:	> 0 bar / psi	5 bar / 72.5 psi
Barrier fluid:	Pump inlet pressure plus 1 bar / 14.5 psi	5 bar / 72.5 psi

Connections for Double Mechanical Shaft Seal

LKHex Prime-10 to -40: 1/8"

7.3 Technical Information and Description of Mechanical Shaft Seals

General Considerations Regarding Mechanical Shaft Seals

The basic working principle of a mechanical seal is that the seal faces are cooled and lubricated by the process media or the flush media.

If the seal faces are not cooled and lubricated, the temperature of the faces will increase to be above the temperature at normal running conditions. This is referred to as “dry running”.

Dry running will shorten the lifetime of the seal and eventually cause the seal to fail. Dry running is not allowed in ATEX applications.

Due to this working principle, there will be a small controlled leakage from the seal during normal operation. This leakage will increase if seal failure occurs. When a seal is failing the degree of leakage can go from a drop leakage to a flush leakage depending on the type of failure.



NOTE

The risk of leakage from a failing seal must be considered if pumping products where leakage can lead to hazardous situations.

Single mechanical shaft seal (SSS)

The SSS is cooled and lubricated by the process media.

The process media must always be present during operation to avoid dry running.

The Critical temperature range and the minimum flow rate of the process media are stated in [Special Conditions for Safe Use](#) on page 19.

Double mechanical shaft seal (DMS)

If continuous presence of process media cannot be guaranteed or leakage of the process media is unacceptable, a DMS should be applied.

The DMS is cooled and lubricated by the process media and/or the flush media.

Flush media must always be present during operation of the pump to avoid dry running.

Requirements for minimum flows and max temperatures of the flush media are stated in [Special Conditions for Safe Use](#) on page 19.

There are two basic flush principles for DMS:

- Buffer fluid system having a pressure lower than the pumped media. This principle will flush away possible solidifications and residues from the primary seal. It is the product media which lubricates the primary seal faces and the flush media lubricating the secondary seal faces.
- Barrier fluid system having a pressure of minimum 1bar above the pump inlet pressure. This principle will cool and lubricate both the primary and secondary seal. The barrier principle can be used in many applications but should be used if the seal configuration is SiC/SiC and the process media viscosity is less than 1cP.

7.4 Relubrication Intervals

For recommended general maintenance follow the recommendations in the motor instruction manual.

NOTE

Always lubricate according to motor manufactures recommended procedures.

Always locate and remove grease vent plugs, if provided, prior to adding grease.

Always check motor nameplate for grease type and lubrication intervals.

For further information contact your local Alfa Laval Technical Support.

CAUTION

Only use the grease type specified on the motor name plate.

7.5 Torque Specifications

NOTE

The table below specifies the tightening torques for the screws, bolts and nuts in this pump.

Always use the torques specified below if no other values are shown. This may affect personal safety.

Size	Tightening torque	
	Nm	lbf-ft
M8	20	15
M10	40	30
M12	67	49
M14	110	81

7.6 Weight (kg)

NOTE

Weight can vary depending of configuration. Weight is only to be seen as a reference value during handling, transporting and packaging.

Pump Type: LKHex Prime

Size	Frame size					
	90	100	112	132	160	180
10	65	80	85	110		
20		80	85	110	180	
40				120	185	220

7.7 Noise emission

Pump type	Sound pressure level (dBA)
LKHex Prime 10	69
LKHex Prime 20	74
LKHex Prime 40	77

The noise measurements are carried out using the original motor and shroud, at the approximate Best Efficiency Point (BEP) with water at ambient temperature and at 50Hz.

Very often, the noise level generated by the flow through the process system (e.g. valves, pipes, tanks etc.) is much higher than that generated by the pump itself. Therefore, it is important to consider the noise level from the total system and take the necessary precautions with regard to personal safety if required.

8 Spare Parts

For every delivered Alfa Laval Product, a spare part list is available.

This spare part list contains a range of the most common wear parts for the machinery. If any component not mentioned is required, please contact your local Alfa Laval representative for availability.

You can find our spare part catalogue at <https://hygienicfluidhandling-catalogue.alfalaval.com>.

Always use Alfa Laval genuine spare parts. The warranty of Alfa Laval products is dependent on use of Alfa Laval genuine spare parts.

8.1 Ordering Spare Parts

When ordering spare parts, please always state:

1. Serial number (if available)
2. Item number/spare part number (if available)
3. Capacity or other relevant identification

8.2 Alfa Laval Service

Alfa Laval is represented in all larger countries of the world.

Do not hesitate to contact your local Alfa Laval representative, with any questions or requirement of spare parts for Alfa Laval equipment.

8.3 Warranty - Definition



The rules of Intended use are absolute. Use of the supplied Alfa Laval product is allowed only when in compliance with the technical data supplied with the Intended use.

Differing utilisation, other than agreed with Alfa Laval Kolding A/S, exclude any liability and warranty.

No modification or alteration of the supplied Alfa Laval product is allowed, unless explicit permission is granted by Alfa Laval Kolding A/S.



Liability and warranty are excluded:

- If advice and instruction of operating instructions are ignored
- For incorrect operation or for insufficient maintenance of the supplied Alfa Laval product
- For any kind of change of function of the supplied Alfa Laval product without prior written agreement by Alfa Laval Kolding A/S
- If supplied Alfa Laval product is modified by non-authorized persons
- If using the supplied Alfa Laval product without attention of appropriate safety regulations, (see [Safety](#) on page 9)
- If protection equipment is not used and vessel process / ancillary equipment is not brought to a standstill
- If the supplied Alfa Laval product and ancillary parts are not properly maintained (to be executed in intervals and including fitting of prescribed replacement parts)

When exchanging parts, only original replacement parts, released from the manufacturer, must be used.

9 Parts Lists and Exploded Views

9.1 Sectional drawing and details of the LKHex Prime, Sanitary version

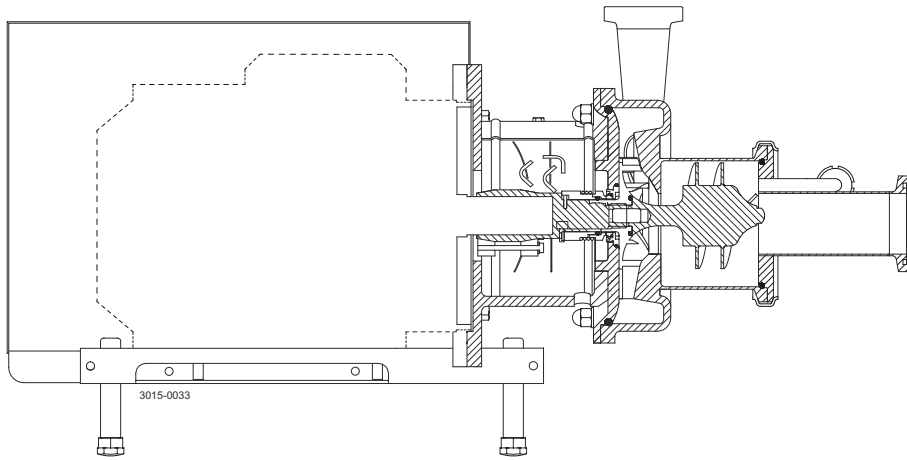

LKHex Prime

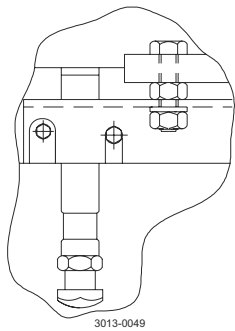

Only used for 3 kW
Fitting of legs

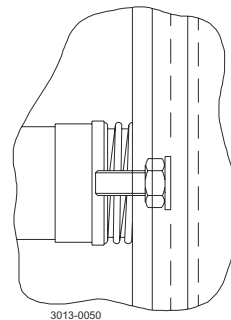

Fitting of back plate

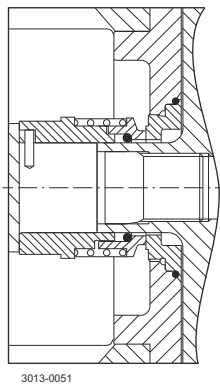

Single shaft seal

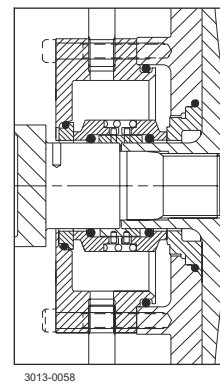

Double mechanical shaft seal

9.2 Parts list

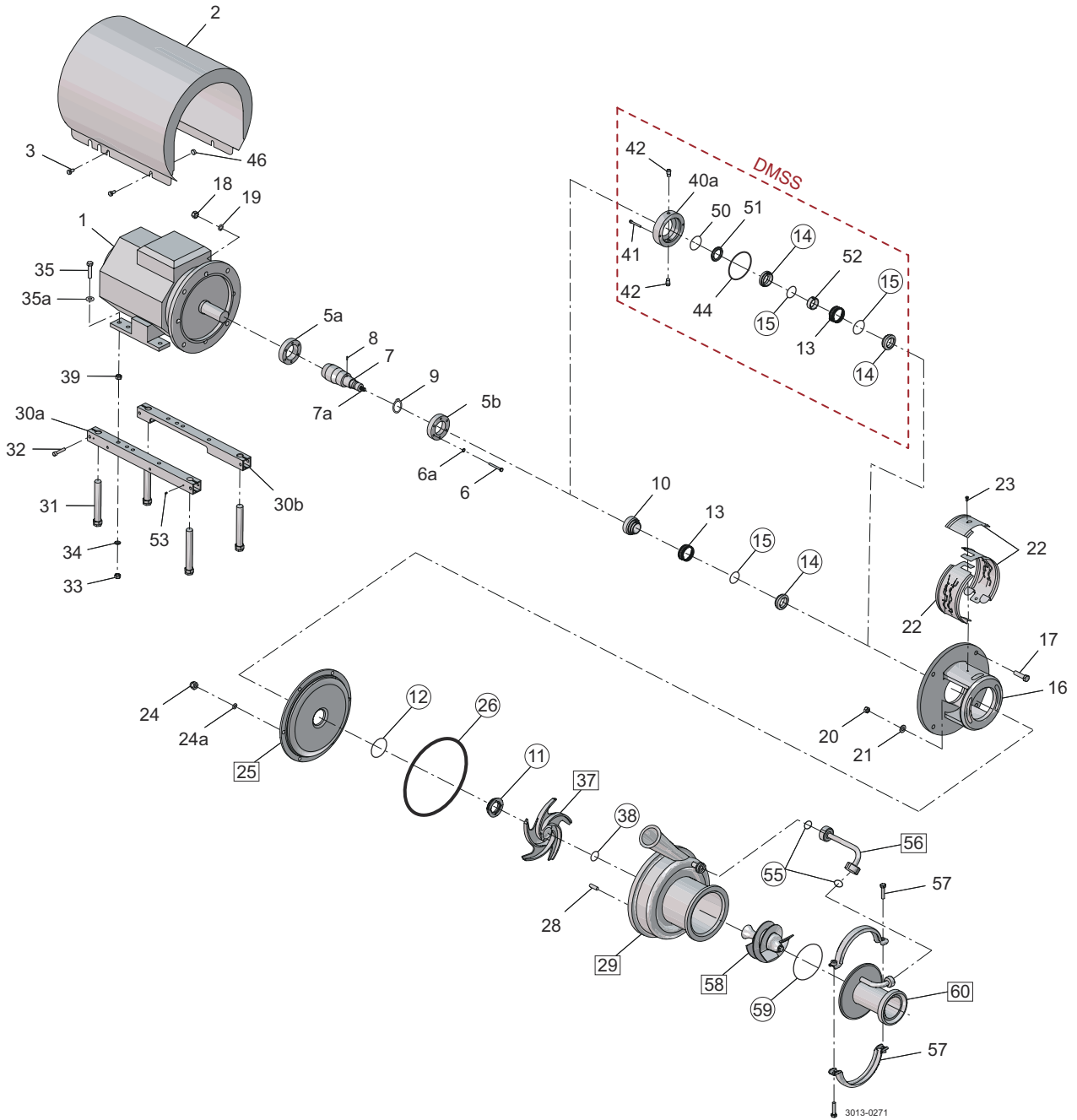

- Product wetted non-metallic parts
- Product wetted metallic parts

Pos.	Qty.	Denomination
1	1	Motor
2	1	Shroud
3	4	Screw
5	1	Compression ring
6	6	Screw
7	1	Shaft
8	8	Connex pin
9	1	Retaining ring
10	1	Drive ring
11	1	Stationary seal ring
12	1	O-ring
13	1	Spring
14	1	Rotating seal ring
15	1	O-ring
16	1	Adaptor
17	4	Screw
18	4	Nut
19	4	Washer
20	2	Nut
21	2	Washer
22	1	Safety guard set
23	1	Screw
24	6	Cap nut
25	1	Back plate
26	1	O-ring
28	6	Bolt

Pos.	Qty.	Denomination
29	-	Pump Casing
30	1	Support bar
31	4	Leg
32	4	Screw
33	4	Nut
34	4	Spring washer
35	4	Screw
37	1	Impeller
38	1	O-ring
39	4	Spacer for Leg
40	1	Seal housing
41	2	Screw for seal housing
42	2	Tube/fitting
44	1	O-ring for seal housing
46	4	Distance sleeve
50	1	O-ring
51	1	Sec. stationary seal ring
52	1	Drive ring
53	4	Pivot screw
55	2	O-ring
56	1	Recirculation pipe
57	1	Clamp set
58	4	Air screw
59	1	O-ring
60	1	Front cover