

# HEATING INSULATION INCLUDED

Thickness: 45 mm

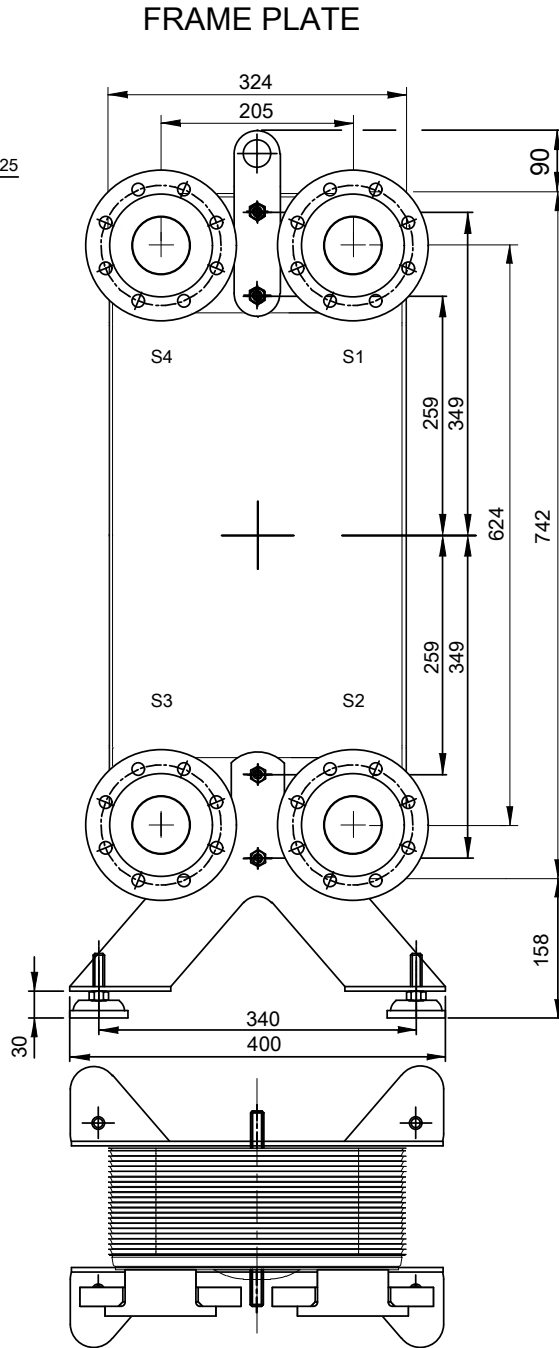

LFS DN80  
Alloy 304  
S1,S2,S3,S4

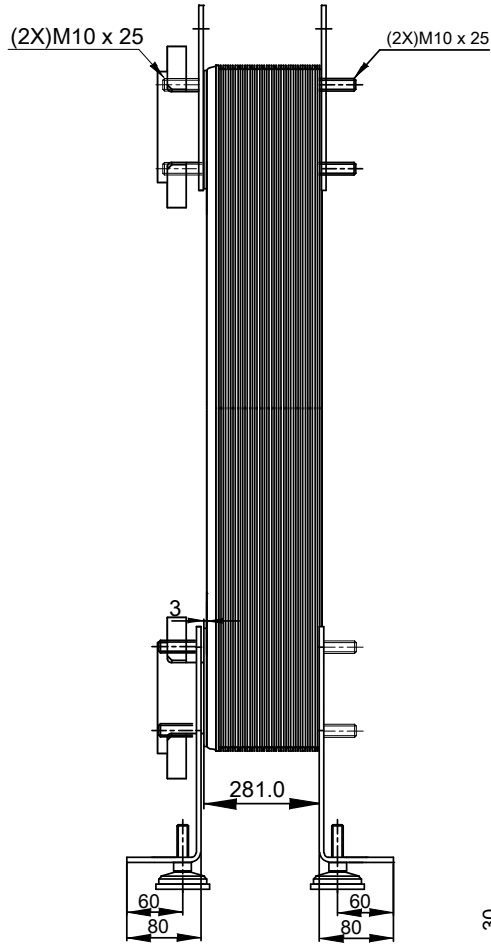
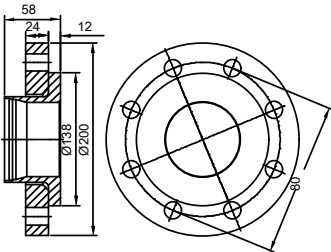

HEATING SURFACE  
NETWEIGHT 96.6 kg  
OPERATING WEIGHT kg  
PLATE MATERIAL ALLOY 316  
PLATE GROUPING 1\*49ML/1\*50MH

T1 T2 T3 T4 locations on back side  
correspond to S1 S2 S3 S4 on front side

ALL DIMENSIONS IN MILLIMETERS

SIDE	MEDIA	INLET	TEMP.	OUTLET	TEMP.	FLOW RATE	PRESSURE DROP	LIQUID VOL.
1		S1		S2				25.5 dm <sup>3</sup>
2		S3		S4				25.0 dm <sup>3</sup>

Note that all unique customer requirements (i.e tolerance) need to be verified thru Alfa Laval.

PRESSURE VESSEL APPROVAL

PED/UK

CB200-100M+Mounted insulation (3287000764)

www.alfalaval.com

CUSTOMER NAME / REF. NO.

COMPANY / REF.

TOTAL LENGTH 441.0 mm  
TOTAL WIDTH 324.0 mm  
TOTAL HEIGHT 990.0 mm



1/15/2024  
REV 0