

Alfa Laval in-line sight glasses

Tank Accessories

Content

- [LKFL in-line sight glass](#)
- [LKGG-1 and LKGL-1 in-line sight glass](#)

LKFL in-line sight glass

Introduction

The Alfa Laval LKFL In-line Sight Glass is an accurate, tight-fitting gauge glass that permits direct distortion-free visual inspection of process conditions, products, liquid levels and cleaning in a pipeline.

Application

The LKFL In-line Sight Glass is a rigid, hygienic sight glass housed in acid-resistant steel. It is designed for visual inspection of a product in a hygienic pipeline across the food, beverage, pharmaceutical and many other industries.

Benefits

- Reliably clear viewing quality
- Provide clear, continuous and unobstructed visibility of processes
- Sight glass construction and range

Standard design

The Alfa Laval LKFL In-line Sight Glass consists of a stainless steel semi-bright tube with two screw connections for the borosilicate glass discs. The connections are placed



opposite each other to enable positioning of the glass very close to the internal wall of the tube to facilitate cleaning.

The glass discs are internally sealed with EPDM rubber seals and, from the outside, pressed against the seal by a nut via a spacer.

An optional halogen light source, which is fitted onto one of the sockets, is available. The halogen light source consists of two stainless steel tubes assembled with a clamp.

The standard LKFL connections are welding ends. Upon request, the LKFL In-Line Sight Glass is also available with male part connections.

Technical data

Pressure	
Max. product pressure:	290 PSI (20 bar)
Min. product pressure:	Full vacuum
Max. pressure shock:	435 PSI (30 bar)

Temperature	
Temperature range:	14 °F to +284 °F. (EPDM)

Max. thermal shock:	D t 248 °F (284 °F P 68 °F)
Bulb, halogen:	24 V DC, 24 Watt, G4
Bulb socket standard:	G4, max. 35 V DC
Cable:	Max. OD 0.41 in
Reflector:	OD 1.97 in

Physical data

Materials	
Product wetted parts:	Acid-resistant steel AISI 316L
Other steel parts:	Stainless steel AISI 304
Glass:	Borosilicate glass
Seals:	EPDM rubber
Finish:	Semi bright

Sizes	
38 mm (1 1/2"), 51 mm (2"), 63.5 mm (2 1/2"), 76.1 mm (3") and 101.6 mm (4")	

Connections	
Type LKFL sight glass is available with welding ends or with male parts according to optional standards, e.g. ISO, DS, SMS, DIN, BS, or with clamp liners	

Dimensions (inch)

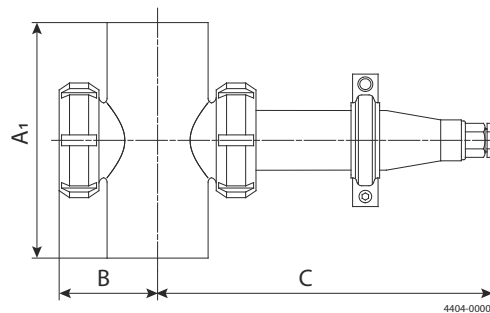

Size (in)	1½"	2"	2½"	3"	4"
A1	4.06	5.98	5.98	8.07	8.07
B	1.97	2.60	2.52	2.87	3.58
C	7.05	7.64	7.52	7.83	9.61
ID	0.79	1.34	1.34	1.73	2.36

Size (in)	1½"	2"	2½"	3"	4"
Weight (lb)					
Without light	1.76	4.19	2.65	3.75	7.28
With light	2.87	5.51	3.97	5.07	8.60

Overall length

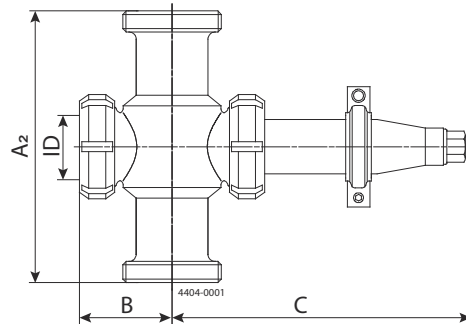

Size (in)	1½"	2"	2½"	3"	4"
SMS	5.59	7.56	7.87	9.92	10.78
DS	5.59	7.56	7.87	9.92	9.92
ISO clamp	5.04	6.97	6.97	9.02	9.29
IDF for ISO tube	5.71	7.68	7.68	9.72	9.72
IDF for SWG tube	5.71	7.68	7.68	9.72	10.39
BS	5.71	7.68	7.72	9.76	10.16
DIN	5.71	7.68	7.95	10.39	10.39

Options

Material grades

- Seals of Nitril (NBR) or flourinated rubber (FPM)

Ordering

Please state the following when ordering:

- Size
- Connections. If male parts, please state standard

LKGG-1 and LKGL-1 in-line sight glass

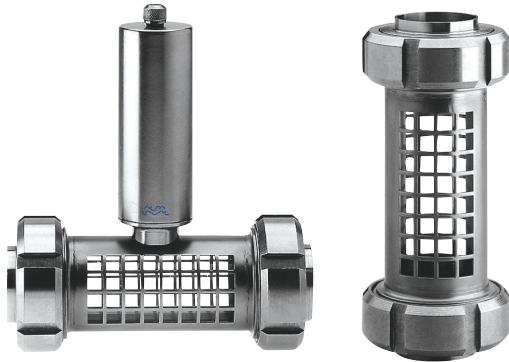

Introduction

The Alfa Laval LKGG-1 and LKGL-1 In-Line Sight Glass permits direct, distortion-free visual inspection of process conditions, product flow, liquid levels and cleaning status inside pipelines.

Affordable and easy-to-operate, the leakproof in-line sight glass makes it possible for operators to view the color, clarity, turbidity, or other critical characteristics of the product or cleaning status of the pipelines.

Technical data

Temperature

Recommended max. working temperature:	230 °F
Max. thermal shock:	212 °F
Bulb:	24 V / 24 W
Bulb socket:	B 15

Pressure

Max. working pressure (68 °F)	72.5 PSI (5 bar)
-------------------------------	------------------

Sizes

1", 1½", 2", 2½" and 3"

Physical data

Materials

Seals:	EPDM rubber
Steel grade:	Stainless steel AISI 304 or acidresistant steel AISI 316
Glass disc:	Borosilicate

Inspection enables early detection of potential issues and quick response. This helps prevent costly downtime, protect plant equipment and improve operational efficiency.

Application

The LKGG-1 and LKGL-1 In-Line Sight Glass is used in pipelines to facilitate clear, continuous and unobstructed inspection of various process conditions in hygienic applications across the dairy, food, beverage, personal care, biotechnology and pharmaceutical industries.

Benefits

- Improved operational efficiency
- Enables early detection and quick response to potential issues
- Reliable operation and more uptime
- Quick and easy to install
- Low maintenance requirements

Standard design

The Alfa Laval In-Line Sight Glass range is available in two types: Alfa Laval LKGG-1 and LKGL-1. The Alfa Laval LKGG-1 In-Line Sight Glass has a perforated stainless steel shield tube fitted with a welding union at each end. A special glass tube is fixed in the shield union to assure it is unaffected by potential stresses in the pipelines. The LKGL-1 is similar to LKGG-1 but has a stainless steel light fitting welded onto the shield tube to permit illumination of the product.

Dimensions (inch)

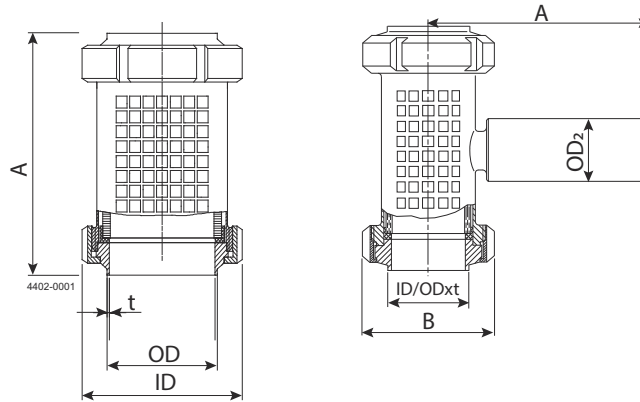

Size	1"	1.5"	2"	2.5"	3"	4"
A	6.89	7.13	7.4	7.64	7.87	-
B	2.52	3.03	3.58	4.17	4.8	5.83
OD	1.03	1.53	2.03	2.53	3.02	4.02
ID	0.89	1.4	1.91	2.38	2.83	3.84
t	0.07	0.07	0.06	0.07	0.09	0.09
Weight (lb)	2.20	3.31	4.41	5.51	7.94	-



Note!

- LKGL-1: + 1.10 lb
- Size 4" only for LKGG-1

Options

- Material grades
- Seals of Nitrile (NBR)

Ordering

Please state the following when ordering:

- Materials, AISI 304 or 316
- Type: LKGG-1 or LKGL-1
- Size

This document and its contents are subject to copyrights and other intellectual property rights owned by Alfa Laval AB (publ) or any of its affiliates (jointly "Alfa Laval"). No part of this document may be copied, re-produced or transmitted in any form or by any means, or for any purpose, without Alfa Laval's prior express written permission. Information and services provided in this document are made as a benefit and service to the user, and no representations or warranties are made about the accuracy or suitability of this information and these services for any purpose. All rights are reserved.

How to contact Alfa Laval

Up-to-date Alfa Laval contact details for all countries are always available on our website at www.alfalaval.com