

Alfa Laval M Gear

Gear Pump

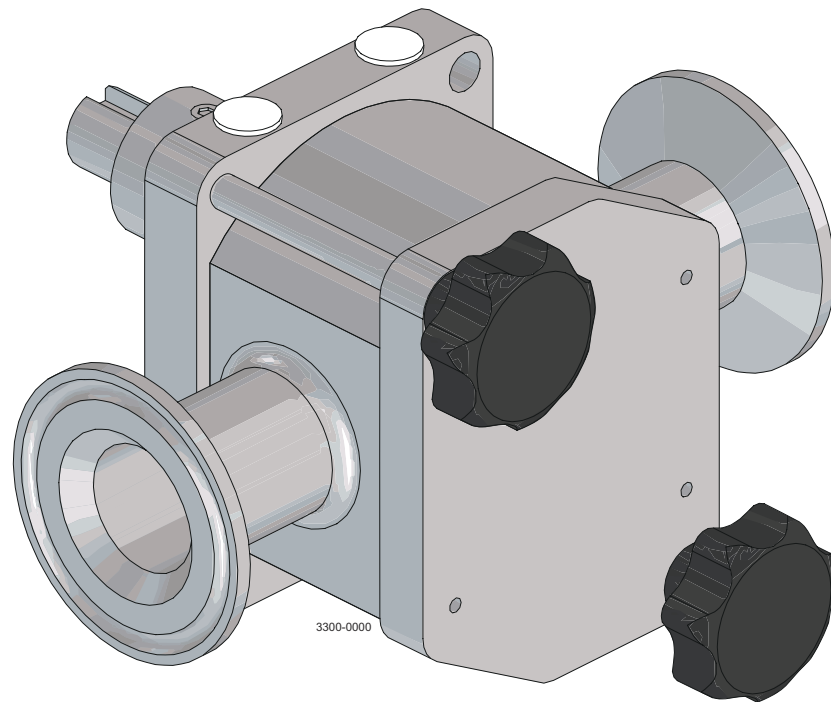

Lit. Code

200009584-3-EN-GB

Instruction Manual

Published by
Alfa Laval Kolding A/S
Albuen 31
DK-6000 Kolding, Denmark
+45 79 32 22 00

The original instructions are in English

© Alfa Laval AB 2024-01

This document and its contents are subject to copyrights and other intellectual property rights owned by Alfa Laval AB (publ) or any of its affiliates (jointly "Alfa Laval"). No part of this document may be copied, re-produced or transmitted in any form or by any means, or for any purpose, without Alfa Laval's prior express written permission. Information and services provided in this document are made as a benefit and service to the user, and no representations or warranties are made about the accuracy or suitability of this information and these services for any purpose. All rights are reserved.

Contents

1	Declarations of Conformity	5
1.1	EU Declaration of Conformity.....	5
1.2	UK Declaration of Conformity.....	6
2	Safety	7
2.1	Safety Instructions and Warnings.....	7
2.2	Warning Signs in Text.....	11
2.3	Requirements of Personnel.....	12
2.4	Recycling Information.....	13
3	Introduction	15
3.1	Principles.....	15
4	Installation	17
4.1	Unpacking and Handling.....	17
5	Operation	19
5.1	Commissioning and Start Up.....	19
5.2	Cleaning.....	19
6	Maintenance	21
6.1	Disassembly.....	22
6.2	Assembly.....	23
6.2.1	Assemble Drive Shaft Assembly.....	23
6.2.2	Assemble Pump.....	25
6.3	Troubleshooting.....	27
7	Technical Data	29
7.1	Weights.....	29
7.2	Dimensions.....	30
8	Spare Parts	31
8.1	Ordering Spare Parts.....	31
8.2	Alfa Laval Service.....	31
9	Parts List and Exploded View	33

This page is intentionally left blank.

1 Declarations of Conformity

1.1 EU Declaration of Conformity

The Designated Company

Alfa Laval Kolding A/S, Albuen 31, DK-6000 Kolding, Denmark, +45 79 32 22 00

Company name, address and phone number

Hereby declare that

Pump

Designation

M200; M210; M220

Type

Serial number from E10.000 to E1.000.000

Serial number from AAX000000001 to AAX999999999

is in conformity with the following directives with amendments:

- Machinery Directive 2006/42/EC
- RoHS Directive 2011/65/EU and amendments

The person authorised to compile the technical file is the signer of this document.

Global Product Quality Manager

Title

Lars Kruse Andersen

Name

Kolding, Denmark

Place

2023-06-19

Date (YYYY-MM-DD)

Signature

DoC Revison_01_062023



1.2 UK Declaration of Conformity

The Designated Company

Alfa Laval Kolding A/S, Albuen 31, DK-6000 Kolding, Denmark, +45 79 32 22 00

Company name, address and phone number

Hereby declare that

Pump

Designation

M200; M210; M220

Type

Serial number from E10.000 to E1.000.000

Serial number from AAX000000001 to AAX999999999

is in conformity with the following directives with amendments:

- The Supply of Machinery (Safety) Regulations 2008
- The Restriction of the Use of Certain Hazardous Substances in Electrical and Electronic Equipment Regulations 2012

Signed on behalf of: Alfa Laval Kolding A/S

Global Product Quality Manager

Title

Lars Kruse Andersen

Name

Kolding, Denmark

Place

2023-06-19

Date (YYYY-MM-DD)





Signature









DoC Revison_01_062023



2 Safety

 	<p>Read this first</p> <p>This manual is designed for operators and service engineers working with the supplied Alfa Laval product.</p> <p>Operators must read and understand the “Safety, Installation and Operating Instructions” of the respective product before carrying out any work or before you put the supplied product into service!</p> <p>Not following the instructions can result in serious accidents.</p> <p>This documentation describes the authorized way to use the supplied product.</p> <p>Alfa Laval will take no responsibility for injury or damage if the equipment is used in any other way.</p> <p>This Instruction manual is designed to provide the user with the information to perform tasks safely for all phases in the lifetime of the supplied product.</p> <p>The user shall always read the safety section first. Hereafter the user can skip to the relevant section for the task to be carried out or for the information needed.</p> <p>Always read the technical data thoroughly (see Technical Data on page 29).</p> <p>This is the complete manual for the supplied product.</p>
--	--

2.1 Safety Instructions and Warnings

Safety Signs	
	Use eye protection - safety glasses.
	Use protective hand wear - safety gloves.
	Wear protective equipment - safety helmet.
	Use ear protection in noisy environments - noise protector.
	Wear protective equipment - safety shoes.
	Corrosive substance.
	Hot surface and burning danger.
	Cutting danger

Safety Signs



Dangerous electrical voltage



Transportation with forklift truck or other industrial vehicles if heavy.

General Safety Precautions



Installation

If the local safety regulations prescribe that the installation has to be inspected and approved by responsible authorities before the pump is put into service, consult with such authorities before installing the equipment and have the projected installation approved by them.



Never start in the wrong direction of rotation with liquid in the pump.

Never put your hands or fingers inside the port connections or anywhere close to rotating shafts.



Always have the pump electrically connected by authorized personnel. (See the motor instruction supplied with the drive unit)

Alfa Laval recommends the supply disconnecting device shall be in accordance with EN 60204-1.



Operation

Never stand on the pump or pipelines.

Never run the pump with either the suction side or the pressure side blocked.



Never put your hands or fingers inside the port connections or anywhere close to rotating parts.

Never run the pump unless fully assembled and all guards are securely fitted, i.e. pump head must not be removed from gearcase. !



Always ensure any guards are securely fitting and in good condition.

Never touch the pump or the pipelines when pumping hot liquids or when sterilising.

In certain operating conditions external surfaces of the pump and/or ancillary equipment may exceed 80° C. As such users should avoid touching the pump and/or ancillary equipment during operation taking precautions if it is unavoidable to do so.



Only handle toxic and acidic liquids in accordance with the manufacturers instructions and recommendations.

	<p>Maintenance</p> <p>Always ensure adequate Personal Protective Equipment (PPE) is worn during any maintenance activities.</p> <p>Never service the pump when it is hot.</p> <p>Never service the pump when the pump and pipelines are pressurised.</p> <p>Never put your hands or fingers inside the port connections or anywhere close to rotating parts.</p> <p>Always comply with any local health and safety regulations when installing and operating the pump.</p> <p>Any hazardous and/or hot, drained or leaked, liquid shall be disposed in compliance with any local health and safety regulations. If requested at the time of quotation, the equipment can be supplied with a means of safe containment of any hazardous and/or hot, drained or leaked liquid (Drip Pan).</p> <p>Always ensure the power supply is disconnected (in an off position) and is locked out to prevent accidental operation. Please refer to any motor/geared motor and coupling operating manuals supplied with the unit for maintenance instructions.</p> <p>Always ensure pump and ancillary equipment has been allowed to cool before touching.</p>
---	--

	<p>Transportation and Lifting</p> <p>Never lift or elevate in any way other than described in this manual</p> <p>Always drain the pump head and accessories of any liquid</p> <p>Always ensure that no leakage of lubricants can occur</p> <p>Always transport the pump in it's upright position</p> <p>Always ensure that the unit is securely fixed during transportation</p> <p>Always use original packaging or similar during transportation</p> <p>Always use a suitable transport device i.e. forklift truck or pallet lifter</p>
--	--

	<p>Storage</p> <p>Ideally, as a guide Alfa Laval recommend:</p> <ul style="list-style-type: none"> • Store supplied product as supplied in original packaging • Port opening should be protected against any ingress • Bare steel (not stainless) should be lightly oiled/greased • Store in a clean, dry place without direct sunlight or UV light • Temperature range -5 to 40° C • Relative humidity less than 60% • No exposure to corrosive substances (also air contained)
---	--

	<p>Noise</p> <p>Under certain operating conditions pumps and/or drives and/or the systems within which they are installed can produce sound pressure levels in excess of 80 dB[A].</p> <p>When necessary, protection against noise should be taken.</p>
---	--

Safety check



A visual inspection of any protective device (shield, guard, cover or other) on the supplied product shall be carried out at least every 12 months. If the protective device is lost or damaged, especially when this leads to deterioration of safety performance, it shall be replaced. The fixing of the protective device should only be replaced with fixings of the same or an equivalent type.

Inspection acceptance criteria:

- It should not be possible to reach moving parts originally protected by a protective device
- The protective device must be securely mounted
- Ensure that screws for the protective device are securely tightened

Procedure in case of non-acceptance:

- Fix and/or replace the protective device

How to contact Alfa Laval

Contact details for all countries are continually updated on our website.

Please visit www.alfalaval.com to access the information directly.

2.2 Warning Signs in Text

Pay attention to the safety instructions in this manual.

Below are definitions of the four grades of warning signs used in the text where there is a risk for injury to personnel or product damage.



Indicates an imminently hazardous situation which, if not avoided, will result in death or serious injury.



Indicates a potentially hazardous situation which, if not avoided, could result in death or serious injury.



Indicates a potentially hazardous situation which, if not avoided, may result in minor or moderate damage on the product.



Indicates important information to simplify or clarify procedures.

2.3 Requirements of Personnel

Operators

The operators shall read and understand the instruction manual for the supplied product.

Maintenance personnel

The maintenance personnel shall read and understand the instruction manual. The maintenance personnel or technicians shall be skilled within the field required to carry out the maintenance work safely.

Trainees

Trainees can perform tasks under the supervision of an experienced employee.

People in general

The public shall not have access to the supplied product.

In some cases special skilled personnel may need to be hired, like electricians and others. In some of these cases the personnel has to be certified according to local regulations with experience of similar types of work.

How to contact Alfa Laval

Contact details for all countries are continually updated on our website.

Please visit www.alfalaval.com to access the information directly.

2.4 Recycling Information

Unpacking

Packing material consists of wood, plastics, cardboard boxes and in some cases metal straps.



- Wood and cardboard boxes can be reused, recycled or used for energy recovery
- Plastics should be recycled or burnt at a licensed waste incineration plant
- Metal straps should be sent for material recycling

Maintenance

During maintenance oil and wear parts in the machine are replaced.

- Oil and all non-metal wearing parts must be disposed of in accordance with local regulations
- Rubber and plastics should be burnt at a licensed waste incineration plant. If not available they should be disposed in accordance with local regulations
- Bearings and other metal parts should be sent to a licensed handler for material recycling
- Seal rings and friction linings should be disposed to a licensed land fill site. Check your local regulations
- All metal parts should be sent for material recycling
- Worn out or defected electronic parts should be sent to a licensed handler for material recycling

Scrapping

- At end of use, the equipment must be recycled in accordance with the relevant local regulations. Besides the equipment itself, any hazardous residues from the process liquid must be considered and dealt with in a proper manner. When in doubt, or in the absence of local regulations, please contact your local Alfa Laval sales company.

This page is intentionally left blank.

3 Introduction

The Alfa Laval M Gear is an external gear pump that efficiently transfers low-volume fluids for filling applications. Precision alignment, easy cleaning and simple maintenance make the stainless-steel M Gear pump a solid choice for dosing, sampling and filling machines. This proven rotary positive displacement pump easily adapts to OEM filling machines.

3.1 Principles

The M Gear pump supplied is a positive displacement gear pump which may be supplied with or without a drive unit. The drawing below indicates the main components of the pump.

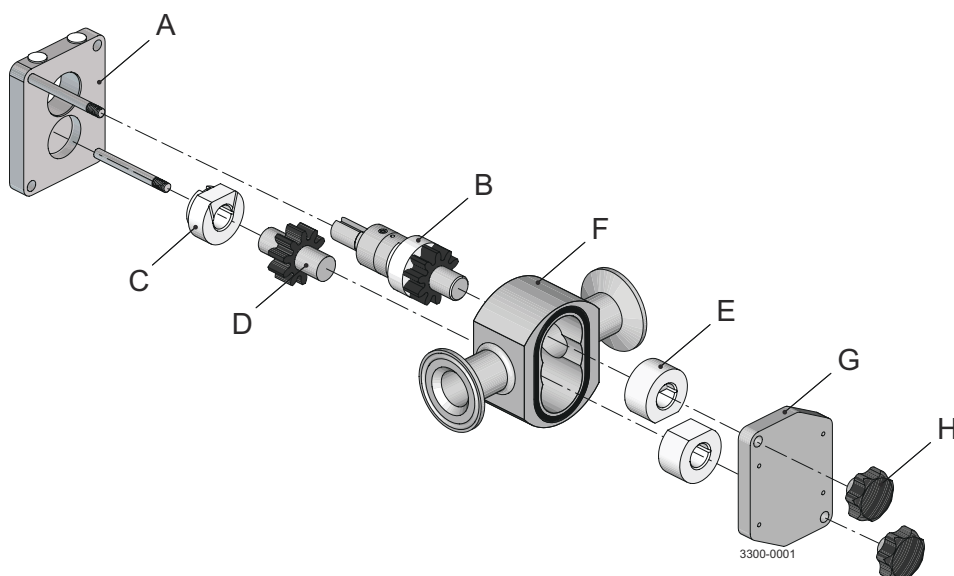

Item	Description	Item	Description
A	Back Plate	E	Front Bushing
B	Drive Shaft Assembly	F	Body
C	Rear Bush (Aux. shaft)	G	Front Cover
D	Auxiliary shaft	H	Hand Nut

Principle of Operation

The M Gear pump has two counter gears and can operate in both flow directions by reversing the drive rotation.

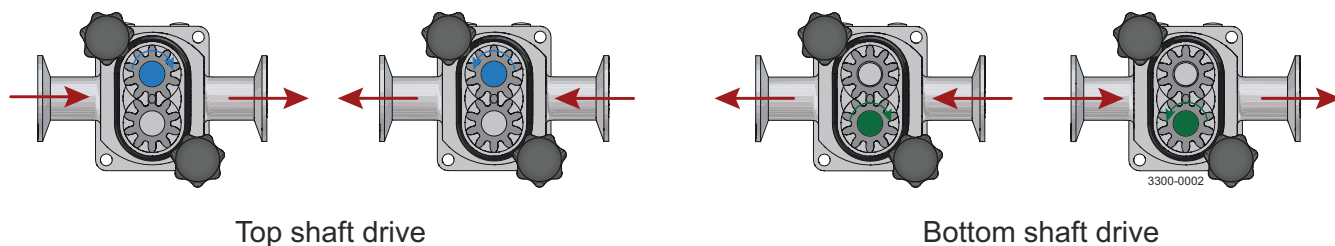

As the gear rotate within the body the volume at the inlet increases and the product is drawn in to the pump. It is then transported within the space between the gears and the periphery of the body to the discharge side where the volume between the gears is reduced and the product is discharged.

Pump Limits of Application and Use

This pump has been designed for pumping a range of clean, semi-solid viscous products for transfer, dosing and sampling in the food, chemical and associates industries.

Pressures up to 7 bar, speeds up to 1360 rpm and temperatures up to 60°C can be obtained on this pump range depending on model. These conditions cannot always be accommodated simultaneously. The model type/size will be shown on the nameplate positioned on the pump.

If the user has not specified the pumping application or needs to change it, it is important to confirm that the materials of construction and product seals are compatible with the pumped liquid.

For specific guidelines contact your supplier quoting pump serial number, system and duty details. (e.g. media, pressures, flowrate, pumping temperatures etc).

Duty conditions

The pump should only be used for the duty for which it has been specified. The operating pressure, speed and temperature limits have been selected at the time of order and **MUST NOT** be exceeded. These details are stated on the original documentation and if not available may be obtained from your supplier quoting pump serial number

Utility requirements

Electrical supply: This pump may be supplied bareshaft or coupled to an electric motor. See motor nameplate for electrical supply requirements.

4 Installation

4.1 Unpacking and Handling

Receipt and unpacking

On receipt always:

- Check the delivery note against good received
- If motorised check that the drive instructions are available
- Inspect packing for signs of damage in transit
- Carefully remove packing away from the pump
- Clean away packing form the pump port connections
- Ensure any manuals are taken out of the packing before discarding
- Inspect the pump unit for any signs of damage
- Report any damage immediately to the carrier

Handling

WARNING

Always ensure any personnel undertaking lifting operations have the suitable experience and training to do so safely.

Ensure any lifting equipment used is in good condition and has been suitably tested, using lifting lugs when applied.

Ensure any lifting equipment used is rated for and used within the load limits. Refer to the pump weights guide.

Always ensure that the lifting points are in line with the centre of gravity and adjust lifting point if necessary.

Always keep an eye on the load and stay clear during the lifting operation.

The diagrams below show examples of how the equipment should be lifted, however the user is to ensure this can be done safely with the equipment at hand:

Motorised

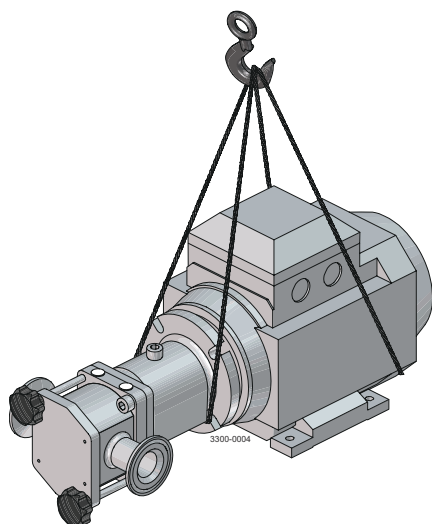

This page is intentionally left blank.

5 Operation

5.1 Commissioning and Start Up

Pump Lubrication

The M Gear pump range does not require any external lubrication.

Pre-Start Up Checks

- Check the pipework systems has been flushed to remove debris such as welding slag or other hard solids
- Check all obstructions have been removed from the pipework and pump
- Check pump connections and pipework are tight and leak-free
- Check pump lubrication levels in both pump and drive unit (if applicable)
- Check that any safety guards or devices are in place and in good condition
- Check that the inlet and outlet valves are open
- Start the pump briefly to ensure correct direction of rotation and presence of fluid.
- Start pump and check the operating conditions are within the operating limits of the pump.

In the event of any unusual noise, vibration or leakage the unit should be shut down immediately and the problem investigate and rectified before restarting.

5.2 Cleaning

The M Gear pump has been designed for Clean Out of Place (COP) manual cleaning only.

This page is intentionally left blank.

6 Maintenance

Maintenance Schedule

The below checks are to be carried out when the pump is not operational and any electrical supply has been safely disconnected and isolated so accidental operation cannot occur. In certain circumstances the pump will pose a thermal hazard and as such should not be touched until allowed to reach a safe temperature before undertaking checks.

Weekly Checks

- Check product seal for leakage and replace if necessary
- Check pumping pressures
- Check rubber joints for condition and incompatibility

Yearly Checks (in addition to the above)

- Remove front cover, bushes and check wet end components for wear and damage

Recommended Spare Parts

The table details recommended spares parts that should be retained within your maintenance schedule.

Pos.	Description	Qty.
19, 20, 21, 22	Gear/Shaft Assembly	2
4, 9	Bush	4
5	Joint ring	2
14, 15, 16, 17, 18	Seal Assembly	1

6.1 Disassembly

Before dismantling the pump refer to safety precautions in Section [Safety](#) on page 7.

Refer to exploded diagram and parts list in Section [Parts List and Exploded View](#) on page 33.

! NOTE

It is recommended to mark positions of the gears, body and cover (e.g. Top/Bottom or Left/Right) prior to removal to ensure parts are refitted in the same position.

- 1 Disconnect the pipe connections from the body (1).
- 2 Release coupling on drive shaft (19).
- 3 Unscrew hand nuts (7) and remove front cover (3). **DO NOT LEVER OFF.**

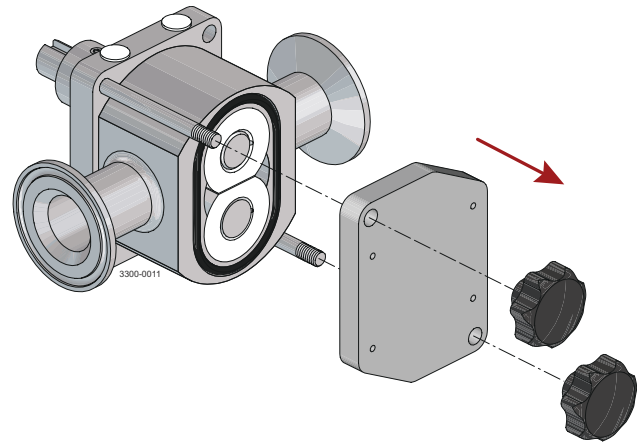

- 4 Remove body (1) together with the Front and Rear body O-rings (5). **NOTE:** Front bushes (4) may stay in the body but can be removed by pushing out.

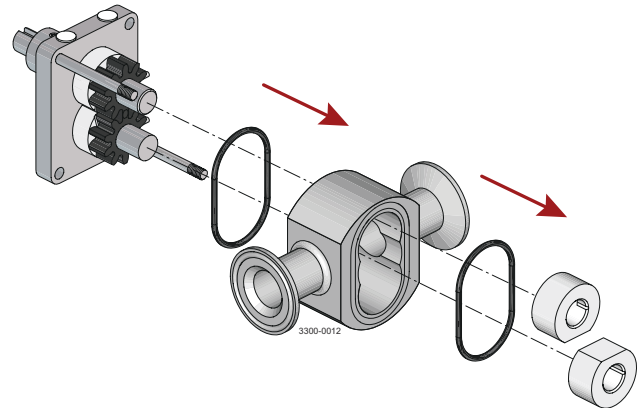

- 5 Remove the auxiliary shaft (22) with gear (20) and the rear bush (9) from the back plate (2).

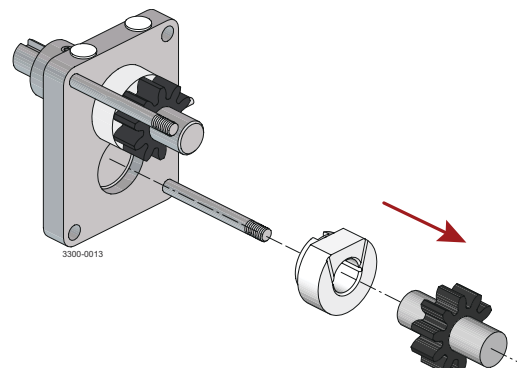

- 6 Remove the drive shaft assembly (19) complete with the rear bush (9), gear (20) and seal assembly. **NOTE:** The back plate (2) can remain fixed to the motor (or other mounting as applicable) whilst dismantling is carried out.

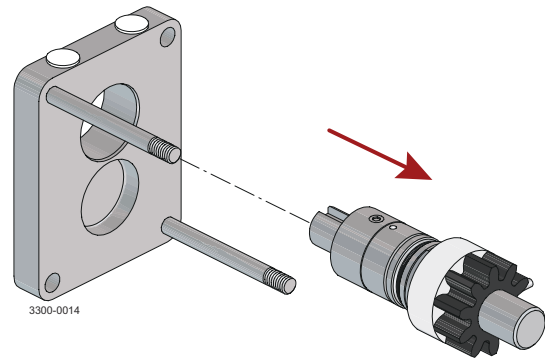

- 7 Loosen the seal retaining screws (13) and remove the seal assembly and rear bush (9) from the drive shaft.

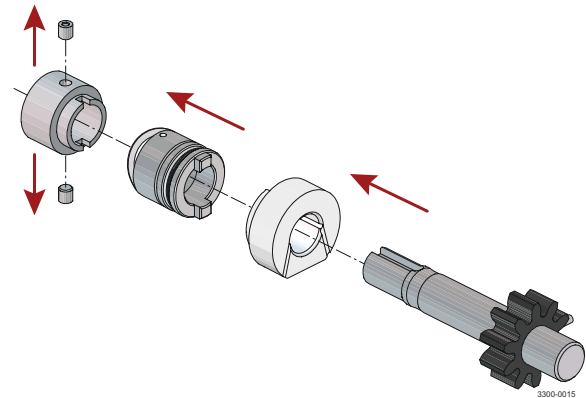

6.2 Assembly

6.2.1 Assemble Drive Shaft Assembly

- 1 Slide rear bush (9) on to the drive shaft with the smaller diameter away from the gear face.

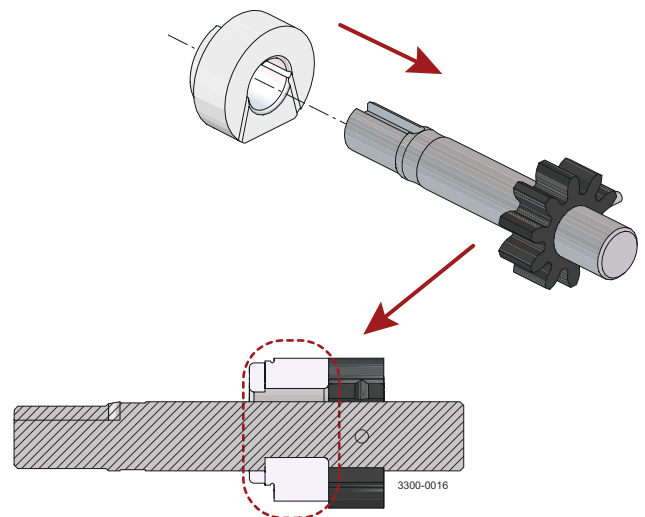

- 2 Fit O-ring (18) on to stationary seal ring (17) over the seal face end then fit stationary seal ring to the shaft, aligning the tabs on the seal ring with the slots in the rear bush. Clean seal face with a suitable solvent.

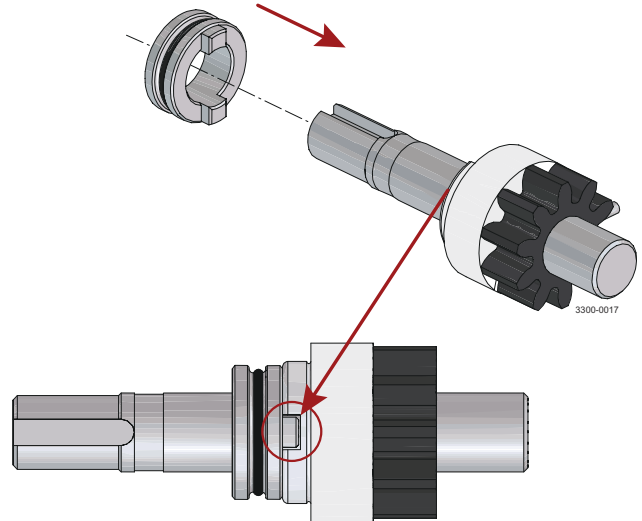

- 3 Fit O-ring (15) in the rotary seal ring (16) from the rear. Clean the rotary seal face with a suitable solvent and slide onto the shaft.

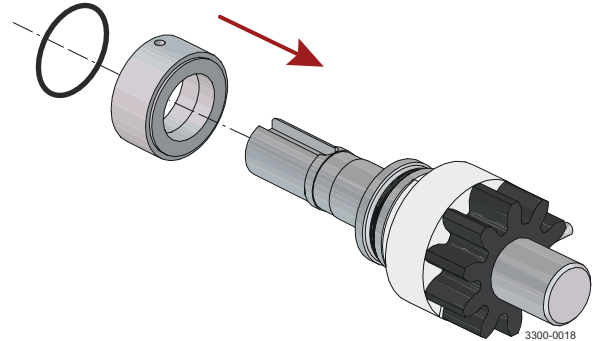

- 4 Fit wave spring (14) on to spring retainer (12), then slide the spring retainer on to the shaft ensuring to align the pins in the rotary seal with the slots in the spring retainer fully until the seal faces meet and the spring is fully compressed.

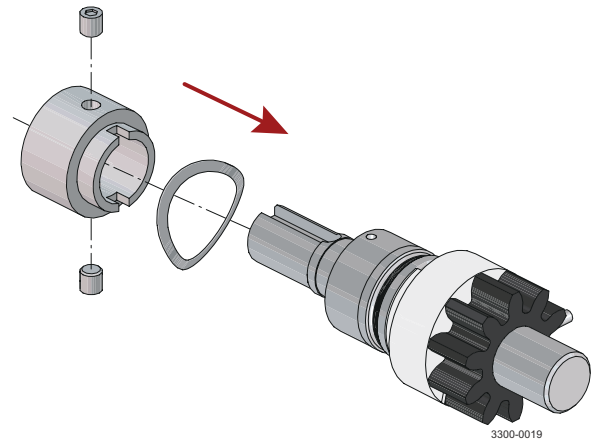

- 5 Gently move the spring retainer back, releasing the spring pressure until the gap between the spring retainer and rotary seal ring is 1.5mm (0,059").

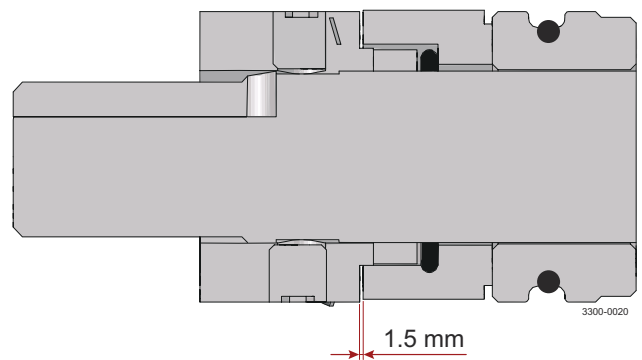

- 6 Tighten retaining screws (13) equally and gradually until hand tight.

6.2.2 Assemble Pump

- 1 Fit one rear bush (9) in to the bore in the back plate (2) with the flat side towards the middle of the pump.

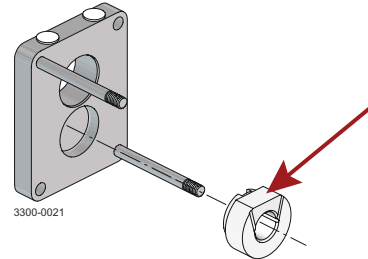

- 2 Press, by hand, the drive shaft assembly into (through) the bore in the back plate (2) until fully seated, making sure the flat sides of the bushes are aligned.

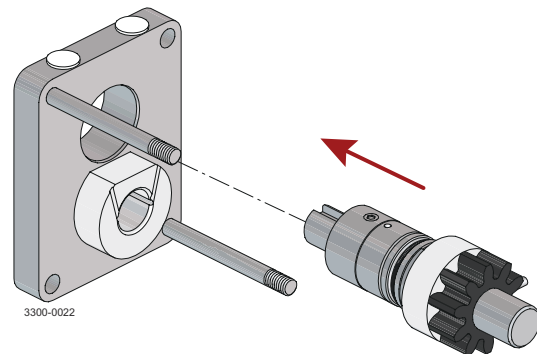

- 3 Slide auxiliary shaft (22), with gear, in to position in the back plate (2). Both ends of the shaft are identical.

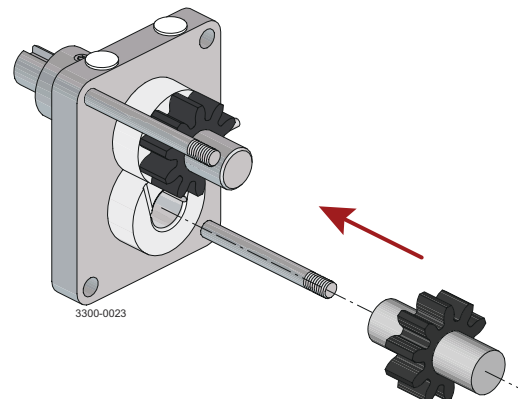

- 4 Fit 1 of the O-rings (5) to the back of the body (1). The ports are offset from the centerline of the body, with the narrowest width towards the back (as shown).

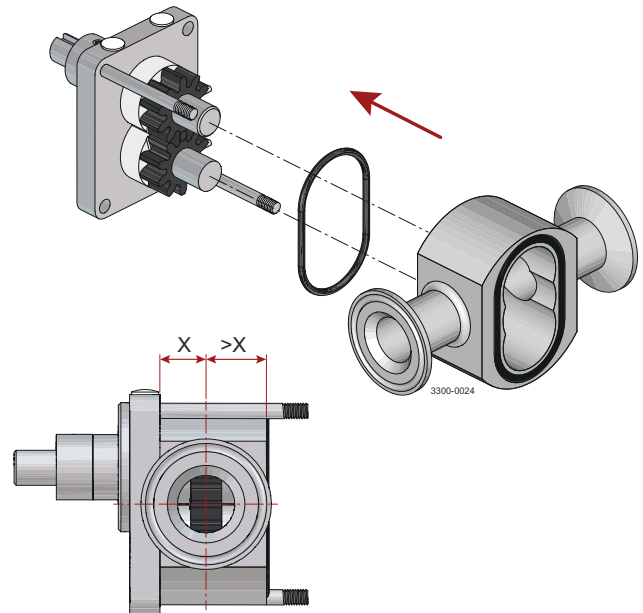

- 5 Slide body (1) over the gears and locate it on the rear bushes.

- 6 Fit the front bushes (4) on to the shafts, ensuring the flat sides of the bushes are aligned. Fit second O-ring (5) to body, then fit front cover (3) over the studs. Tighten the hand nuts (7) evenly. - **DO NOT OVER TIGHTEN.**

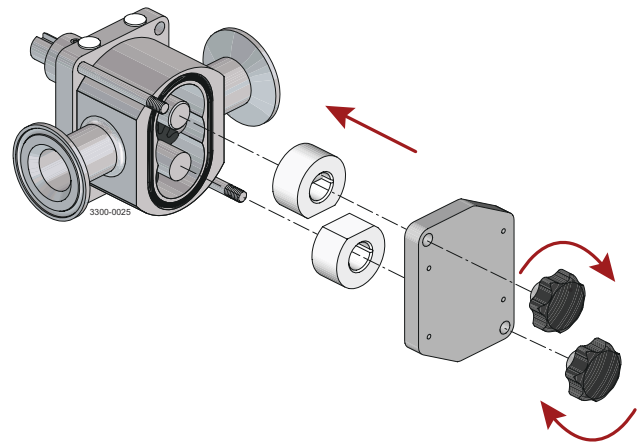

- 7 Refit coupling half (30) to the drive shaft (if applicable).

- 8 Rotate the drive shaft to check for free rotation (using the coupling 30) if fitted.

- 9 Reinstall the pump and reconnect any pipework ensuring all connections are tight. Ensure any guards removed are refitted and in good condition before restarting equipment.

6.3 Troubleshooting

Problem

- | | | |
|-------------------------------|-----------------------------|---------------------------------------|
| 1. No discharge | 6. Pump overheats | 11. Excessive primary seal wear |
| 2. Under capacity | 7. Motor overheats | 12. Product loss through primary seal |
| 3. Irregular discharge | 8. Excessive power absorbed | 13. Seizure |
| 4. Prime lost after starting | 9. Noise & vibration | |
| 5. Pump stalls after starting | 10. Pumping element wear | |

Problem													Causes	Remedies	
1	2	3	4	5	6	7	8	9	10	11	12	13			
•														Incorrect direction of rotation	Reverse drive
•														Pump Un-primed	Expel gas from supply line and pumping chamber, introduce liquid
•	•	•	•					•						Insufficient NPSH available	Increase supply line diameter, increase suction head. Simplify supply line configuration & reduce length. Reduce speed. Decrease product temp., check effect of increased viscosity on available & permitted power inputs
•	•	•	•					•						Air entering supply line	Remake pipework joints, check primary seal
	•	•	•					•						Gas in supply line	Expel gas from supply line & pumping chamber, introduce liquid
•	•	•	•					•						Insufficient head above vessel outlet	Raise product level. Lower outlet position
	•	•						•						Inlet valve strainer blocked	Service fittings
	•		•	•	•	•	•	•						Product viscosity above rated capa?	Decrease pump speed. Increase product temperature
	•													Product viscosity below rated capa?	Increase pump speed. Increase product temperature
					•			•	•				•	Product temp. above rated temp.	Cool the pumping chamber
				•		•	•							Product temp. below rated temp.	Heat the pumping chamber
								•	•	•	•		•	Unexpected solids in product	Clean system. Fit strainer to inlet line.
	•	•	•	•	•	•	•	•	•				•	Delivery pressure above rated capa?	Check for obstruction. Service system to prevent problem recurring. simplify
						•	•	•						Pump speed above rated figure	Decrease pump speed
	•													Pump speed below rated figure	Increase pump speed
	•				•	•	•	•	•				•	Rotorcase strained by pipework	Check alignment of pipes. Fit flexible pipes or expansion fittings. check pipework support

Problem													Causes	Remedies	
1	2	3	4	5	6	7	8	9	10	11	12	13			
								.						Flexible coupling misaligned	Check alignment & adjust mounts accordingly
					Insecure pump drive mounts	Fit lock washers to loose fasteners & retighten
				Shaft bearing wear of failure	Refer to pump manual for replacement parts
					Worn or un-synchronized timing ge?	Refer to pump manual for replacement parts
				Gear case oil quantity incorrect	Refer to pump manual for instructions
.	.													Contact of pumping parts	Check rated & actual duty pressures
	.							.						Relief valve leakage	Check pressure setting & adjust if required. Examine & clean seating surfaces, replace worn parts.
	.							.						Relief valve chatter	Check for wear on sealing surfaces, replace f necessary

Problem

- | | | |
|-------------------------------|-----------------------------|---------------------------------------|
| 1. No discharge | 6. Pump overheats | 11. Excessive primary seal wear |
| 2. Under capacity | 7. Motor overheats | 12. Product loss through primary seal |
| 3. Irregular discharge | 8. Excessive power absorbed | 13. Seizure |
| 4. Prime lost after starting | 9. Noise & vibration | |
| 5. Pump stalls after starting | 10. Pumping element wear | |

7 Technical Data

Pump Data Table

Pump Model	Speed	Flow Rate (65 cp Product)		Port Size	Max. Working Pressure		Max. Speed
	(rpm)	(l/hr)	usgpm		bar	psi	
M200	690	250	1.10	1/2"*/ 1"	7	101	1360
	900	325	1.43				
	1360	485	2.13				
M210	690	400	1.76	1/2"*/ 1"	7	101	1360
	900	525	2.31				
	1360	780	3.43				
M220	690	770	3.39	4	101	1360	
	900	1000	4.40				
	1360	1500	6.60				

* BSP Female Only

7.1 Weights

Pump Model	Typical Bareshaft Pump		Typical Pump with Drive	
	kg	lbs	kg	lbs
M200	2.0	4.4	9.7 – 13.6	21.4 – 30.0
M210	2.2	4.9	9.9 – 13.8	21.9 – 30.4
M220	2.8	6.2	10.5 – 14.4	23.2 – 31.8

The above weights are for guidance only.

7.2 Dimensions

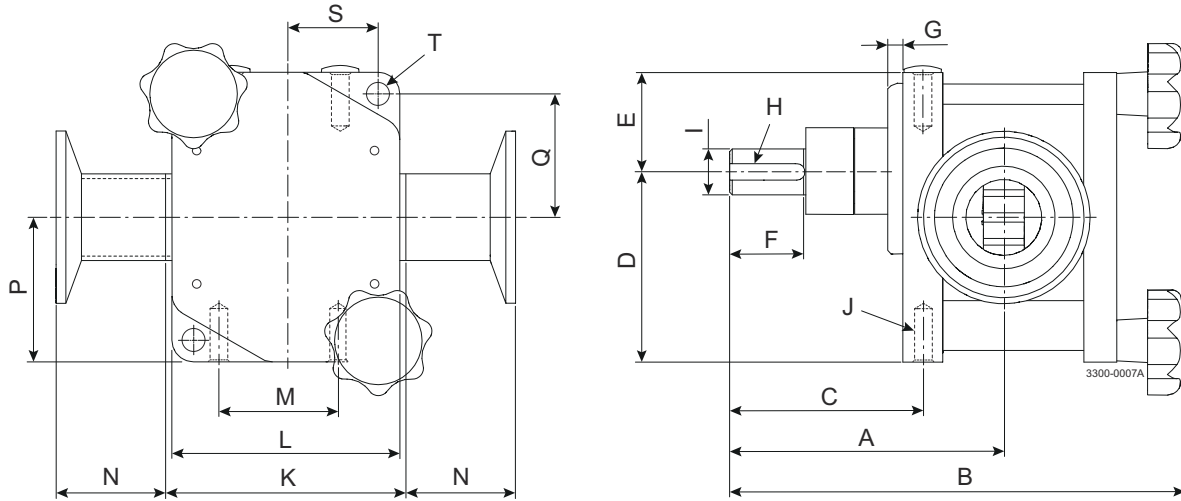

Dimensions (mm)

Models	A			B			C	D	E	F	G	H	I	J	K	L	M	N	P	Q	S	T
	1	2	3																			
M200	75.5	132	132	132	52	57	28	20	3	5*3	14	M6*12	70	67	32	52	42.5	36	27	ø6.5		
M210	75.5	132	132	132	52	57	28	20	3	5*3	14	M6*12	70	67	32	52	42.5	36	27	ø6.5		
M220	89	159	159	159	52	57	28	20	3	5*3	14	M6*12	70	67	32	52	42.5	36	27	ø6.5		

1 1/2" BSP
 2 1" Triclamp / SM
 3 1" DIN11851

Dimensions (inch)

Models	A			B			C	D	E	F	G	H	I	J	K	L	M	N	P	Q	S	T
	1	2	3																			
M200	2.97	5.19	5.19	5.19	2.05	2.24	1.1	0.79	0.12	0.2 ^{+0.1} ₁	0.55	7/32"	2.75	2.64	1.26	2.05	1.67	1.42	1.06	ø0.25		
M210	2.97	5.19	5.19	5.19	2.05	2.24	1.1	0.79	0.12	0.2 ^{+0.1} ₁	0.55	7/32"	2.75	2.64	1.26	2.05	1.67	1.42	1.06	ø0.25		
M220	3.5	6.25	6.25	6.25	2.05	2.24	1.1	0.79	0.12	0.2 ^{+0.1} ₁	0.55	7/32"	2.75	2.64	1.26	2.05	1.67	1.42	1.06	ø0.25		

1 1/2" BSP
 2 1" Triclamp / SM
 3 1" DIN11851

8 Spare Parts

For every delivered Alfa Laval Product, a spare part list is available.

This spare part list contains a range of the most common wear parts for the machinery. If any component not mentioned is required, please contact your local Alfa Laval representative for availability.

You can find our spare part catalogue at <https://hygienicfluidhandling-catalogue.alfalaval.com/>

Always use Alfa Laval genuine spare parts. The warranty of Alfa Laval products is dependent on use of Alfa Laval genuine spare parts.

8.1 Ordering Spare Parts

When ordering spare parts, please always state:

1. Serial number (if available)
2. Item number/spare part number (if available)
3. Capacity or other relevant identification

8.2 Alfa Laval Service

Alfa Laval is represented in all larger countries of the world.

Do not hesitate to contact your local Alfa Laval representative, with any questions or requirement of spare parts for Alfa Laval equipment.

This page is intentionally left blank.

9 Parts List and Exploded View

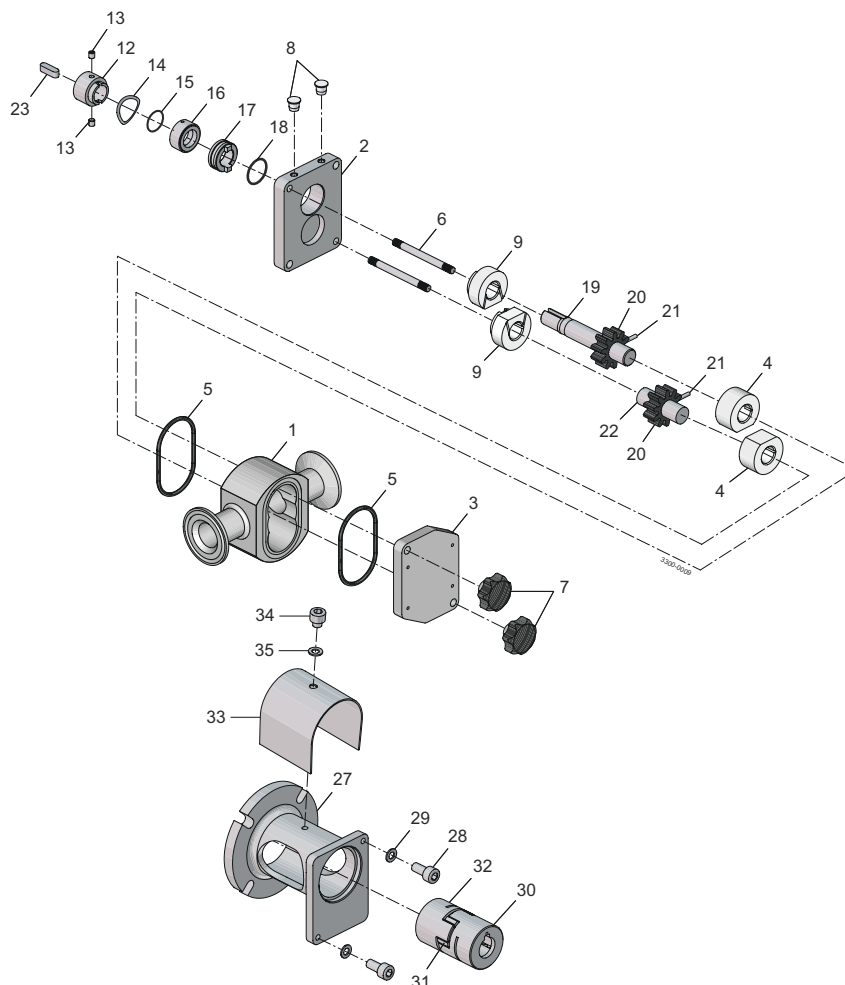

Item	Qty	Description	Item	Qty	Description
1	1	Body	17	1	Static Seat
2	1	Back Plate	18	1	O-ring
3	1	Cover	19, 20, 21	1	Drive Shaft Assembly
4	2	Bush, Front	20, 21, 22	1	Auxillary Shaft Assembly
5	2	Joint ring	23	1	Key
6	2	Stud	27	1	Motor Flange Bracket (if applicable)
7	2	Nut, Quick Release	28	2	Screw
8	2	Plug	29	2	Washer
9	2	Bush, Rear	30	1	Coupling Hub, Pump
12	1	Spring Retainer	31	1	Coupling Spider
13	2	Screw	32	1	Coupling Hub, Motor
14	1	Wave Spring	33	1	Coupling Guard
15	1	O-ring, EPDM	34	1	Screw, Coupling Guard
16	1	Rotary Seal Ring	35	1	Washer, Coupling Guard

Recommended spare parts: Shaft seal assy (pos 14 to 18) and pos 4, 5, 9 and 13

Parts depending on specification supplied, not all parts used on all specifications