



LYNX range

Decanter centrifuges for controlling drill solids

Applications

For drill solids control, high-speed separation, barite recovery, system de-weighting and ultrafines removal.

Optimizing drilling fluids

Alfa Laval decanter centrifuges are a key component in a top-quality solids control process. This technology efficiently removes most of the fine particles that traditional solids control equipment cannot deal with.

Specially designed and built for heavy-duty jobs in this field, the Alfa Laval LYNX range of decanter centrifuges is able to handle large amounts of feed solids, as well as coping well with abrasive and coarse particles.

LYNX decanter centrifuges are available with a range of modules ideally suited for every kind of solids separation job in conjunction with the drilling fluids used on drilling rigs and platforms. These modules range from fully automated operation to simple “hands-on” capabilities, providing effective solutions to all your solids control and separation issues.

Working principle

Separation takes place in a horizontal cylindrical bowl equipped with a screw conveyor. The feed enters the bowl through a stationary inlet tube and is accelerated smoothly by an inlet rotor. Centrifugal forces cause sedimentation of the solids on the wall of the bowl. The conveyor rotates in the same direction as the bowl, but at a different speed, thus moving the solids towards the conical end of the bowl.

The LYNX design enables the decanter to scroll out high loads of solids without blockages caused by high levels of dryness. Only the very driest fraction of the sludge cake leaves the bowl through the solids discharge openings into the casing. Separation takes place along the total length of the cylindrical part of the bowl, and the clarified liquid leaves the bowl by flowing over adjustable plate dams into the casing.



The LYNX decanter centrifuge can be adjusted to suit specific requirements by varying the bowl speed, the conveying speed, the pond depth and the feed rate.

Process optimization

The LYNX decanter centrifuge can be adjusted to suit specific requirements by varying

- the bowl speed to ensure the exact G force required for the most efficient separation.
- the conveying speed for the best possible balance between liquid clarity and solids dryness.
- the pond depth in the bowl for the best possible balance between liquid clarity and solids dryness.
- the feed rate – the LYNX is designed to handle a wide range of flow rates.

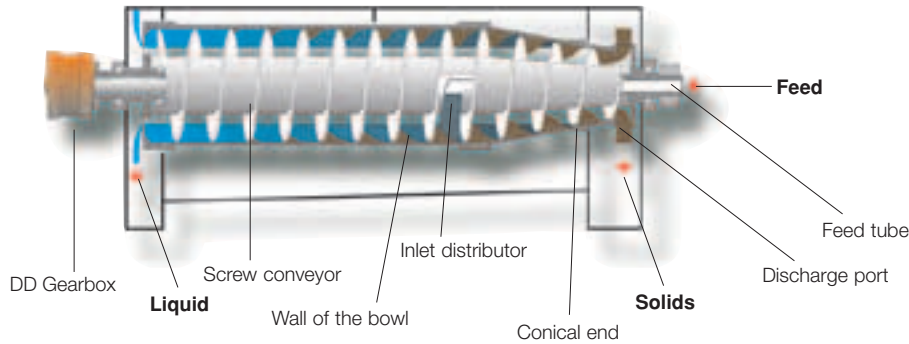

Take advantage of LYNX solids separation technology

- Maximum solids recovery
- high G Force
- newest design technologies
- specially designed decenter geometry for larger process volumes

Achieve lower cut-point and optimize your solids control and drilling process. Improve fine removal and obtain better fluid clarity. Reduce mud costs.

- Outstanding improved wear protection
- patented feed zone design for optimal flow distribution
- fully covered replaceable parts in tungsten carbide
- improved solids outlet protection

Increase the lifetime of wear parts and reduce your maintenance cycles.

- Drier solids
- optimized conveyor and bowl geometries for increased compaction capabilities

Reduce your waste volumes. Reduce your disposal costs.

- 2-Touch Control System
- easy to troubleshoot and service, ensuring maximum centrifuge uptime
- compatible with multiple industry standards and communication protocols
- consistent and has easy-to-use interfaces

Improve your operating reliability and optimize your processes. Save manpower and training costs.

- Unmatched flow rate capacity/diameter
- new generation of decenter centrifuges. Latest optimized designs
- 360-degree solids outlet

Treat larger process volumes in smaller machines and reduce your total costs per volume treated.

- Easier accessibility
- Lighter and smarter cover design
- Quick adjustable pond depth

Access easily the interior of the decenter. Optimize, service and clean faster, saving time and money.

Design

Alfa Laval designed the LYNX decenter centrifuge with a focus on performance, easy access, reliability, low power consumption and low noise levels. The rotating assembly is supported on a compact welded box beam frame with main bearings at both ends. The in-line main motor is flange- or foot mounted onto the unit with adjustable brackets for belt tension adjustment. The bowl is driven at the conical end by an electric motor with a V-belt transmission.

The bowl, conveyor, casing, inlet tube, outlets and other parts in contact with the process media are made of AISI 316 or duplex stainless steel with tungsten carbide inserts in the areas most susceptible to wear.

Direct drive

The drive system that is an integral part of the LYNX design was specially developed by Alfa Laval to make it possible to control the conveying speed automatically. This ensures the best possible balance between liquid clarity and solids dryness, irrespective of any variations that may occur in the feed flow.

The Direct Drive system comprises an exceptionally efficient gearbox and variable frequency drive, which together avoid exposing the bowl drive to parasitic braking power. It also simplifies the electrical installation and keeps power consumption and CO₂ emissions to the absolute minimum. In addition, the Direct Drive is capable of accurate control within the complete range of differentials, with no need for changing belts or pulleys.

Optional extras

- New generation of wear protection for use with extra-harsh and abrasive feeds
- A range of different power pack designs to optimize power consumption

Optional control equipment: The 2Touch control package

Each LYNX decenter centrifuge can be equipped with an Alfa Laval 2Touch control package as standard – pre-installed and factory-tested.

The combination of 2Touch control systems and LYNX separation technology ensures that you get the most out of any LYNX installation, at the same time as keeping costs for installation, commissioning, operation and maintenance to a minimum.

LYNX 300

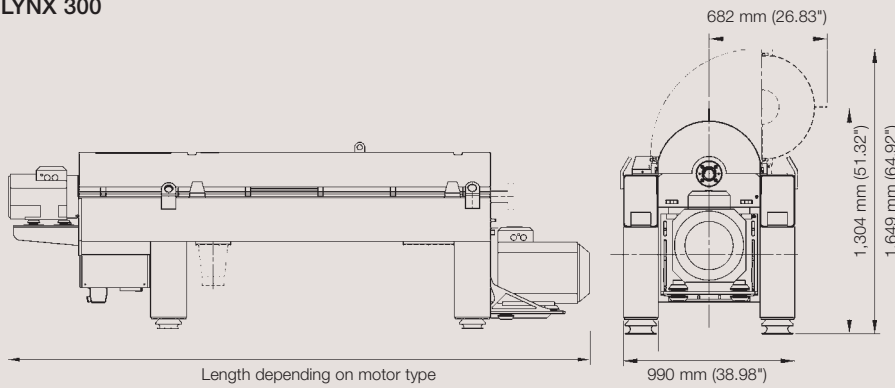

Total weight of empty decanter
2,300 kg (5,071 lbs)
Bowl dia.: 360 mm/14"
Feed rate: 60 m³/h (260 GPM)
Max. speed*: 4,200 rpm (3,550 G)
Hydraulic capacity: 70 m³/h (310 GPM)
Motor type:
NEMA: Max. length 4,191 mm (165.00")
ATEX: Max. length 4,123 mm (162.32")
2-Speed: Max. length 4,106 mm (161.65")

LYNX 400

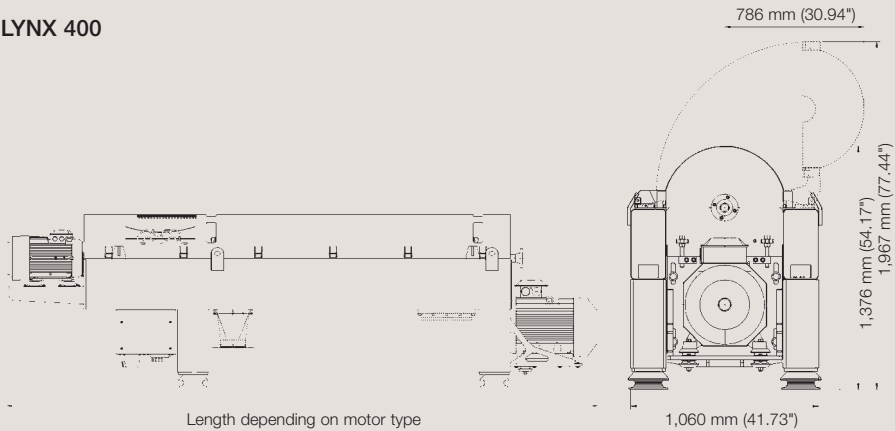

Total weight of empty decanter
3,200 kg (7,050 lbs)
Bowl dia.: 440 mm/17"
Feed rate: 93 m³/h (410 GPM)
Max. speed*: 3,800 rpm (3,550 G)
Hydraulic capacity: 120 m³/h (530 GPM)
Motor type:
NEMA: Max. length 4,736 mm (186.45")
ATEX: Max. length 4,753 mm (187.12")

LYNX 500

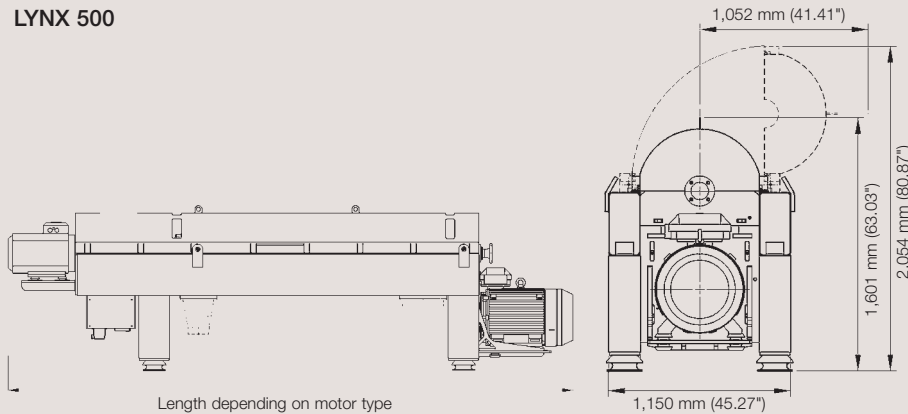

Total weight of empty decanter
4,500 kg (9,920 lbs)
Bowl dia.: 510 mm/20"
Feed rate: 132 m³/h (580 GPM)
Max. speed*: 3,250 rpm (3,011 G)
Hydraulic capacity: 150 m³/h
(660 GPM)
Motor type:
NEMA: Max. length 5,340 mm (210.23")
ATEX: Max. length 5,537 mm (218.00")

LYNX 700

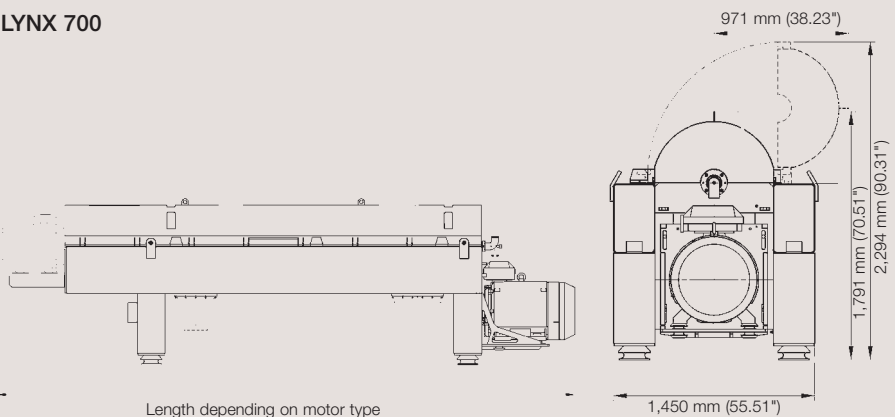

Total weight of empty decanter
6,500 kg (14,330 lbs)
Bowl dia.: 650 mm/25.6"
Feed rate: 190 m³/h (840 GPM)
Max. speed*: 3,100 rpm (3,491 G)
Hydraulic capacity: 260 m³/h (1.144 GPM)
Motor type:
NEMA: Max. length 6,312 mm (248.5")

Crash frame with full hydraulic unit

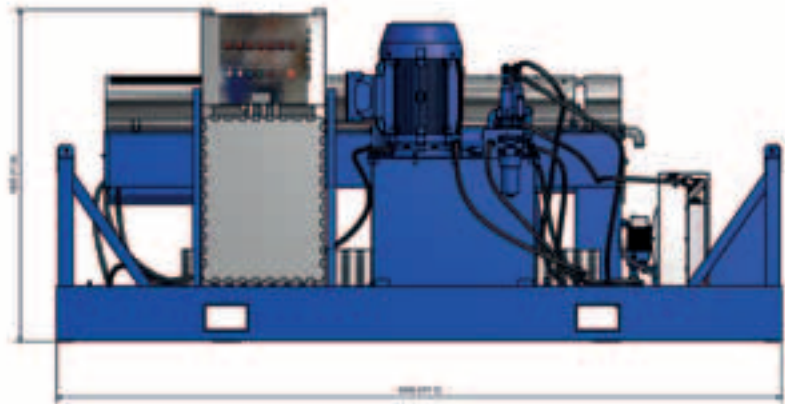
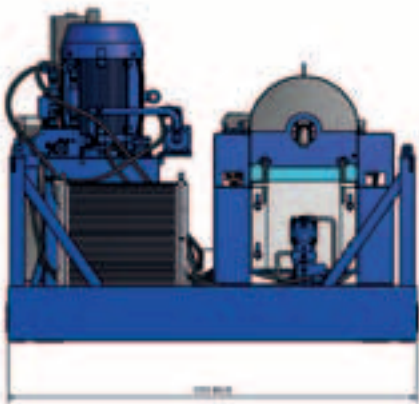
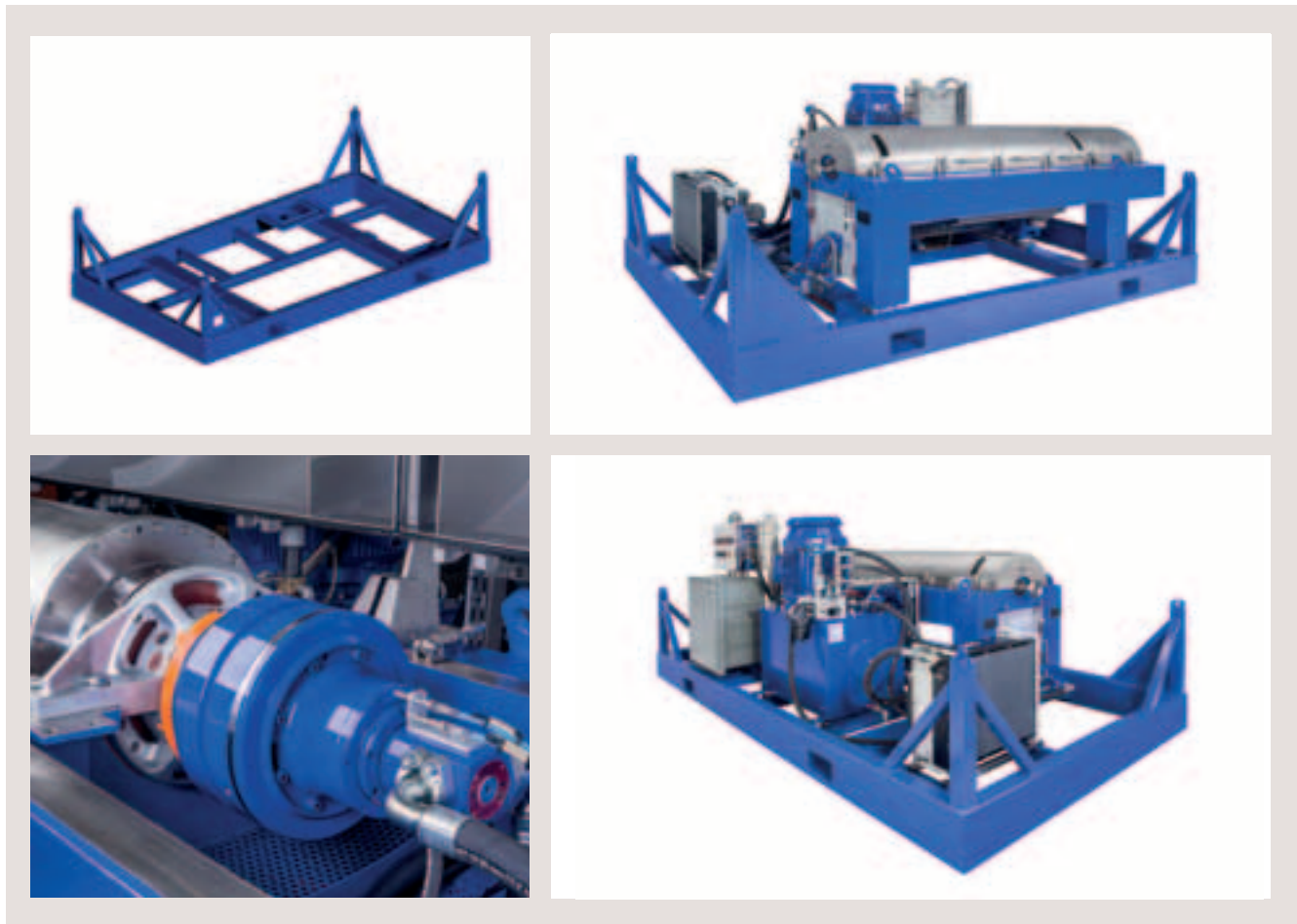

PEE00283EN 1401

Alfa Laval reserves the right to change specifications without prior notification

How to contact Alfa Laval

Up-to-date Alfa Laval contact details for all countries are always available on our website at www.alfalaval.com