

Alfa Laval MR-185S, MR-200S

Centrifugal pumps

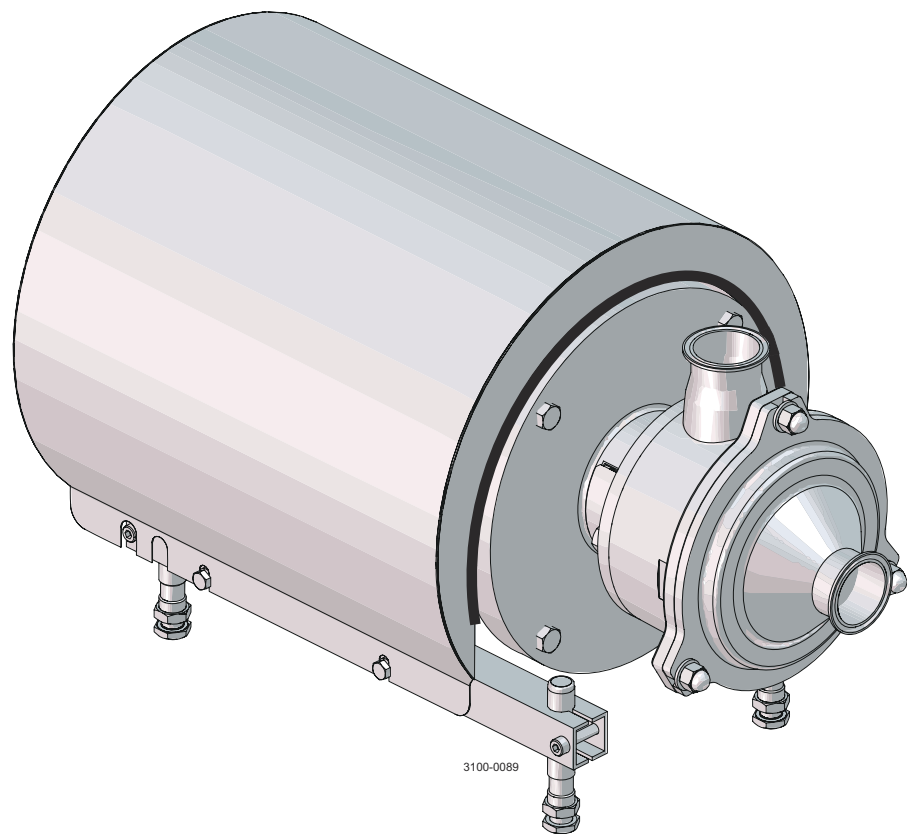

Lit. Code

200007894-1-EN-GB

Instruction Manual

Published by
Alfa Laval Kolding A/S
Albuen 31
DK-6000 Kolding, Denmark
+45 79 32 22 00

The original instructions are in English

© Alfa Laval AB 2025-08

This document and its contents are subject to copyrights and other intellectual property rights owned by Alfa Laval AB (publ) or any of its affiliates (jointly "Alfa Laval"). No part of this document may be copied, re-produced or transmitted in any form or by any means, or for any purpose, without Alfa Laval's prior express written permission. Information and services provided in this document are made as a benefit and service to the user, and no representations or warranties are made about the accuracy or suitability of this information and these services for any purpose. All rights are reserved.

Contents

1	Declarations of Conformity	5
1.1	EU Declaration of Conformity.....	5
1.2	UK Declaration of Conformity.....	6
2	Safety	7
2.1	Important Information.....	7
2.2	Safety Signs.....	8
2.3	Safety Precautions.....	10
2.4	Warning Signs in Text.....	15
2.5	Requirements of Personnel.....	16
2.6	Recycling Information.....	17
3	Introduction	19
3.1	General Information.....	19
4	Installation	21
4.1	Unpacking/Delivery.....	21
4.2	Installation.....	22
4.3	Pre-use Check.....	26
5	Operation	27
5.1	Operation/Control.....	27
5.2	Troubleshooting.....	29
5.3	Recommended Cleaning.....	30
5.3.1	Cleaning Information.....	31
6	Maintenance	33
6.1	General Maintenance.....	33
6.2	Dismantling of Pump.....	35
6.3	Assembly of Pump.....	38
7	Technical Data	41
7.1	Technical Data.....	41
7.2	Operating Data.....	42
7.3	Relubrication Intervals.....	42
7.4	Torque Specifications.....	42
7.5	Weight (kg).....	42
7.6	Noise Emission.....	43
8	Spare Parts	45
8.1	Ordering Spare Parts.....	45

8.2	Alfa Laval Service.....	45
8.3	Warranty - Definition.....	46
9	Parts Lists and Exploded Views.....	47
9.1	Drawings MR-185 / MR-200.....	47
9.2	MR - Wet end.....	48
9.3	MR - Motor dependent parts.....	49
9.4	MR - Shaft seal.....	50

1 Declarations of Conformity

1.1 EU Declaration of Conformity

The designated company

Alfa Laval Kolding A/S, Albuen 31, DK-6000 Kolding, Denmark, +45 79 32 22 00

Company name, address and phone number

Hereby declare that

Pump

Designation

MR-185S, MR-200S

Type

AAB000000001-AAB999999999, AAX000000001-AAX999999999, 10.000-1.000.000, 100700000001-100799999999

Serial number

is in conformity with the following directives with amendments:

- Machinery Directive 2006/42/EC
- RoHS Directive 2011/65/EU and amendments

The person authorised to compile the technical file is the signer of this document.

Vice President BU Hygienic Fluid Handling

Head of Product Management

Title

Mikkel Nordkvist

Name

Kolding, Denmark

Place

2025-08-01

Date (YYYY-MM-DD)



Signature

DoC Revison_ 01_082025 / This Declaration of Conformity replaces Declaration of Conformity dated 2022-10-01



1.2 UK Declaration of Conformity

The designated company

Alfa Laval Kolding A/S, Albuen 31, DK-6000 Kolding, Denmark, +45 79 32 22 00

Company name, address and phone number

Hereby declare that

Pump

Designation

MR-185S, MR-200S

Type

AAB000000001-AAB999999999, AAX000000001-AAX999999999, 10.000-1.000.000, 100700000001-100799999999

Serial number

is in conformity with the following directives with amendments:

- The Supply of Machinery (Safety) Regulations 2008
- The Restriction of the Use of Certain Hazardous Substances in Electrical and Electronic Equipment Regulations 2012

Signed on behalf of: Alfa Laval Kolding A/S.

Vice President BU Hygienic Fluid Handling
Head of Product Management

Title

Mikkel Nordkvist

Name

Kolding, Denmark

Place

2025-08-01

Date (YYYY-MM-DD)





Signature

DoC Revison_ 02_082025



2 Safety

Read this first

 	<p>This Instruction Manual is designed for operators and service engineers working with the supplied Alfa Laval product.</p> <p>Operators must read and understand the Safety, Installation and Operating instructions of the supplied Alfa Laval product before carrying out any work or before you put the supplied Alfa Laval product into service!</p> <p>Not following the instructions can result in serious accidents.</p> <p>This documentation describes the authorized way to use the supplied Alfa Laval product. Alfa Laval will take no responsibility for injury or damage if the equipment is used in any other way.</p> <p>This Instruction Manual is designed to provide the user with the information to perform tasks safely for all phases in the lifetime of the supplied Alfa Laval product.</p> <p>The operator shall always read the chapter Safety first. Hereafter the operator can skip to the relevant section for the task to be carried out or for the information needed.</p> <p>Always read the chapter Technical Data thoroughly.</p> <p>This is the complete Instruction Manual for the supplied Alfa Laval product.</p>
--	--

NOTE

The illustrations and specifications in this Instruction Manual were effective at the date of printing. However, as continuous improvements are our policy, we reserve the right to alter or modify the Instruction Manual without prior notice or any obligation.

The English version of the Instruction Manual is the original manual. Alfa Laval cannot be held responsible for incorrect translations. In case of doubt, the English version applies.

2.1 Important Information

NOTE

Always read the manual before using the pump!

This Instruction Manual is designed to provide the user with the information to perform tasks safely for all phases in the life time of the product supplied.

The User shall **always** read the safety chapter first. Hereafter the User can skip to the relevant section for the task to be carried out or for the information needed.

This is the complete manual for the supplied product.

2.2 Safety Signs

Mandatory Action Signs

	General mandatory action sign.
	Refer to instruction manual.
	Use ear protection in noisy environments - noise protector.
	Use eye protection - safety glasses.
	Wear protective equipment - safety shoes.
	Use protective hand wear - safety gloves.
	Wear protective equipment - safety helmet.

Warning Signs

	General warning.
	Electricity.
	Transportation with forklift truck or other industrial vehicles if heavy.
	Heavy object lifting.
	Hot surface and burning danger.
	Sharp element.
	Crushing of hands.
	Corrosive substance.





2.3 Safety Precautions

All warnings in the manual are summarised on this page. Pay special attention to the instructions below so that severe personal injury and/or damage to the Supplied Alfa Laval Product is avoided.





General



	<p>Technical data must be observed during installation, operation and maintenance.</p> <p>All personnel should be informed about the technical data.</p> <p>The rules of Intended use are absolute. Use of the supplied Alfa Laval product is allowed only when in compliance with the technical data supplied with the Intended use.</p> <p>Differing utilisation, other than agreed with Alfa Laval Kolding A/S, exclude any liability and warranty.</p> <p>No modification or alteration of the supplied Alfa Laval product is allowed, unless explicit permission is granted by Alfa Laval Kolding A/S.</p>
---	---

Transportation and Lifting





  	<p>Never lift or elevate in any way other than described in this manual.</p> <p>Always use the original packaging or similar during transportation.</p> <p>Always ensure that personnel must have experience with lifting operations.</p> <p>Always transport the pump in its upright position.</p> <p>Always drain the pump head and accessories of any liquid.</p>
 	<p>Always ensure that the unit is securely fixed during transportation.</p> <p>Always ensure the lifting point to be in line with center of gravity. Adjust lifting point if necessary.</p> <p>Always use suitable transport device ie. forklift or pallet lifter.</p> <p>Always use appropriate lifting equipment for heavy parts when relevant.</p> <p>Always keep an eye on the load and stay clear during the lifting operation.</p>

Installation





	<p>If the local safety regulations prescribe that the installation has to be inspected and approved by responsible authorities before the supplied Alfa Laval product is put into service, consult with such authorities before installing the equipment and have the projected installation approved by them.</p> <p>Always read the <i>Technical Data</i> on page 41 thoroughly.</p> <p>Always check the pump before operation. See <i>Pre-use Check</i> on page 26.</p> <p>Check the direction of rotation of the impeller before operation. See the indication label on the pump.</p> <p>Always remove the impeller before checking the direction of rotation.</p> <p>Stay clear and ensure no one is near the shaft during test of rotation.</p> <p>Never start in the wrong direction of rotation with liquid in the pump.</p> <p>The large pump sizes are very heavy. Always use appropriate lifting equipment when handling the pump.</p> <p>Alfa Laval cannot be held responsible for incorrect unpacking.</p> <p>Alfa Laval cannot be held responsible for incorrect installation.</p> <p>Be aware that certain pump configurations can tilt, and therefore cause injuries to feet or fingers. The pump should be supported underneath the adaptor, when not installed in the process line.</p> <p>In case of shaft seal leakage, the media will drip from the slot in the bottom of the adaptor. In case of shaft seal leakage, Alfa Laval recommends putting a drip tray underneath the slot to collect the leakage.</p> <p>The 3A standard requires minimum clearance between the lowest part of the base, pump, motor or drive and for the floor to be no less than 100 mm / 4".</p> <p>The pump does not prevent back flow when intentionally or unintentionally stopped. If back flow can cause any hazardous situations, precautions must be taken e.g. a check valve can be installed in the system preventing hazardous situations.</p> <p>If the pump has been stored for longer period of time there is a risk that the seal faces may stick together and consequently cause damage to the seal at start-up. Please ensure that the pump shaft can be rotated by hand before start-up.</p>
	<p>Never start the pump if the impeller is fitted and the pump casing is removed.</p>
	<p>Always use a lifting crane when handling the pump.</p>
	<p>Always ensure all pipe lines (product, air, and water) are depressurized and emptied before installation, inspection, assembling and disassembling.</p>

	<p>Always have the pump electrically connected by authorised personnel. (See the motor instructions).</p> <p>Alfa Laval recommends the installation of a lockable repair breaker. If the repair breaker is to be used as an emergency stop, the colours of the repair breaker must be red and yellow.</p> <p>Alfa Laval recommends the supply disconnecting device shall be in accordance with EN60204-1. Always disconnect the supply disconnecting device safely after installation before continuing the installation.</p>
	<p>Always ensure the adaptor shield and motor fan guard are present and mounted correctly and allow no access to rotating parts before installing and starting the pump.</p>

Operation

	<p>Always read the Technical Data on page 41 thoroughly.</p> <p>Never run the pump when partially installed or not completely assembled.</p> <p>Necessary precautions must be taken if leakage occurs as this can lead to hazardous situations.</p> <p>Never use the pump for products not mentioned in the Alfa Laval pump selection program.</p> <p>The Alfa Laval pump selection program can be acquired from your local Alfa Laval sales company.</p> <p>Study the instructions carefully and pay special attention to the warnings!</p> <p>Alfa Laval cannot be held responsible for incorrect operation/control.</p> <p>The shaft seal must not run dry.</p> <p>Never throttle the inlet side.</p> <p>The supplied product is designed for cleaning in place (CIP). Use clean water free from chlorides.</p>
	<p>Never run the pump with both the suction side and the pressure side blocked.</p>
	<p>Never touch the supplied product or the pipelines when processing hot liquids or sterilizing.</p> <p>If pumps are sterilised using steam, standard 3A requires the process system to be designed to automatically shut down if the product pressure in the system becomes less than of the atmosphere and it cannot be started until the system is re-sterilised.</p>
	<p>Always follow the instructions in the safety data sheet for the cleaning agent.</p> <p>Always handle lye and acid with great care.</p> <p>The cleaning agents must be stored/disposed of in accordance with current regulations and directives.</p> <p>Always rinse well with clean water after the cleaning.</p>

Maintenance

	<p>In order to optimise the operation of the supplied Alfa Laval product and to minimize the down time due repair activities, the maintenance should consist of:</p> <ul style="list-style-type: none"> • Inspection and maintenance of the supplied Alfa Laval product: strictly follow the technical documentation • Preventive maintenance: visual inspection of the supplied Alfa Laval product followed by necessary adjustments and planned periodic replacement of wear and tear parts • Repairs: unscheduled break-down of a component, often causing the system to stop. Damaged components shall be replaced or repaired • Stock of Alfa Laval genuine spare parts: Alfa Laval recommend keeping a stock of genuine spare parts facilitating preventive maintenance and reducing down time in case of unplanned break-downs <p>Always read the <i>Technical Data</i> on page 41 thoroughly.</p> <p>Never service the pump if pressurised.</p> <p>Always use Alfa Laval genuine spare parts.</p> <p>Motors with grease nipples:</p> <p>Always lubricate according to motor manufactures recommended procedures.</p> <p>Always locate and remove grease vent plugs, if provided, prior to adding grease.</p> <p>Always check motor nameplate for grease type and lubrication intervals.</p> <p>Only use the grease type specified on the motor name plate.</p> <p>For Motor Maintenance, see motor instruction manual.</p> <p>Maintain the pump carefully.</p> <p>Study the instructions carefully and pay special attention to the warnings!</p> <p>Always keep spare shaft seals and rubber seals in stock.</p> <p>Check the pump for smooth operation after service.</p> <p>All scrap must be stored/disposed of in accordance with current regulations and directives.</p> <p>If the pump is supplied with FEP O-rings. Alfa Laval recommends that the casing O-ring is replaced during pump maintenance.</p> <p>If pump is not supplied with flush connections, the holes in the adaptor must be covered by the guard.</p>
	<p>Never service the pump when it is hot.</p>
	<p>Always disconnect the power supply when servicing the pump.</p> <p>Fit the electrical connections correctly if they have been removed from the motor during service.</p>
	<p>Always follow the instructions in the safety data sheets from the suppliers of cleaning agents, detergents, oils etc.</p> <p>Always follow the instructions in the safety data sheet for the cleaning agent.</p>

Storage



Alfa Laval recommend:

- Store the supplied Alfa Laval product as supplied in original packaging
- Port opening(s) should be protected against any ingress
- Bare steel (not stainless) should be lightly oiled/greased
- Store in a clean, dry place without direct sunlight or UV light
- Temperature range -5 °C to +40 °C / +23 °F to +104 °F
- Relative humidity less than 60%
- No exposure to corrosive substances (including contained air)

Noise



Under certain operating conditions, the supplied Alfa Laval product and/or the systems in which they are installed can produce high sound pressure levels. Appropriate noise protection measures should be taken when necessary and in accordance with local legislation.

Safety check



A visual inspection of any protective device (shield, guard, cover or other) on the supplied Alfa Laval product shall be carried out at least every 12 months. If the protective device is lost or damaged, especially when this leads to deterioration of safety performance, it shall be replaced. The fixing of the protective device should only be replaced with fixings of the same or an equivalent type.

Inspection acceptance criteria:

- It should not be possible to reach moving parts originally protected by a protective device
- The protective device must be securely mounted
- Ensure that screws for the protective device are securely tightened

Procedure in case of non-acceptance:

- Fix and/or replace the protective device

2.4 Warning Signs in Text

Pay attention to the safety instructions in this Instruction Manual.

Below are definitions of the four grades of warning signs used in the text where there is a risk for injury to personnel or damage to the supplied Alfa Laval product.

**DANGER**

Indicates an imminently hazardous situation which, if not avoided, will result in death or serious injury.

**WARNING**

Indicates a potentially hazardous situation which, if not avoided, could result in death or serious injury.

**CAUTION**

Indicates a potentially hazardous situation which, if not avoided, may result in minor or moderate damage to the supplied Alfa Laval product.

**NOTE**

Indicates important information to simplify or clarify procedures.

2.5 Requirements of Personnel

Operators

The operators shall read and understand this Instruction Manual.

Maintenance personnel

The maintenance personnel shall read and understand this Instruction Manual. The maintenance personnel or technicians shall be skilled within the field required to carry out the maintenance work safely.

Trainees

Trainees can perform tasks under the supervision of an experienced employee.

People in general

The public shall not have access to the supplied Alfa Laval product.

In some cases, specially skilled personnel may need to be hired (i.e. electricians, welders). In some cases the personnel has to be certified according to local regulations with experience of similar types of work.

2.6 Recycling Information

Unpacking

Packing material may consist of wood, plastics, cardboard boxes and in some cases metal straps.



- Wood and cardboard boxes can be reused, recycled or used for energy recovery
- Plastics should be recycled or burnt at a licensed waste incineration plant
- Metal straps should be sent for material recycling

Maintenance

During maintenance, oil (if used) and wear parts in the supplied Alfa Laval product should be replaced.

- Oil and all non-metal wear parts must be disposed of in accordance with local regulations
- Rubber and plastics should be burnt at a licensed waste incineration plant. If not available they should be disposed of in accordance with local regulations
- Bearings and other metal parts should be sent to a licensed handler for material recycling
- Seal rings and friction linings should be disposed of to a licensed land fill site. Check your local regulations
- All metal parts should be sent for material recycling
- Worn out or defected electronic parts should be sent to a licensed handler for material recycling

Scrapping

At end of use, the equipment must be recycled in accordance with the relevant local regulations. Besides the equipment itself, any hazardous residues from the process liquid must be considered and dealt with in a proper manner. When in doubt, or in the absence of local regulations, please contact your local Alfa Laval sales company.

How to contact Alfa Laval

Contact details for all countries are continually updated on our website.

Please visit www.alfalaval.com to access the information directly.

This page is intentionally left blank.

3 Introduction

The Alfa Laval MR is a well proven liquid-ring pump specifically developed for effective pumping of liquids with entrained air. The construction of the MR makes it perfectly suited for use as a return pump in CIP systems.

3.1 General Information

MR is a liquid-ring pump specially designed for pumping liquids containing air or gas.

The pump is for use in the food, chemical, pharmaceutical and similar industries.

The pump is mainly used for CIP-return application.

The pump is available in the following sizes, MR-185S and MR-200S.

This page is intentionally left blank.

4 Installation

4.1 Unpacking/Delivery

⚠ WARNING

Be aware that certain pump configurations can tilt, and therefore cause injuries to feet or fingers. The pump should be supported underneath the adaptor, when not installed in the process line.

⚠ CAUTION

Alfa Laval cannot be held responsible for incorrect unpacking.

Always use a lifting crane when handling the pump.

! NOTE

The large pump sizes are very heavy. **Always** use appropriate lifting equipment when handling the pump.

Check the delivery for:

- Complete pump
- Delivery note
- Motor instructions

- 1 Remove any packing materials from the inlet and the outlet.

Avoid damaging the inlet and the outlet.

Avoid damaging the connections for flushing liquid, if supplied.

*) Remove packing materials!

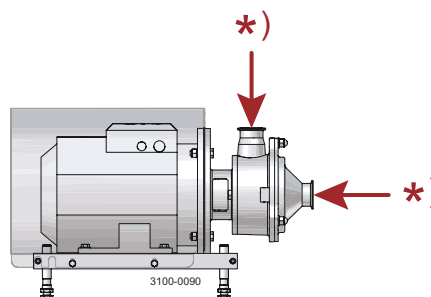

- 2 Inspect the pump for visible transport damage.

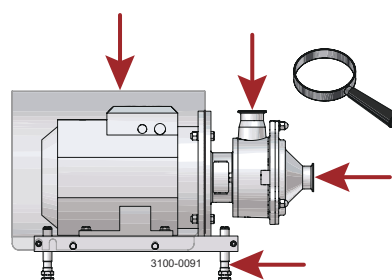

- 3 Always remove the shroud, if fitted, before lifting the pump.

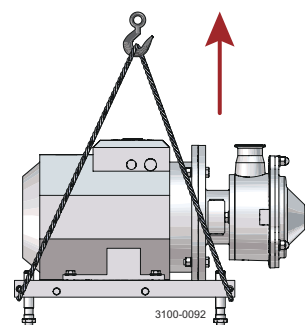

4.2 Installation

! WARNING

Always have the pump electrically connected by authorised personnel. (See the motor instructions).

Alfa Laval recommends the installation of a lockable repair breaker. If the repair breaker is to be used as an emergency stop, the colours of the repair breaker must be red and yellow.

Alfa Laval recommends the supply disconnecting device shall be in accordance with EN60204-1. Always disconnect the supply disconnecting device safely after installation before continuing the installation.



! CAUTION

Alfa Laval cannot be held responsible for incorrect installation.

Always use a lifting crane when handling the pump.

The pump does not prevent back flow when intentionally or unintentionally stopped. If back flow can cause any hazardous situations, precautions must be taken e.g. a check valve can be installed in the system preventing hazardous situations.

If the pump has been stored for longer period of time there is a risk that the seal faces may stick together and consequently cause damage to the seal at start-up. Please ensure that the pump shaft can be rotated by hand before start-up.

! NOTE

Study the instructions carefully and pay special attention to the warnings!

Always read the [Technical Data](#) on page 41 thoroughly.

Always check the pump before operation. See [Pre-use Check](#) on page 26.

The large pump sizes are very heavy. **Always** use appropriate lifting equipment when handling the pump.

In case of shaft seal leakage, the media will drip from the slot in the bottom of the adaptor. In case of shaft seal leakage, Alfa Laval recommends putting a drip tray underneath the slot to collect the leakage.

- 1 Ensure at least 0.5 m /1.6' clearance around the pump.

Ensure the floor/frame is able to support the weight of the pump. See [Technical Data](#) on page 41.

Ensure the pump is supported by all four feet equally.

DO NOT fixate the motor and/or leg bracket to floor and/or frame.

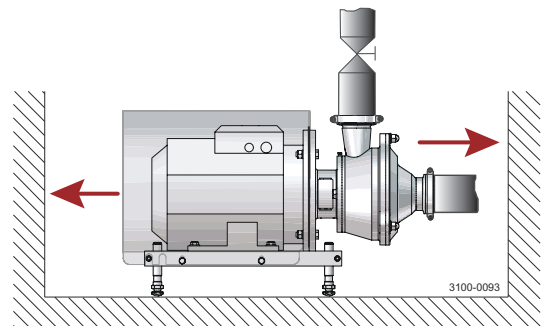

2 Check that the flow direction is correct.

O: Outlet

I: Inlet

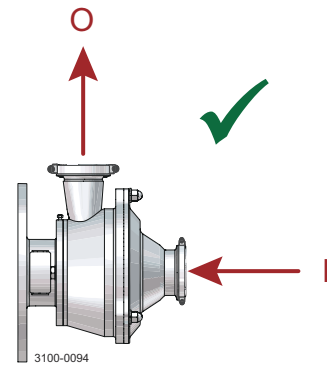

- 3
- Ensure that the pipelines are routed correctly.
 - Ensure that the connections are tight.
 - Remember seal rings. Few bends.

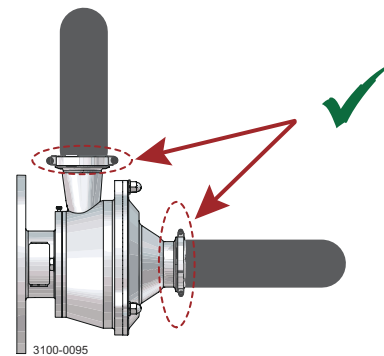

4 Avoid stress on the pump.
Piping system must be self-supported.

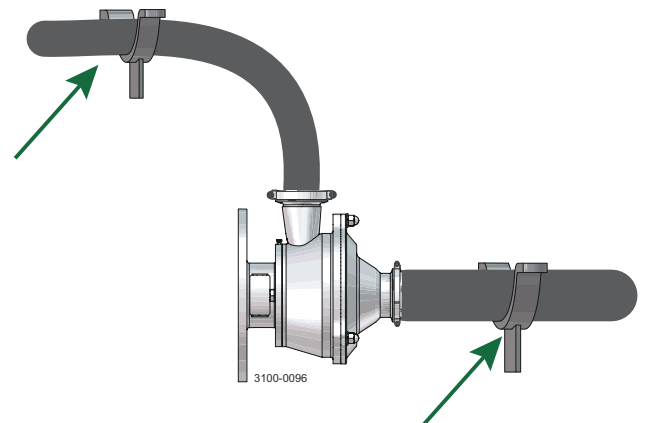

Pay special attention to:

- Vibrations
- Thermal expansion of the tubes
- Excessive welding
- Overloading of the pipelines

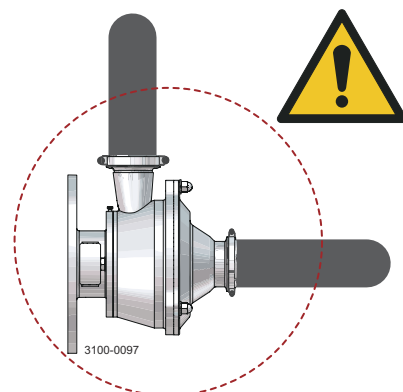

- 5 Ensure correct alignment of pump inlet and outlet with piping system.

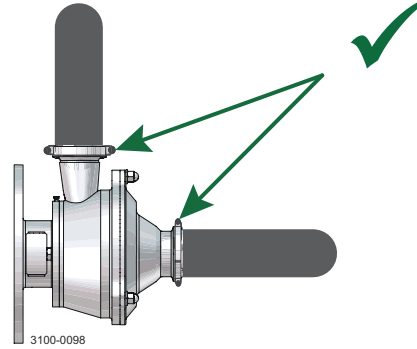

Alignment can be done by adjusting the pump legs.

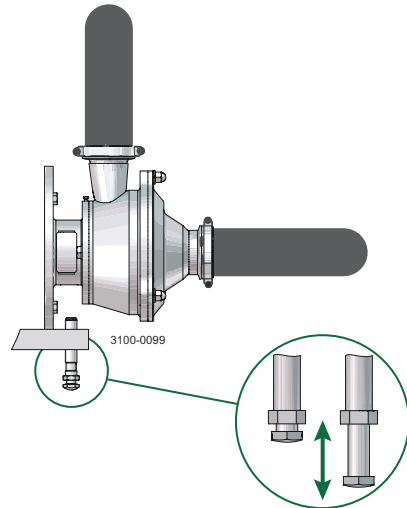

Centre of inlet and outlet to be aligned with centre of piping system.

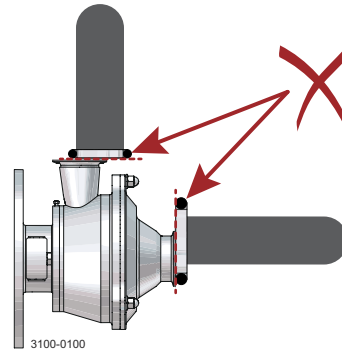

No gaps between connections on pump inlet and inlet pipe, and pump outlet and outlet pipe.

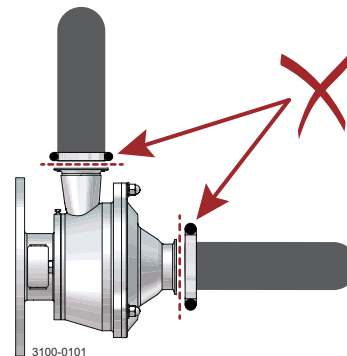

Angle between connections on pump inlet and inlet pipe, pump outlet and outlet pipe not allowed.

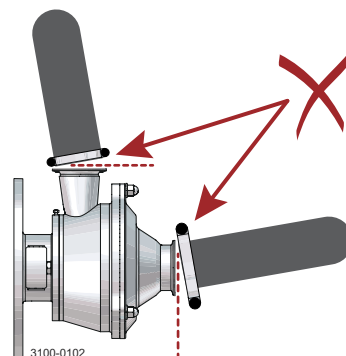

- 6 Ensure correct alignment of pump casing and pump backplate.

Angle not allowed.

Alignment can be done by adjusting the pump legs.

Ensure stud bolts in casing are aligned with holes in backplate.



Always ensure the adaptor shield and motor fan guard are present and mounted correctly and allow no access to rotating parts before installing and starting the pump.

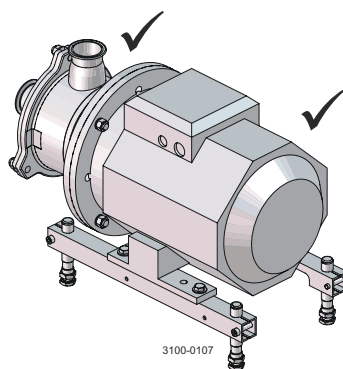

4.3 Pre-use Check

NOTE

Study the instructions carefully and pay special attention to the warnings!

Check the direction of rotation of the impeller before operation. See the indication label on the pump.

WARNING

Never start the pump if the impeller is fitted and the pump casing is removed.



CAUTION

Never start in the wrong direction of rotation with liquid in the pump.

1

- a) Connect power supply.
- b) Start and stop the motor momentarily.
- c) Ensure that the direction of rotation of the motor fan is **clockwise** as viewed from the rear end of the motor.
- d) Disconnect power supply safely.

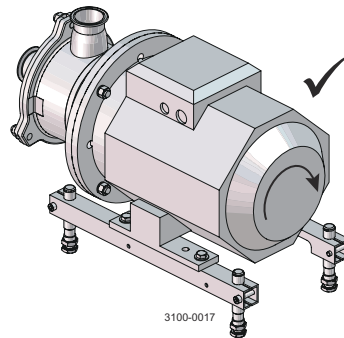

5 Operation

5.1 Operation/Control

NOTE

Study the instructions carefully and pay special attention to the warnings!

Always read the *Technical Data* on page 41 thoroughly.

DANGER Explosion danger!

Never run the pump with both the suction side and the pressure side blocked.

See the warning label!

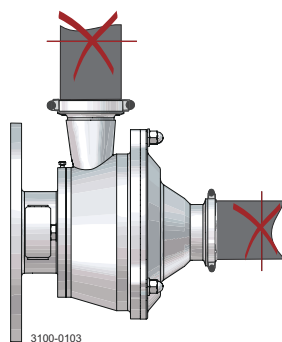

DANGER Rotating parts!

Never stick your fingers or any tool through the adaptor or the drain hole in the pump casing when the pump is running.

WARNING Burning risk!

Never touch the supplied product or the pipelines when processing hot liquids or sterilizing.

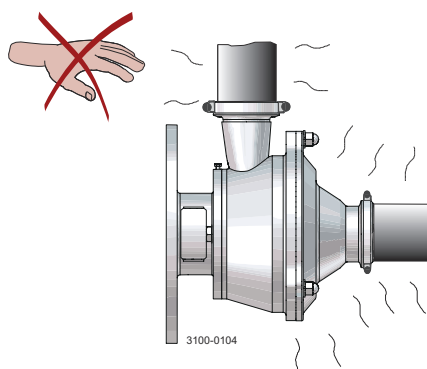

CAUTION

The shaft seal must not run dry.

Never throttle the inlet side.

*) **Do not allow to run dry**

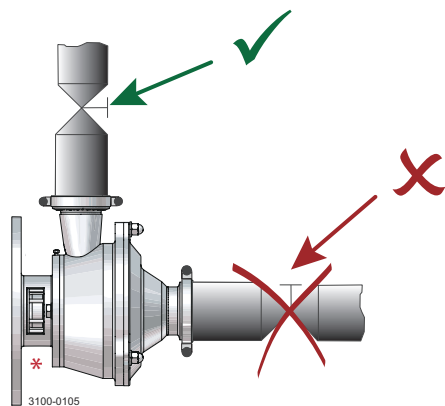
**CAUTION**

Alfa Laval cannot be held responsible for incorrect operation/control.

Control

Reduce the capacity by means of:

- Throttling the pressure side of the pump
- speed control of the motor

5.2 Troubleshooting

NOTE

Read the maintenance instructions carefully before replacing worn parts.

Problem	Cause/result	Remedy
Overloaded Motor	Pumping of viscous liquids	Larger motor
	Pumping of high density liquids	
	High outlet pressure (counter pressure)	Decrease counter pressure
	Lamination of precipitates from the liquid	Frequent cleaning
Leaking shaft seal	<ul style="list-style-type: none"> • Dry run • Incorrect rubber grade • Abrasive particles in the liquid 	Replace all wear parts If necessary: <ul style="list-style-type: none"> • Change rubber grade • Change seal face material
Leaking O-ring seals	<ul style="list-style-type: none"> • Incorrect rubber grade • Aged O-ring 	Change rubber grade

5.3 Recommended Cleaning

⚠ WARNING Risk of burns!

Never touch the supplied product or the pipelines when sterilizing.



⚠ CAUTION

Always handle lye and acid with great care.



! NOTE

The supplied product is designed for cleaning in place (CIP).

NaOH = Caustic soda.

HNO₃ = Nitric acid.

The cleaning agents must be stored/disposed of in accordance with current regulations/directives.

Examples of cleaning agents

! NOTE

Use clean water free from chlorides.

Metric System

1. 1% by weight NaOH at 70°C

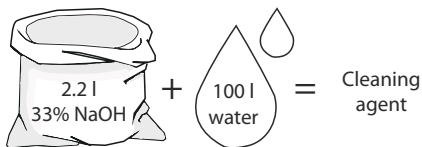
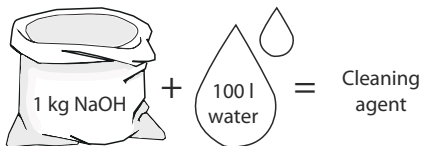

2. 0.5% by weight HNO₃ at 70°C

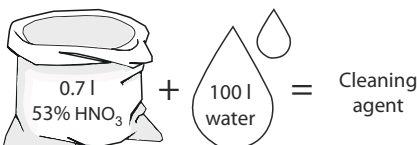

Imperial System

1. 1% by weight NaOH at 158°F

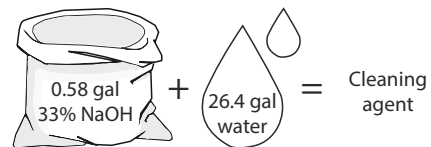
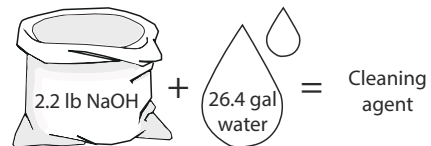

2. 0.5% by weight HNO₃ at 158°F

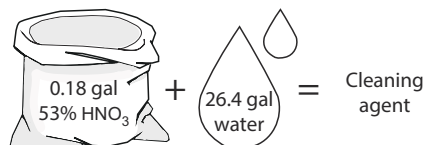

1. Avoid excessive concentration of the cleaning agent ⇒ **Dose gradually!**
2. Adjust the cleaning flow to the process
Milk sterilization/viscous liquids ⇒ Increase the cleaning flow!



Always rinse well with clean water after the cleaning.

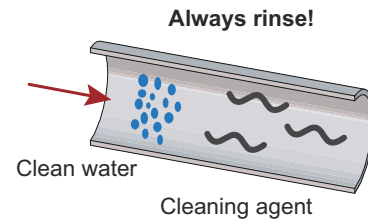

5.3.1 Cleaning Information



If pumps are sterilised using steam, standard 3A requires the process system to be designed to automatically shut down if the product pressure in the system becomes less than of the atmosphere and it cannot be started until the system is re-sterilised.

This page is intentionally left blank.

6 Maintenance

6.1 General Maintenance

NOTE

Maintain the pump carefully.

Study the instructions carefully and pay special attention to the warnings!

For motor maintenance, see motor instruction manual.

Always read the *Technical Data* on page 41 thoroughly.

Always keep spare shaft seals and rubber seals in stock.

Check the pump for smooth operation after service.

All scrap must be stored/disposed of in accordance with current regulations and directives.

DANGER

Never service the pump if pressurised.

*Atmospheric pressure required!

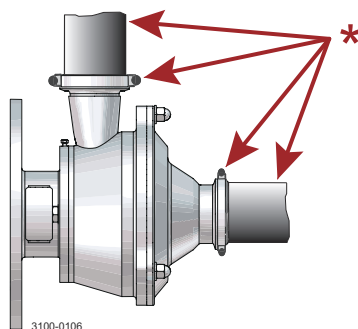

WARNING

Burning risk!

Never service the pump when it is hot.

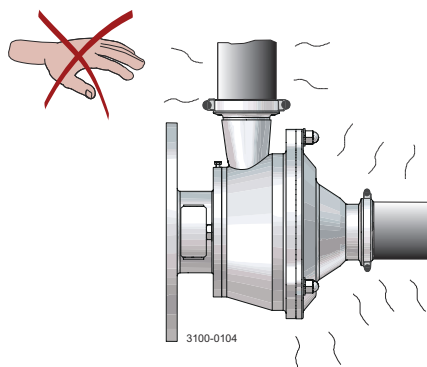



Always disconnect the power supply when servicing the pump.

Fit the electrical connections correctly if they have been removed from the motor during service.



	Shaft seal	Rubber seals	Motor bearings
Preventive maintenance	Replace after 12 months: (one-shift) Complete shaft seal.	Replace when replacing the shaft seal.	
Maintenance after leakage (leakage normally starts slowly)	Replace at the end of the day: Complete shaft seal.	Replace when replacing the shaft seal.	
Planned maintenance	<ul style="list-style-type: none"> Regular inspection for leakage and smooth operation Keep a record of the pump Use the statistics for planning of inspections Replace after leakage: Complete shaft seal.	Replace when replacing the shaft seal.	Yearly inspection is recommended <ul style="list-style-type: none"> Replace complete bearing if worn Ensure that the bearing is axially locked (See motor instructions)
Lubrication	Before fitting: Lubricate the O-rings with silicone grease or silicone oil.	Before fitting: Lubricate with silicone grease or silicone oil.	See information on motor name plate.

Pre-use Check

See *Pre-use Check* on page 26

6.2 Dismantling of Pump

NOTE

Study the instructions carefully and pay special attention to the warnings!

The items refer to *Parts Lists and Exploded Views* on page 47.

- 1 Remove screws (34), shroud (31) and distance sleeve (42).

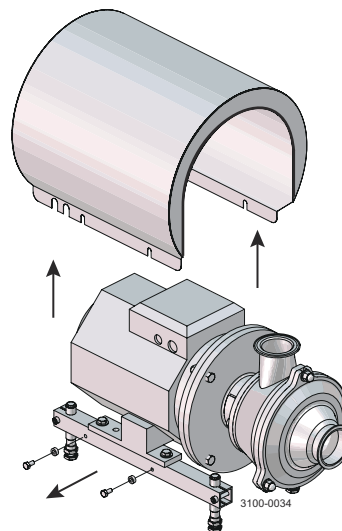

- 2 Remove covers (2a)

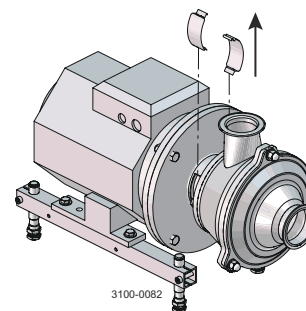

- 3 Remove cap nuts (14), washers (15a) and casing cover (10).

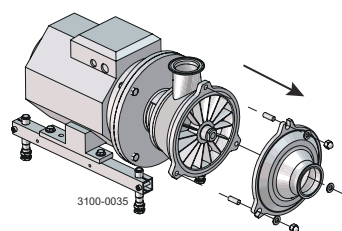

- 4 Remove O-ring (8) from pump casing (9).

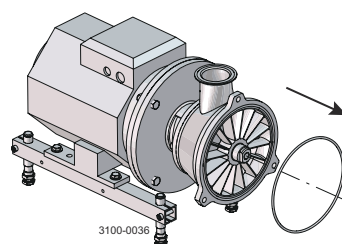

- 5 a) Remove impeller nut (13) anti-clockwise, (counterhold stub shaft (3)).
 b) Remove impeller (11) from the stub shaft.

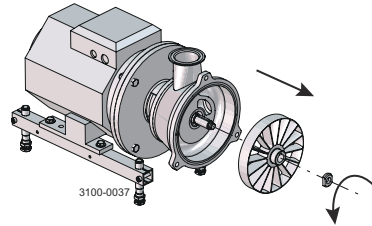

- 6 Remove key (12) from stub shaft (3) using a pair of pliers.

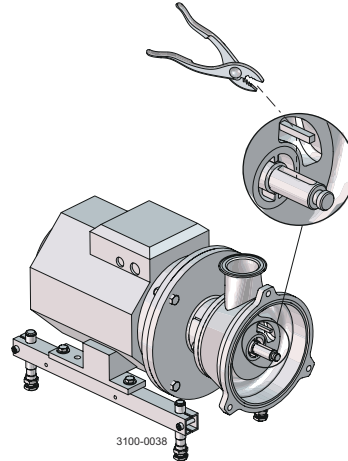

- 7 Turn stationary seal ring (28) clockwise and remove it from pump casing (9) (use the tool supplied).

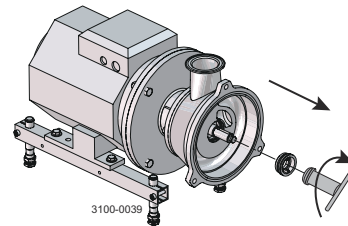

- 8 Remove O-ring (30) from stationary seal ring (29).

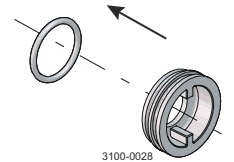

- 9 Remove rotating seal ring (27), spring (25) and O-ring (26) from stub shaft (3).

NOTE

If necessary, place a screwdriver through the hole in pump casing (9) and push the seal parts out.

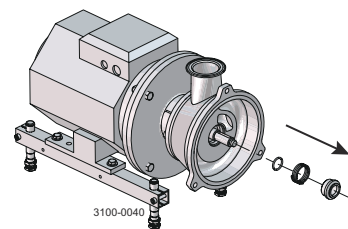

- 10 a) Remove screws (6) and washers (7).
 b) Remove adaptor (2) together with pump casing (9).

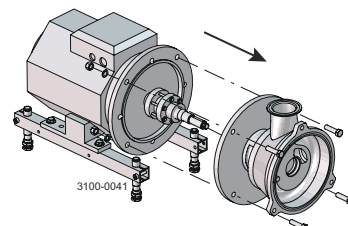

- 11**
- Remove screws (16) and washers (17).
 - Remove pump casing (9) from adaptor (2).

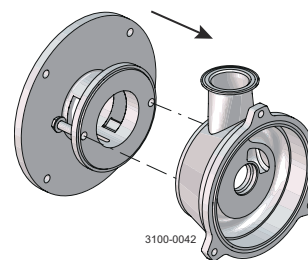

- 12** Remove thrower (24) from stub shaft (3).

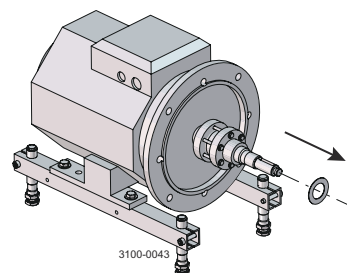

- 13**
- Loosen screws (5).
 - Remove stub shaft (3) together with compression rings (4a+b).

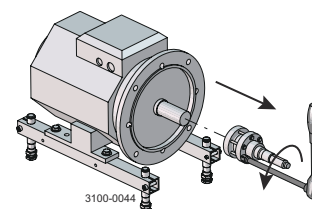

- 14** Remove screws (5), washer (5a) and compression rings (4a+b) from stub shaft (3).

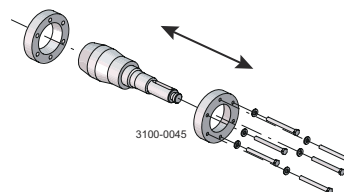

6.3 Assembly of Pump

NOTE

Study the instructions carefully and pay special attention to the warnings!

The items refer to *Parts Lists and Exploded Views* on page 47.

- 1 Fit compression rings (4a+b), screws (5) and washer (5a) correctly on stub shaft (3).

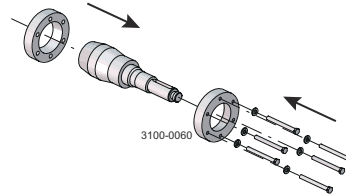

- 2 a) Fit stub shaft (3) on the motor shaft.
b) Check the clearance between the end of the stub shaft and the motor flange (10-20 mm)

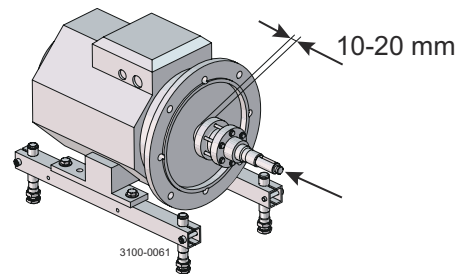

- 3 a) Tighten screws (5) lightly and evenly.
b) Ensure that stub shaft (3) can be moved on the motor shaft.

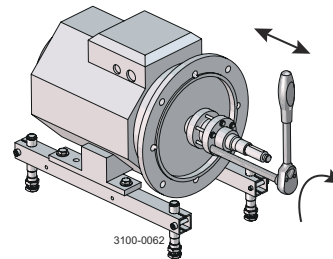

- 4 a) Fit pump casing (9) on adaptor (2).
b) Fit washers (17) and screws (16).
c) Tighten the screws.

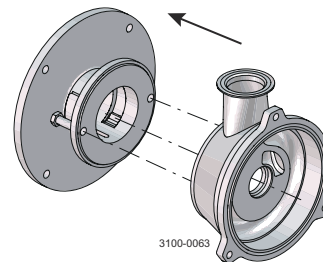

- 5 a) Fit adaptor (2) on the motor.
b) Fit washers (7) and screws (6).
c) Tighten the screws.

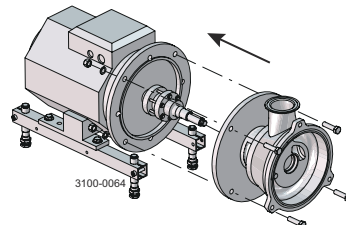

- 6**
- Fit impeller (11) on stub shaft (3).
 - Fit impeller nut (13) clockwise on the shaft and tighten lightly.

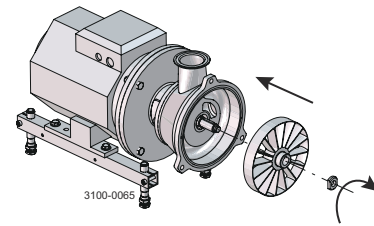

- 7**
- Ensure that the clearance between impeller (11) and pump casing (9) is 0.15-0.20 mm (tap gently with a plastic hammer).

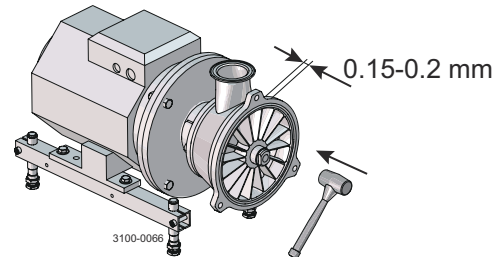

- 8**
- Remove impeller (11), pump casing (9) and adaptor (2) without moving stub shaft (3) on the motor shaft.

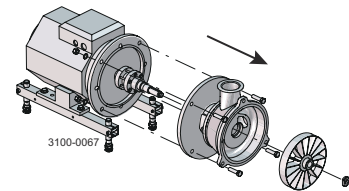

- 9**
- Torque tighten screws (5) evenly to 15 Nm (counterhold stub shaft (3)).

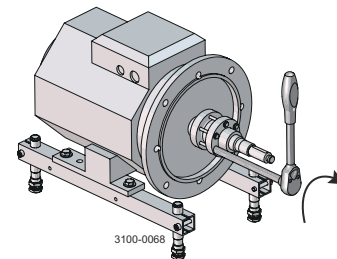

- 10**
- Fit thrower (24) on stub shaft (3).
 - Fit adaptor (2) together with pump casing (9) on the motor.
 - Fit washers (7) and screws (6).

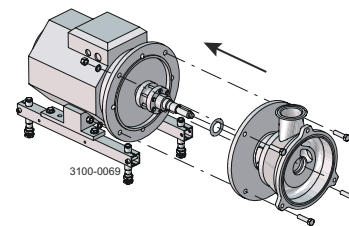

- 11**
- Lubricate O-ring (26) and push it on stub shaft (3) and position it correctly.
 - Place spring (25) on rotating seal ring (27).
 - Push the seal ring over the O-ring as far as possible against the shoulder.

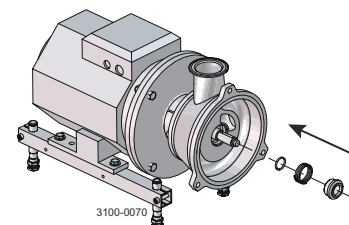

- 12**
- Fit O-ring (29) on stationary seal ring (28).
 - Fit the seal ring in pump casing (9), turn anti-clockwise and tighten (use the tool supplied).

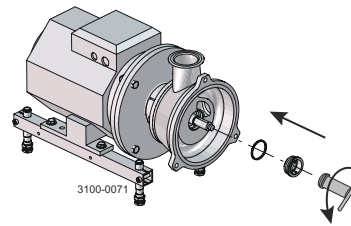

- 13**
- Place key (12) in the groove of stub shaft (3).
 - Fit impeller (11) and impeller nut (13) on the shaft.
 - Tighten the nut clockwise.

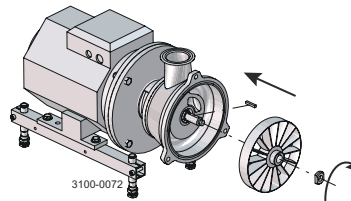

- 14**
- Fit O-ring (8) in pump casing (9).
 - Fit casing cover (10).
 - Fit washers (15a) and cap nuts (14).

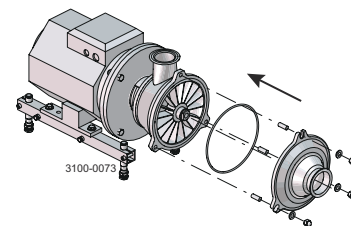

- 15**
- Fit shroud (31).
 - Fit distance sleeve (42), washers (33) and screws (34).

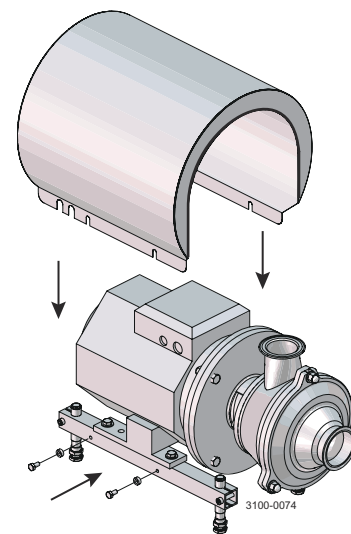

- 16** Fit covers (2a)

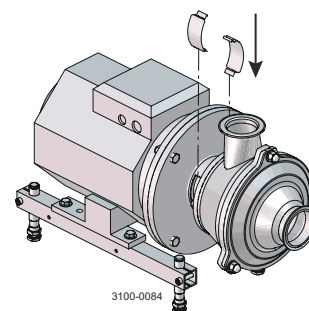

7 Technical Data

NOTE

Technical data must be observed during installation, operation and maintenance.
All personnel should be informed about the technical data.

7.1 Technical Data

MR is a liquid-ring pump specially designed for pumping liquids containing air or gas. The pump is for use in food, chemical, pharmaceutical and similar industries. The pump is mainly used for the CIP-return application.

Materials

Product wetted steel parts:	AISI 316L
Other steel parts:	Stainless steel
Finish:	Standard blasted
Product wetted elastomers:	EPDM (standard) or Nitrile (NBR) and fluorinated rubber (FPM)
Other elastomers:	EPDM
Stationary seal ring:	Carbon
Rotating seal ring:	Acid resistant steel, duplex grade

Motor

Standard foot-flanged motor acc. to IEC metric standard 4 pol = 1500/1800 rpm. at 50/60 Hz. IP55 (with drain holes with labyrinth plug), insulation class F.

Motor sizes	50 Hz	60 Hz
MR-185S:	5.5, 7.5 kW	4.5, 7.5 kW
MR-200S:	5.5, 7.5, 11 kW	7.5, 11 kW

NOTE

50Hz, 230VD/400-415VY; 60Hz, 440-460VY. For other voltages, please refer to Anytime Configurator.

IEC motors (kW)

Motor sizes, 50 Hz:	5.5 Frame size 132 (MR-185S)
	7.5 Frame size 132 (MR-200S)
	11 Frame size 132 (MR-200S)
Motor sizes, 60 Hz:	6.3 Frame size 132 (MR-185S)
	8.6 Frame size 132 (MR-200S)
	12.5 Frame size 132 (MR-200S)

NEMA motors (Hp)

Motor sizes, 60 Hz:	8.44 (MR-185S)
Motor sizes, 60 Hz:	11.5 (MR-200S), 16.75 (MR-200S)

7.2 Operating Data

Pressure

Max. inlet pressure: 400 kPa / 4 bar / 58 psi

Temperature

Temperature range: -10 °C to +140 °C / 14 °F to +284 °F (EPDM)

Motor speed

Max. speed 1800 rpm

7.3 Relubrication Intervals

For recommended general maintenance follow the recommendations in the motor instruction manual.

7.4 Torque Specifications

NOTE

The table below specifies the tightening torques for the screws, bolts and nuts in this pump.

Always use the torques specified below if no other values are shown. This may affect personal safety.

Size	Tightening torque	
	Nm	lbf-ft
M8	20	15
M10	40	30
M12	67	49
M14	110	81

7.5 Weight (kg)

NOTE

Weight can vary depending of configuration. Weight is only to be seen as a reference value during handling, transporting and packaging.

Pump Type: MR

Size	Motor		
	132		160
	5.5 kW	7.5 kW	11 kW
185S	104		
200S		119	160

7.6 Noise Emission

Pump Type	Sound pressure level (dBA)	Pump Type	Sound pressure level (dBA)
LKH-5	60	SolidC-1	68
LKH-10	69	SolidC-2	72
LKH-15	72	SolidC-3	73
LKH-20	70	SolidC-4	72
LKH-25	74	MR-166	76
LKH-35	71	MR-185	82
LKH-40	75	MR-200	81
LKH-45	70	MR-300	82
LKH-50	75	GM	54
LKH-60	77	FM-OS	61
LKH-70	88		
LKH-75	79		
LKH-85	86		
LKH-90	75		
LKH Prime 10	69		
LKH Prime 20	74		
LKH Prime 40	77		
LKH-112	70		
LKH-113	69		
LKH-114	68		
LKH-122	75		
LKH-123	77		
LKH-124	80		

The above LKH noise levels are the same for LKH_{HPF}, LKH_I, LKH UltraPure, LKH Evap and LKH_{Hex}.

The above LKH Prime is the same for LKH Prime UltraPure, LKH_{Hex} Prime and LKH_{Hex} Prime UltraPure.

The above SolidC noise levels are the same for SolidC UltraPure.

The noise measurements have been carried out with the original motor and shroud, approximately at the Best Efficiency Point (BEP) with water at ambient temperature and at 50Hz.

Often the noise level generated by the flow through the process system (eg. valves, pipes, tanks etc.) is much higher than that generated by the pump itself. Therefore it is important to consider the noise level from the whole system and take the necessary precautions with regard to personal safety, if required.

This page is intentionally left blank.

8 Spare Parts

For every delivered Alfa Laval Product, a spare part list is available.

This spare part list contains a range of the most common wear parts for the machinery. If any component not mentioned is required, please contact your local Alfa Laval representative for availability.

You can find our spare part catalogue at <https://hygienicfluidhandling-catalogue.alfalaval.com>.

Always use Alfa Laval genuine spare parts. The warranty of Alfa Laval products is dependent on use of Alfa Laval genuine spare parts.

8.1 Ordering Spare Parts

When ordering spare parts, please always state:

1. Serial number (if available)
2. Item number/spare part number (if available)
3. Capacity or other relevant identification

8.2 Alfa Laval Service

Alfa Laval is represented in all larger countries of the world.

Do not hesitate to contact your local Alfa Laval representative, with any questions or requirement of spare parts for Alfa Laval equipment.

8.3 Warranty - Definition



The rules of Intended use are absolute. Use of the supplied Alfa Laval product is allowed only when in compliance with the technical data supplied with the Intended use.

Differing utilisation, other than agreed with Alfa Laval Kolding A/S, exclude any liability and warranty.

No modification or alteration of the supplied Alfa Laval product is allowed, unless explicit permission is granted by Alfa Laval Kolding A/S.



Liability and warranty are excluded:

- If advice and instruction of operating instructions are ignored
- For incorrect operation or for insufficient maintenance of the supplied Alfa Laval product
- For any kind of change of function of the supplied Alfa Laval product without prior written agreement by Alfa Laval Kolding A/S
- If supplied Alfa Laval product is modified by non-authorized persons
- If using the supplied Alfa Laval product without attention of appropriate safety regulations, (see [Safety](#) on page 7)
- If protection equipment is not used and vessel process / ancillary equipment is not brought to a standstill
- If the supplied Alfa Laval product and ancillary parts are not properly maintained (to be executed in intervals and including fitting of prescribed replacement parts)

When exchanging parts, only original replacement parts, released from the manufacturer, must be used.

9 Parts Lists and Exploded Views

9.1 Drawings MR-185 / MR-200

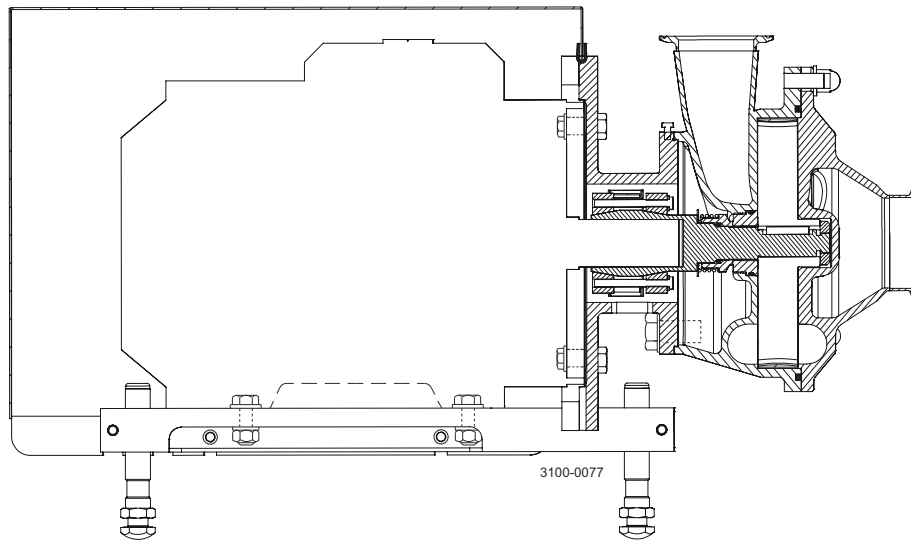

Shaft seal

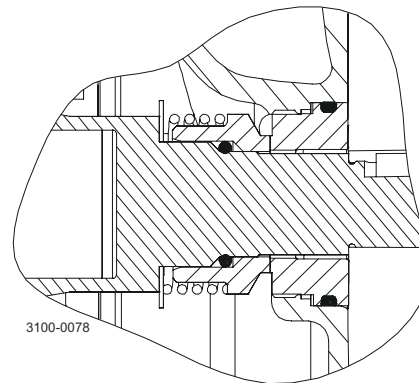

9.2 MR - Wet end

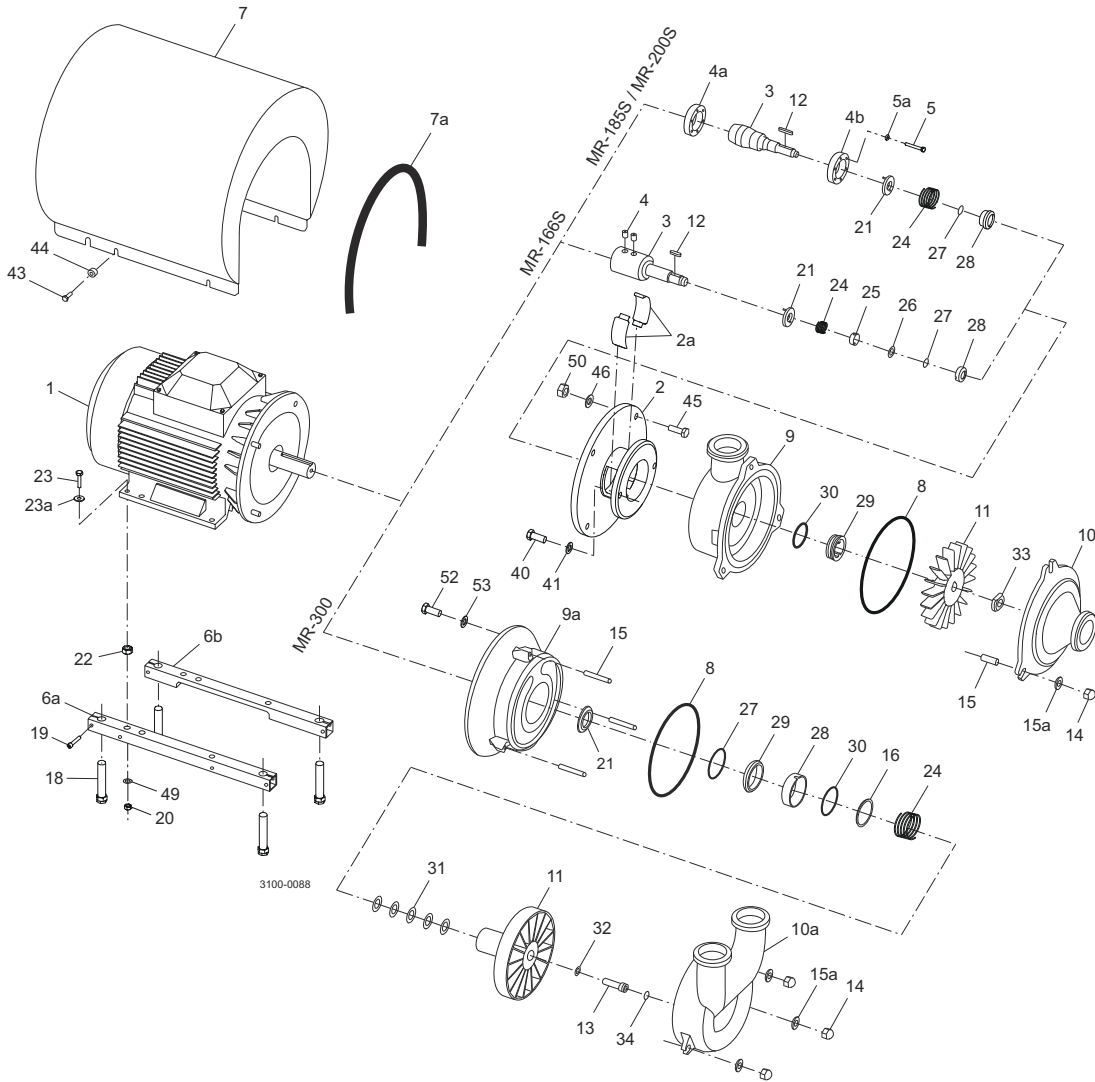

Pos.	Qty.	Denomination
8	1	O-ring, EPDM (Standard)
9	1	Pump casing
10	1	Casing cover
10a	1	Casing cover
11	1	Impeller
13		Impeller screw
14	3	Cap nut

Pos.	Qty.	Denomination
15	3	Stud bolt
15a	3	Washer
21	1	Thrower
31	1-2	Shims, 0.1 mm
32	1	Washer for impeller screw
33	1	Impeller nut
34	1	O-ring, EPDM (Standard)

9.3 MR - Motor dependent parts

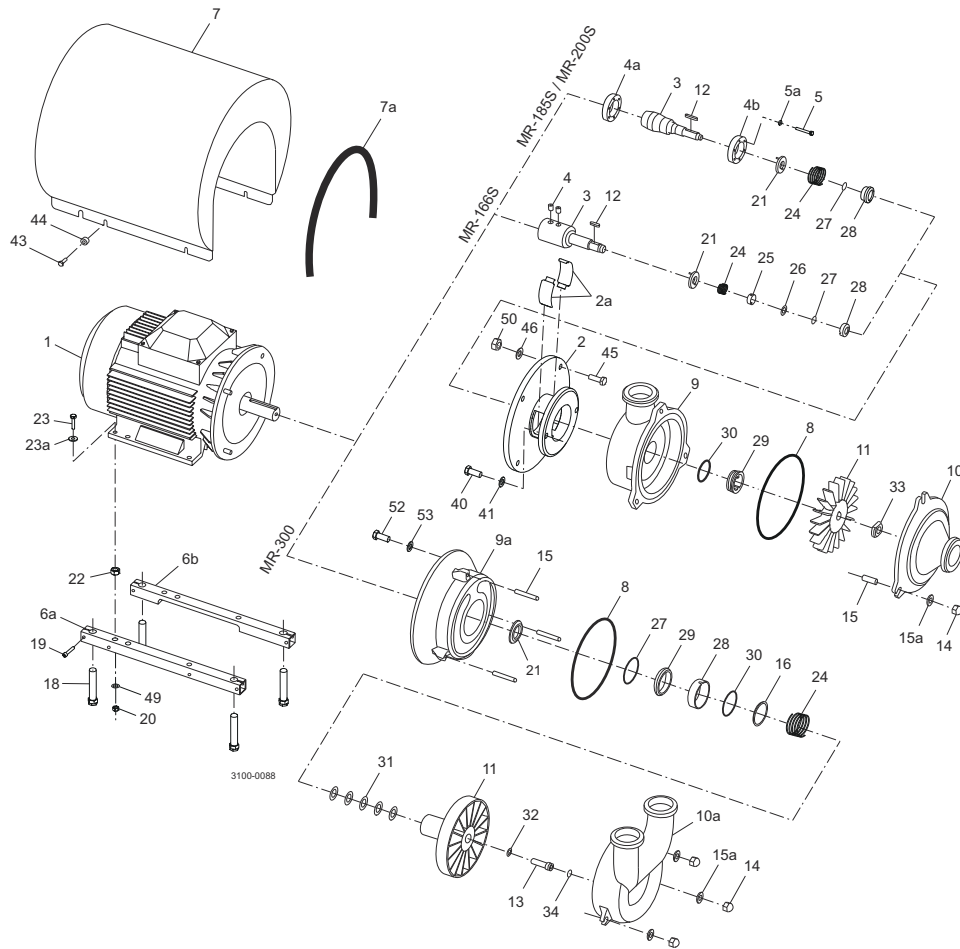

Pos.	Qty.	Denomination
1	1	Motor ABB
2	1	Bracket
2a	2	Bracket cover
3	1	Shaft
4	2	Screw
4a	1	Compression ring
4b	1	Compression ring
5	6	Screw
5a	6	Washer
6a	1	Support bar, right
6b	1	Support bar, left
7	1	Shroud complete
7a	1	Edge list
12	1	Key
18	4	Legs

Pos.	Qty.	Denomination
19	4	Screw
20	4	Nut
22	4	Nut
23	4	Screw
23a	4	Washer
40	2	Screw
41	2	Spring washer
43	4	Screw
44	4	Distance sleeve
45	4	Screw
46	4	Washer
49	4	Spring washer
50	4	Nut
52	4	Screw
53	4	Spring washer

9.4 MR - Shaft seal

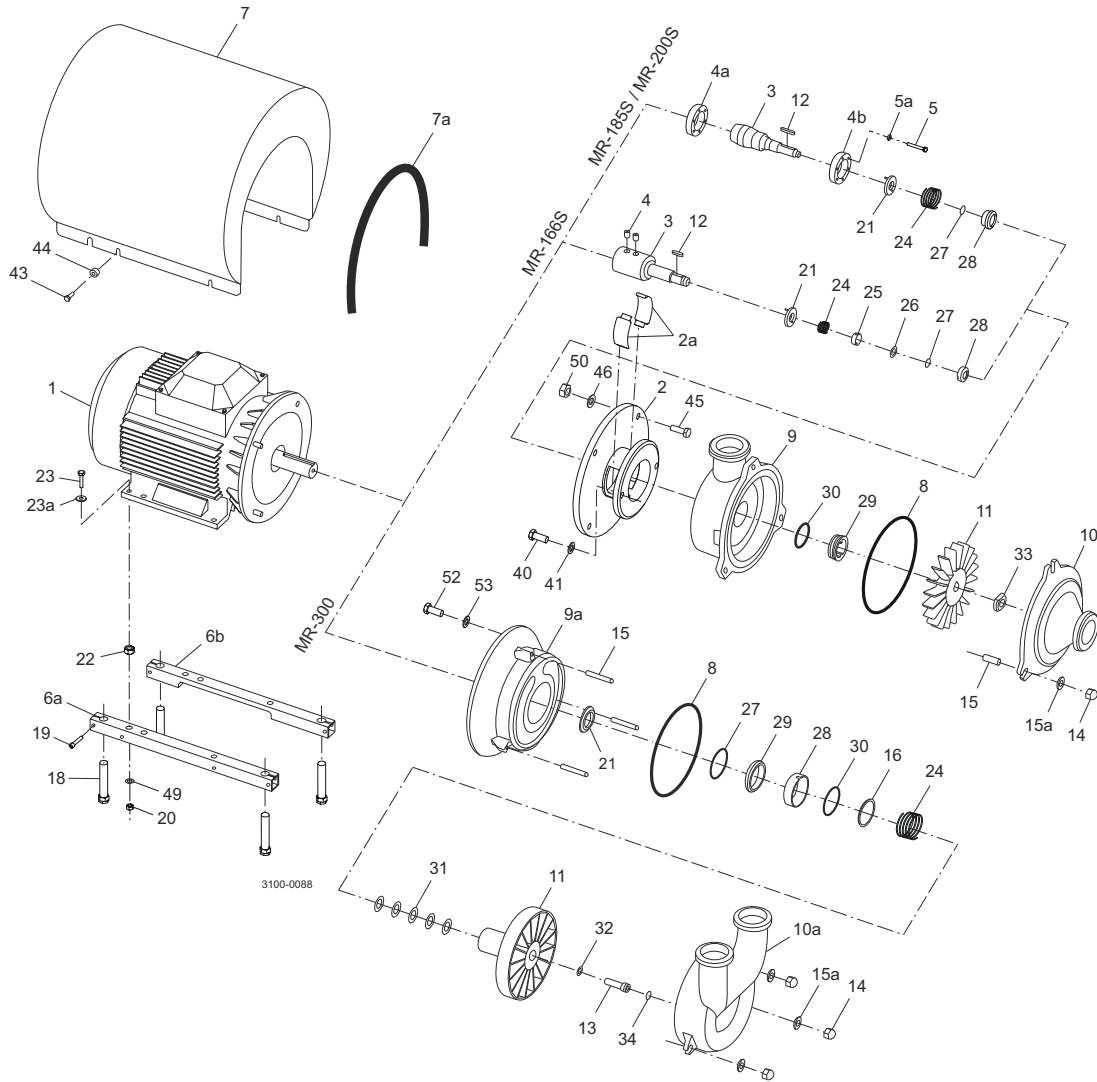

Pos.	Qty.	Denomination
24	1	Spring
25	1	Space ring
26	1	Washer
27	1	O-ring

Pos.	Qty.	Denomination
28	1	Rotating seal ring
29	1	Stationary seal ring
30	1	O-ring