

Note that all unique customer requirements (i.e tolerance) need to be verified thru Alfa Laval.

120

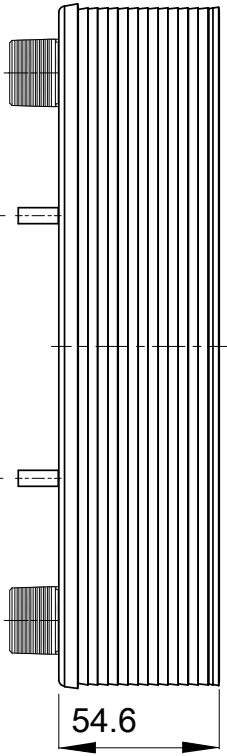

54.6

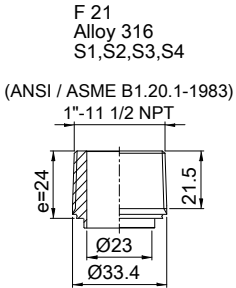

F 21
Alloy 316
S1,S2,S3,S4

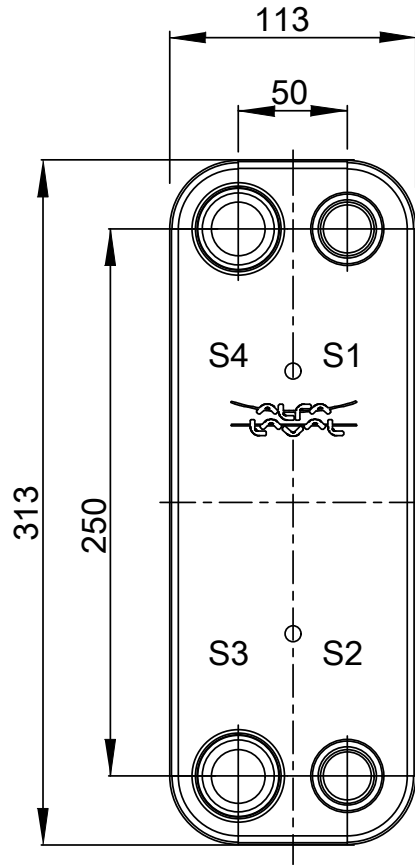

313

250

113

50

S4 S1

S3 S2

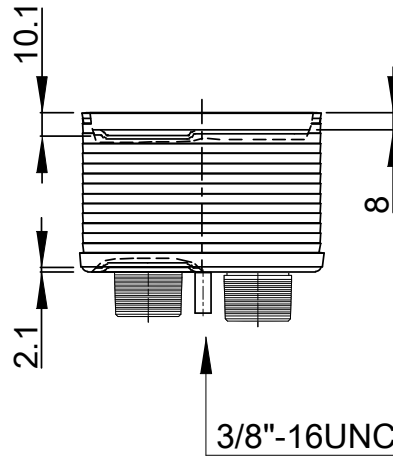

8

2.1

10.1

3/8"-16UNC x 25 (2x)

HEATING SURFACE
NETWEIGHT 3.5 kg
OPERATING WEIGHT kg
PLATE MATERIAL ALLOY 316
PLATE GROUPING 1*8L/1*9L

T1 T2 T3 T4 locations on back side correspond to S1 S2 S3 S4 on front side

ALL DIMENSIONS IN MILLIMETERS

SIDE	MEDIA	INLET	TEMP.	OUTLET	TEMP.	FLOW RATE	PRESSURE DROP	LIQUID VOL.
1		S1		S2				0.49 dm ³
2		S3		S4				0.43 dm ³



PRESSURE VESSEL APPROVAL
CB30-18L (3287099366)

UL/CRN

www.alfalaval.com

CUSTOMER NAME / REF. NO.

TOTAL LENGTH 80.6 mm
TOTAL WIDTH 113.0 mm
TOTAL HEIGHT 313.0 mm

COMPANY / REF.

1/15/2024
REV 0