

Alfa Laval 761 Seat Valve

The Industry Standard

Concept

This air-operated seat valve features the positive action of either a short-stroke or long-stroke actuator. The 761 valve is ideal for high volume, hygienic liquid processing applications. Its heavy-duty construction and precision-molded bonnet gaskets ensure positive alignment under severe operating conditions. The 761 valve has a hygienic and flexible design allowing it to be used in a wide range of applications, e.g. as a stop valve with two or three ports or as divert valve with three to five ports.

Working principle

The valve is remote-controlled by means of compressed air. It has few and simple moveable parts which results in a very reliable valve.

Standard Design

The 761 Series valves are designed to deliver years of reliable performance. Rugged and long-lasting plastic stem bushings eliminate metal-to-metal galling. The stems are threaded to the actuator shaft, eliminating the coupling between the stem and the actuator, thereby ensuring proper alignment. The valve stem design requires only a single o-ring seal. And bushings at each end of the actuator cylinder support stem also ensure perfect alignment. The 761 series features a heavy-duty bonnet and body ferrule design that will stand up to years of pounding from hydraulic shock. Standard 32Ra finish on the ID.

Valve body combinations

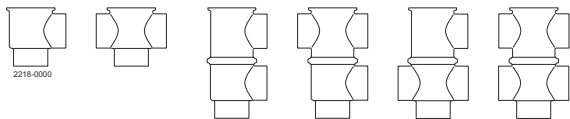

10

30

21

41

43



TECHNICAL DATA

Pressure

Max. product pressure:	Depends on valve specifications and size (contact Alfa Laval)
Air pressure:	60-80 PSI

Temperature

Temperature range:	200 °F to 284 °F (EPDM)
--------------------	-------------------------

PHYSICAL DATA

Materials

Product wetted steel parts:	Stainless steel AISI 316L
Finish:	32 Ra Standard
Other steel parts:	Stainless steel AISI 304
Plug stem:	Buna bonded or "TR"/"TR2" PTFE replaceable
Product wetted seals:	Buna
Process connections:	Tri-Clamp®

Other valves in the same basic design:

- Remote controlled valve, type SRC
- Aseptic Remote controlled valve, type ARC
- Long Stroke valve, type SRC-LS
- Manual valve, type SMO
- Manual valve, type SRC-BC
- Manual valve, type SMO-R, SMO-RA

Pressure drop/capacity diagrams

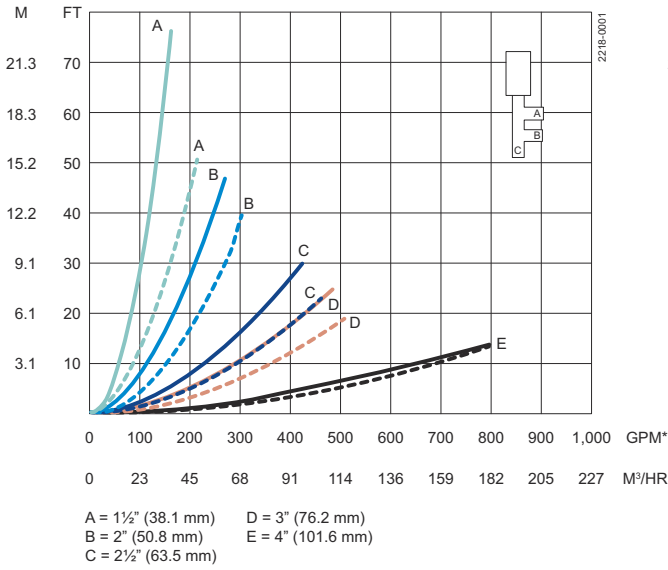

Figure 1. 761 Short-Stroke Divert Valve

- Body Styles 21, 23, 41 & 43
- Flow Pattern: B to A (Solid Curve), B to C (Broken Curve)
- In some cases, with low-viscosity liquids, the pressure drop in the long-stroke valve may actually be greater than the short-stroke valves

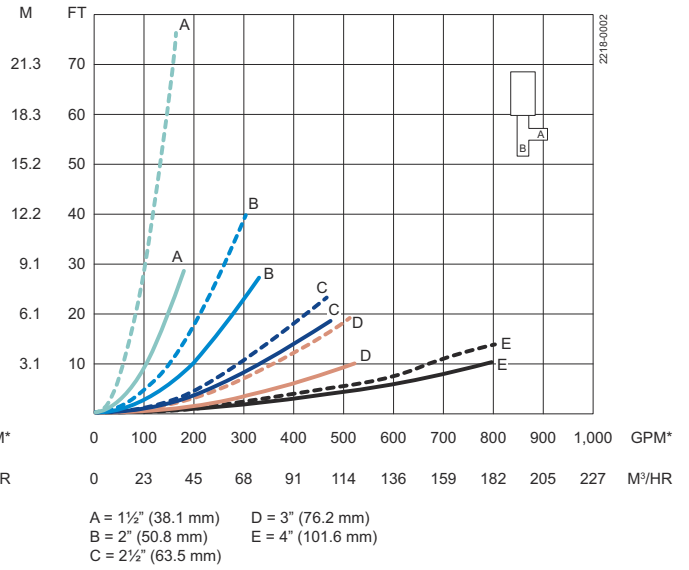

Figure 2. 761 Short-Stroke Shut-Off Valve

- Body Styles 10 & 30
- Flow Pattern: B to A (Solid Curve), A to B (Broken Curve) - Crossbodies Only
- In some cases, with low-viscosity liquids, the pressure drop in the long-stroke valve may actually be greater than the short-stroke valves

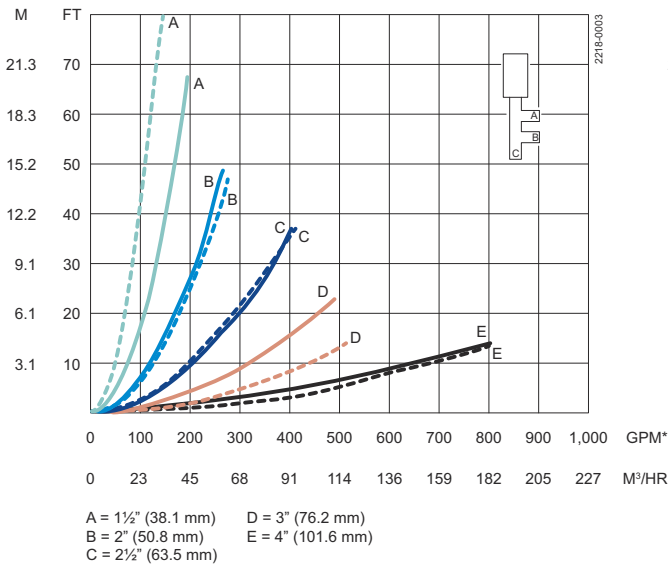

Figure 3. 761 Long-Stroke Divert Valve

- Body Styles 10 & 30
- Flow Pattern: B to A (Solid Curve), B to C (Broken Curve)
- In some cases, with low viscosity liquids, the pressure drop in the long-stroke valve may actually be greater than the short-stroke valves

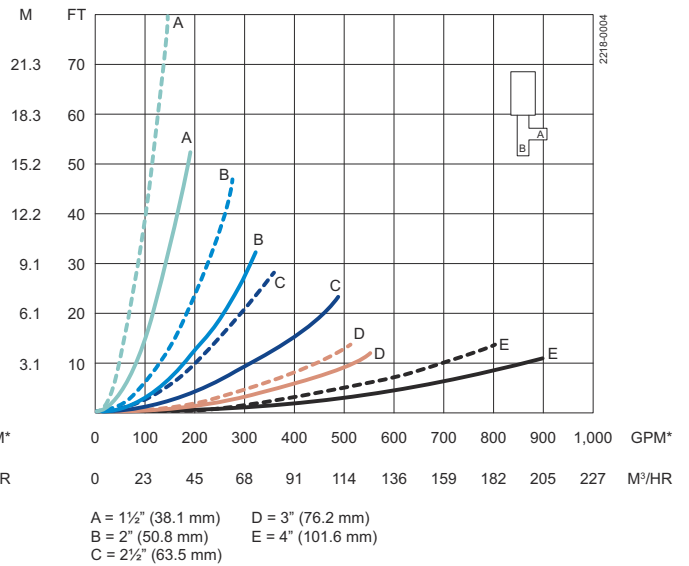

Figure 4. 761 Long-Stroke Shut-Off Valves

- Body Styles 10 & 30
- Flow Pattern: B to A (Solid Curve), A to B (Broken Curve) - Crossbodies Only In some cases, with low-viscosity liquids, the pressure drop in the long-stroke valve may actually be greater than the short-stroke valves

Dimensions (inch)

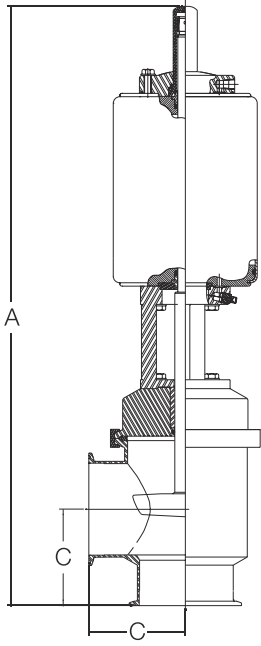

Figure 5. 76-110

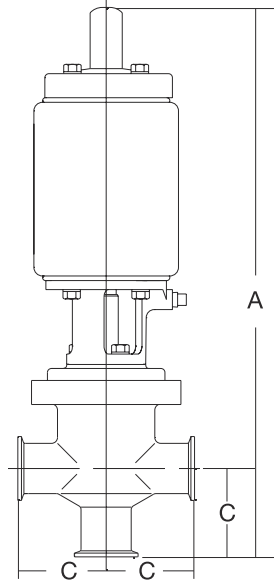

Figure 6. 761-30

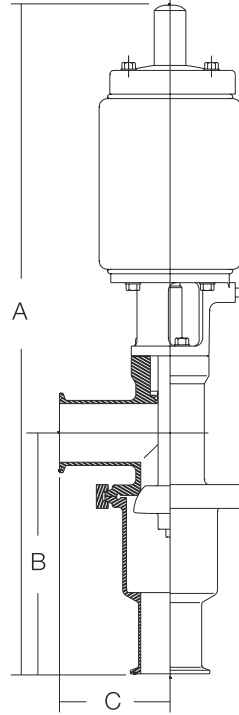

Figure 7. 761-27 Reverse-Acting

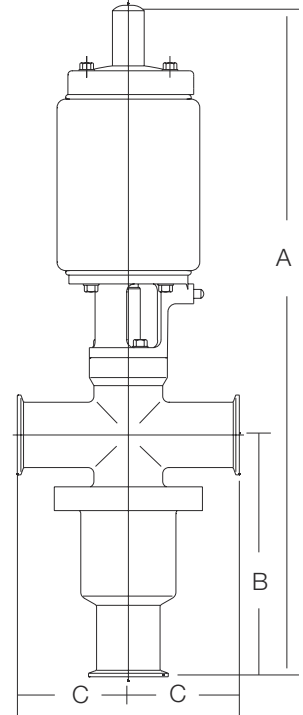

Figure 8. 761-47 Reverse-Acting

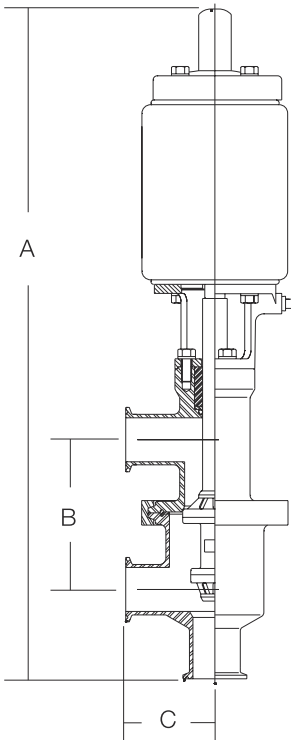

Figure 9. 761-21

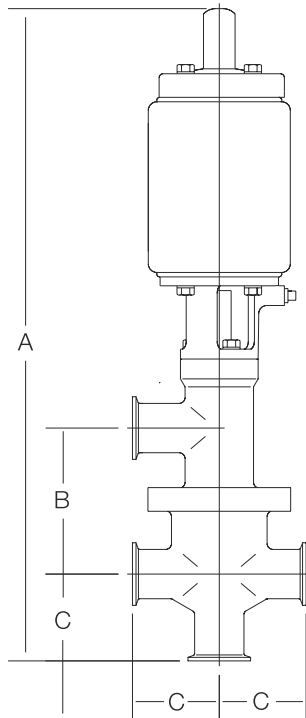

Figure 10. 761-23

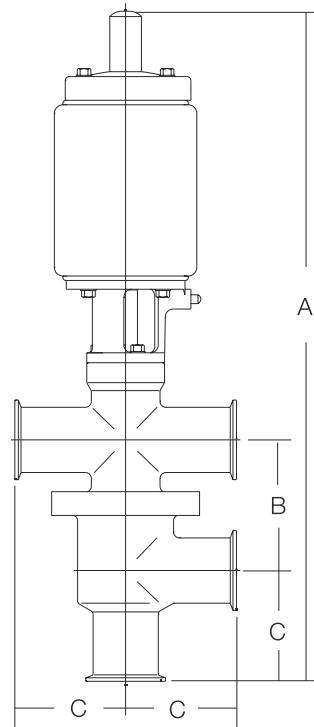

Figure 11. 761-41

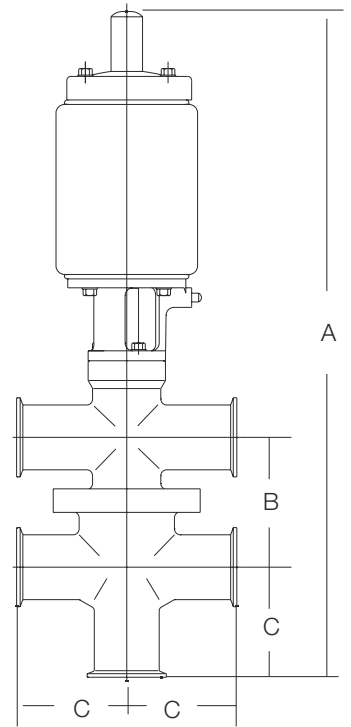

Figure 12. 761-43

761 Shut-Off and Divert Valves

Valve Size (Tube OD)	A						B						C	
	Shut-Off Valves				Divert & Reverse-Acting ¹ Shut-Off Valves				Divert Valves		Reverse Acting Shut-Off Valves			
	Short		Long		Short		Long		inch	mm	inch	mm	inch	mm
	inch	mm	inch	mm	inch	mm	inch	mm						
1-inch	14.88	378.00	NA	NA	NA	NA	NA	NA	NA	NA	NA	NA	2.50	64.00
1½-inch	17.13	435.00	21.09	536.00	20.73	526.00	24.69	627.00	4.63	117.00	7.38	187.00	2.75	70.00
2-inch	17.63	448.00	21.56	548.00	21.19	538.00	25.16	639.00	4.13	105.00	7.63	194.00	3.50	89.00
2½-inch	17.56	446.00	21.53	547.00	21.85	555.00	25.81	656.00	4.50	114.00	8.00	203.00	3.50	89.00
3-inch	18.06	459.00	22.03	560.00	22.85	580.00	26.81	681.00	5.00	127.00	8.75	222.00	3.75	95.00
4-inch	24.97	634.00	31.09	790.00	31.00	787.00	37.09	942.00	6.00	152.00	NA	NA	4.00	102.00

¹ Reverse-acting NA in long stroke



Note!

For valves with control housings, add the following to dimension A:

Short stroke sizes: 1-3" (25.4-76.2 mm), Add: 19/16" (39.7 mm)

Long stroke sizes: 1½ - 4" (38.1-101.6 mm), Add: 3/4" (19.0 mm)

761 Shut-Off and Divert Valves with Variable and Mid-Position "80S" Actuator

Valve Size (Tube OD)	A				B		C	
	Shut-Off Valves		Divert Valves		inch	mm	inch	mm
	Short	mm	Short	mm				
1½-inch	17.75	451.00	23.31	592.00	4.62	117.00	2.75	70.00
2-inch	18.25	464.00	23.56	598.00	4.12	105.00	3.50	89.00
2½-inch	18.19	462.00	23.94	608.00	4.50	114.00	3.50	89.00
3-inch	18.69	475.00	24.69	627.00	5.00	127.00	3.75	95.00

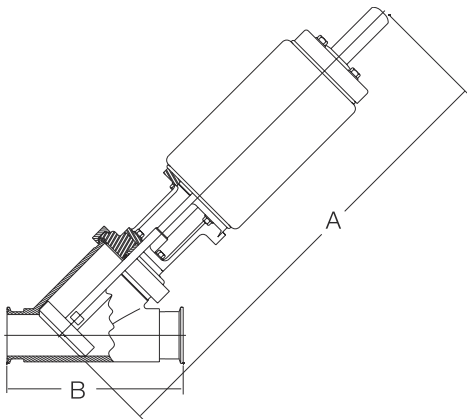

761-90 "Y" Body Shut-Off Valves

Valve Size (Tube OD)	A		B		C ¹	
	inch	mm	inch	mm	inch	mm
1½-inch	20.63	524.00	6.38	162.00	22.31	567.00
2-inch	22.38	568.00	7.88	200.00	24.63	625.00
2½-inch	22.94	583.00	9.25	235.00	25.44	646.00
3-inch	28.94	735.00	10.38	264.00	29.69	754.00
4-inch	32.13	816.00	12.63	321.00	32.88	835.00

¹ Column "C" represents dimension "A" with the addition of a control housing module

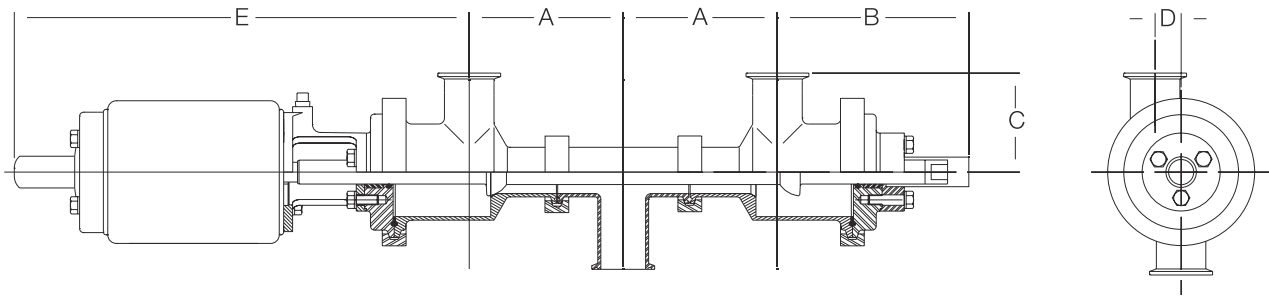

Reverse-Acting Divert Valves 761-21 MRALL (Left Hand Tangential) 761-21 MRARR (Right Hand Tangential)

Valve Size	A		B		C		D		E	
	inch	mm	inch	mm	inch	mm	inch	mm	inch	mm
2-inch	4.72	120.00			3.50	89.00	0.51	13.00	13.69	348.00
2½-inch	5.25	133.00	6.03	153.00	3.50	89.00	0.81	21.00	13.94	354.00
2½ HP	5.25	133.00	6.03	153.00	3.50	89.00	0.81	21.00	16.28	414.00
3 HP	5.75	146.00	6.28	159.00	3.75	95.00	0.81	21.00	18.88	479.00
4 HP	7.08	180.00	9.30	236.00	4.02	102.00	0.48	12.00	22.00	559.00



Note! For valves with control housings, add the following to dimension E: 1½-3" (38-76 mm), add 19/16"(40 mm)

Actuator function

- Pneumatic downward movement, spring return (NO)
- Pneumatic upward movement, spring return (NC)
- Pneumatic upward and downward movement (A/A)
- Actuator for intermediate position of the valve plug as option

Type 10 (Normally-Open) Shut-off valve holding pressures – 70 PSI air pressure supplied to actuator

Size	Short Stroke Actuator (Standard) ¹			Long Stroke Actuator (Standard) ¹			Type 15
	Elastomer	"TR"	Stroke Length	Elastomer	"TR"	Stroke Length	20 PSI
1-inch	105 PSI	110 PSI	0.75"	NA	NA	NA	50
1½-inch	120 PSI	110 PSI	1"	120 PSI	110 PSI	2"	26
2-inch	80 PSI	70 PSI	1"	125 PSI	120 PSI	2"	18
2½-inch	35 PSI	20 PSI	1"	60 PSI	50 PSI	2"	10
3-inch	20 PSI	15 PSI	1"	45 PSI	40 PSI	2"	7
4-inch	35 PSI	20 PSI	2"	40 PSI	20 PSI	4"	NA

¹ 4½" diameter actuator is standard on the 1"- 3" valves. A 6" diameter actuator is supplied with the 4" valve. A 4½" diameter actuator for the 4" valve is available upon request

Type 10 (Normally-Open) Shut-off valve holding pressures – 90 PSI air pressure supplied to actuator

Size	Short Stroke Actuator (Standard) ¹			Long Stroke Actuator (Standard) ¹		
	Elastomer	"TR"	Stroke Length	Elastomer	"TR"	Stroke Length
1-inch	105 PSI	105 PSI	0.75"	NA	NA	NA
1½-inch	150 PSI	150 PSI	1"	150 PSI	150 PSI	2"
2-inch	150 PSI	150 PSI	1"	150 PSI	150 PSI	2"
2½-inch	90 PSI	80 PSI	1"	120 PSI	110 PSI	2"
3-inch	70 PSI	60 PSI	1"	80 PSI	70 PSI	2"
4-inch	80 PSI	75 PSI	2"	100 PSI	80 PSI	4"

¹ 4½" diameter actuator is standard on the 1"-3" valves. A 6" diameter actuator is supplied with the 4" valve. A 4½" diameter actuator for the 4" valve is available upon request

Type 20 (Normally-Closed) Shut-off valve holding pressures (Standard)**

Size	Short Stroke Actuator (Standard) ¹			Long Stroke Actuator (Standard) ¹			Type 25 Reverse Acting
	Elastomer	"TR"	Stroke Length	Elastomer	"TR"	Stroke Length	psig
1-inch	105 PSI	110 psi	0.75"	NA	NA	**	NA
1½-inch	140 PSI	140 PSI	1"	140 PSI	140 PSI	2"	40
2-inch	90 PSI	90 PSI	1"	90 PSI	90 PSI	2"	25
2½-inch	55 PSI	55 PSI	1"	55 PSI	55 PSI	2"	15
3-inch	40 PSI	40 PSI	1"	32 PSI	25 PSI	2"	10
4-inch	65 PSI	65 PSI	2"	45 PSI	40 PSI	4"	NA

¹ 4½" diameter actuator is standard on the 1"-3" valves. A 6" diameter actuator is supplied with the 4" valve. The 6" diameter actuator is available, as a heavy duty option, for the 3" valve.

** On a standard actuator it takes 30 PSI to offset the spring force when fully extended and 60 PSI to fully compress the spring.

Type 20 (Normally-Closed) Optional "HP" high pressure actuator. (6" diameter actuator)

Size	Short Stroke Actuator (Standard*)			Long Stroke Actuator (Standard*)		
	Elastomer	"TR"	Stroke Length	Elastomer	"TR"	Stroke Length
2½-inch	110 PSI	110 PSI	1"	115 PSI	110 PSI	2"
3-inch	95 PSI	90 PSI	1"	100 PSI	95 PSI	2"

Actuator Air Supply Specifications

See chart below for minimum air pressure requirements. Maximum air pressure is 100 PSI (normal). Air volume required is identified by the length of the stroke.

Valve Size	Stroke (inch)	Volume (cu. inch)
1-inch	0.75	11.10
1½ - 3-inch short stroke	1	14.80
1½ - 3-inch long stroke	2	29.50
4-inch short stroke HP	2	50.00
4-inch long stroke HP	4	95.00
Type 15 diaphragm	1	9.00



Note! Lubricated air is not required. Filtered air and a pressure regulator valve are required.

Additional Holding Pressure

Additional air supply must be relieved when product pressure is not present. Failure to do so will result in pressure damage to the seat. When using additional air loading it should exceed the minimum required by no more that 3 to 5 PSI.

Example: A customer has an application for a 3" valve that is required to hold 70 PSI product pressure with an elastomer (Buna). The valve without an air assist will hold 40 PSI. An additional holding force to overcome 30 PSI (70 PSI-40 PSI) is needed. Since the ratio is 5:10 (air-to-product pressure ratio) a 15 PSI air assist is needed.



Note! Since it takes 60 PSI to fully stroke the valve without air assist, it will take 75 PSI to open the example. (60 PSI + 15 PSI)

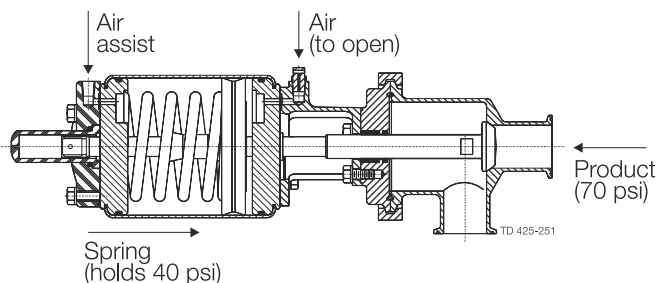

Valve Size	Air to Product Pressure Ratio	Max Recommended Air Assist	Max. Product Holding Pressure
1-inch	01:10	10	200
1½-inch	01:10	5	200
2-inch	02:10	10	150

Valve Size	Air to Product Pressure Ratio	Max Recommended Air Assist	Max. Product Holding Pressure
2½-inch	03:10	20	100
3-inch	05:10	35	100
4-inch HP	04:10	25	100

Options

Equipment

- Process connections, weld, bevel seat
- Control and indication (Control Top or ThinkTop®)
- High pressure actuator for 2½" and 3" size
- High pressure actuator for 2½" and 3" size
- Three Position Actuator (80)
- 20 Ra or 15 Ra ID surface finish
- Long stroke actuator

Material grades

- Molded elastomers of EPDM, SFY, or PTFE
- O-rings and seals of EPDM or SFY (Flouroelastomer)

Ordering

Please state the following when ordering:

- Size
- Connections
- Valve body combination
- Actuator function, NC, NO or A/A
- Options

This document and its contents are subject to copyrights and other intellectual property rights owned by Alfa Laval Corporate AB. No part of this document may be copied, re-produced or transmitted in any form or by any means, or for any purpose, without Alfa Laval Corporate AB's prior express written permission. Information and services provided in this document are made as a benefit and service to the user, and no representations or warranties are made about the accuracy or suitability of this information and these services for any purpose. All rights are reserved.

200007789-1-EN-US

© Alfa Laval Corporate AB

How to contact Alfa Laval

Up-to-date Alfa Laval contact details for all countries are always available on our website at www.alfalaval.com