

# Alfa Laval Emmie

## Mobile hydraulic oil cleaning system

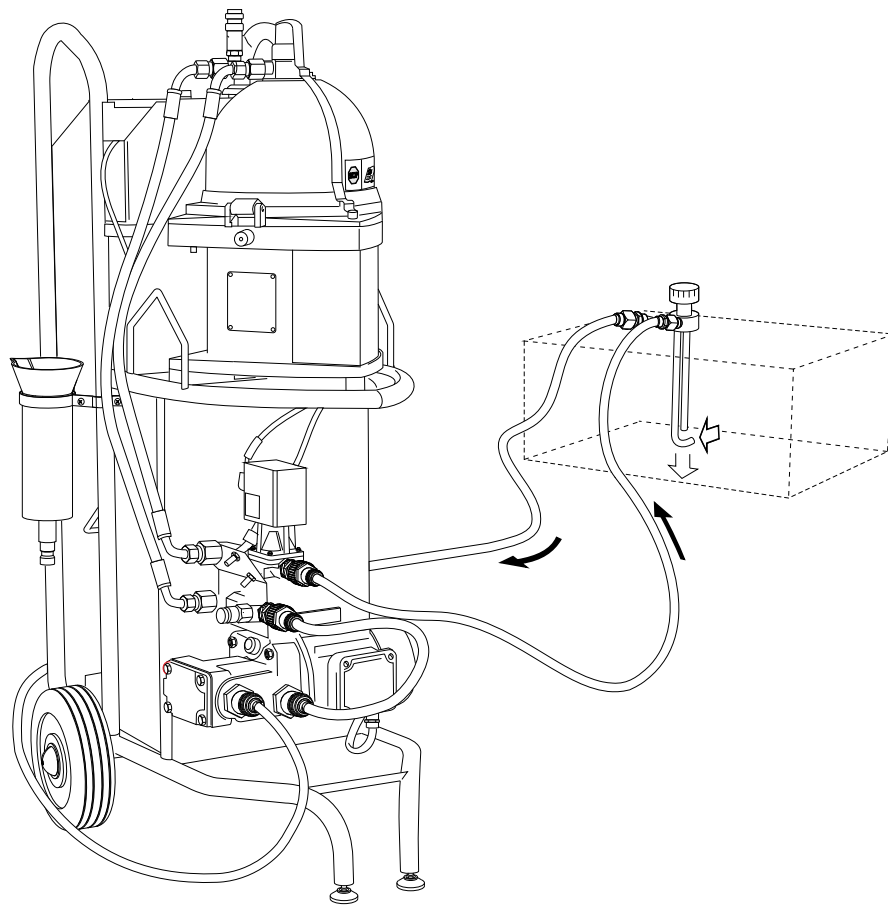

# Instruction Manual



Book No.: 9017368-02 V7  
Product no.: 9016161-80, -81, -82, -83  
9016162-80, -81, -82, -83

**Published By:**

Alfa Laval Tumba AB  
SE-147 80 Tumba, Sweden

Telephone: +46 8 530 650 00

Telefax: +46 8 530 310 40

© Alfa Laval Tumba AB 05-2016

**Original instruction**

This publication or any part there of may not be reproduced or transmitted by any process or means without prior written permission of Alfa Laval Tumba AB.

---

# ***Contents***

---

<b>1</b>	<b>Safety instructions</b>	<b>7</b>
<b>2</b>	<b>Application</b>	<b>9</b>
<b>3</b>	<b>Machine plates</b>	<b>11</b>
<b>4</b>	<b>Description of main parts</b>	<b>13</b>
4.1	System overview	13
4.2	Hoses	16
4.3	Separator	17
4.4	Pump	17
4.5	Control unit	17
4.6	Collecting tank	18
<b>5</b>	<b>Working principle of the separator</b>	<b>19</b>
5.1	Introduction	19
5.2	Clarifier operation	21
5.3	Purifier operation	21
5.4	Changing operation mode	22
<b>6</b>	<b>Control Cabinet</b>	<b>25</b>
6.1	Operator panel	25
6.2	Connection for correct voltage	31
6.3	Alarm light pattern	32
6.4	Alarm table	33
<b>7</b>	<b>Operating instructions</b>	<b>35</b>
7.1	Separation time	35
7.2	Separation mode	35
7.3	Before start	37
7.4	Start	40
7.5	Operation	44

---

7.6	Standby	44
7.7	Stop	45
7.8	How to drain hoses	46
<b>8</b>	<b>Trouble shooting</b>	<b>47</b>
8.1	Cleaning system/separator does not start or stops shortly after start	47
8.2	Pump does not start	47
8.3	Pump stops	47
8.4	Separator stops	48
8.5	Noise	48
8.6	Separator vibrates	49
8.7	Insufficient separation result	49
8.8	No flow from pump	49
8.9	Flow too low	50
8.10	No flow either through clean oil outlet or through drain to collecting tank	50
8.11	Some liquid escaping through drain outlet to collecting tank	51
8.12	Oil flow through drain outlet to collecting tank only	51
8.13	Oil leakage through drain outlet to collecting tank when separator is not running	51
8.14	Collecting tank overflowing but pump does not stop	51
8.15	Separation temperature too low	52
<b>9</b>	<b>Maintenance</b>	<b>53</b>
9.1	Cleaning	53
9.1.1	Separator	53
9.1.2	Strainer	54
9.2	Once per year	54
9.2.1	Separator	54
9.3	Every second year	55
9.3.1	Separator	55
9.4	Dismantling - assembly instructions for separator	55
9.4.1	Introduction	55
9.4.2	Cleaning of bowl	56
9.4.3	Replacement of O-rings in purifier bowl	60

---

9.4.4	Replacement of O-rings in clarifier bowl	62
9.4.5	Replacement of motor bearings	64
<b>10</b>	<b>Technical data</b>	<b>67</b>
10.1	Technical data, system	67
10.2	Declaration	68
<b>11</b>	<b>Installation</b>	<b>69</b>
11.1	Installation alternatives	69
11.1.1	Replacement of filler cap	69
11.1.2	Connection to drain hole in tank	70
11.1.3	Using separate suction and return pipes	70
<b>12</b>	<b>Lifting instruction</b>	<b>71</b>
12.1	Cleaning unit	71
<b>13</b>	<b>Diagrams</b>	<b>73</b>
13.1	Electrical system	73

---

---

# 1 *Safety instructions*

---



**Study this instruction manual and observe the warnings before installation, operation, service and maintenance. Not following the instructions can result in serious accidents.**

The centrifugal separator, which is the major part of the cleaning unit, includes parts that rotate at high speed.

Incorrect operation and maintenance of the cleaning unit can result in serious damage and/or injury.

The following basic safety instructions therefore apply:

- **Use the cleaning unit only for the purpose and parameter range specified by Alfa Laval.**
- **Only use the cleaning unit in non-explosion environment.**
- **Strictly follow the instructions for installation, operation and maintenance.**
- **Ensure that personnel are competent and have sufficient knowledge of maintenance and operation.**
- **Use only Alfa Laval genuine spare parts and the special tools supplied.**



## **Electrocution risk**

**Switch off the power supply and remove the electric cable from the socket before opening the starter/control unit.**



### Disintegration hazard

The separator is supplied with a safety yoke and a magnetic safety switch. Modifications to the machine which put the safety devices out of operation can lead to serious injury or damage.

If excessive vibrations occur, **stop** the separator.



### Entrapment hazard

Make sure that rotating parts inside the separator have come to a **complete standstill** before moving the cleaning unit or starting any dismantling work.

To avoid accidental start, switch off the power supply and remove the electric cable from the socket before starting **any** dismantling work.

### Warning labels

A warning label is placed on the separator hood.  
The interpretation of the label is: **STOP!** Read the instruction manual before installation, operation and maintenance. Consider inspection intervals. Another warning label is placed on the door for the heater control unit. The interpretation of the label is: Switch off the power before opening the cover.



*Warning label located on separator hood*



---

## 2 Application

---

The *Alfa Laval Emmie* oil cleaning module is here included in the Alfa Laval Emmie oil cleaning system. The module can be bought separately and included in a similar system to the one described in this book.

The *Alfa Laval Emmie* hydraulic oil cleaning system is restricted to the removal of solids and water from mineral hydraulic, gear and sterntube lube oils with a maximum temperature of +65 °C and with a maximum viscosity (VG) of 150 cSt at 40 °C



### Disintegration hazard

The cleaning system must not be operated in an explosion environment.



Never use *Alfa Laval Emmie* on engine lube oils as any small amount of remaining engine lube oil in the system can seriously affect and change the properties of the hydraulic oil if mixed.



Never connect *Alfa Laval Emmie* to a pressurized system with the same or higher pressure than the pressure switch set point (50 kPa). Otherwise the safety function of the switch will be overridden, which means that the pump and heater can operate without flow.



---

## 3 Machine plates

---

The cleaning unit has two different machine plates.

1. One for the separator only
2. One for the complete unit

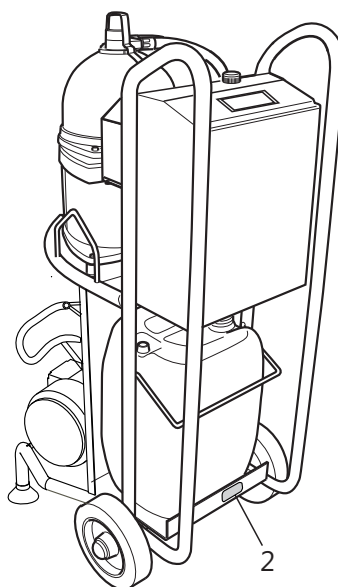
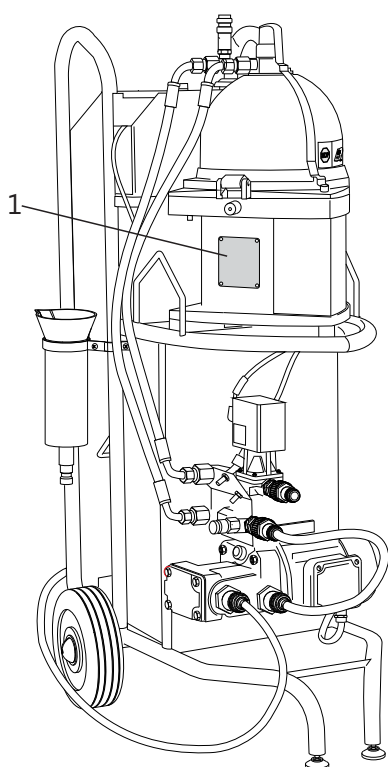

G1113011

### NOTE

When ordering spare parts for the cleaning unit (except the separator) please specify the article and serial numbers stamped on the machine plate (1) for the complete unit.

### NOTE

When ordering spare parts for the separator itself, please specify the type, product and serial numbers stamped on the machine plate (2) for the separator.

### 3 Machine plates

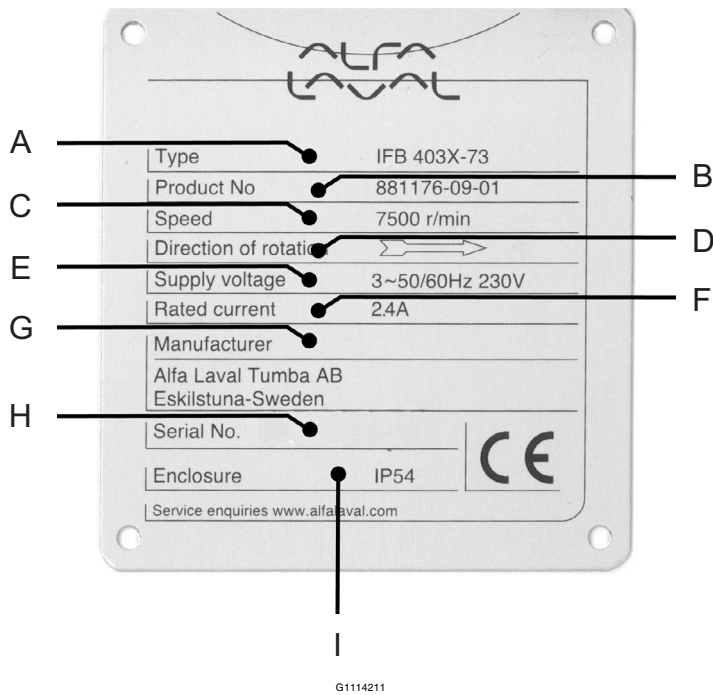

#### Example of machine plate (separator only)

- |                           |                                    |
|---------------------------|------------------------------------|
| A. Type:                  | F. Rated current: (for separation) |
| B. Product No.:           | G. Manufacturer:                   |
| C. Speed:                 | H. Serial No.:                     |
| D. Direction of rotation: | I. Enclosure:                      |
| E. Supply voltage:        |                                    |

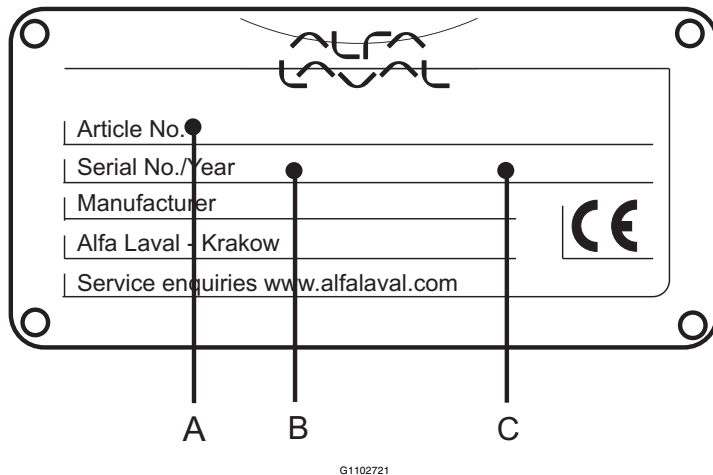

#### Example of machine plate (complete unit)

- A. Article No.
- B. Serial No.
- C. Manufacturing Year

Note that the illustrations are examples of a machine plates. Values shown on the illustrations are not valid for all machines.

---

# 4 *Description of main parts*

---

## 4.1 System overview

The *Alfa Laval Emmie* unit consists of the following parts (numbered in process order):  
Parts marked with \*) are further described on pages [16](#) to [18](#).

Please turn over.

1. **Coupling device fitted in oil tank**
2. **Inlet hose (1/2") from tank to pump \*)**
3. **Feed pump for the oil \*)**
4. **Hose (1/2") from pump to inlet\*)**
5. **Bleeding valve**  
Manually evacuates air at start and at emptying the system.
6. **Check-valve before separator**  
The valve is spring loaded and keeps tight in both directions at stand still.
7. **Separator \*)**  
Removes water and sludge from the oil.
8. **Pressure sensor at separator outlet**  
If the counter pressure after the separator does not reach at least 50 kPa within 35 seconds after start the pump is stopped.
9. **Motorised regulating valve**  
For setting the correct counter pressure in the outlet line (circa 60 - 90 kPa).  
The setting is supervised by the starter / control unit (9).
10. **Hose (3/8") from separator to tank \*)**
11. **Collecting tank (20 litres) \*)**  
Collects the bowl drain oil and the water separated out from the oil (at purification).
12. **Starter/control unit**  
For starting, stopping and supervising the cleaning unit. The main part in the control unit is the PLC (Programmable Logic Computer) which supervises the starting and stopping of the cleaning unit. It also supervises system functions as:  
frequency converters, one for the separator and one for the pump.  
motor load  
bowl hood interlock  
amount of liquid in the collecting tank  
counter pressure at outlet

The red alarm light on top of the Control cabinet (13) indicates if there is any problem with the supervised functions. Detailed information of the problem is presented on the operator panel.  
See [6.3 Alarm light pattern on page 32](#).

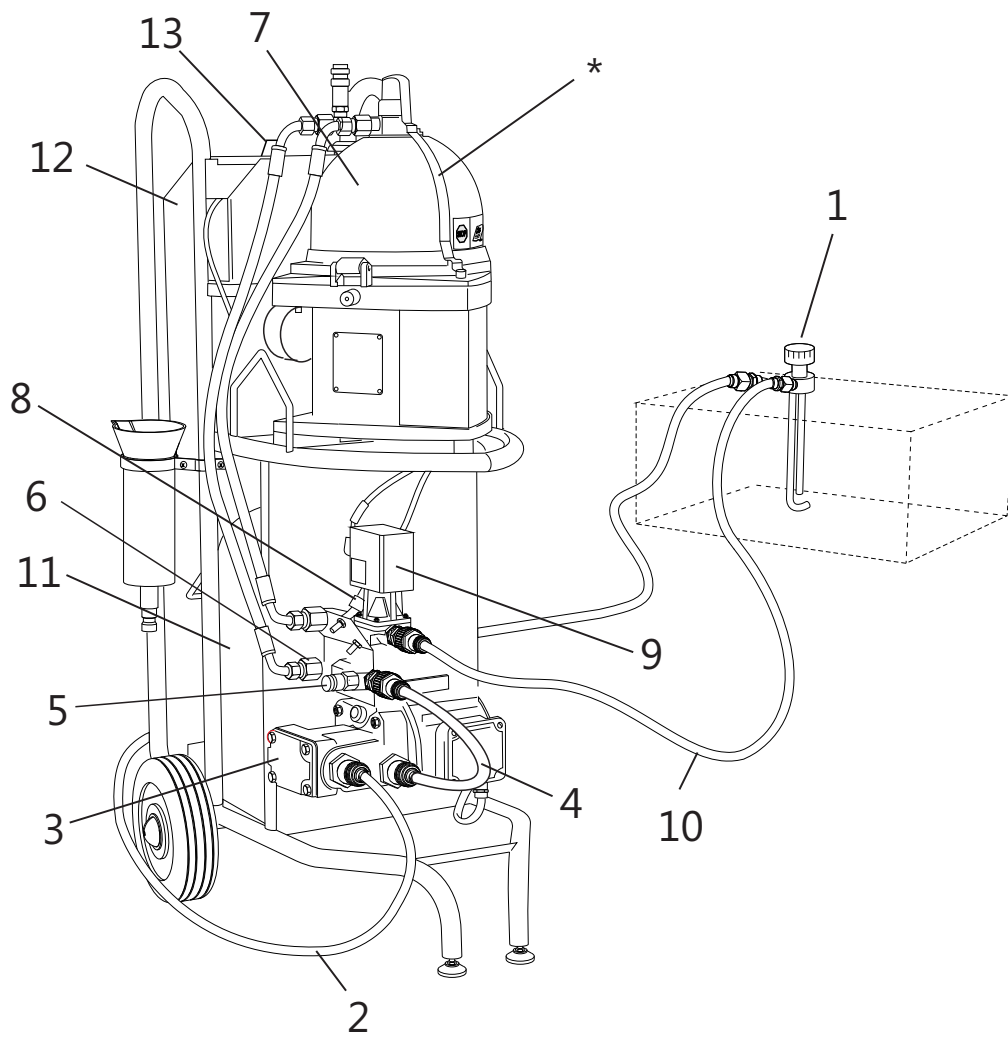

G1115011

## 4.2 Hoses

The hose from the tank to the cleaning unit (cold side) is 1/2" and the hose from the cleaning unit back to the tank (warm side) is 3/8".

### NOTE

When the two coupling halves are fitted into each other, remember to secure the coupling by turning the locking ring until it engages.

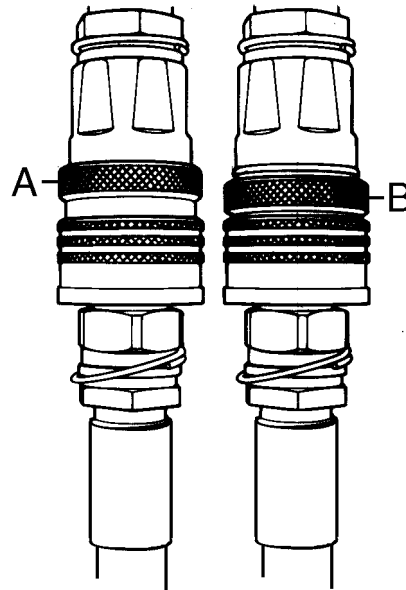

G0906711

- A. Locking ring in unlocked position
- B. Locking ring in locked position

### NOTE

When the coupling halves are disengaged, the protective caps must be fitted to protect the couplings and the oil from impurities.

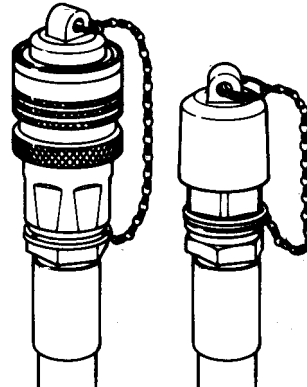

G0906911

When removing the left protecting cap, first pull back the outer ring



### 4.3 Separator

The separator has a bowl hood interlock (3) over the hood (2) and connection housing (1). A magnet (4) in contact with a safety switch indicates if the yoke is in correct position. If not, no power is supplied to the motor. For a description of the separator function, see [5 Working principle of the separator on page 19](#).

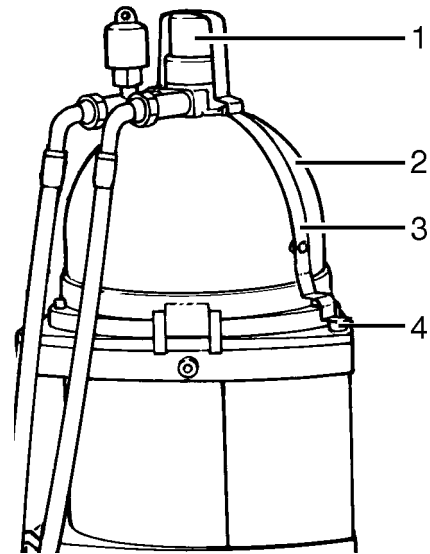

G0907931

### 4.4 Pump

The flow is controlled by the VFD in the control cabinet, see chapter [6 Control Cabinet](#).

### 4.5 Control unit

The Control unit consist of following main parts:

1. Power supply, 24 V DC
2. PLC kit
3. Frequency converter, separator
4. Frequency converter, feed pump
5. Mini terminal
6. Contactor

See chapter [6 Control Cabinet](#).

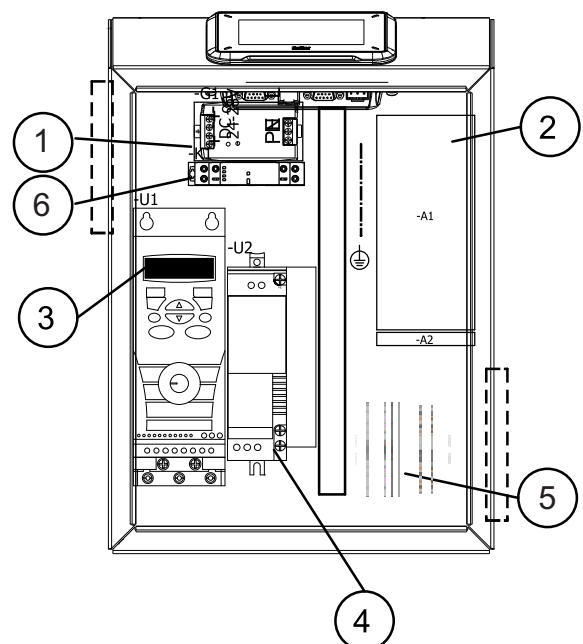

G1115311

## 4.6 Collecting tank

The tank stands on a support under the separator which is held in its upper position by a spring with adjustable tension. The spring can be adjusted by the handle (1) on the underside of the support. When the collecting tank is nearly full the weight will overcome the spring tension and a limit switch is actuated. The signal goes to the control unit which stops the pump. The lamp on the control unit lights up.

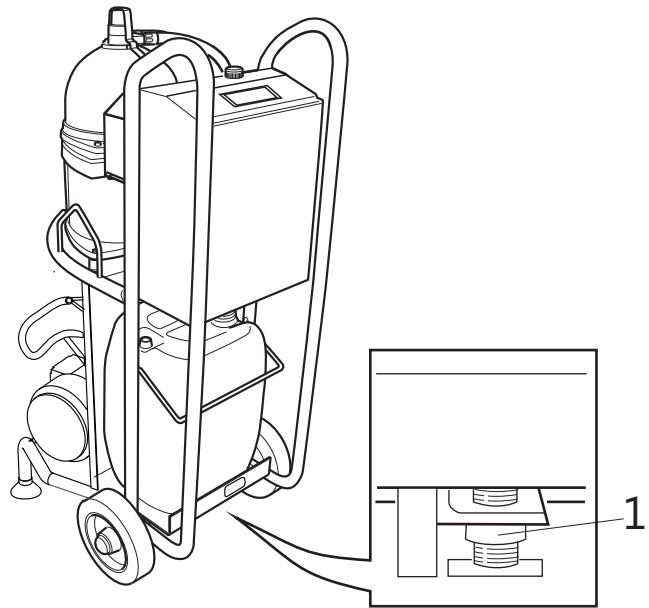

---

# 5 Working principle of the separator

---

## 5.1 Introduction

Separation takes place in a bowl (1), which rotates at high speed generating powerful centrifugal forces.

The speed of the electric motor (6) driving the bowl spindle (3) is controlled by a frequency converter in the control cabinet. The converter also acts as brake when the separator is stopped.

The bowl (1) and motor (6) are suspended on three vibration dampers (5).

If the unseparated oil contains water the separator should be operated as a purifier, otherwise clarifier operation is recommended.

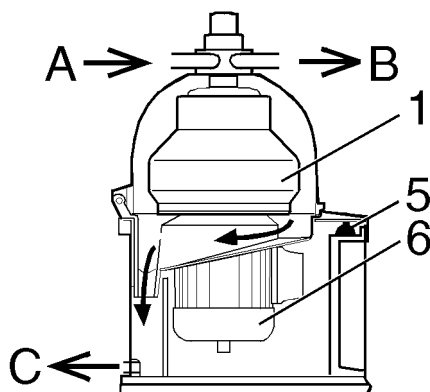

G04505b1

Figure text also valid for illustrations on page [21](#)

1. Bowl
  2. Particles (sludge)
  3. Bowl spindle
  4. Conical discs
  5. Vibration dampers
  6. Electric motor
- A. Dirty oil inlet  
B. Clean oil outlet  
C. Water outlet to collecting tank (purifier operation).  
When the separator is stopped the bowl is drained via this outlet.

**NOTE**

The separator can be operated either as a clarifier or as a purifier.

Choose **clarifier operation** when **no** or only traces of **water** in the oil.

At delivery the separator is assembled for clarifier operation.

Choose **purifier operation** when the oil contains **much water**. The differences between the two modes are further described on next page.

## 5.2 Clarifier operation

The unseparated oil continuously enters at (A) and flows into the bowl (1). The particles (2) are separated and deposited on the bowl wall.

The cleaned oil is forced inwards to the centre of the bowl and up to a paring disc (not illustrated). Since the oil is rotating, the stationary paring disc acts as a pump which forces the oil out through outlet (B) under a constant pressure.

The particles accumulated on the bowl wall are removed periodically (every 1-3 days) by hand.

## 5.3 Purifier operation

When operating the separator as a purifier a water seal must be established before the oil feed is started. If not, oil will flow out through the water outlet (C). Procedure is described in [7.4 Start](#).

Otherwise the separation principle is similar to clarification except that the separated water, which is heavier than the oil, leaves through the underside of the bowl at (C) down into the collecting tank.

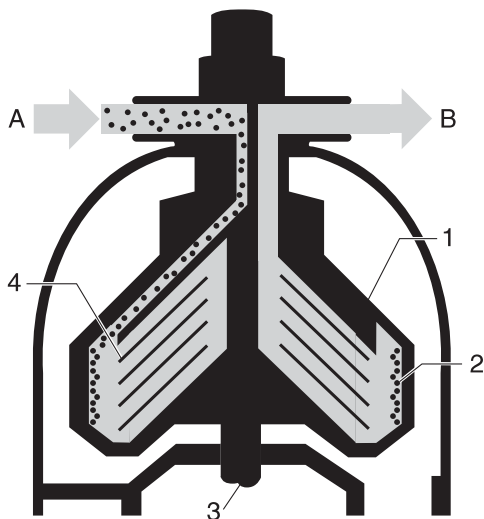

G0519251

*Clarifier bowl*

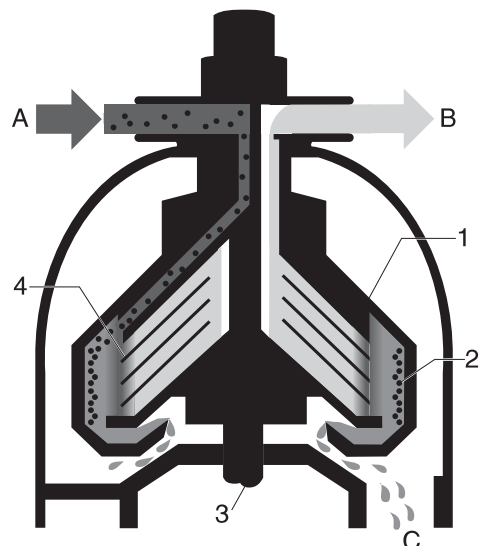

G0519241

*Purifier bowl*

## 5.4 Changing operation mode

When changing operating mode from clarifier to purifier, or vice versa, proceed as follows:

1. Dismantle the separator in the same way as when cleaning the bowl, see [9.4.2 Cleaning of bowl on page 56](#).
2. Remove the level ring, O-ring, lower part of paring chamber and the sleeve with wings.

3. Unscrew the centre screw.

4. Lift out the bowl insert. If it is difficult to get the insert loose from the bowl spindle, remove the splash guard (the white plastic ring) to get a better grip on the bowl bottom.

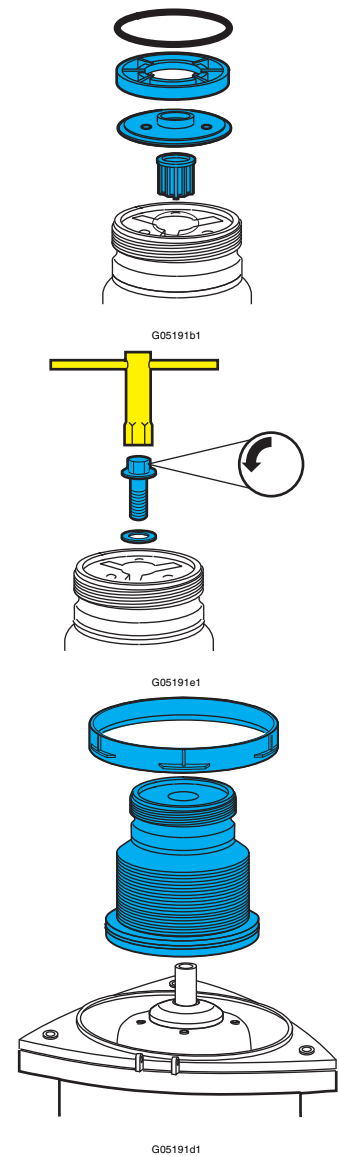

5. Exchange one insert for the other.

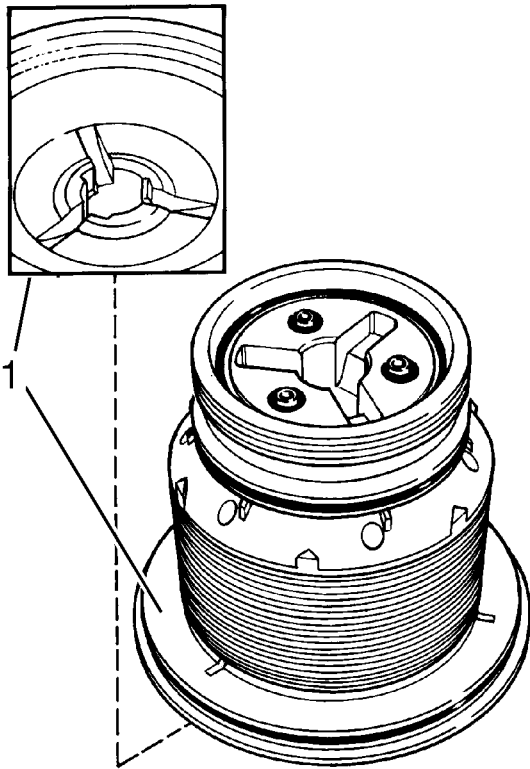

G1114311

*Clarifier bowl insert*

1. Bowl bottom (clarifier)

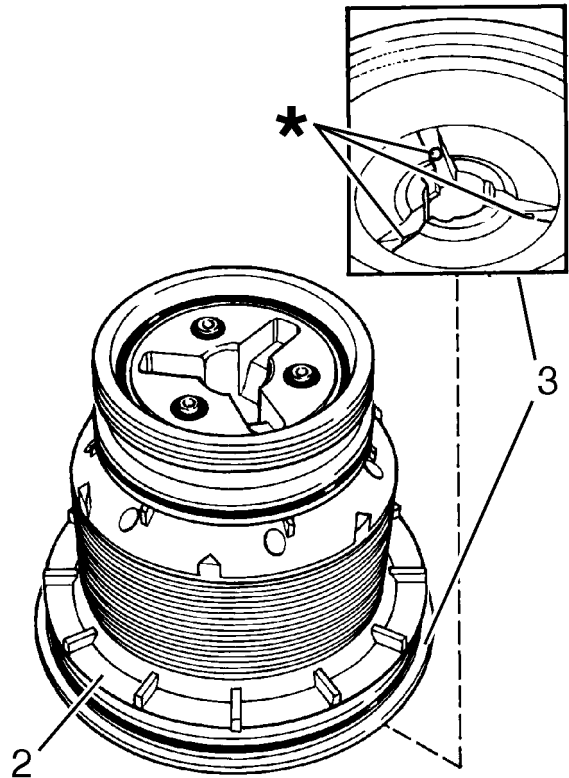

G1114411

*Purifier bowl insert*

2. Bottom disc (purifier)
3. Bowl bottom (purifier) with three holes (\*)

6. When fitting the insert, check that the cylindrical pin (1) in the shaft is not missing. Check that the pin enters the guide in the bottom of the insert.

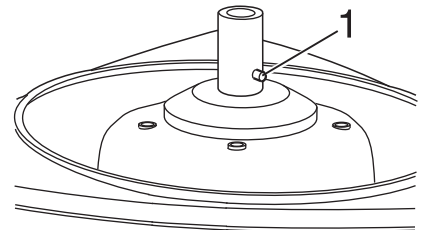

G0907011

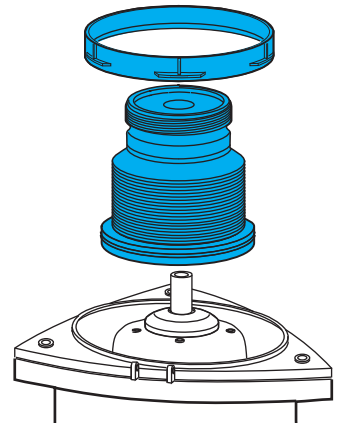

G05191d1

## 5 Working principle of the separator

---

7. Tighten the centre screw.  
Check that **one** washer is fitted under the screw.

8. Fit the sleeve with wings, lower part of paring chamber, level ring and O-ring.

### NOTE

See the instructions in [9.4.2 Cleaning of bowl](#) for fitting the level ring and O-ring correctly. These pages also describe the rest of the assembly of the separator.

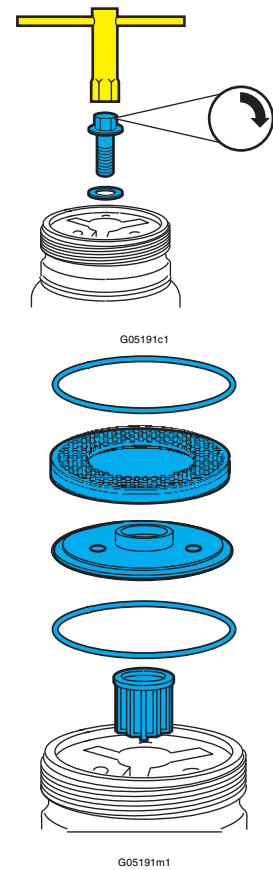



# 6 Control Cabinet

The operator panel is a 4" touch screen placed on top of the control cabinet. Do not use metal or any sharp objects to operate the panel. A stylus pen or similar however, can be used.

Inside the control cabinet there are two frequency converters for regulating the speed of the separator and the pump, a 24VDC power supply and a PLC.

There are no operator controls inside the cabinet, so it should not be opened. Qualified personnel only are allowed to open the cabinet.

On top of the cabinet there is also an alarm light. It is used to indicate the status of the unit. See [6.3 Alarm light pattern on page 32](#).

## 6.1 Operator panel

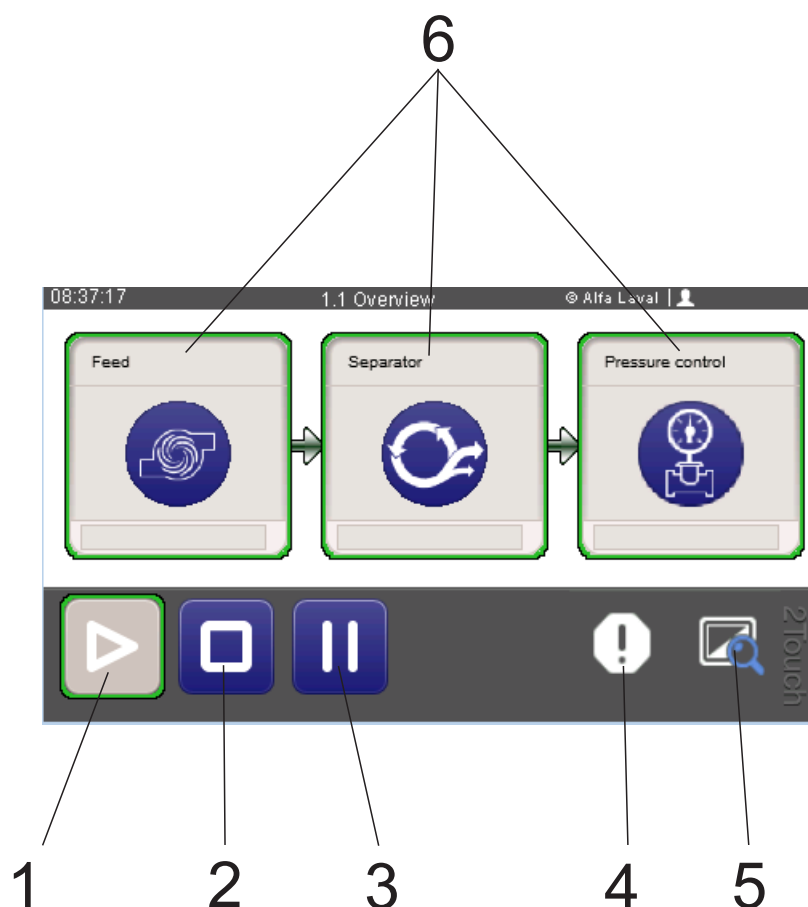

G1113881

- |                   |                                 |
|-------------------|---------------------------------|
| 1. Start button   | 4. Alarm button                 |
| 2. Stop button    | 5. Dynamic Back/Overview button |
| 3. Standby button | 6. Sub-equipment tiles          |

### Control bar

The control bar is always visible at the bottom of the screen.



G1101211

Start, Stop and Standby buttons are blue when they are accessible, and grey when they are not. When an operating mode is active the corresponding button is circled in green.

The Alarm button takes the operator directly to the Alarm list (see “Alarm list” on page 30). If there is an active alarm the button will be red.

The Back/Overview button has different functions depending of which screen is displayed. If **Back** is displayed the button will switch to the previous screen.



G1101221



G1116691

If **Overview** is displayed it will switch to the overview screen.

## Tiles

The startup screen contains three tiles, each representing a sub-equipment of the unit. When a sub-equipment is running the corresponding tile will be circled green.

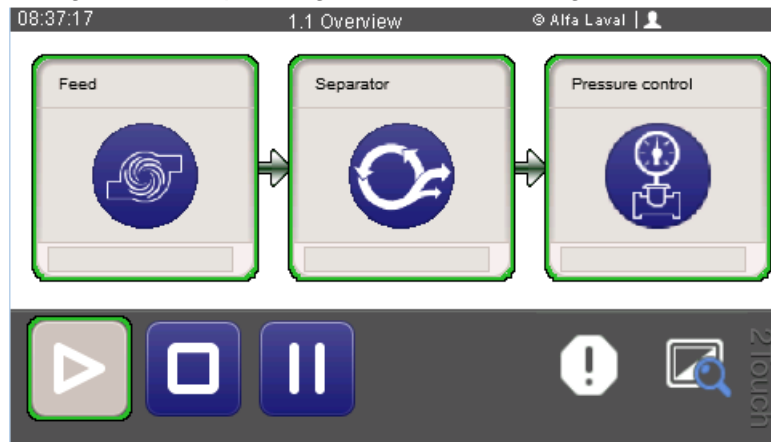

G1113811

Tapping a tile will display an overview of all devices within that sub-equipment.

On the left hand side there is a status row for the sub-equipment and if applicable, setpoints for the devices and control functions for that subequipment.

On the right hand side is a graphical overview of the sub-equipment. Each device is circled green if running or open, and red if an alarm exists for that device. Actual values, such as pressure readings and speed, are displayed next to the device.

## Feed

The **Feed** screen shows the feed pump.

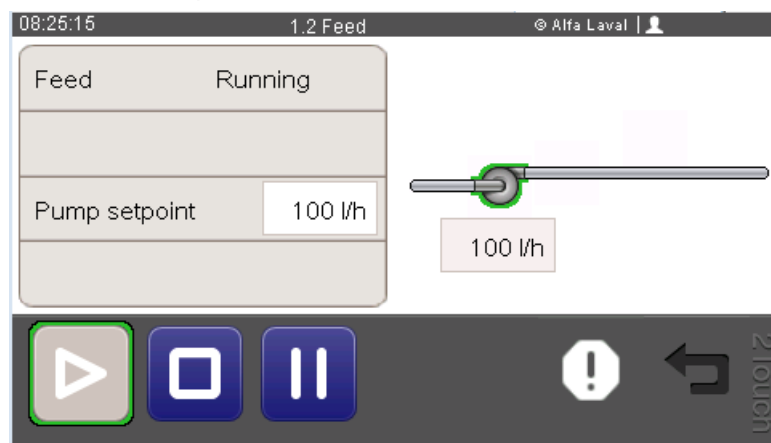

G1113821

### Separator

The **Separator** screen shows the separator motor, the bowl hood interlock and the tank limit switch. A trip counter for batch running time is available.

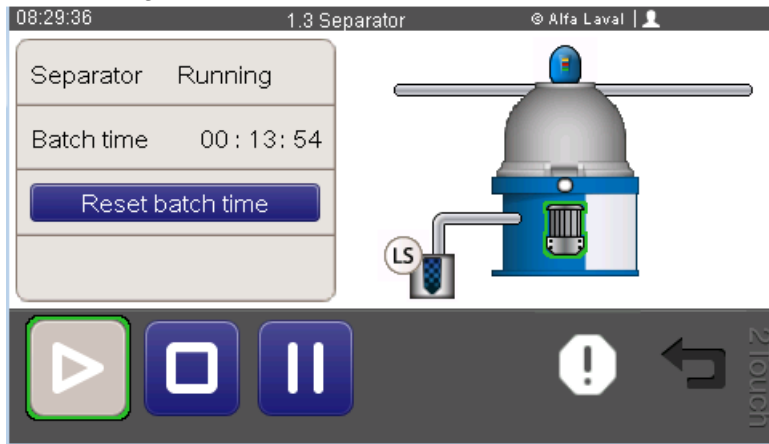

G1113831

### Pressure control

The **Pressure control** screen shows the pressure sensor and the pressure regulation valve. Pressure set-point can be changed from here. By tapping the set-point value a touch dial will appear.

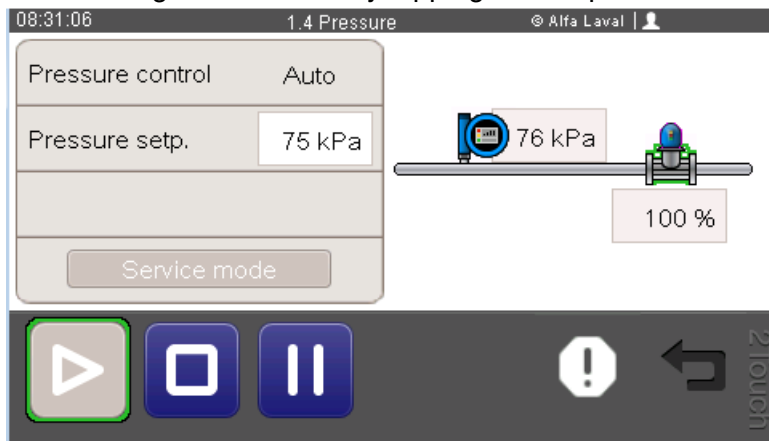

G1113841

When the unit is at standstill, the operator can switch to Service mode and enable manual control of the regulating valve. This is only intended as an operational test of the valve. It cannot be used when the unit is running.

## Overview

By tapping the **Overview** button the Overview screen is displayed.

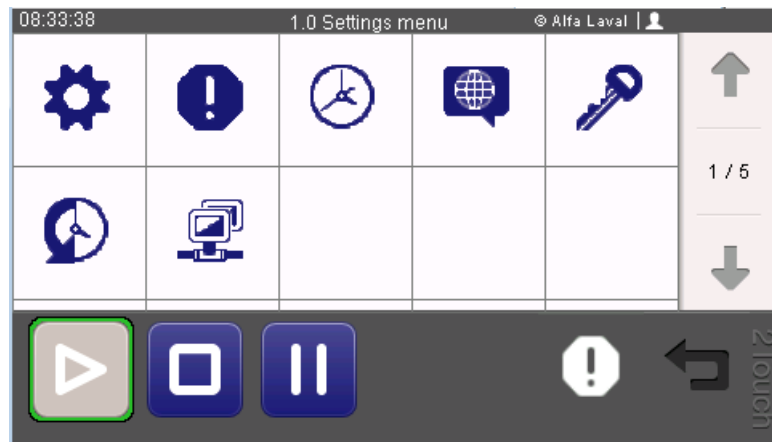

G1113851

From there the operator is given access to the following screens (starting on the top left hand side):

### Parameters

Configuration of the system. Only possible to change values when logged in as Administrator.

### NOTE

Administrator access level is only for Alfa Laval service engineers.

### Alarm history

A list of all past alarms

### System time

Set system time so correct time stamps are made in the alarm list.

### Language

Set system language.

### Login

Login and logout to change access level.

### Operating timers

Separate running timers are available for System, Separator motor, Feed pump motor and Regulating valve.

### System overview

Status of the control system; program versions, used RAM, internal temperature, etc.

**Alarm list**

The Alarm list shows all active and all unacknowledged alarms. It is always accessible from the Control bar.

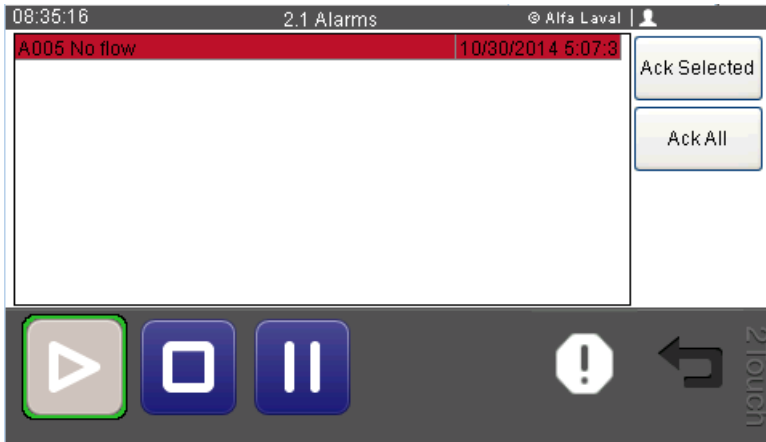

G1113861

Alarms can be for operator information only but in most cases it also forces the unit to another operating mode. See “6.4 Alarm table” on page 33.

The operator acknowledges alarms with the two buttons on the right hand side.

Red indicates an unacknowledged alarm, yellow an acknowledged but still active alarm and green an unacknowledged but no longer active alarm.

## 6.2 Connection for correct voltage

### NOTE

If the power supply is equipped with an ELCB (Earth Leakage Circuit Breaker) make sure that it is of industrial type that allows higher (30mA at 230 V) leakage current.

If the cleaning unit should be connected to other voltage than 230 V, the unit should be equipped with a transformer (1). Other possible voltages are then 100, 110 and 120 V.

Switching between voltages requires changing of transformer connection inside the control cabinet. See circuit diagram. This should only be done by qualified personnel.

If a transformer is connected, first check that the power cable is correctly connected in the control unit before operating the cleaning unit. For further information, see chapter *Electrical system*.

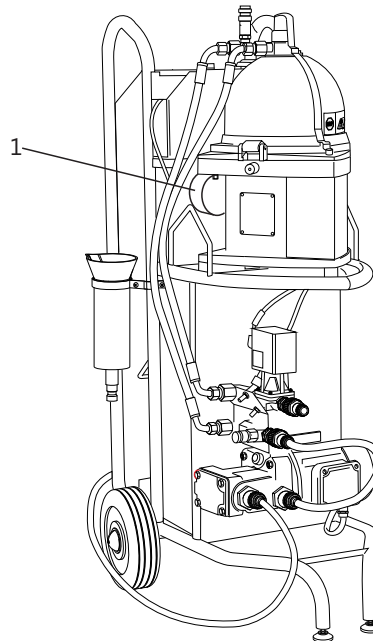

G1113311

*Location of transformer (1) if fitted*

### 6.3 Alarm light pattern

Off	<ul style="list-style-type: none"><li>- In STOP when separator is in standstill</li><li>- In PRODUCTION</li></ul>
Steady shine	<ul style="list-style-type: none"><li>- During START</li><li>- If an active alarm that has been acknowledged exists</li><li>- During STOP as long as separator is not in standstill</li></ul>
Blinking (0.5s on, 0.5s off)	<ul style="list-style-type: none"><li>- When feed pump speed is boosted (Startup speed)</li><li>- If an unacknowledged alarm exists</li></ul>
Flashing (0.2s on, 2s off)	<ul style="list-style-type: none"><li>- If system is in STANDBY and no alarm is active</li></ul>



## 6.4 Alarm table

Alarm	Alarm delay	Description	Action
A001 Low counter pressure	15s	Too low counter pressure.	See <a href="#">8.3 Pump stops on page 47</a> .
A002 Startup pressure	35s	Too low startup pressure.	See <a href="#">8.3 Pump stops on page 47</a> .
A003 Pressure sensor out of range	5s	Signal out of range on PT.	Check sensor cable. Replace sensor.
A004 Max time in Standby	N/A	Maximum time in STANDBY (180 min) exceeded.	Restart the cleaning unit.
A005 No flow	60s	No flow, regulator valve closed for too long.	See <a href="#">8.8 No flow from pump on page 49</a> .
A006 High temp cabinet	15s	High temperature in control cabinet	Check ventilation for control cabinet.
A100 Feed pump motor overload	1s	Frequency converter fault for feed pump.	Check motor connection. Check pump motor. Check control cables to Frequency converter.
A200 Bowl hood interlock open	1s	Bowl hood interlock out of correct position.	See <a href="#">8.1 Cleaning system/separator does not start or stops shortly after start on page 47</a>
A201 Oil tank full	5s	Collecting tank full.	Empty the tank and start the pump.
A202 Separator motor overload	1s	Frequency converter fault for separator.	Check separator motor connection. Check separator motor. Check control cables to Frequency converter.
A300 (For Alfa Laval Emmie with heater only) Heater overheat	5s	Alarm only	



---

# 7 Operating instructions

---

## 7.1 Separation time

It is recommended that the oil volume (V) in the complete system, not only the tank volume, is separated at least five times. The separation capacity will normally be adjusted to about 100 litres per hour. Calculate the minimum running time (T) by using the adjacent formula.

$$T = (V \times 5)/100$$

T = Minimum running time

V = Volume in complete system (in litres)

*Formula for calculating minimum separation time*

### NOTE

If separating emulsified oil it could be necessary to separate the total volume up to 10 - 15 times.

## 7.2 Separation mode

### Introduction

To learn the correct running strategy, first read the information below carefully before starting the separation process.

1. Decide if the separator will be operated as clarifier or purifier. The difference between them is described in chapter [5 Working principle of the separator](#).  
At delivery the separator is assembled as a clarifier.
2. If the amount of water and sludge in the oil is unknown, start the separation in clarifier mode (change of operation mode is described in chapter [5.4 Changing operation mode on page 22](#)).  
Run for 1 - 2 hours.

### Control of water content

Stop the separator. Move the hose outlet (1) from the collecting tank to the filler cup (2) and drain the content (about 1 litre).

Pour over the content to a glass bottle or similar to check the water content. If water is found, operate the separator as a purifier.

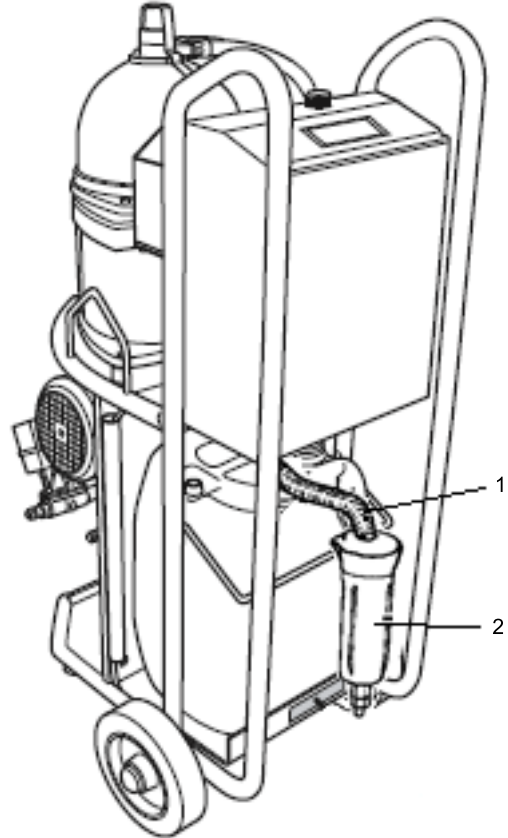

### Control of sludge content

Dismantle the separator and measure the thickness (A) of the sludge collected on the bowl wall, see [9.4.2 Cleaning of bowl on page 56](#). The thickness should never exceed 10 mm.

Max. recommended cleaning interval is 3 days. A longer interval can result in a sludge cake that is hard and difficult to remove. Too long interval can also result in that sludge enters the disc stack and hinders separation. Oil overflow and vibration can also occur.

When cleaning very contaminated oil, bowl cleaning every 20 - 30 minutes could be necessary.

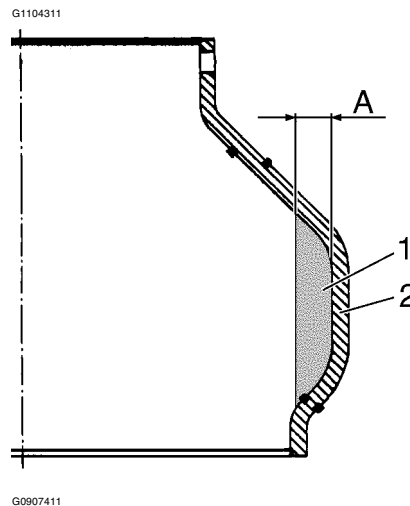

- A. Max. thickness = 10 mm (corresponds to 0.6 litre)
- 1. Sludge
- 2. Bowl wall

## 7.3 Before start

1. Make sure that the pump is fully primed. Connect the inlet tube to the pump with the suction pipe and pour oil into the pump as illustrated.
2. Connect the hoses as described in chapter 4 [Description of main parts](#). Make sure that the hoses to the pump are correctly connected.

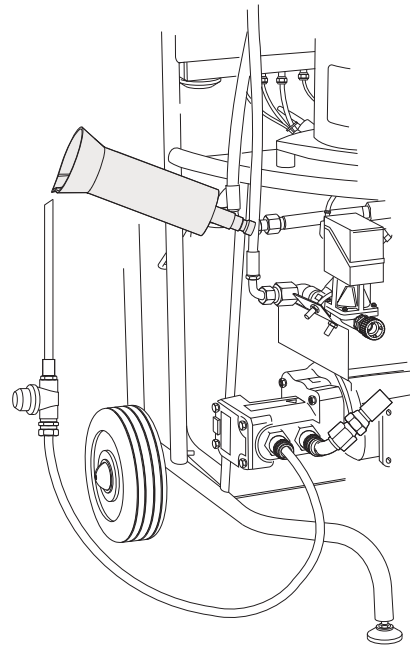

G0978741

3. The separator is set up as clarifier when delivered. In case purifier mode is needed, please convert the bowl as described in chapter [5.4 Changing operation mode on page 22](#)
4. Never start the separator with sludge remaining in the bowl.



### **Disintegration hazard**

**Unevenly spaced sludge cake will result in heavy vibration with possible damage to the separator.**

5. When using the unit onboard a ship, first fasten it firmly with straps (A) or similar to fixing points.

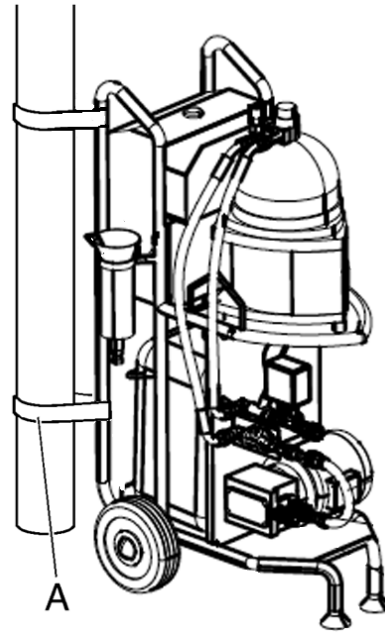

**NOTE**

Never separate an unfiltered system without a strainer fitted to the pump inlet. In such a case, use the special suction pipe with the built-on strainer.

**NOTE**

Do not connect the return outlet to a pressurized system with the same or higher pressure than the pressure switch set point (50 kPa). Otherwise the safety function of the switch will be overridden, which implies that the pump can operate without flow.

6. Connect the power cable to the mains. See also information in chapter [10 Technical data on page 67](#).

**NOTE**

Be sure the mains fulfil the voltage requirement. The frequency converter fitted in the control cabinet will cut off the power at voltage spikes or at too high/low voltage ( $\pm 10\%$ ).

G1104611

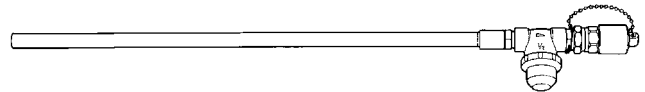

G0912421

Suction pipe (1/2") with built-on strainer

7. Make sure that the three hood screws (3) and the knob (1) are firmly tightened and that the bowl hood interlock (2) is in closed (vertical) position.

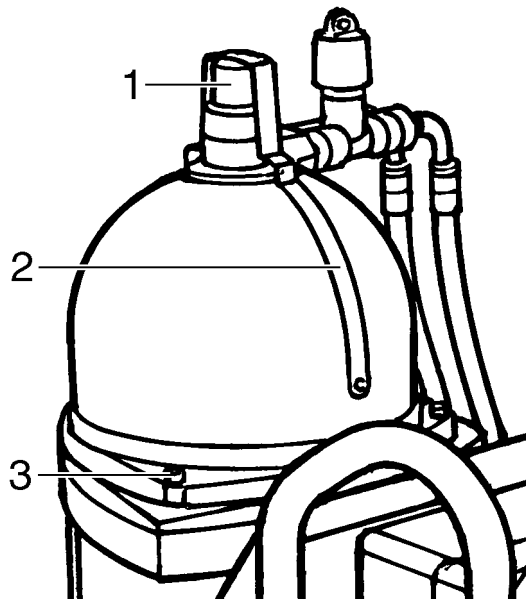

G0908811

## 7.4 Start

1. Connect the unit to the power supply.

### NOTE

If the power supply is equipped with an ELCB (Earth Leakage Circuit Breaker) make sure that it is of industrial type that allows higher leakage current.

### NOTE

The unit must be connected to an earthed outlet.

2. When all alarms are acknowledged, the operator can tap the Start button and the cleaning unit will start. The separator starts.

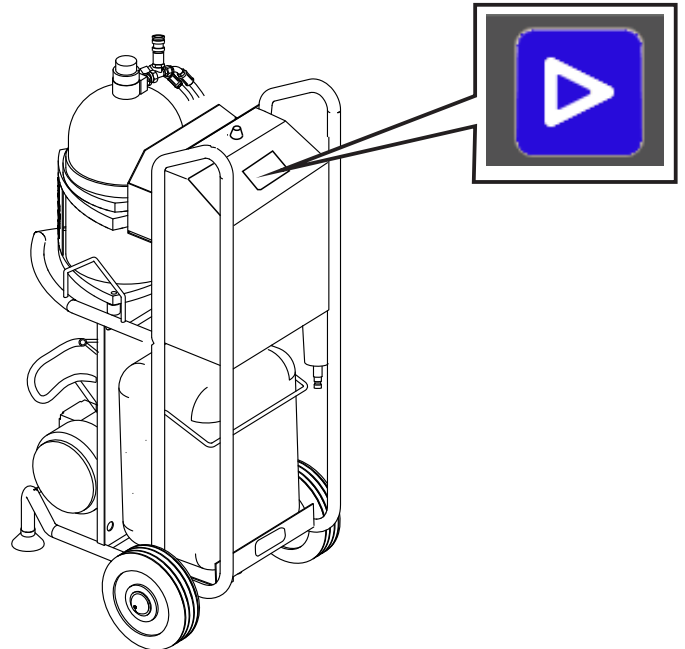

G1107911

3. **For purifier mode only!**  
(Purifier mode is described in [5 Working principle of the separator on page 19](#)).

Before start, fill the filler cup with water. When the text on the display indicates “For purifier mode add water”, add the water to the separator by opening the valve (1).

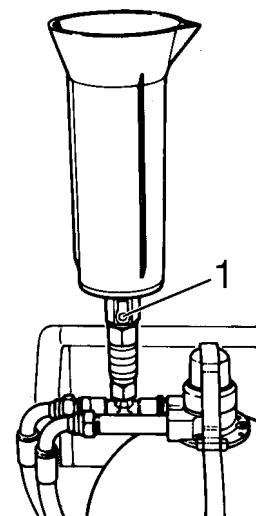

G0906111



When the filler cup is empty, close the valve, remove the filler cup and fit the protective cap (1) onto the connection.

#### NOTE

The filler cup must be removed in order to avoid vibration.

The feed pump starts automatically

When the separator has reached full speed the feed pump starts. The control system waits for the pressure to rise. When the pressure has reached the setpoint (see tile menu for pressure under [6.1 Operator panel](#)), the feed pump speed decreases to separation speed and the automatic pressure regulation starts.

The cleaning unit is now running in Production mode.

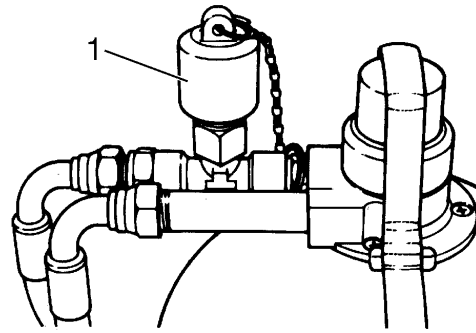

G0906211

#### NOTE

Make sure that oil is available when starting the pump. Running dry for a longer period can damage the pump.

#### WARNING

##### Disintegration hazard

Some vibration can occur for short periods during the start phase when the separator passes through the critical speed. This is normal and passes over without danger. If the vibrations become very severe or continue at full speed, **stop the separator immediately**. See [8.6 Separator vibrates on page 49](#) for possible causes.

#### NOTE

Make sure that oil is available when starting the pump. Running dry for a longer period can damage the pump.

4. Evacuate air. Press the valve until oil is leaking.

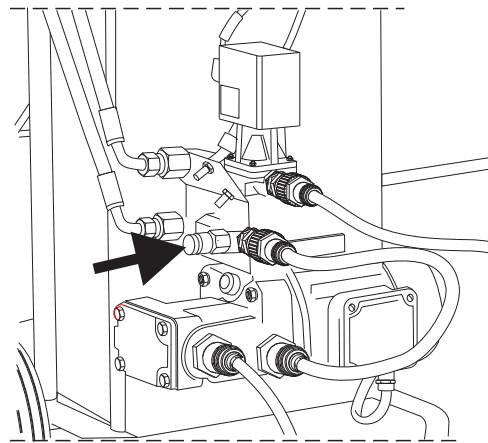

G09787x1

5. When the oil starts to flow through the separator the counter pressure will increase and regulation starts. The counter pressure is increased to the latest set value  $\pm 10\%$ .

If the counter pressure does not reach 55 kPa within one minute the pump will stop. See [8.3 Pump stops on page 47](#)

6. To restart the feed pump, acknowledge alarm and tap start button.

### NOTE

**Make sure that oil is available when starting the pump. Running dry for a longer period can damage the pump.**



G1106011

7. When oil starts to flow through the pump the counter pressure will increase.

### NOTE

**If the counter pressure is higher, this could indicate that the return hose is connected to a pressurized system with excessively high counter pressure. This is not permitted. The safety function of the pressure switch will be overridden allowing the pump (and heater if mounted) to operate without flow.**

### NOTE

**If the separator stops during this sequence (normally because power consumption too high), see [8.4 Separator stops on page 48](#).**

**NOTE**

If the pump starts to emit cavitation noise (e.g. when the oil is of high viscosity or cold) turn the screw anti-clockwise to increase the internal leakage, which will eliminate the cavitation.

9. The desired value can be entered, see [6 Control Cabinet](#).

To check the actual flow, proceed as follows:  
When the oil temperature has reached the set point, check the throughput of the separated oil. 100 - 120 l/h is recommended. With this flow the enclosed filler cup will be filled within 35 - 40 seconds. Proceed as follows:

- Stop the pump.
- Loosen the return hose fitted to the oil tank and connect the special return pipe.
- Start the pump and fill the cup.
- When the cap is filled, stop the pump and pour the oil back into the oil tank.
- Start the pump.

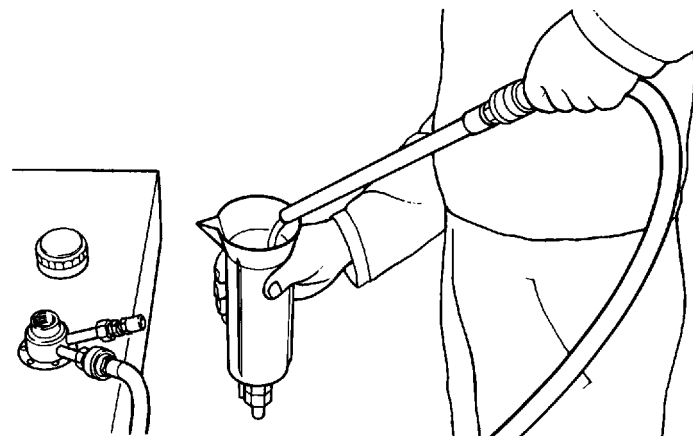

G0912611

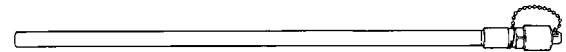

G0912431

*Return pipe*

## 7.5 Operation

1. Check the cleaning unit for correct operation (temperature, counter pressure and vibration). This is especially important the first time the cleaning unit is run after installation or dismantling and assembly.



g1106311

*Recommended counter pressure is 60 – 90 kPa*

### 2. For purifier mode only!

Check that no oil is leaking out via the water outlet (1). Preferably use a torchlight for checking. If leakage is occurring, see [8.11 Some liquid escaping through drain outlet to collecting tank on page 51](#).

3. When the collecting tank is nearly full, the pump is stopped automatically and the lamp on the control unit lights up. Empty the tank and restart the pump to continue the cleaning. It is possible to recover any oil by proceeding as described in [4.6 Collecting tank on page 18](#).

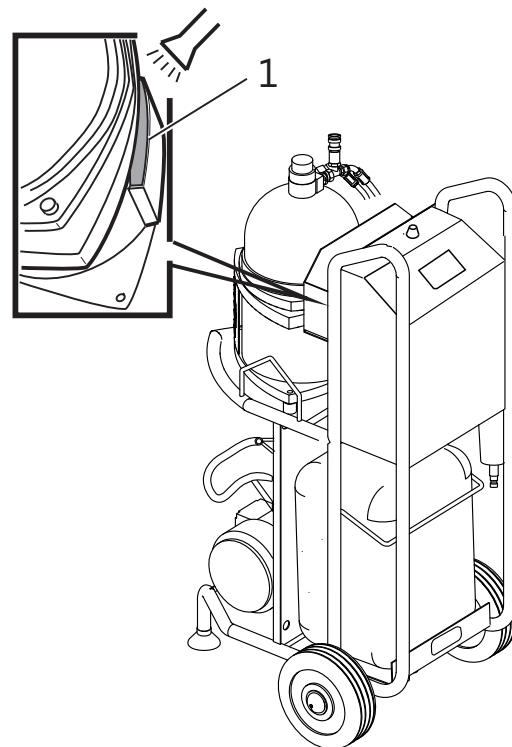

g1108011

## 7.6 Standby

If an alarm occurs in Production mode, the system goes into Standby mode. The feed pump is stopped and the pressure regulating valve is opened. The operator can also choose to go to Standby by tapping the Standby button. When there are no alarms active and unacknowledged, the operator can tap the Start button to resume separation by returning to Production mode.

### NOTE

**If an alarm has forced the system into standby, never do more than one pump restart. Check and remedy the cause. Several restarts can damage the pump, which can also result in damage to the pump housing and/or motor.**

## 7.7 Stop

1. The cleaning unit is stopped by tapping the Stop button, or if an alarm forces the system to stop. Feed pump and separator are turned off. Pressure regulating valve is opened.

### NOTE

After each stop of the cleaning unit, the separator bowl must be cleaned well. If not, an unevenly spaced sludge cake will at next start result in heavy vibration and can cause damage.

2. When the separator has stopped, disconnect the hoses.

### NOTE

If the check valves are not sealing properly, there is a risk that oil may be siphoned from the hydraulic oil tank and drained via the separator into the collecting tank.

### NOTE

When the separator has nearly stopped rotating (within two minutes), the liquid content of the bowl will be drained by gravity into the collecting tank.

### NOTE

If the position of the tank level is higher than the inlet/outlet of the separator, there is a risk that liquid may be siphoned from the tank and drained via the separator into the collecting tank.

### NOTE

If the cleaning unit is not used for a longer period drain the pump from liquid.



g1106211

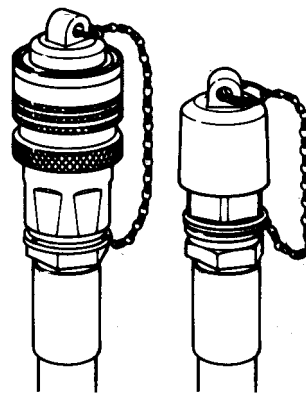

g0906911

## 7.8 How to drain hoses

It is possible to drain the hoses (not the hoses from pump to separator and from separator to tank) by switching them in following way:

1. Stop the unit.
2. Switch the hoses fitted at the pump outlet (1) and inlet (2).
3. Start the unit.
4. When the pump is started press the bleeding valve (3) to allow air to enter the heater.

The hoses will be drained. If possible check the oil flow.

If there is still oil in the system when the pump is stopped after one minute start the system again.

Stop the system.

### NOTE

Switch back the hoses after draining.

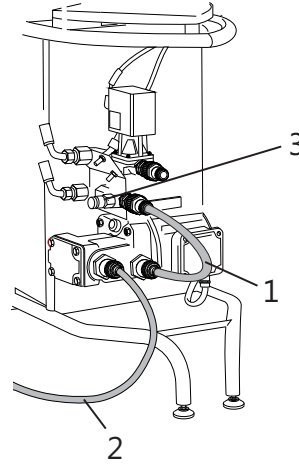

g1115111

*Hoses connected to pump are swapped*

1. Pump outlet
2. Inlet
3. Bleeding valve

---

# 8 *Trouble shooting*

---

## 8.1 Cleaning system/separator does not start or stops shortly after start

Possible cause	Action
No power supplied	Check the mains switch, fuses and supply line
Bowl hood interlock is not in correct position	Position the interlock correctly
Defective magnetic switch indicating the position of the bowl hood interlock	Check that the switch opens and closes when interlock is moved up and down
Incorrect assembly after cleaning. The bowl and motor shaft cannot rotate freely	Dismantle and check
Voltage protection for frequency converter trips because of too low/high voltage or voltage spikes greater than $\pm 5\%$ .	Check the voltage. If unstable voltage, connect a transformer.
Separator stops	See <a href="#">8.4 Separator stops on page 48</a> .
Pump stops	See <a href="#">8.3 Pump stops on page 47</a>

## 8.2 Pump does not start

Possible cause	Action
Microswitch for filled collecting tank activated	Empty the tank or adjust the spring tension for the tank support

## 8.3 Pump stops

Possible cause	Action
Collecting tank filled	Empty the tank and start the pump
Overload caused by clogged strainer	Clean the strainer. The motor protector in control unit is automatically reset
Counter pressure at separator outlet is lower than 50 kPa	<ul style="list-style-type: none"><li>• Check that suction inlet is not above surface in tank</li><li>• Check for obstructed inlet line</li><li>• Check function of regulating valve</li><li>• Adjust the counter pressure. See chapter <a href="#">6 Control Cabinet</a></li><li>• Check the direction of rotation for separator and pump</li></ul>
Overload caused by obstructed inlet or outlet side	Check that the feed through the whole system is sufficient

Possible cause	Action
Voltage protection on frequency card trips because of too low/high voltage or voltage spikes	Check the voltage. If unstable voltage, connect a transformer.
Defective motor/frequency converter	Remedy - replace

## 8.4 Separator stops

Possible cause	Action
Overload due to high throughput	Reduce the flow rate
Overload due to high viscosity	Reduce the flow
Bowl hood interlock out of correct position	Reposition the interlock
Overload due to clogged disc stack	Clean the separator disc stack
Overload due to incorrect assembly	Check the bowl assembly
Tripped frequency converter due to too low or too high supplied voltage ( $>\pm 5\%$ of nominal voltage)	Check the voltage. Check the voltage. If unstable voltage, connect a transformer.
Also see possible causes and actions in <a href="#">8.1 Cleaning system/separator does not start or stops shortly after start on page 47</a> .	
Defective frequency converter card	Replace card in control cabinet.
Counter pressure too high	Reduce counter pressure.

## 8.5 Noise

Possible cause	Action
Cavitation in pump	Reduce the flow. See chapter <a href="#">6 Control Cabinet</a>
Vibration dampers in separator are worn	Fit new dampers
Incorrect assembly of separator bowl	Dismantle and check
Bearings damaged	Fit new bearings



## 8.6 Separator vibrates



### Disintegration hazard

If excessive vibrations occur, **STOP** the separator

Possible cause	Action
Bowl out of balance due to: <ul style="list-style-type: none"> <li>• Insufficient or incorrect cleaning (sludge in disc stack)</li> <li>• Unevenly spaced sludge cake (bowl not cleaned prior to start)</li> <li>• Incorrect assembly</li> </ul>	Dismantle and clean the separator bowl. Be sure that the separator is assembled correctly.
Vibration dampers in separator are worn	Fit new dampers
Damaged bearings	Replace the bearings

## 8.7 Insufficient separation result

Possible cause	Action
Separator disc stack clogged	Clean separator bowl and disc stack
Too high flow rate	Reduce the flow by adjusting the screw fitted in pump. Check that counter pressure is correct.

## 8.8 No flow from pump

Possible cause	Action
Incorrect setting of flow control (too low speed of pump)	Start with max. flow. See <a href="#">6 Control Cabinet</a> .
The screw fitted in pump is not closed (internal leakage too high)	Turn the adjustment screw clockwise.
Air leakage on suction side between tank and pump	Check that the inlet is below surface in tank. Check that couplings are correctly fitted.

## 8.9 Flow too low

Possible cause	Action
Low feed flow	Increase the flow. Check for correct counter pressure.
Counter pressure at outlet too high	Reduce the counter pressure with the regulating valve (60 - 90 kPa is recommended)
Leakage caused by incorrect assembly	<ul style="list-style-type: none"> <li>The three screws fastening the bowl hood or the paring disc knob (the upper part of the separator) are not completely tightened.</li> <li>Dismantle and check the separator bowl parts. Especially check that no O-rings are missing, are defective or incorrectly fitted. Ensure that the separator is assembled correctly.</li> </ul>
Separator or pump rotates in wrong direction	Check power supply cables.

## 8.10 No flow either through clean oil outlet or through drain to collecting tank

Possible cause	Action
No open inlet at suction end (closed check valve in hose connection)	Fit suction pipe or similar
Separator or pump stopped	Check function
Inlet and outlet hoses for pump wrongly connected	Swap the hose connections
Strainer in inlet pipe clogged	Clean strainer

## 8.11 Some liquid escaping through drain outlet to collecting tank

Possible cause	Action
Counter pressure at outlet too high	<ul style="list-style-type: none"> <li>Reduce the counter pressure with the regulating valve (60 - 90 kPa is recommended)</li> <li>Reduce the flow</li> </ul>
Clogged disc stack	Clean the bowl and disc stack
If operating in purifier mode: Insufficient sealing between bottom disc and bowl bottom in separator (O-rings may be missing)	Dismantle and check the separator bowl. Be sure that the separator will be assembled correctly.
The three screws fastening the bowl hood or the paring disc knob (the upper part of the separator) are not completely tightened, causing leakage	Tighten the screws and /or the knob

## 8.12 Oil flow through drain outlet to collecting tank only

Possible cause	Action
If operating in purifier mode: broken liquid seal in separator bowl	<ul style="list-style-type: none"> <li>Stop the pump and add water through the inlet at top of the separator.</li> </ul>
Obstruction in cleaned oil feed line	<ul style="list-style-type: none"> <li>Check that regulating valve is open</li> <li>Check that outlet end to tank is open (no closed check valve in hose connection)</li> </ul>

## 8.13 Oil leakage through drain outlet to collecting tank when separator is not running

Possible cause	Action
Oil is siphoned from oil tank due to siphon effect	Disconnect both hoses connected to the oil tank
Leaking check valve (at inlet and/or outlet side)	Replace

## 8.14 Collecting tank overflowing but pump does not stop

Possible cause	Action
Adjustment of the spring tension for the tank support is incorrect	Adjust the setting. See description in <a href="#">4.6 Collecting tank on page 18</a> .

## 8.15 Separation temperature too low

<b>Possible cause</b>	<b>Action</b>
Throughput too high	Reduce the flow

---

# 9 Maintenance

---



## Entrapment hazard

Switch off the power supply, remove the electric cables from the sockets and make sure that rotating parts have come to a **complete standstill** before starting any dismantling work.



Never use cleaning agents with a pH below 6 or above 9 as they can damage the metal surfaces.

## 9.1 Cleaning

### 9.1.1 Separator

The separated solids collected inside the separator bowl must be removed manually. The length of the cleaning interval depends on the liquid flow rate and on the amount of solids. During the initial period, open and inspect the bowl once a day to determine the necessary cleaning interval. The bowl must be cleaned before the solids layer has become thicker than 10 mm. Otherwise there will be risk that the clean liquid outlet in the bowl will be covered by solids.

**Control of sludge content**

Dismantle the separator and measure the thickness (A) of the sludge collected on the bowl wall. The thickness should never exceed 10 mm.

If the interval between bowl cleaning is too long, this can result in a sludge cake that is hard and difficult to remove. Too long interval can also result in that sludge enters the disc stack and hinders separation. Oil overflow and vibration can also occur.

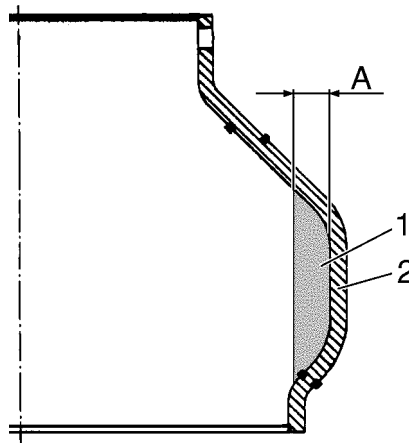

When cleaning very contaminated oil, bowl cleaning every 20 - 30 minutes could be necessary.

- A. Max. thickness = 10 mm (corresponds to 0.6 litre)
- 1. Sludge
- 2. Bowl wall

See [9.4.2 Cleaning of bowl on page 56](#) for information on procedure.

For further information, see [7.2 Separation mode on page 35](#).

**9.1.2 Strainer**

When using the suction pipe with built-on strainer, this has to be cleaned regularly. How often depends on the amount of coarse particles.



During the initial period, open and inspect once every day to determine the necessary cleaning interval.

**9.2 Once per year**

**9.2.1 Separator**

Replace the O-rings with new ones included in the O-ring service kit. Their positions are shown in the *Spare Parts Catalogue*.

See [9.4.3 Replacement of O-rings in purifier bowl on page 60](#) and [9.4.4 Replacement of O-rings in clarifier bowl on page 62](#) for procedure.

Check the condition of discs in the bowl, replace if necessary.

Fit new vibration dampers.

To get access to the dampers, only remove the three screws and washers shown in illustration 10 on page 64. Inspect the stop flanges of the dampers for possible damage and replace the stop flanges with new ones if necessary. Use Loctite 243 at assembly, see illustration 33 in chapter 9.4.5 Replacement of motor bearings.

## 9.3 Every second year

### 9.3.1 Separator

Check/replace the disc stack to maintain the separation efficiency.









See 9.4.3 Replacement of O-rings in purifier bowl on page 60 and 9.4.4 Replacement of O-rings in clarifier bowl on page 62 for procedure.

## 9.4 Dismantling - assembly instructions for separator

### 9.4.1 Introduction

The illustrations on the following pages describe step by step how to dismantle, clean, replace and assemble the various parts of the separator.

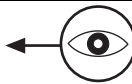
The illustrations have symbols only to indicate the actions required. The key to the symbols is given below.

	Remove		Screw or turn clockwise		Press or move in the direction of arrow		Clean
	Fit, insert		Screw or turn counter-clockwise		Check, make sure		Safety

## 9.4.2 Cleaning of bowl

Comments to illustrations following.

### Illustration 4:

Before dismantling the separator, wait until the rotating parts have come to a complete standstill, which will take up to two minutes.

To be sure, open the front cover and check that the rotation of the electric motor shaft has stopped.

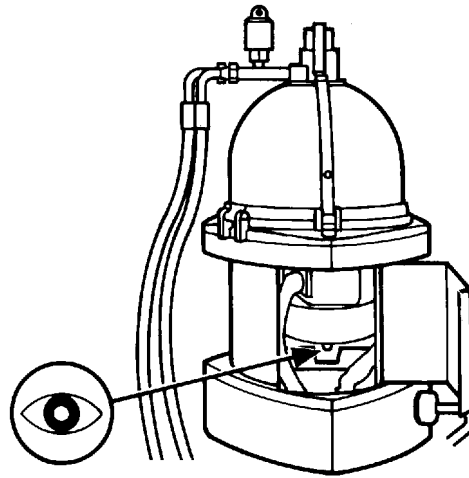

G0908711



### Entrapment hazard

Switch off the power supply, remove the electric cable from the socket and make sure that rotating parts have come to a **complete standstill** before starting any dismantling work.



If the separator is opened too soon, the following could happen:

- The pin on the inside of the connecting housing breaks.
- The pin inside the top of the paring disc breaks.
- Excessive wear of top of level ring.

### Illustration 8:

A few drops of oil will normally leak from the connecting housing when the bowl hood is opened.

If oil continues to leak, the cause could be a non-sealing check valve while the separator is connected to an oil tank with an oil level higher than the separator (siphon effect).

### Illustration 15:



Never use sharp or metallic tools when cleaning the bowl wall. This can damage the coating and later on cause pitting corrosion. Always use soft rags.

Cleaning of the disc stack is not normally necessary unless sludge has accumulated and entered the stack (cleaning interval too long).



Dismantling

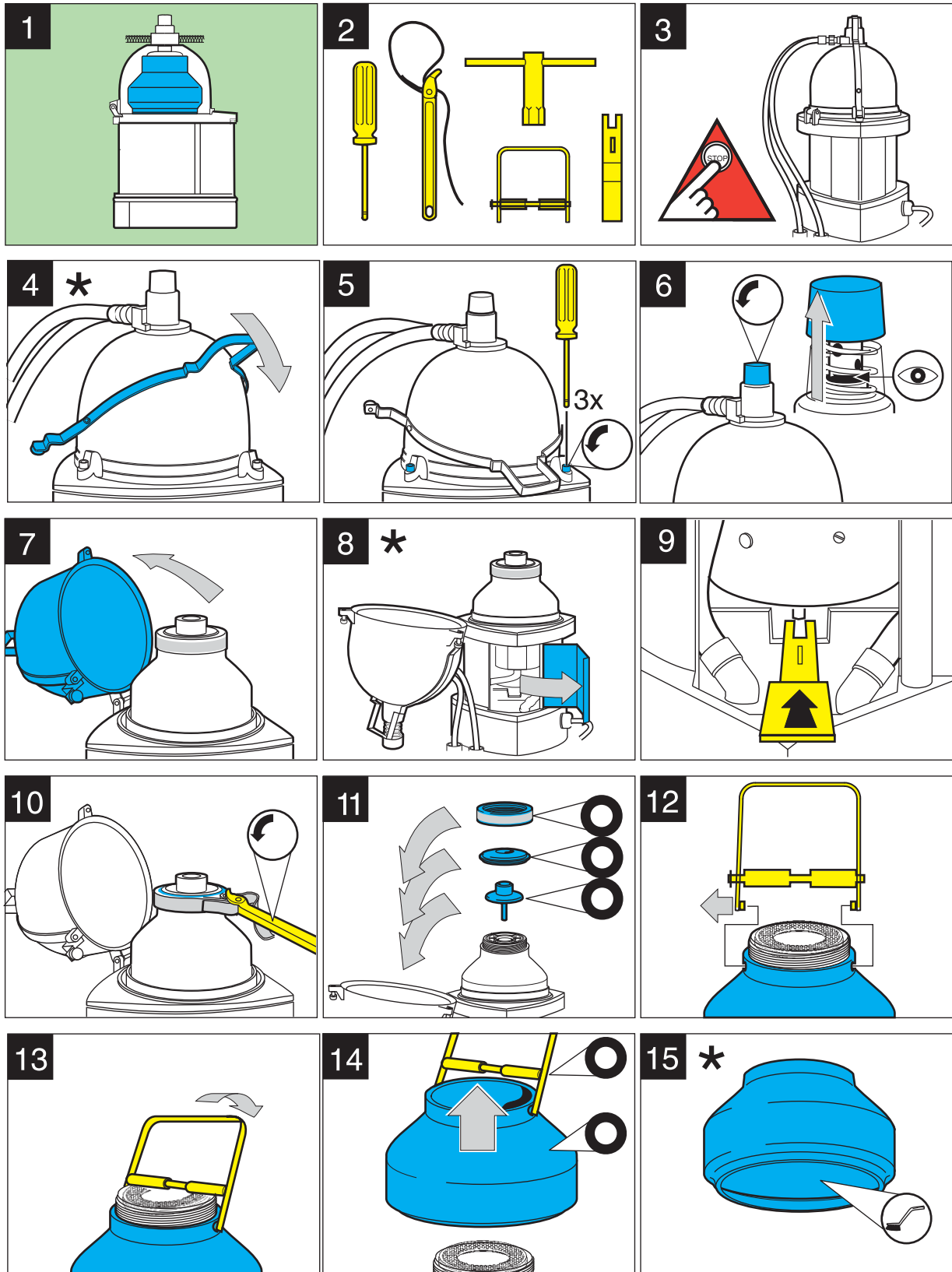

G04491ct

\*See comments on opposite page

**Comments to illustrations on opposite page.**

**Illustration 16:**

When fitting the bowl shell, press firmly downwards with both hands to overcome the resistance from the O-ring fitted on the bowl bottom. A “clicking” sound will be heard.

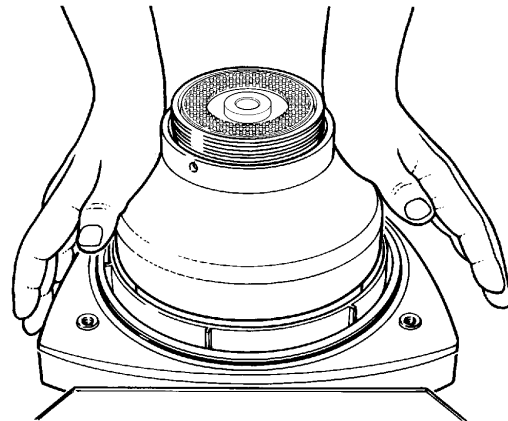

G0912141

**Illustration 17:**

If the level ring (1) and O-ring (2) have been removed, first fit the level ring and then the O-ring outside the level ring. Finally press down the cover (3) firmly with both hands.

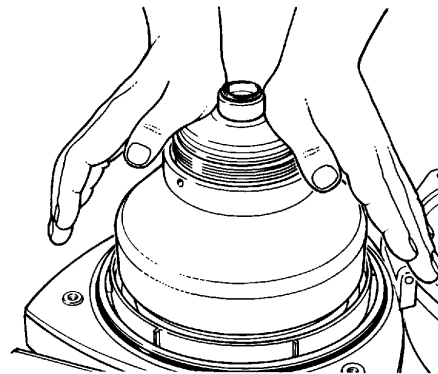

G0912121

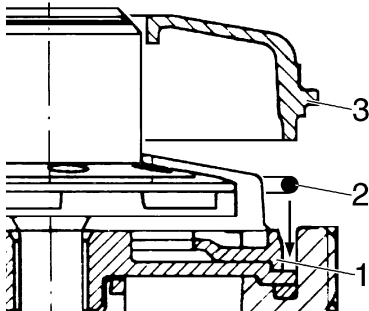

G0907211

**Illustration 18:**

Check that the distance illustrated is max. 0.5 mm. If not, the reason could be:

1. The O-ring outside the level ring is not in the downwards position or the O-ring is located under the level ring.
2. Two washers are fitted under the centre screw fixing the bowl to spindle.

**Illustration 20:**

Only tighten by hand. Never overtighten when assembling parts.

Illustration 22:

**NOTE**

Always screw home the knob fitted on the connecting housing **before** tightening the screws shown in illustration 23. Otherwise there is a risk that the pin inside the connecting housing could break.

**Assembly**

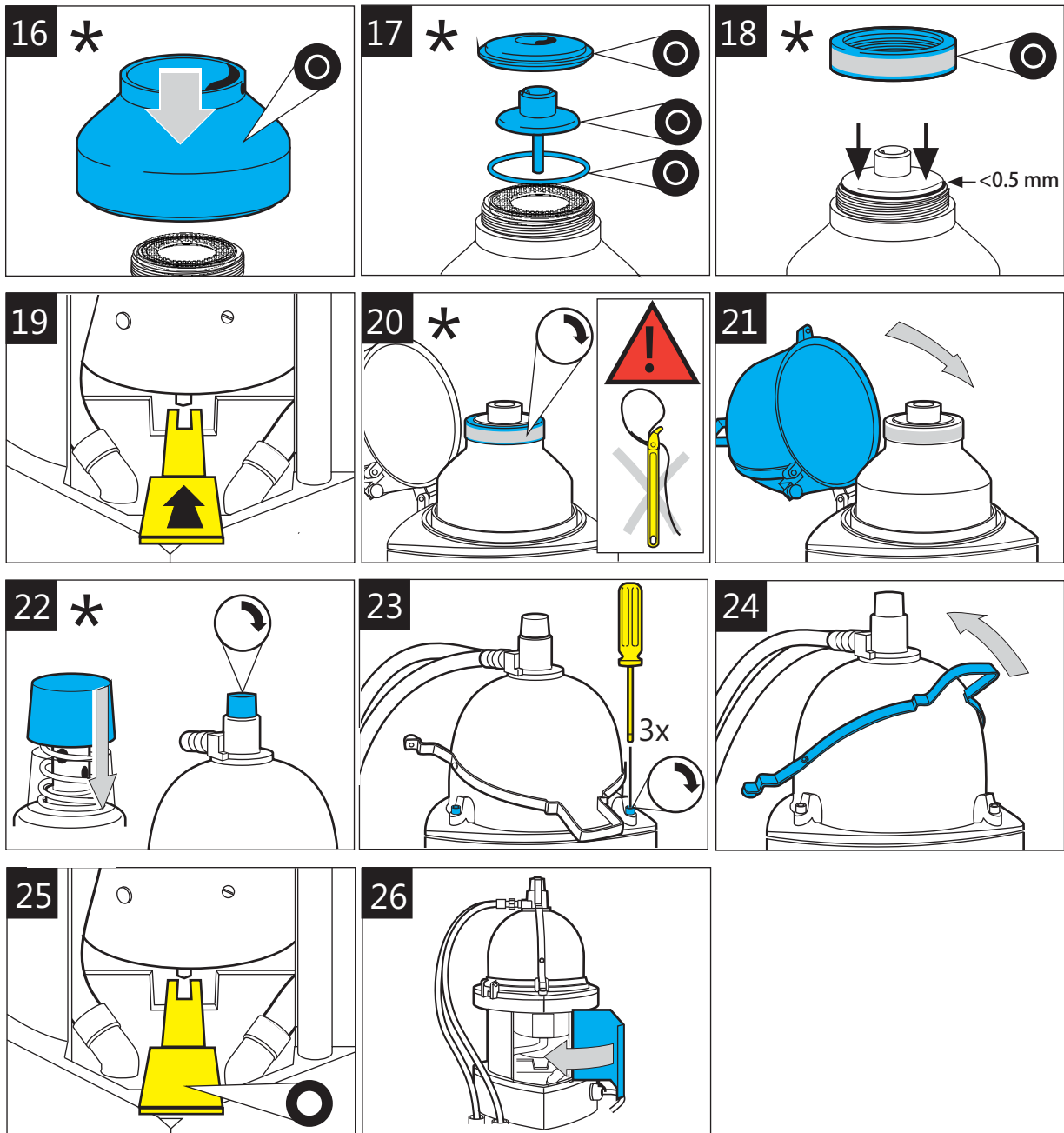

G0449281

\*See comments above and on opposite page.

### 9.4.3 Replacement of O-rings in purifier bowl

Converting from purifier to clarifier bowl or vice versa is described in [5 Working principle of the separator](#).

**Comments to illustrations on opposite page.**

**Illustration 5:**

Take care of the washer.

**Illustration 14:**

Check that the washer is fitted. Otherwise there is a risk that the bowl will not make firm contact with the spindle.

If two or more washers are fitted accidentally this will prevent the top parts of the bowl from being positioned correctly.

**Illustration 15:**



Fit the upper O-ring outside the level ring, see comments to illustration 17.

First dismantle the separator bowl as described in [9.4.2 Cleaning of bowl on page 56](#).

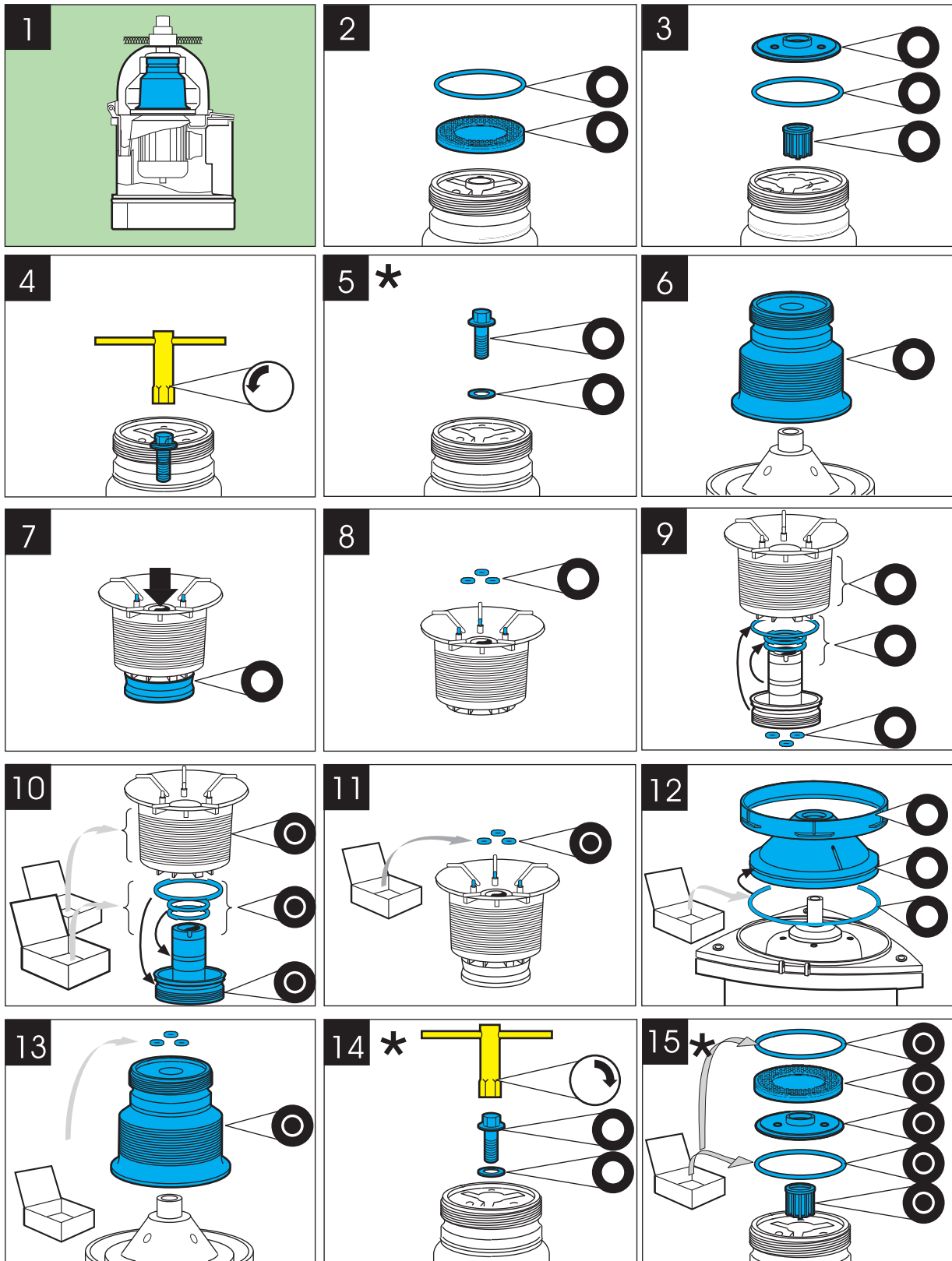

G05191k1

\*See comments on opposite page.

### 9.4.4 Replacement of O-rings in clarifier bowl

Converting from purifier to clarifier bowl or vice versa is described in [5 Working principle of the separator](#).

**Comments to illustrations on opposite page.**

**Illustration 5:**

Take care of the washer.

**Illustration 14:**

Check that the washer is fitted. Otherwise there is a risk that the bowl will not make firm contact with the spindle.

If two or more washers are fitted accidentally this will prevent the top parts of the bowl from being positioned correctly.

**Illustration 15:**



Fit the upper O-ring outside the level ring, see comments to illustration 17 .

First dismantle the separator bowl as described in [9.4.2 Cleaning of bowl on page 56](#).

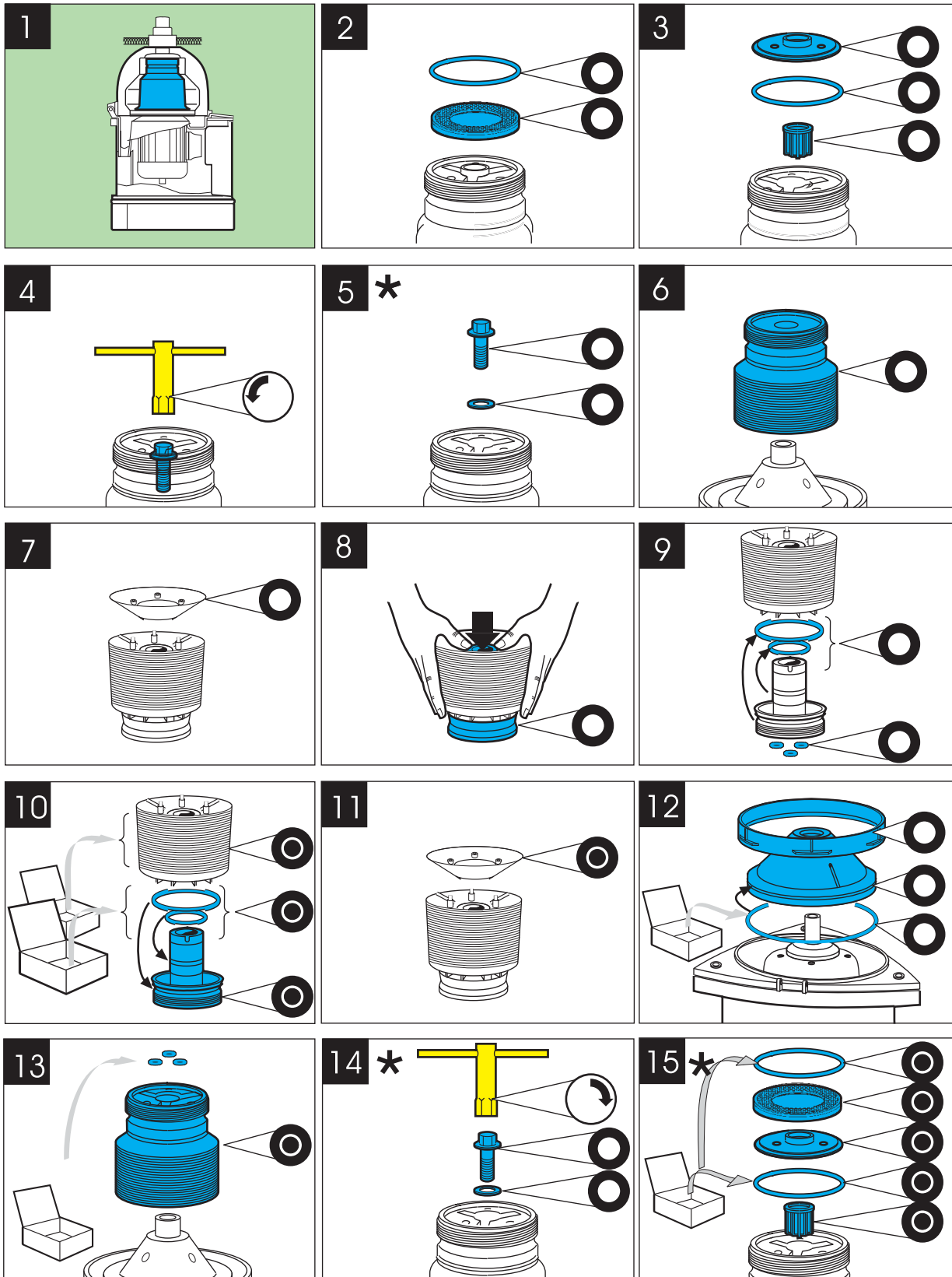

G05191L1

\*See comments on opposite page.

### 9.4.5 Replacement of motor bearings

First dismantle the separator bowl as described in [9.4.2 Cleaning of bowl on page 56](#).

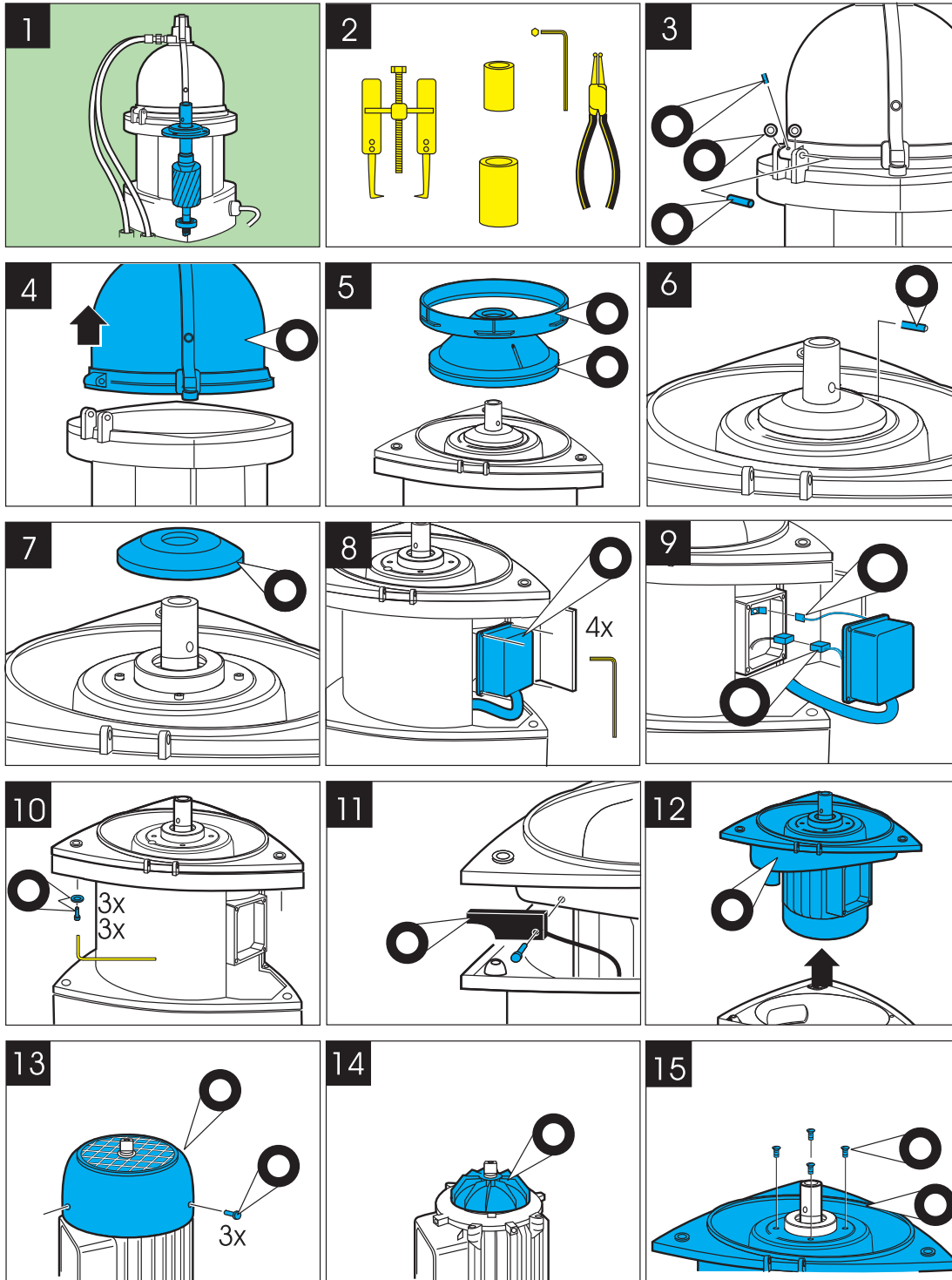

G0449461



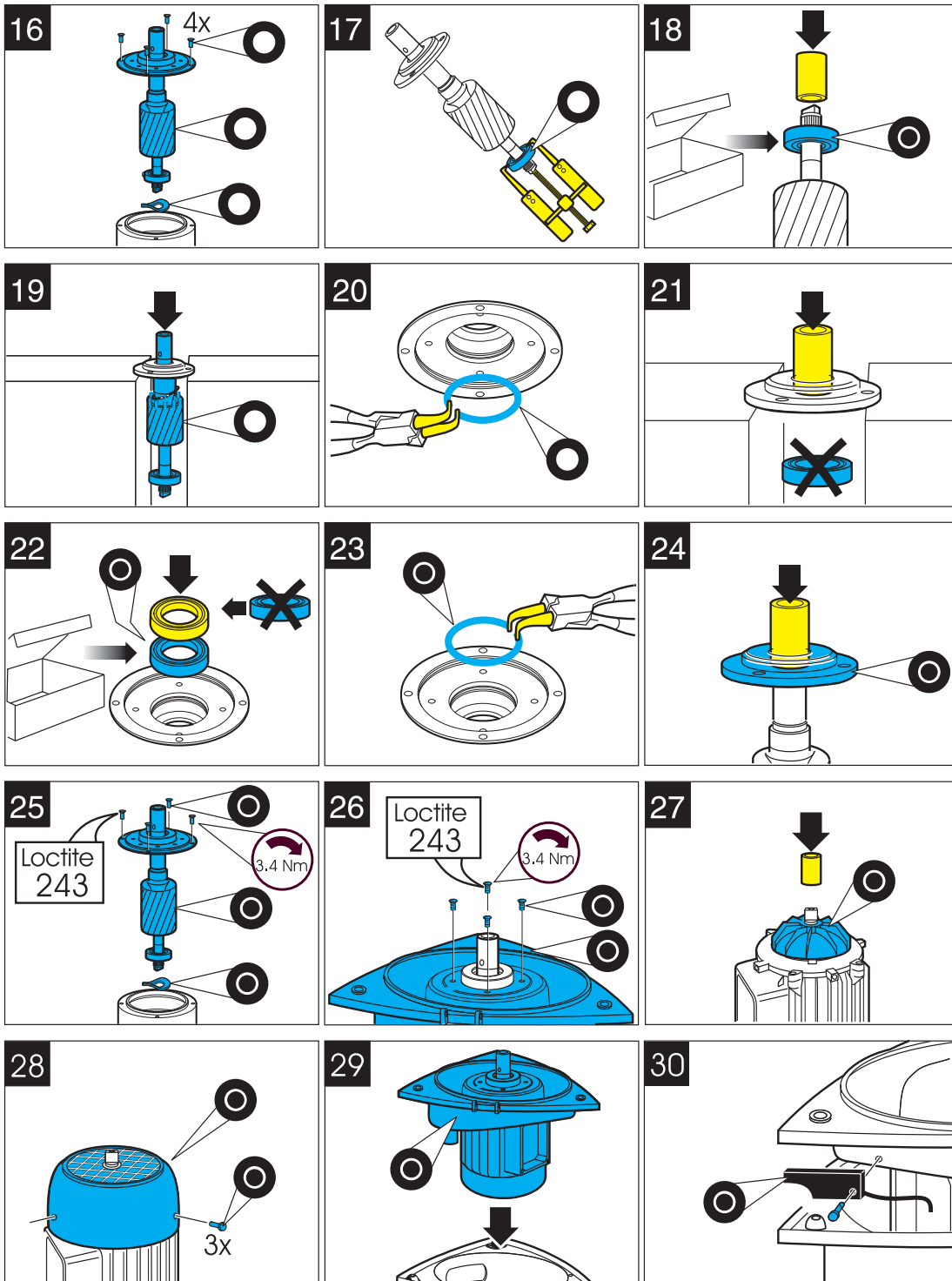

G0449671

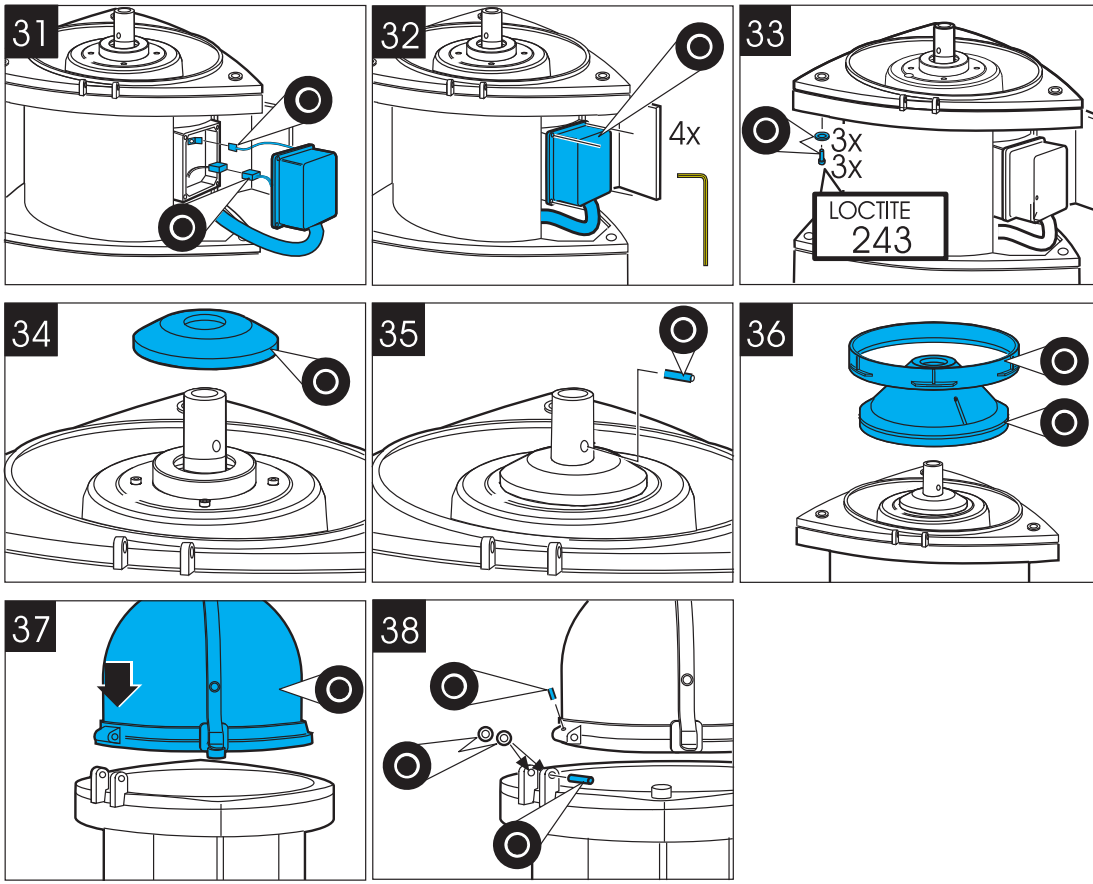

G0449681

---

# 10 Technical data

---

## 10.1 Technical data, system

<b>Type designation:</b>	<i>Alfa Laval Emmie</i> – mobile hydraulic oil cleaning system	
<b>Application:</b>	Use is restricted to removal of solids and water from mineral hydraulic, gear and sterntube lube oils with the following specifications:	
	Process media:	Mineral oil
	Viscosity grade (VG):	15 - 150
	Separation temperature:	+15 – +70 °C
<b>Recommended operating flow:</b>	80 - 120 litres/hour	
<b>Max. ambient temperature:</b>	+45 °C	
<b>Power supply:</b>	230 V (±10%) or 100 - 230 V (±10%), 1 phase, 50/60 Hz	
<b>Amperage:</b>	10 A (230 V), 16 A (100 – 120 V)	
<b>Sound:</b>	Sound power:	Max. 8.9 Bel(A), ISO 3744
	Sound pressure level:	Max. 75 dB(A), ISO 3744
<b>Pressure switch:</b>	Set point for tripping:	50 kPa
<b>Quality requirement of water for liquid seal in bowl (purification):</b>	pH value:	6 – 9
<b>Density feed/sediment, max.:</b>		kg/m <sup>3</sup>
<b>Weight:</b>	60 kg	
<b>Dimensions (L x H x W):</b>	620 x 1140 x 510 mm (24" x 45" x 20")	

## 10.2 Declaration

*Alfa Laval ref. 594945 Rev. 3*

This declaration is issued under the sole responsibility of the manufacturer.

Manufacturer: .....  
 Manufacturer address: .....  
 Separator type: .....  
 Product specification: .....  
 Configuration number: .....  
 Serial number: .....

### EU Declaration of Conformity

The machinery complies with the following Directives:

Designation	Description
2006/42/EC	Machinery Directive
2004/108/EC (to 2016-04-19) 2014/30/EU (from 2016-04-20)	Electromagnetic Compatibility Directive

To meet the requirements the following standards have been applied:

Designation	Description
EN 60204-1	Safety of machinery - Electrical equipment of machines. Part 1: General requirements
EN 61000-6-2	Electromagnetic compatibility (EMC) - Part 6-2: Generic standards - Immunity for industrial environments
EN 61000-6-4	Electromagnetic compatibility (EMC) - Part 6-4: Generic standards - Emission standard for industrial environments
EN ISO 12100	Safety of machinery - General principles for design - Risk assessment and risk reduction
EN ISO 13849-1	Safety of machinery - Safety-related parts of control systems - Part 1: General principles for design
EN ISO 3744	Acoustics - Determination of sound power levels of noise sources using sound pressure

The technical construction file for the machinery is compiled and retained by the authorized person Hans Thomasson within the Product Centre for High Speed Separator systems, Alfa Laval Tumba AB, SE-14780 Tumba Sweden.

Signed for and on behalf of: .....  
 Place: .....  
 Date of issue: .....  
  
 Signature: .....  
 Name: .....  
 Function: .....

---

# 11 Installation

---

## 11.1 Installation alternatives

The **Alfa Laval Emmie** cleaning unit can be connected to a hydraulic oil tank in the three ways described below. The third alternative normally needs no preparations for using the cleaning unit (except maybe removing a cover). However, for the two other alternatives the hydraulic oil tanks must be prepared as described below.

Common recommendations for all three alternatives are:

### NOTE

- Never separate an unfiltered system unless a strainer is fitted in the suction line. When separating an unfiltered system, use the diver tube with fitted strainer as described in 11.1.3 on next page.
- When connecting Alfa Laval Emmie to a hydraulic oil tank as described in 11.1.1 and 11.1.2, it is assumed that the content has been filtered.
- Never connect the return outlet to a pressurized system (which can give too high counter pressure).

### 11.1.1 Replacement of filler cap

The suction and return hoses are connected to the *Alfa Laval Emmie* cap which has replaced the filler cap normally fitted on the tank.

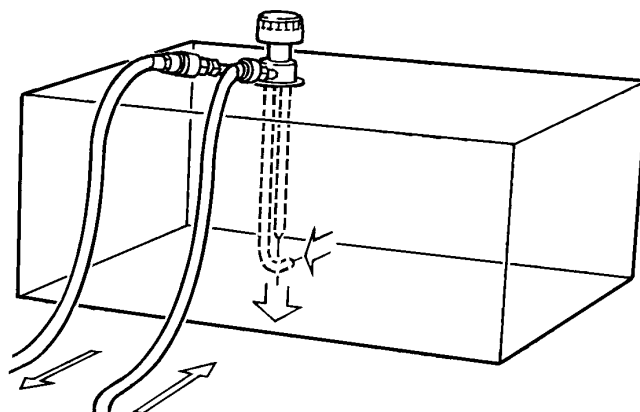

G0912011

### 11.1.2 Connection to drain hole in tank

The suction hose is connected to an outlet fitted into the tank drain hole, while the return hose is connected to a hole on the opposite side of the tank.

A shut-off valve must be connected between the tank and the quickcoupling for the outlet.

Inside the tank the return pipe should be located about 100 mm (A) below the oil surface to prevent aeration of the oil in the tank.

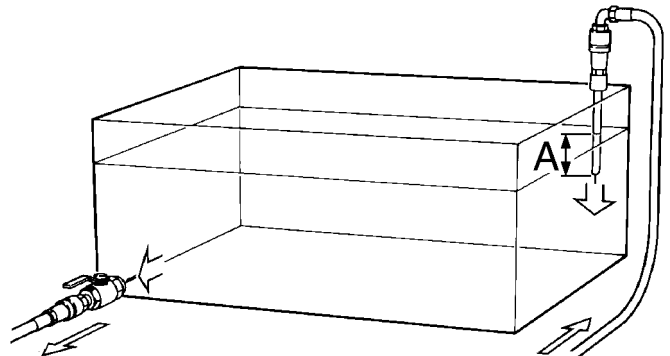

G0912711

### 11.1.3 Using separate suction and return pipes

The suction and return hoses are connected to separate pipes which are inserted into a barrel or similar as shown.

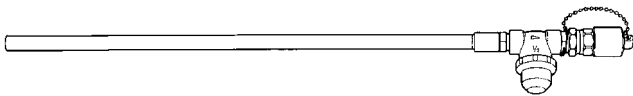

G0912421

*Suction pipe (1/2") with built-on strainer*

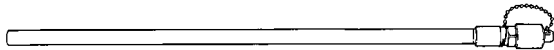

G0912431

*Return pipe (3/8")*

These pipes should preferably also be used when filling a hydraulic oil system with new oil.

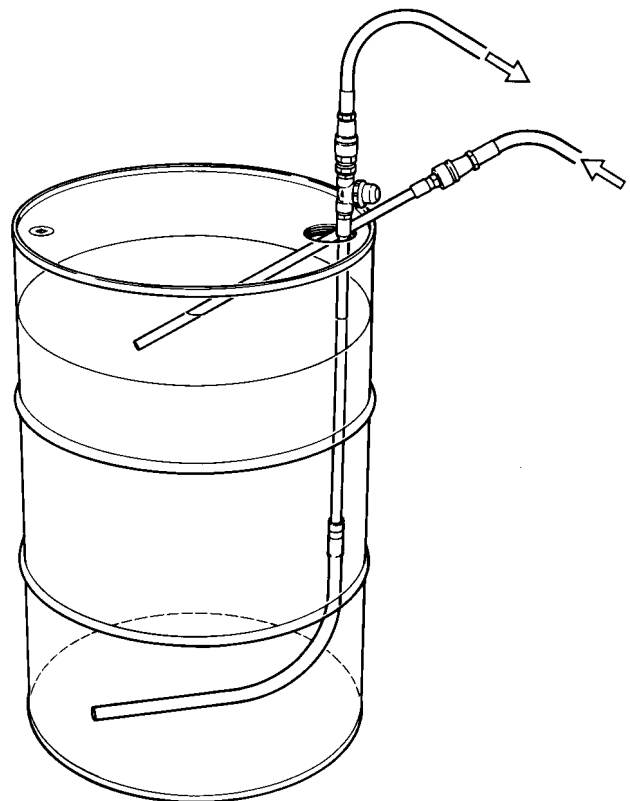

G0912511

# 12 Lifting instruction

## 12.1 Cleaning unit

Attach two lifting straps (1) to the lifting hooks.

The distance between the lifting hooks and crane hook should be min. 1 metre (A).

### NOTE

Weight of unit is approx. 60 kg.

### WARNING

#### Entrapment hazard

Only attach the lifting straps to the two lifting hooks when lifting the cleaning unit.

A falling unit can cause accidents resulting in serious injury to persons and damage to equipment.

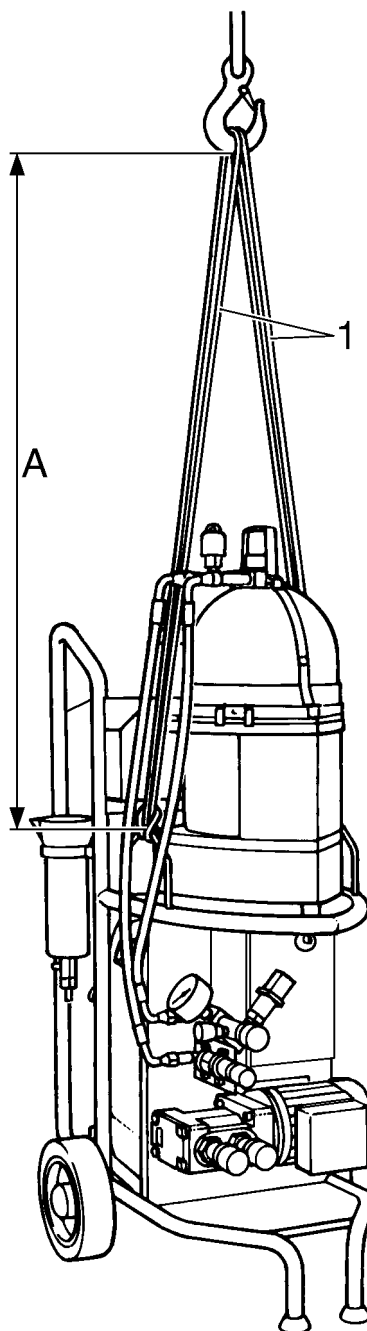

G1105911

*Lifting procedure for cleaning unit*





---

# ***13 Diagrams***

---

## **13.1 Electrical system**

*Alfa Laval ref. 9014733 Rev. 7*



Alfa Laval Tumba AB

Company / customer

Project description

Alfie/Emmie

Main supply

230V AC (100/110/120VAC with optional transformer)

Control voltage

24V DC

Manufacturer (company)

Alfa Laval Tumba AB

Drawing number

9014733

Created on

2014-04-01

SETUTBL

Edit date

2015-10-07

SETUAKL

This document constitutes a contractual obligation on our part only to the extent expressly agreed upon.

This document and its contents are the exclusive property of Alfa Laval AB, and may not be copied, reproduced, transmitted or communicated to a third party, nor used for any purpose without written permission.

Created date 2014-04-01	Created by SETUTBL	Revised by SETUTBL	Project Alfie/Emmie	Title Title page / cover sheet	Location		Page Revision	Revised date 2014-09-05	Page <b>1</b>
Department CAT	Approved date 2015-10-23	Approved by SETUNLN			Mounting		Latest Revision <b>07</b>	Document No. 9014733	Next page 2

This document constitutes a contractual obligation on our part only to the extent expressly agreed upon.

This document and its contents are the exclusive property of Alfa Laval AB, and may not be copied, reproduced, transmitted or communicated to a third party, nor used for any purpose without written permission.

Internal targets

External targets

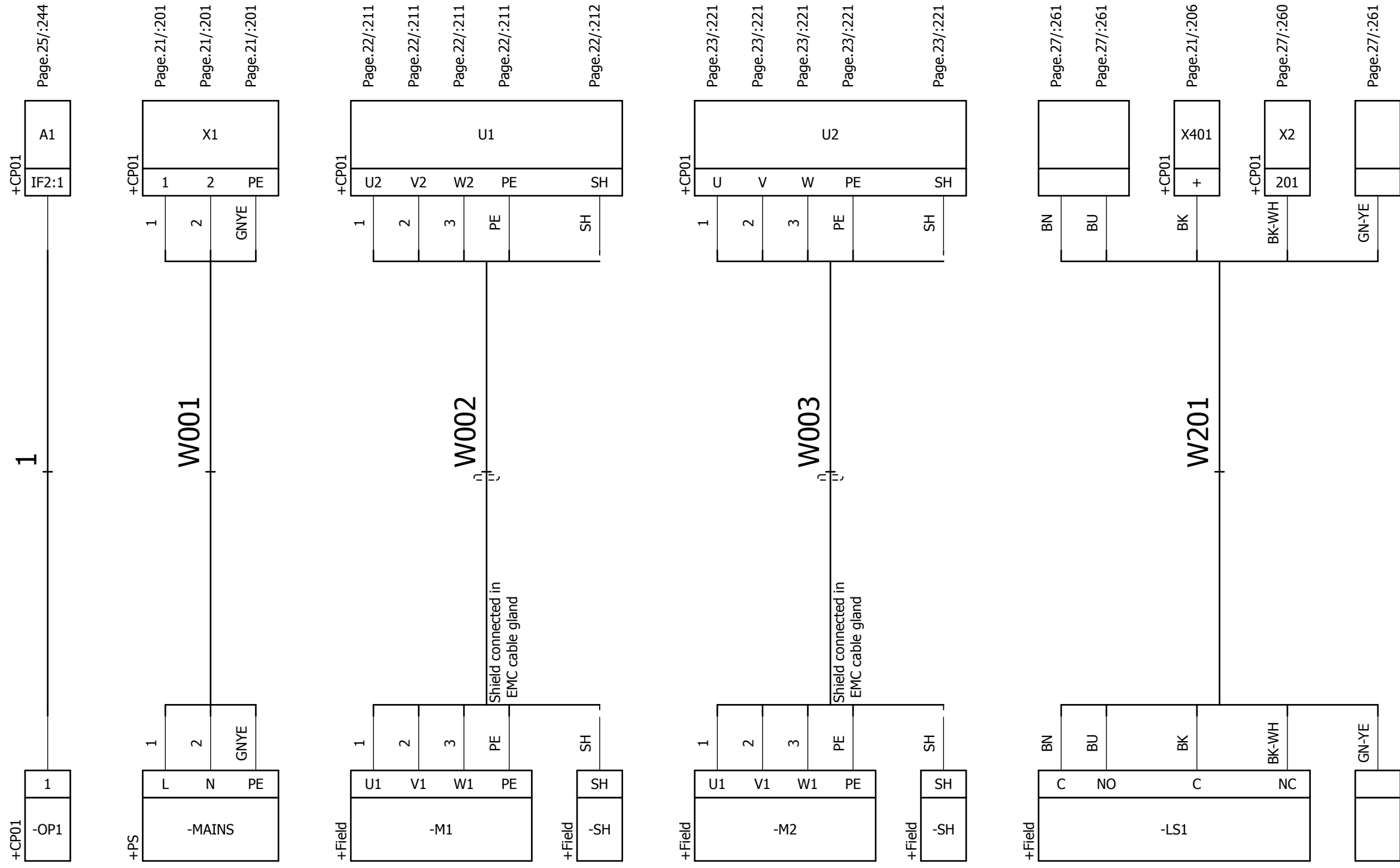

Ethernet to OP

Power Supply:  
1x230V 50/60Hz  
(Max fuse 10A)  
Option:  
1x100/110/120V  
50/60Hz (Max  
fuse 10A)

Separator

Pump

Tank full

Shield SH shall be connected to cable glands, except for power supply cables, they shall be connected to PE bar.

Created date <b>2014-04-01</b>	Created by <b>SETUTBL</b>	Revised by <b>SETUTBL</b>	Project <b>Alfie/Emmie</b>	Title <b>Cable-connection diagram 1 W001 W002 W003 W201</b>	Location		Page Revision <b>06</b>	Revised date <b>2015-03-26</b>	Page <b>2</b>
Department <b>CAT</b>	Approved date <b>2015-10-23</b>	Approved by <b>SETUNLN</b>					Latest Revision <b>07</b>	Document No. <b>9014733</b>	Next page <b>3</b>

This document constitutes a contractual obligation on our part only to the extent expressly agreed upon.

This document and its contents are the exclusive property of Alfa Laval AB, and may not be copied, reproduced, transmitted or communicated to a third party, nor used for any purpose without written permission.

Internal targets

External targets

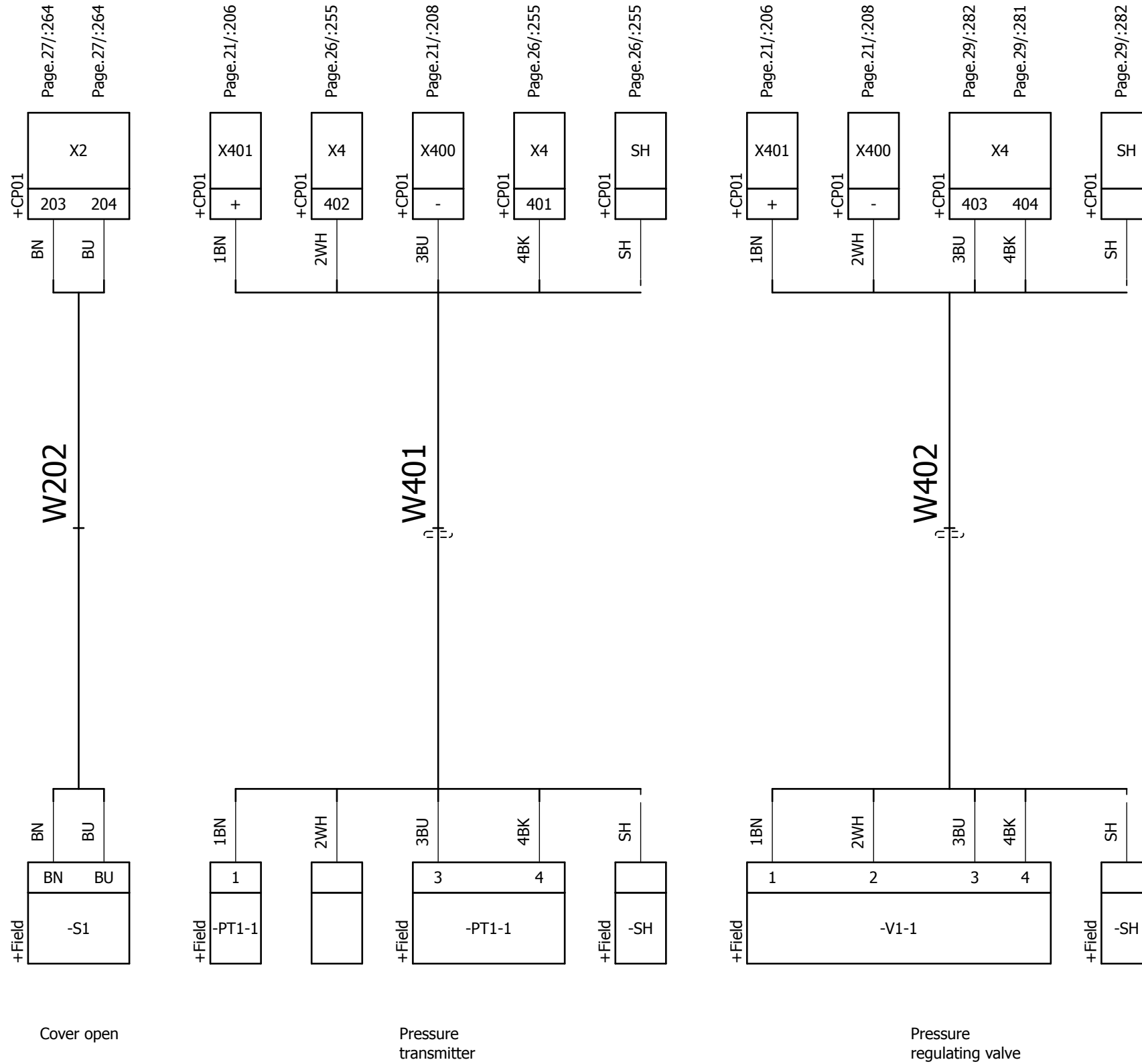

Shield SH shall be connected to cable glands, except for power supply cables, they shall be connected to PE bar.

Created date 2014-04-01	Created by SETUAKL	Revised by SETUAKL	Project Alfie/Emmie	Title Cable-connection diagram W202 W401 W402	Location		Page Revision 07	Revised date 2015-10-07	Page 3
Department CAT	Approved date 2015-10-23	Approved by SETUNLN			Mounting		Latest Revision 07	Document No. 9014733	Next page 4

# Cable overview

Cable no	Source (from)	Target (to)	Cable type	Conductors / Area	Conductors used	Function text	Note
1	=9014733+CP01-A1	=9014733+CP01-OP1	581803 45		1	Ethernet to OP	
W001	=9014733+CP01-X1	=CUSTOMER+PS-MAINS	576705 01	3G1,5	3	Power Supply: 1x230V 50/60Hz (Max fuse 10A) Option: 1x100/110/120V 50/60Hz (Max fuse 10A)	
W002	=9014733+CP01-U1	=9014733+Field-M1	9009089 81	4G1,5	4	Separator	
W003	=9014733+CP01-U2	=9014733+Field-M2	9005079 80	4G1,5	4	Pump	
W201	=9014733+CP01-X2	=9014733+Field-LS1	571937 01	5x0,75	5	Tank full	
W202	=9014733+CP01-X2	=9014733+Field-S1	554151 03	1x2x0,75	2	Cover open	
W401	=9014733+CP01-X401	=9014733+Field-PT1-1	9017476 03	4x0,34	4	Pressure transmitter	
W402	=9014733+CP01-X401	=9014733+Field-V1-1	901747604	4x0,34	4	Pressure regulating valve	

This document constitutes a contractual obligation on our part only to the extent expressly agreed upon.  
 This document and its contents are the exclusive property of Alfa Laval AB, and may not be copied, reproduced, transmitted or communicated to a third party, nor used for any purpose without written permission.

Other equivalent and approved cables may be used.  
 All signal cables should be a Signal Shielded Cable with the shield properly connected to earth as shown in the electrical drawings.

For power cables, armour must be connected to the earth bar.  
 Providing the armour is connected to the earth as shown in the electrical drawings gives sufficient EMC protection.

Note:

- 1) Cable not included in Alfa Laval delivery
- 2) Cable type and size according to VFD/motor specification
- 3) Optional
- 4) If external transformer, main supply is connected to transformer panel

# Wiring Table

Wire Type	N07V-K (or equivalent flame retardent)		
Wire Colour	EN 60204-1:2006 / IEC 60204-1:2005		
Wire Code	IEC 60757		
Power Circuits	0-16A	2,5mm <sup>2</sup>	Black
	16-25A	4mm <sup>2</sup>	Black
	25-32A	6mm <sup>2</sup>	Black
	32-48A	10mm <sup>2</sup>	Black
	48-64A	16mm <sup>2</sup>	Black
	64-85A	25mm <sup>2</sup>	Black
	85-104A	35mm <sup>2</sup>	Black
	104-130A	50mm <sup>2</sup>	Black
Earth (PE)		1,5mm <sup>2</sup>	Yellow / Green
Auxiliary Circuits 24VAC		0,5mm <sup>2</sup>	Red
Auxiliary Circuits 24VDC		0,5mm <sup>2</sup>	Blue
External auxillary Circuits		1mm <sup>2</sup>	Orange

This document constitutes a contractual obligation on our part only to the extent expressly agreed upon.

This document and its contents are the exclusive property of Alfa Laval AB, and may not be copied, reproduced, transmitted or communicated to a third party, nor used for any purpose without written permission.

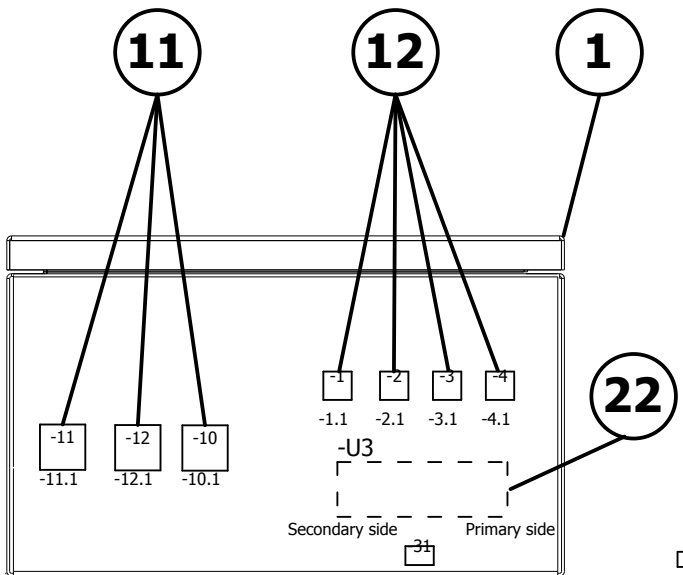

### Technical data

IP54  
 SSAISI304 Stainless steel 1.5mm thickness  
 EMC-doorsealing  
 Cable tray: ABB T20 part No. E2998812 or equivalent

### Instructions

Rectifier -G1 must be mounted like shown to maintain maximum derating.  
 Use silicone when mounting transformer to maintain IP54.  
 Line filter -U3 must be mounted with primary side to the right hand side and secondary side to the left hand side

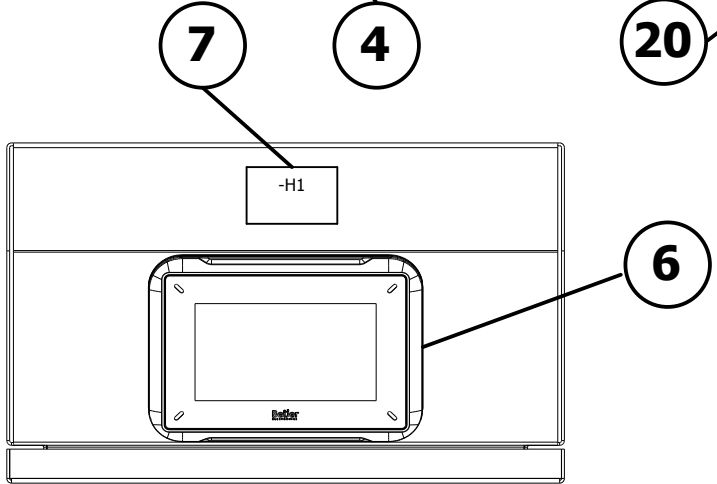
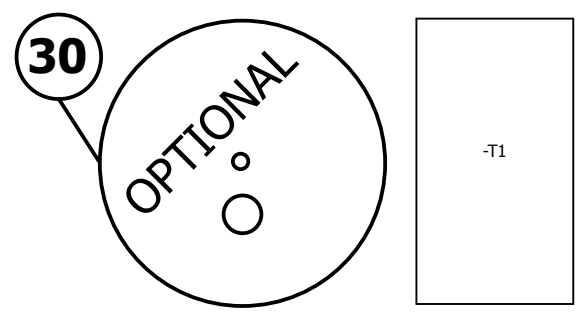
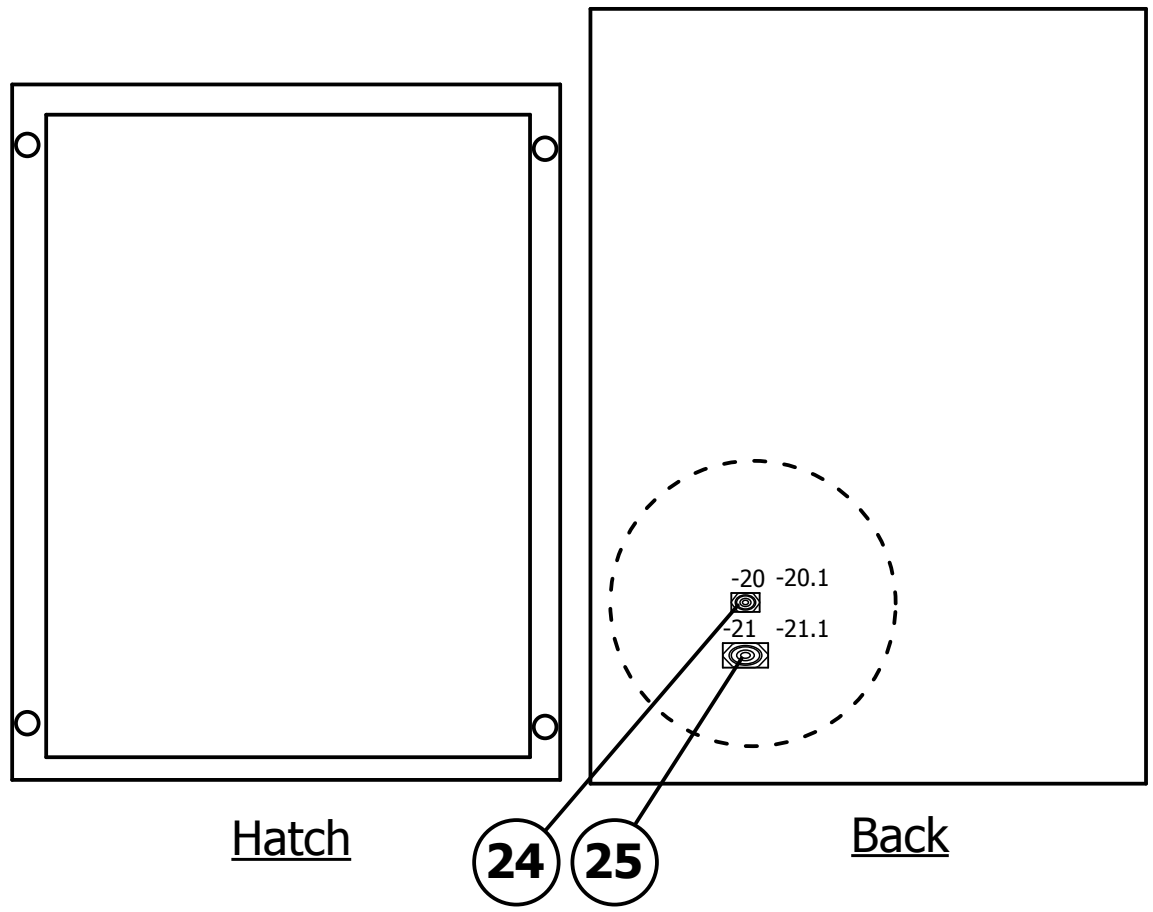
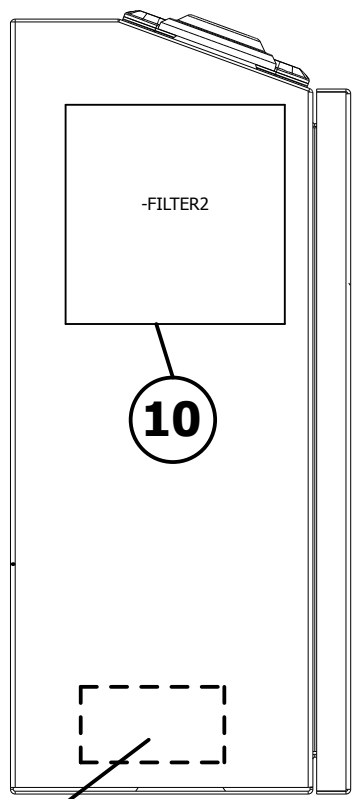
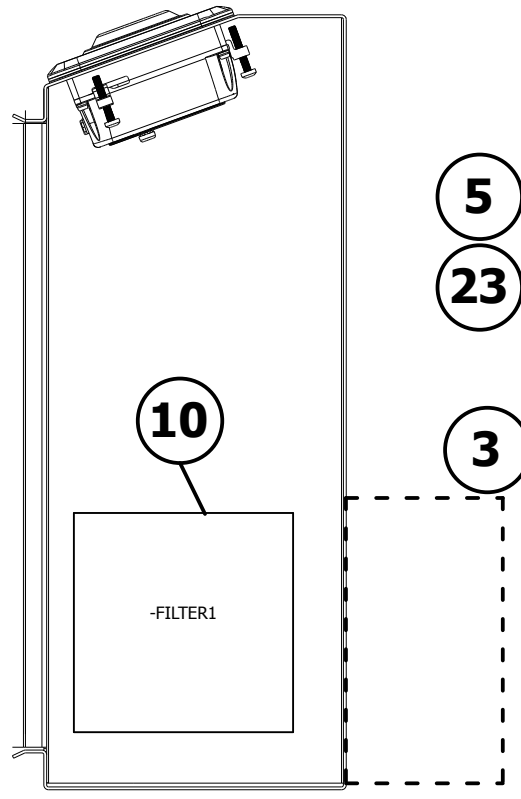
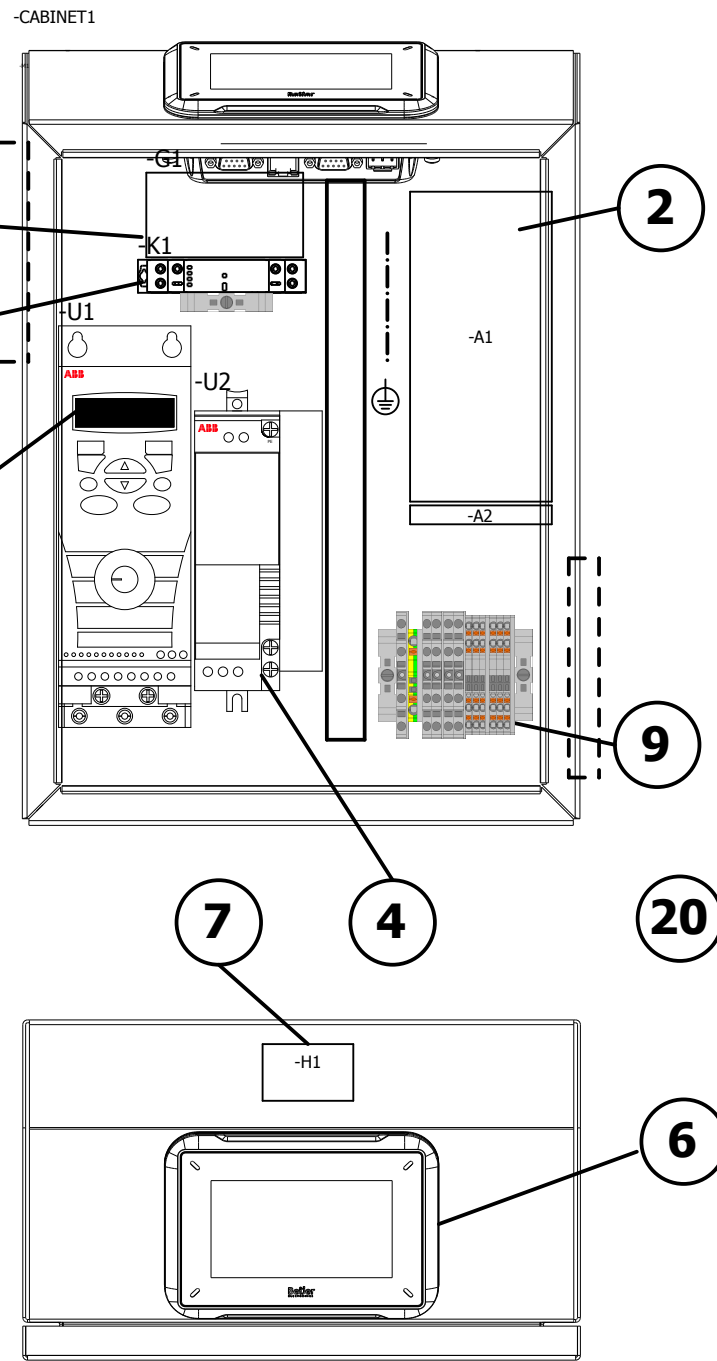

This document constitutes a contractual obligation on our part only to the extent expressly agreed upon.

Created date 2014-04-01	Created by SETUTBL	Revised by SETUAKL	Project Alfie/Emmie	Title Control cabinet assembly	Location =9014733		Page Revision 07	Revised date 2015-10-23	Page 11
Department CAT	Approved date 2015-10-23	Approved by SETUNLN			Mounting +CP01		Latest Revision 07	Document No. 9014733	Next page 12

Ø12	Ø16	Ø20
1	4	4

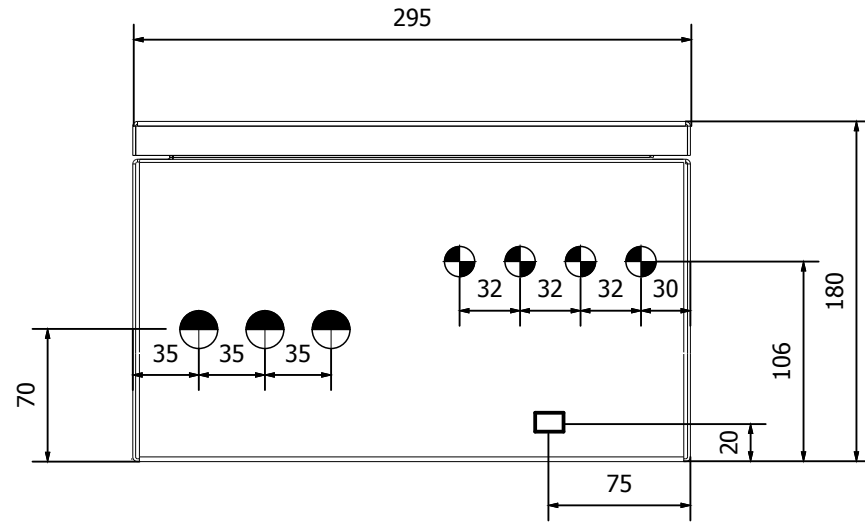

**Mounting rail**

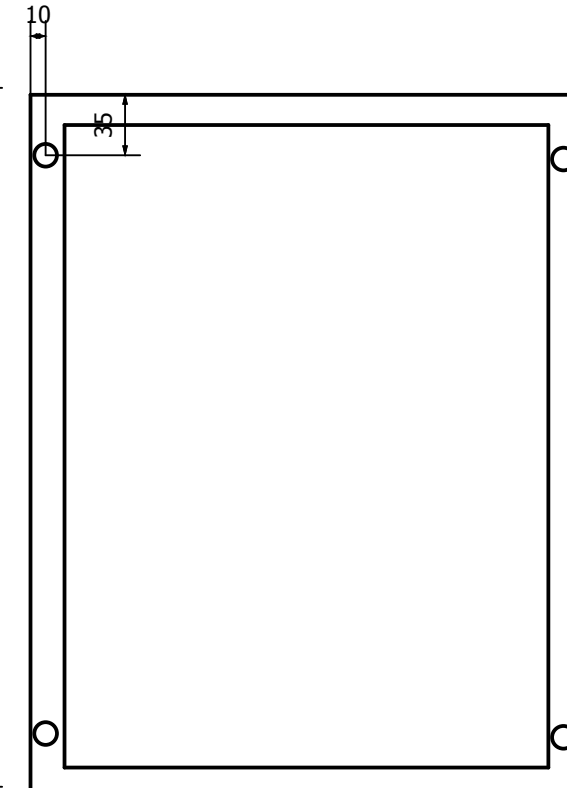
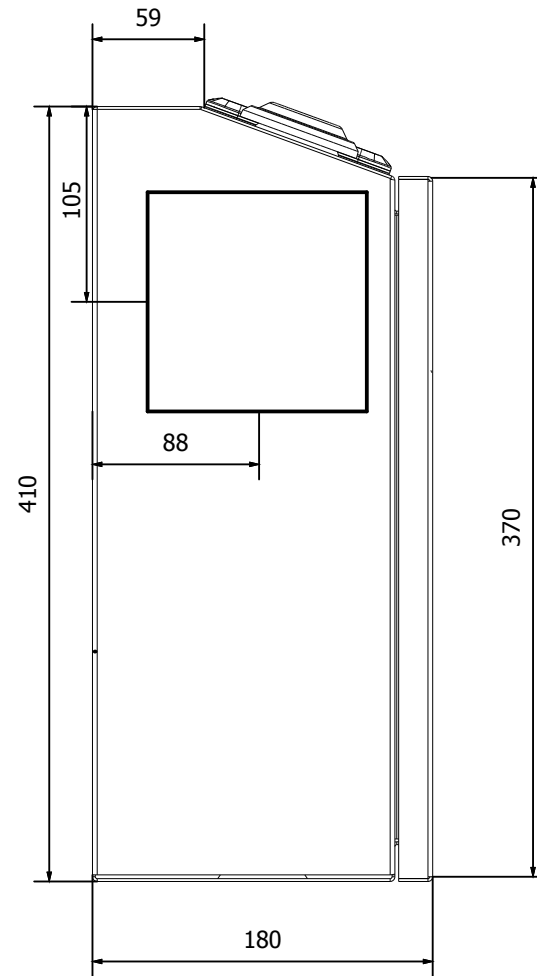
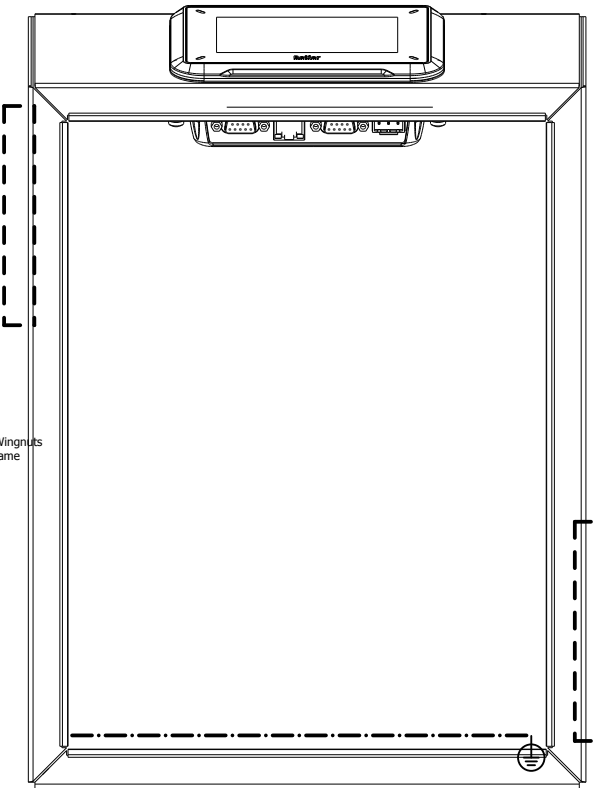
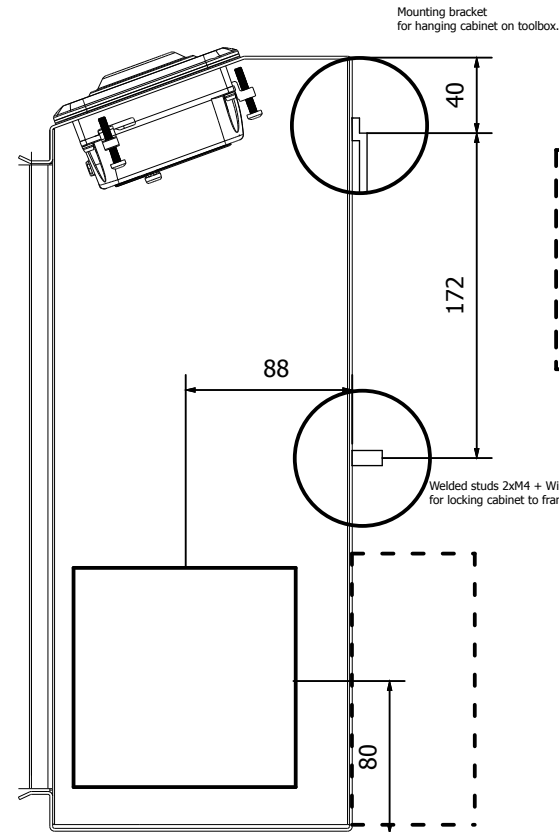
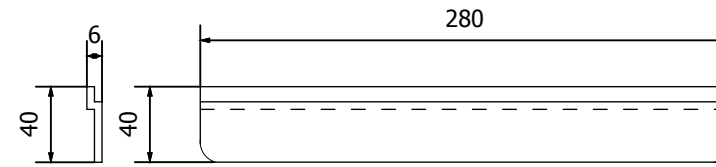

**Hatch**

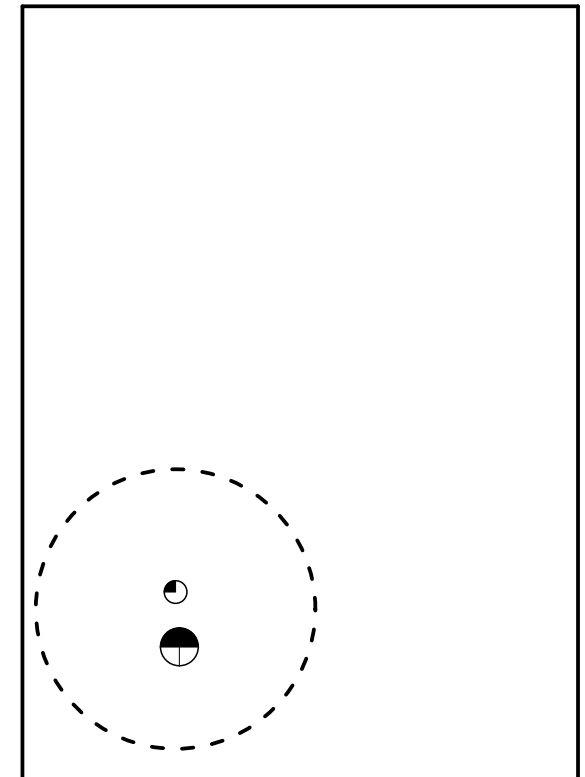

**Back**

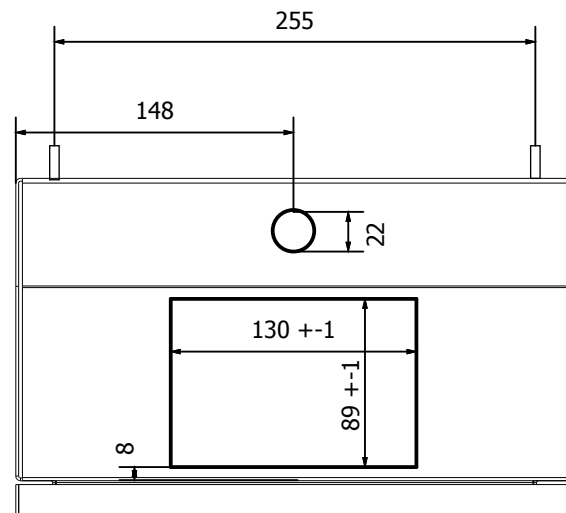
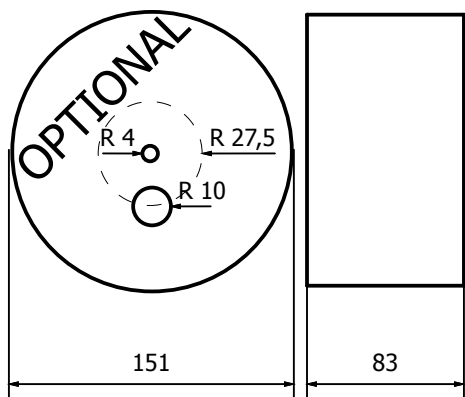

All measurements in mm

This document constitutes a contractual obligation on our part only to the extent expressly agreed upon.

This document and its contents are the exclusive property of Alfa Laval AB, and may not be copied, reproduced, transmitted or communicated to a third party, nor used for any purpose without written permission.

Created date 2014-04-01	Created by SETUTBL	Revised by SETUAKL	Project Alfie/Emmie	Title Control cabinet assembly	Location =9014733		Page Revision 07	Revised date 2015-10-23	Page 12
Department CAT	Approved date 2015-10-23	Approved by SETUNLN			Mounting +CP01		Latest Revision 07	Document No. 9014733	Next page 13



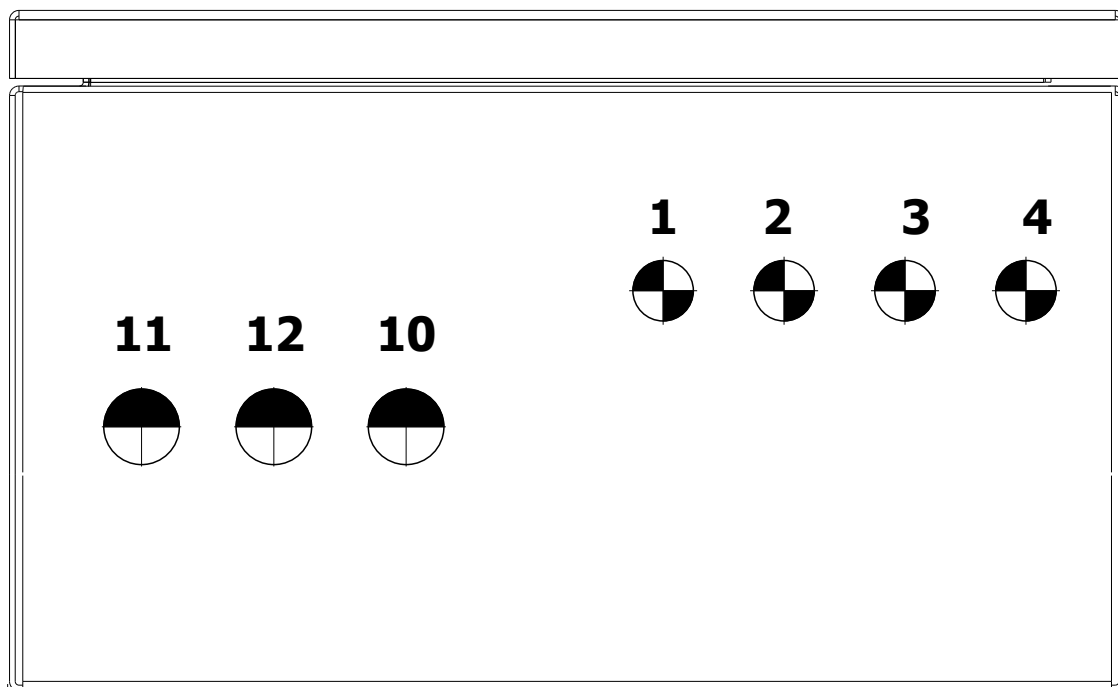

Cable glands		
No	Size	Cable
1	16	W201
2	16	W202
3	16	W401
4	16	W402
10	20	W001
11	20	W002
12	20	W003

Ø16	Ø20
4	6

This document constitutes a contractual obligation on our part only to the extent expressly agreed upon.

This document and its contents are the exclusive property of Alfa Laval AB, and may not be copied, reproduced, transmitted or communicated to a third party, nor used for any purpose without written permission.

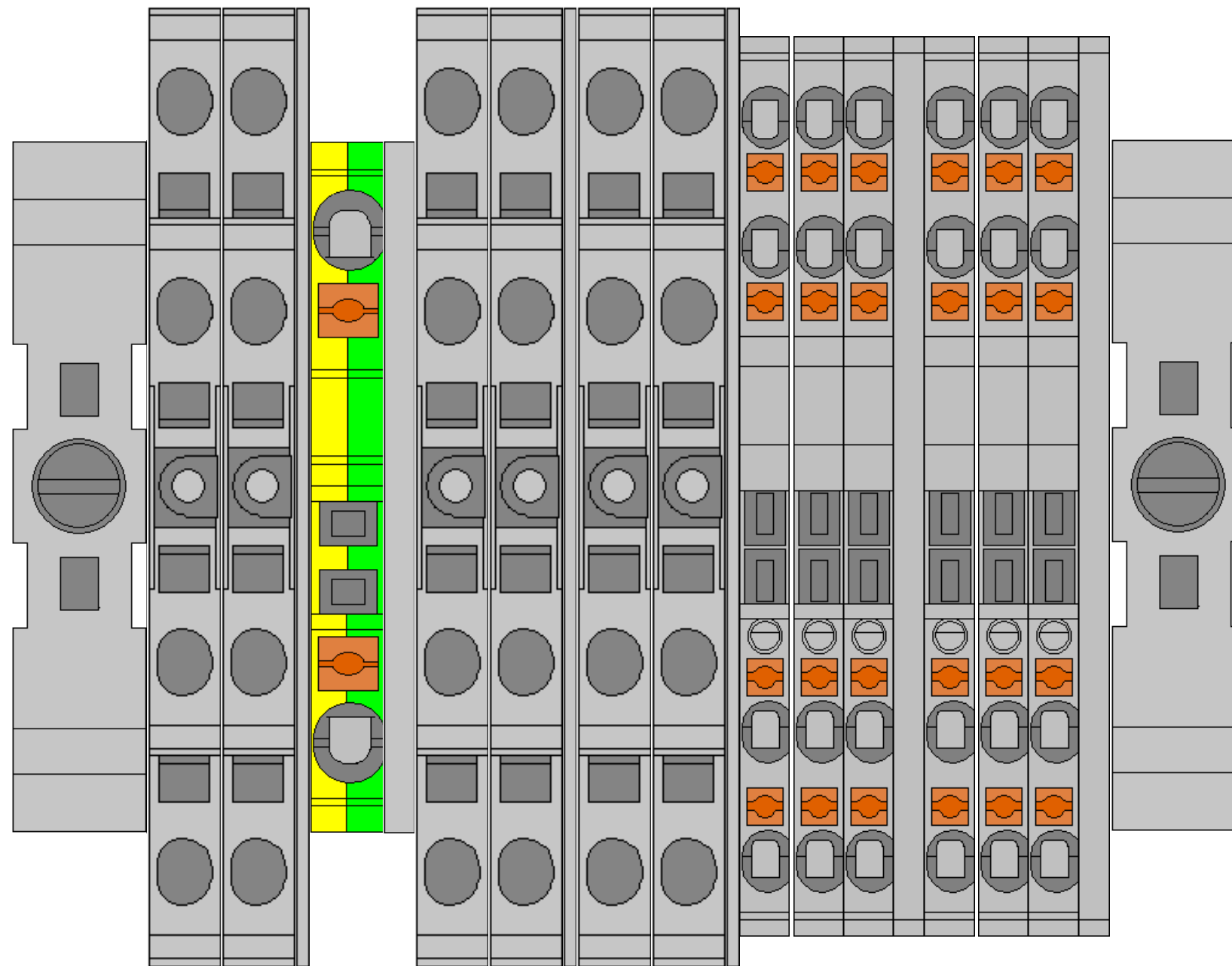

**X1**

**X2**

**X4**

**X400**

**X401**

This document constitutes a contractual obligation on our part only to the extent expressly agreed upon.

This document and its contents are the exclusive property of Alfa Laval AB, and may not be copied, reproduced, transmitted or communicated to a third party, nor used for any purpose without written permission.

Created date 2014-04-01	Created by SETUTBL	Revised by SETUTBL	Project Alfie/Emmie	Title Terminal assembly	Location =9014733		Page Revision 06	Revised date 2015-03-26	Page <b>14</b>
Department CAT	Approved date 2015-10-23	Approved by SETUNLN			Mounting +CP01		Latest Revision <b>07</b>	Document No. 9014733	Next page 15

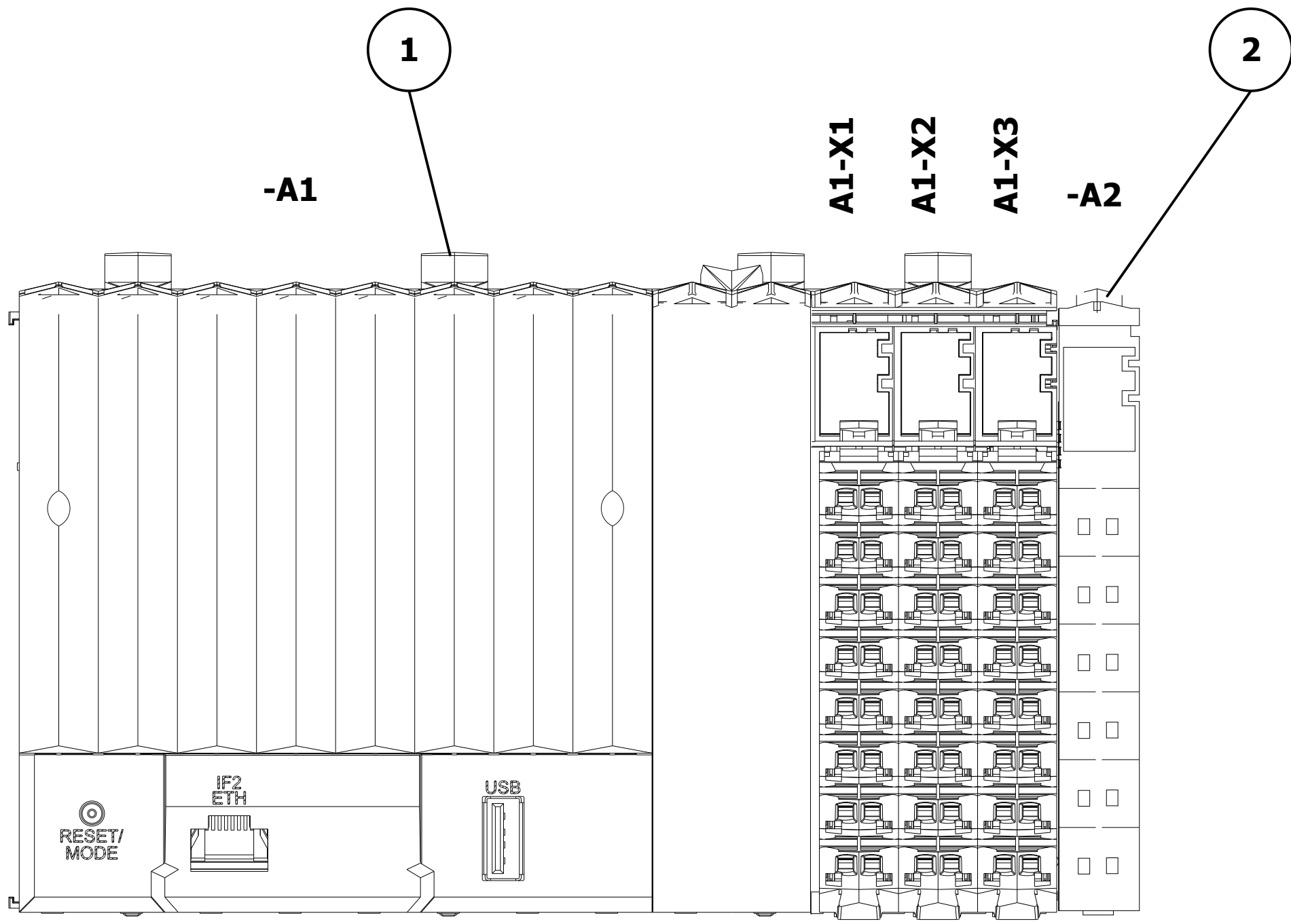

Note : A1-X1 to A1-X3 are integrated on CPU.

This document constitutes a contractual obligation on our part only to the extent expressly agreed upon.

This document and its contents are the exclusive property of Alfa Laval AB, and may not be copied, reproduced, transmitted or communicated to a third party, nor used for any purpose without written permission.

Created date 2014-04-01	Created by SETUTBL	Revised by SETUTBL	Project Alfie/Emmie	Title PLC Assembly	Location =9014733		Page Revision 05	Revised date 2015-01-14	Page 15
Department CAT	Approved date 2015-10-23	Approved by SETUNLN			Mounting +CP01		Latest Revision 07	Document No. 9014733	Next page 21

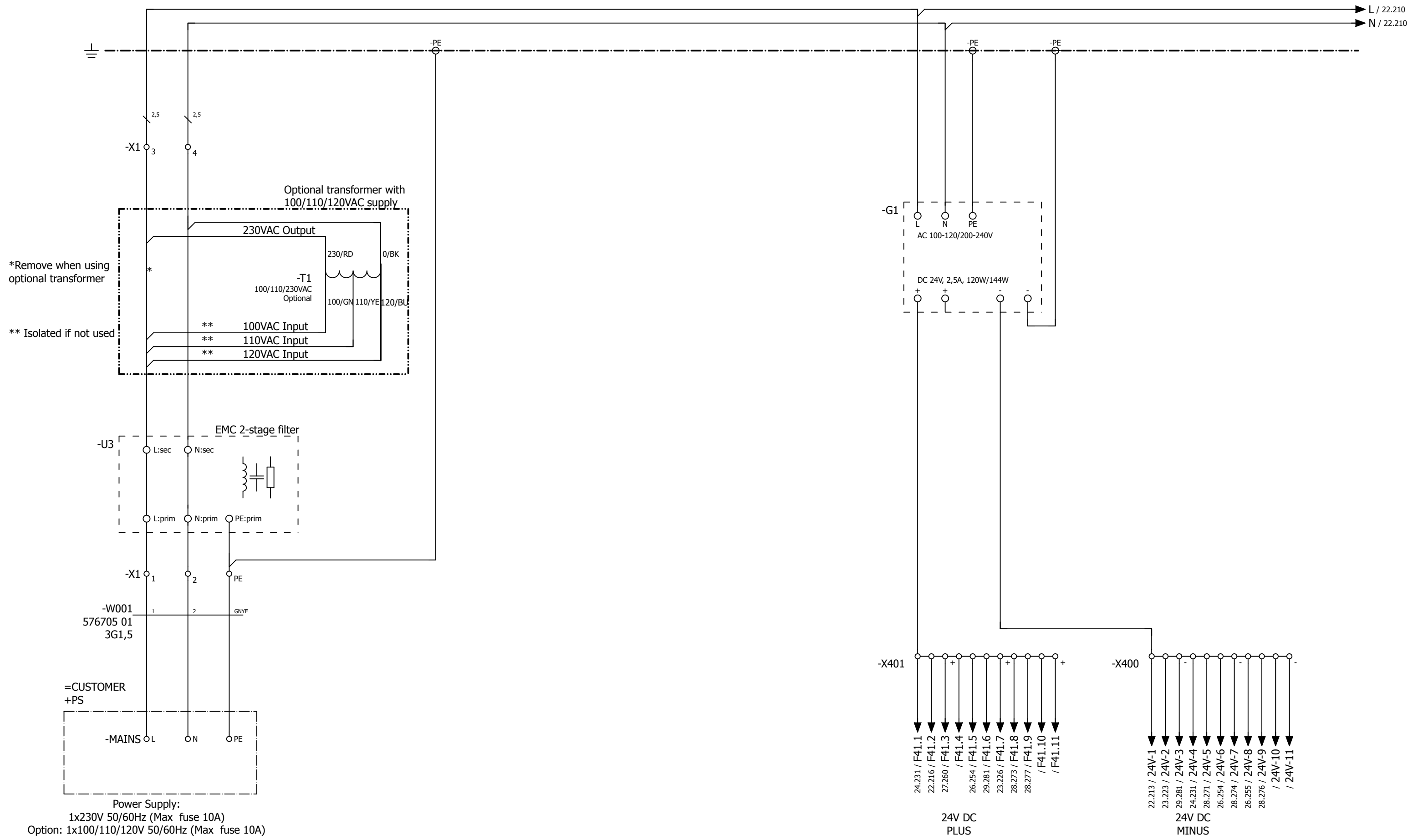

This document constitutes a contractual obligation on our part only to the extent expressly agreed upon.

This document and its contents are the exclusive property of Alfa Laval AB, and may not be copied, reproduced, transmitted or communicated to a third party, nor used for any purpose without written permission.

Created date <b>2014-04-01</b>	Created by <b>SETUTBL</b>	Revised by <b>SETUAKL</b>	Project <b>Alfie/Emmie</b>	Title <b>230VAC 24VDC</b>	Location <b>=9014733</b>		Page Revision <b>07</b>	Revised date <b>2015-10-23</b>	Page <b>21</b>
Department <b>CAT</b>	Approved date <b>2015-10-23</b>	Approved by <b>SETUNLN</b>					Latest Revision <b>07</b>	Document No. <b>9014733</b>	Next page <b>22</b>

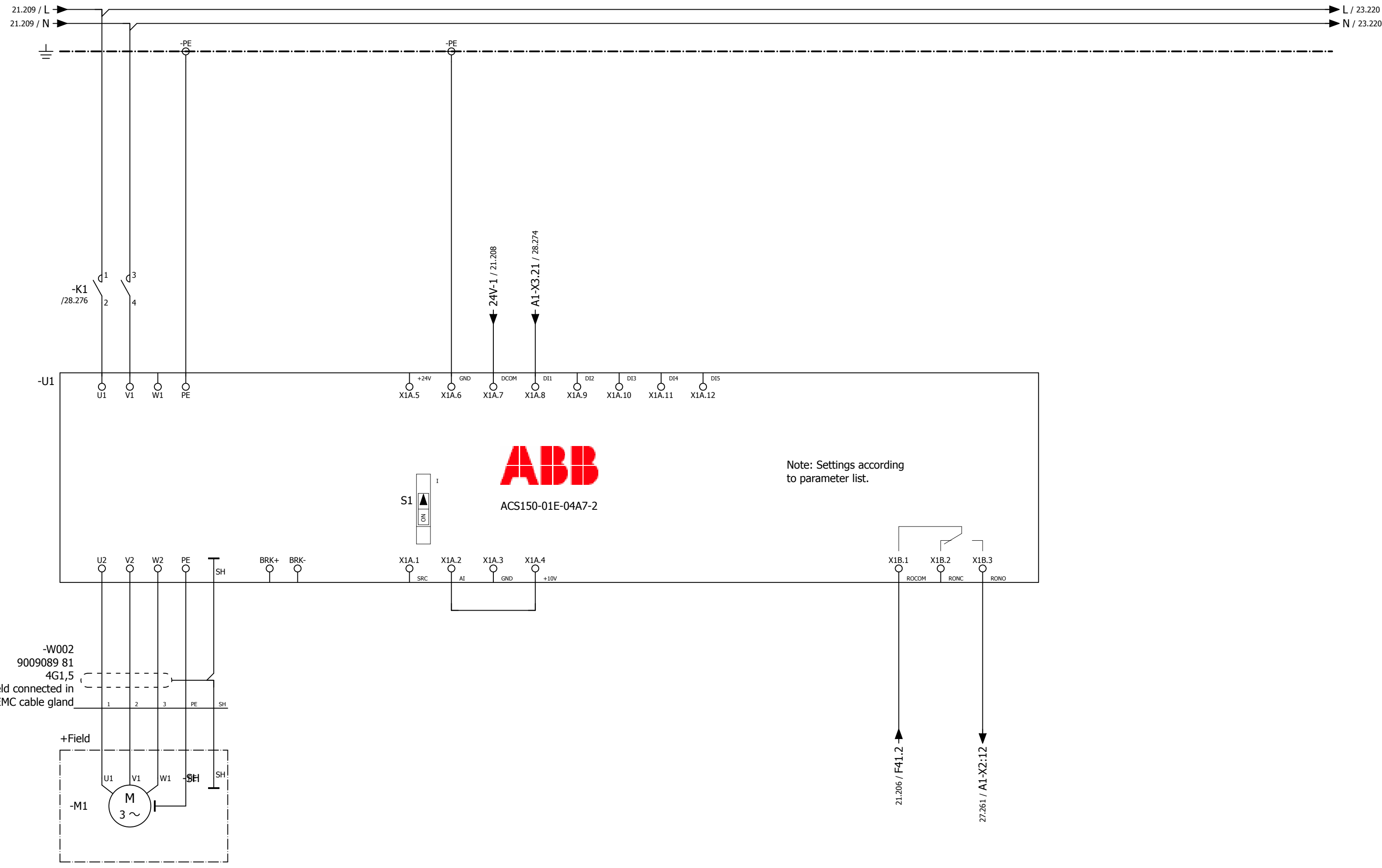

Separator

This document constitutes a contractual obligation on our part only to the extent expressly agreed upon.

This document and its contents are the exclusive property of Alfa Laval AB, and may not be copied, reproduced, transmitted or communicated to a third party, nor used for any purpose without written permission.

Created date <b>2014-04-01</b>	Created by <b>SETUTBL</b>	Revised by <b>SETUTBL</b>	Project <b>Alfie/Emmie</b>	Title <b>Separator</b>	Location <b>=9014733</b>		Page Revision <b>05</b>	Revised date <b>2015-01-13</b>	Page <b>22</b>
Department <b>CAT</b>	Approved date <b>2015-10-23</b>	Approved by <b>SETUNLN</b>			Mounting <b>+CP01</b>		Latest Revision <b>07</b>	Document No. <b>9014733</b>	Next page <b>23</b>

This document constitutes a contractual obligation on our part only to the extent expressly agreed upon.

This document and its contents are the exclusive property of Alfa Laval AB, and may not be copied, reproduced, transmitted or communicated to a third party, nor used for any purpose without written permission.

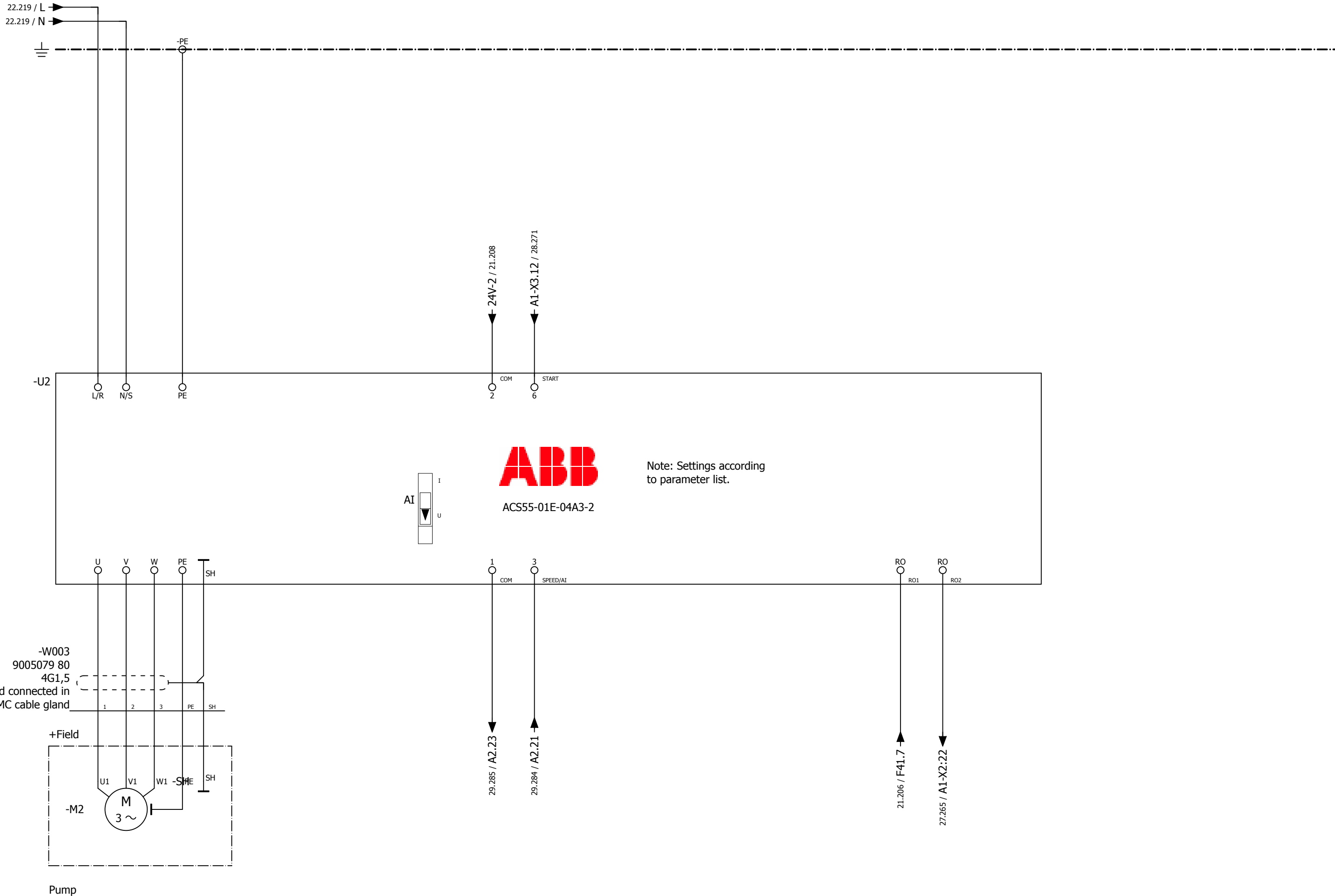

Created date 2014-04-01	Created by SETUTBL	Revised by SETUTBL	Project Alfie/Emmie	Title Pump	Location =9014733		Page Revision 04	Revised date 2014-12-01	Page 23
Department CAT	Approved date 2015-10-23	Approved by SETUNLN			Mounting +CP01		Latest Revision 07	Document No. 9014733	Next page 24



\* Jumpered in ferrule

HMI Cabinet

Ethernet to OP

This document constitutes a contractual obligation on our part only to the extent expressly agreed upon.

This document and its contents are the exclusive property of Alfa Laval AB, and may not be copied, reproduced, transmitted or communicated to a third party, nor used for any purpose without written permission.

Created date <b>2014-04-01</b>	Created by <b>SETUTBL</b>	Revised by <b>SETUTBL</b>	Project <b>Alfie/Emmie</b>	Title <b>HMI Panels</b>	Location <b>=9014733</b>		Page Revision <b>06</b>	Revised date <b>2015-03-24</b>	Page <b>24</b>
Department <b>CAT</b>	Approved date <b>2015-10-23</b>	Approved by <b>SETUNLN</b>			Mounting <b>+CP01</b>		Latest Revision <b>07</b>	Document No. <b>9014733</b>	Next page <b>25</b>

This document constitutes a contractual obligation on our part only to the extent expressly agreed upon.

This document and its contents are the exclusive property of Alfa Laval AB, and may not be copied, reproduced, transmitted or communicated to a third party, nor used for any purpose without written permission.

-A1

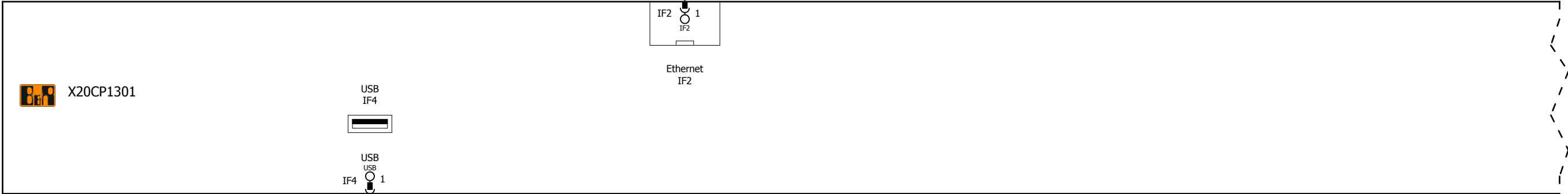

Created date 2014-04-01	Created by SETUTBL	Revised by SETUTBL	Project Alfie/Emmie	Title A1 - CPU	Location =9014733		Page Revision 02	Revised date 2014-09-05	Page 25
Department CAT	Approved date 2015-10-23	Approved by SETUNLN			Mounting +CP01		Latest Revision 07	Document No. 9014733	Next page 26



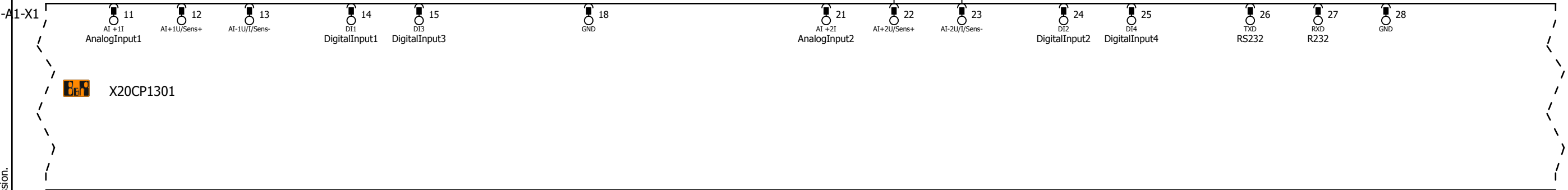
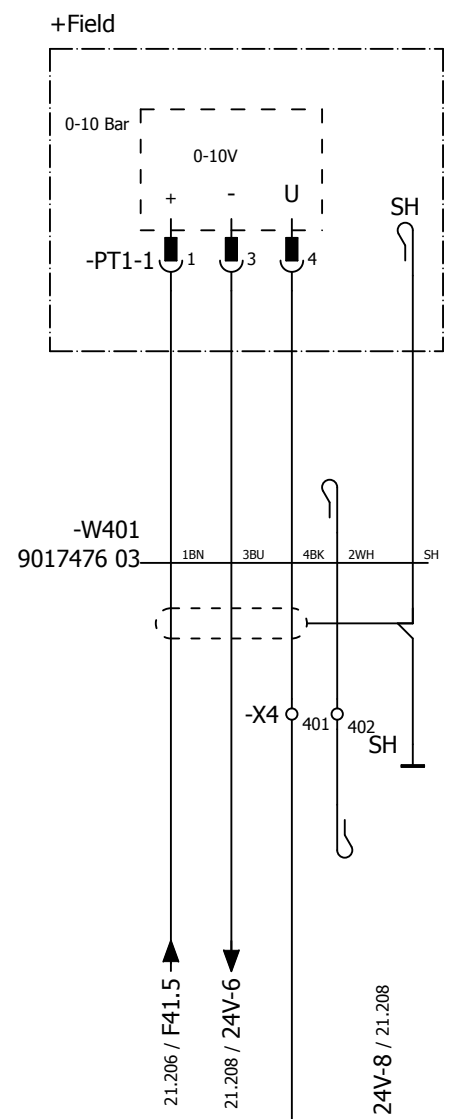

Pressure transmitter

This document constitutes a contractual obligation on our part only to the extent expressly agreed upon.

Created date 2014-04-01	Created by SETUTBL	Revised by SETUTBL	Project Alfie/Emmie	Title X1 - Inputs	Location =9014733		Page Revision 06	Revised date 2015-03-26	Page 26
Department CAT	Approved date 2015-10-23	Approved by SETUNLN			Mounting +CP01		Latest Revision 07	Document No. 9014733	Next page 27

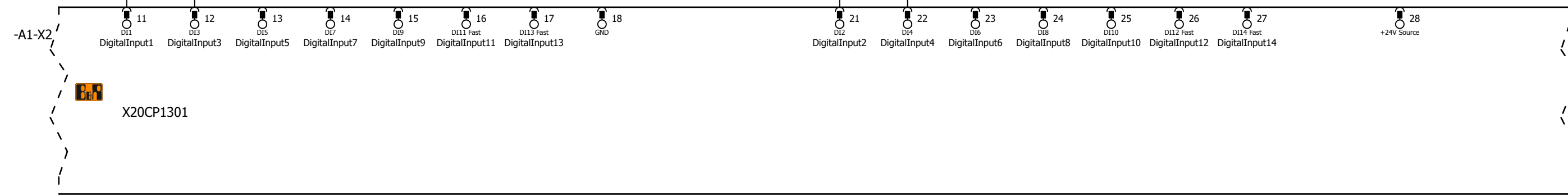
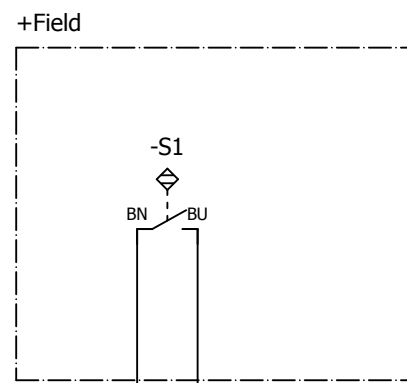
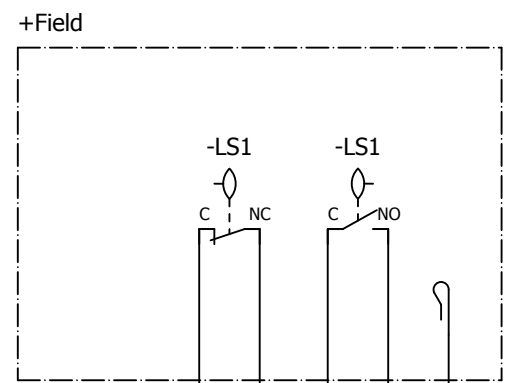

Tank full

Separator Fault

Cover open

Pump Fault

This document constitutes a contractual obligation on our part only to the extent expressly agreed upon.

This document and its contents are the exclusive property of Alfa Laval AB, and may not be copied, reproduced, transmitted or communicated to a third party, nor used for any purpose without written permission.

Created date 2014-04-01	Created by SETUTBL	Revised by SETUTBL	Project Alfie/Emmie	Title X2 - Inputs	Location =9014733		Page Revision 06	Revised date 2015-03-26	Page 27
Department CAT	Approved date 2015-10-23	Approved by SETUNLN			Mounting +CP01		Latest Revision 07	Document No. 9014733	Next page 28

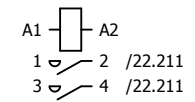
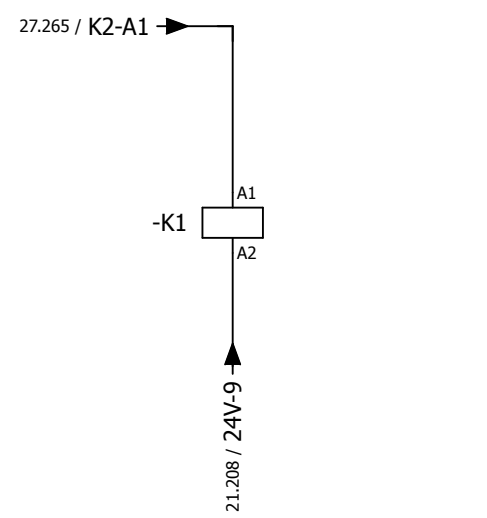
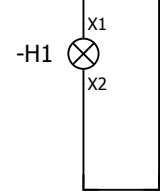
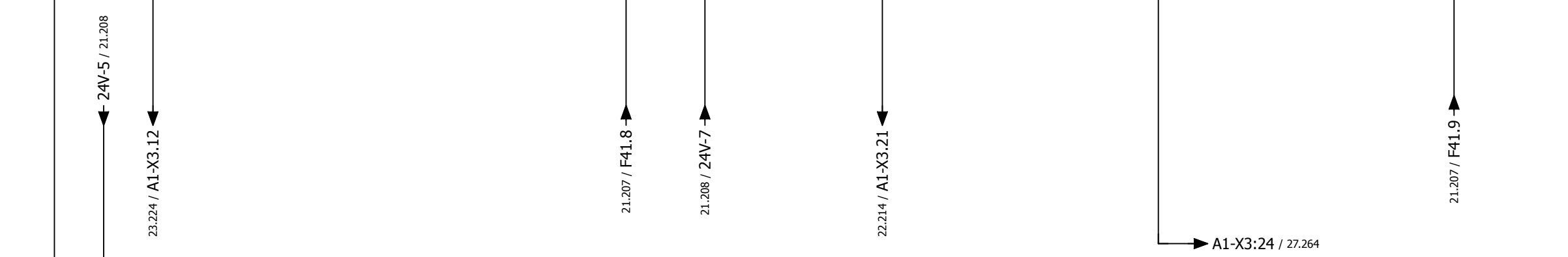
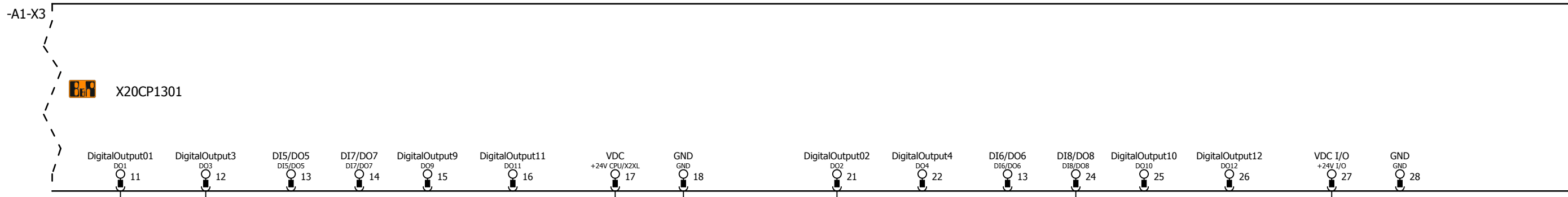

Indication  
Common  
Alarm

Pump  
start

Separator  
start

External Alarm  
ON=NO ALARM

Enable VFD  
separator

Note!  
24VDC Max 0.5A

This document constitutes a contractual obligation on our part only to the extent expressly agreed upon.

Created date 2014-04-01	Created by SETUTBL	Revised by SETUTBL	Project Alfie/Emmie	Title X3 - Outputs	Location =9014733		Page Revision 06	Revised date 2015-03-24	Page 28
Department CAT	Approved date 2015-10-23	Approved by SETUNLN			Mounting +CP01		Latest Revision 07	Document No. 9014733	Next page 29

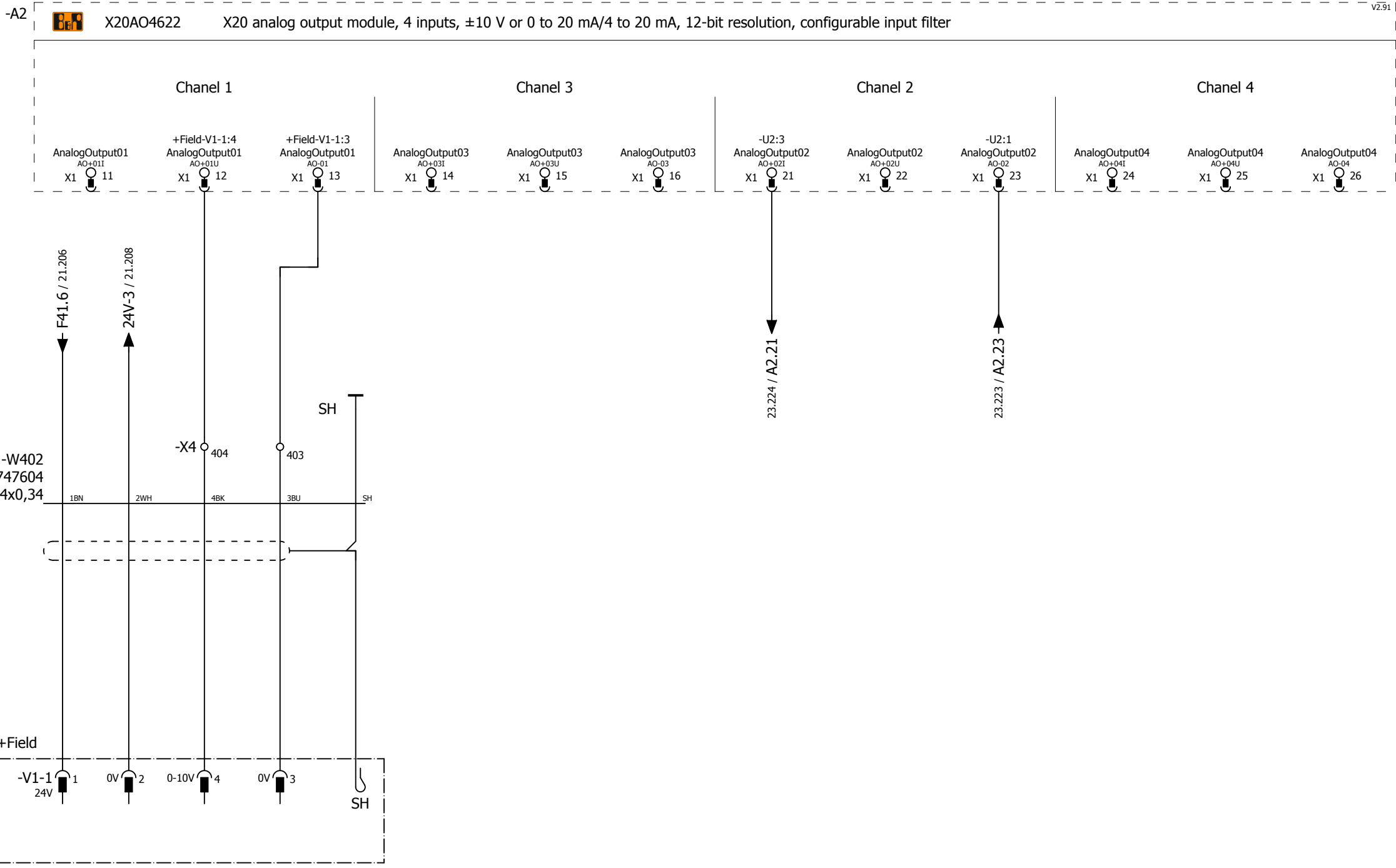

Pressure regulating valve

Pump VFD speed

This document constitutes a contractual obligation on our part only to the extent expressly agreed upon.

This document and its contents are the exclusive property of Alfa Laval AB, and may not be copied, reproduced, transmitted or communicated to a third party, nor used for any purpose without written permission.

Created date 2014-04-01	Created by SETUTBL	Revised by SETUTBL	Project Alfie/Emmie	Title A2 - Analog outputs	Location =9014733		Page Revision 06	Revised date 2015-03-26	Page 29
Department CAT	Approved date 2015-10-23	Approved by SETUNLN			Mounting +CP01		Latest Revision 07	Document No. 9014733	Next page