

This document and its contents is owned by Alfa Laval AB (publ) or its affiliates and protected by laws governing intellectual property and thereto related rights. Without limiting any rights related to this document, no part of this document may be copied, reproduced or transmitted in any form or by any means (electronic, mechanical, photocopying, recording, or otherwise), or for any purpose than expressed permission of Alfa Laval. Nor may it be used in any other way of for any other purpose than expressly permitted by Alfa Laval. Alfa Laval will enforce its rights related to this document to the fullest extent of the law, including the seeking of criminal prosecution.

Pharma-line S Double Tube Sheet Shell & Tube Heat Exchanger

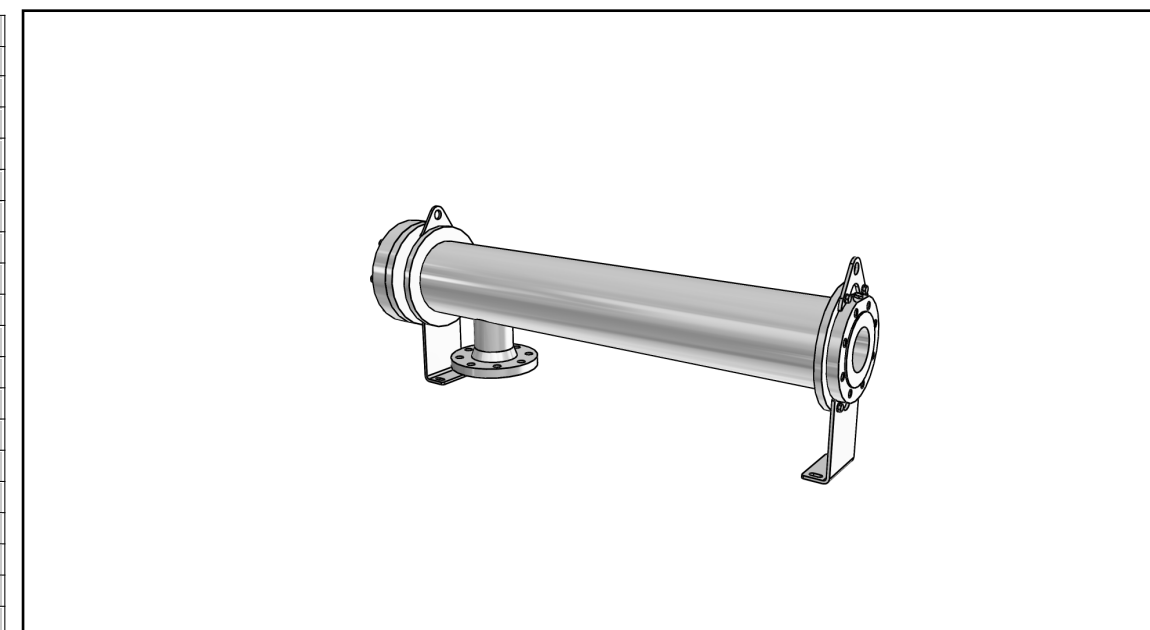
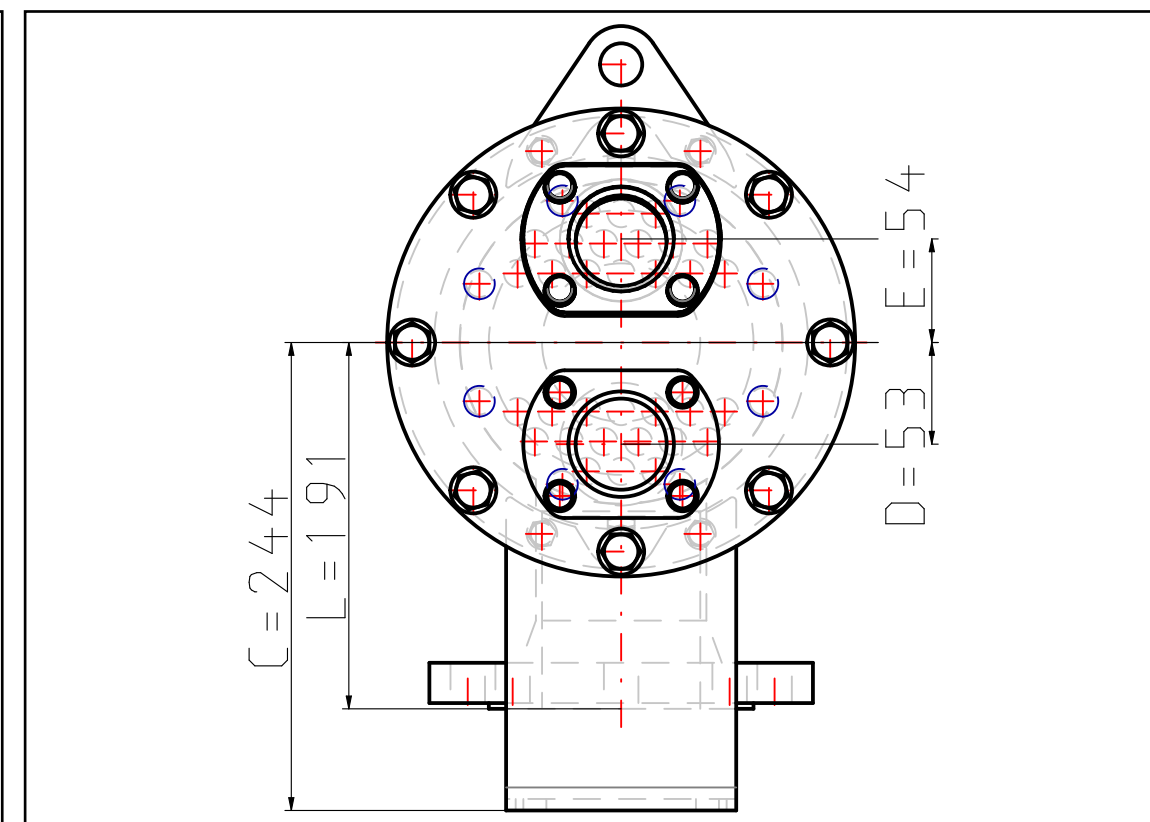
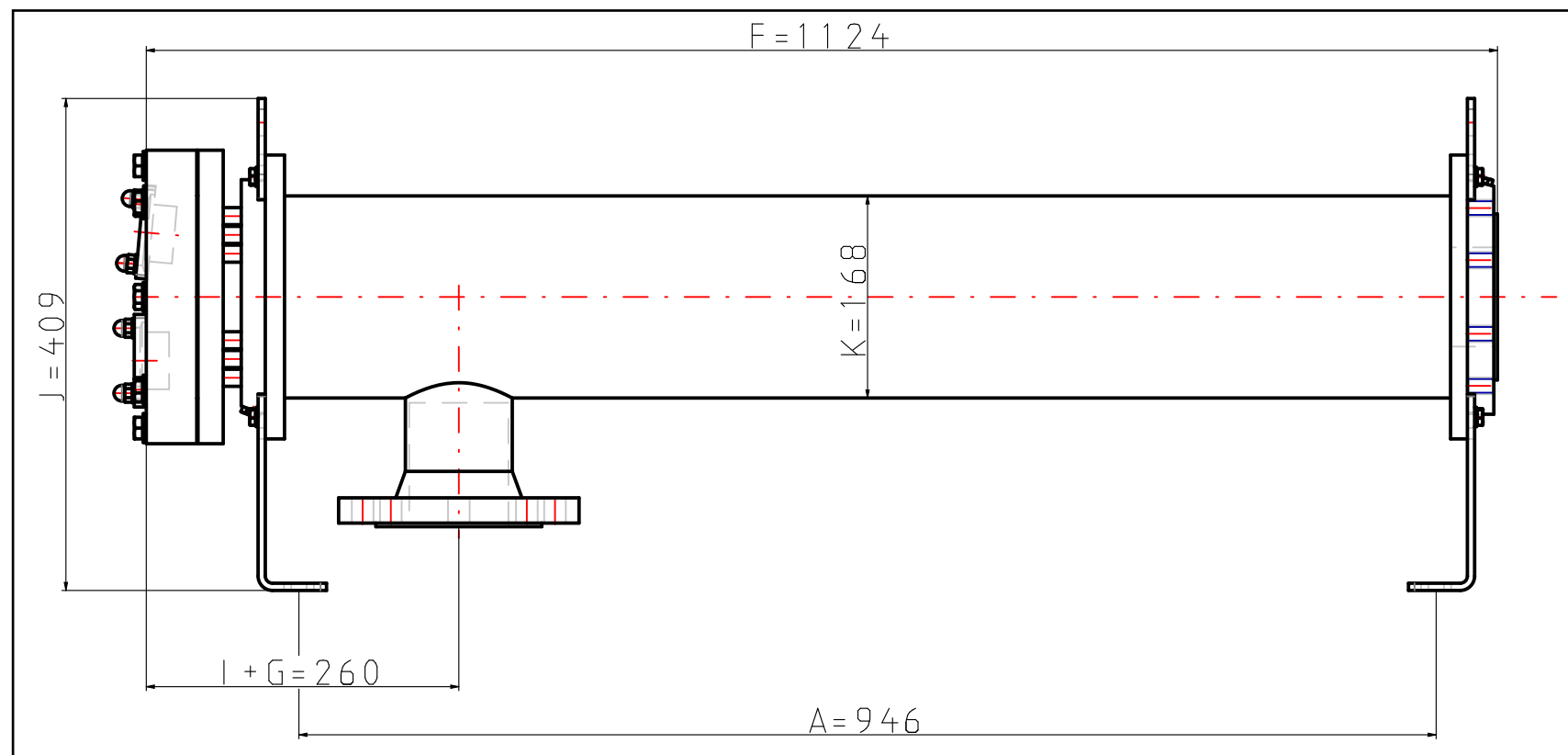

Item No	9615012519
Model name	Pharma-line S 1-1.2
Product connection size	NAC plate for Tri-clamp ASME BPE 2"
Shell connection size	Flange DN80
Item description	Pharma-line S 1-1.2 0,5MP PED
Extra description	IN ASME BPE 2" DIN2635DN80DN80
Volume shell side	12 l
Volume tube side	4.2 l
Weight empty	56 kg
Nozzles size Tube	ASME/OD 2"
Nozzle size flange	DIN2635/EN1092 DN 80
A (Distance)	946 mm
B (Diameter)	244 mm
C (Height)	244 mm
D (Distance)	53 mm
E (Distance)	54 mm
F (Length)	1124 mm
G (Distance)	127 mm
I (Distance)	133 mm
J (Height)	409 mm
L (Height)	191 mm
K (Diameter)	168 mm
Pressure vessel code	PED (directive 97/23/EC)
Design pressure / Shell side	-1/10 bar (g)
Design temperature / Shell side	-10/150 °C
Material / Shell side	SS 304/304L
Material / Media side (tube)	SS316L
Connection standard & size / Shell side	Flange: DIN2635/EN1092-1
Connection standard & size / Media side (tube)	NAC plate for Tri-clamp
Surface finish	Ra < 0,5µm MP on product wetted parts
Insulation	-

Qty	Pos	Item No	Description	Material	Weight (kg)
Edges broken to 0,4x45° or R0,5 Burrs removed		A3	Size	12/07/2016 06:45	Date
		MM	All Dimm. in	AL CAD Portal	Drawn by
			Title		Dept.
					Checked by
					Appr. by
					Std. Checked
					Prod. Checked
			Special requirements		
					Complementary document No.
					DRG No.
					9615012519
					1 OF 1

Only to the extent expressly agreed by us this document may constitute a contractual obligation on our part

Replaces drawing No	
Revision No	
Rev No	

Date		Checked		Appr.	
Revised					