

# Alfa Laval tank covers oval

## Tank covers

### Content

Oval cover Type O

Oval cover Type LKD 532 x 432

Oval cover Type LKD 532 x 432 flat lid

Oval cover Type LKD 542 x 446

Oval cover Type LKD 440 X 320

### Oval cover Type O

#### Introduction

The Alfa Laval Access Tank Cover - Oval Cover Type O is a stainless steel manway cover that provides a secure fit for openings of tanks or containers. It offers a quick, easy and convenient means of entry and egress to interiors of static tanks. It also provides a closeable means of access to the interior of the vessel, situated above or below the liquid level on the side of the tank.

#### Application

The Access Tank Cover - Oval Cover Type O is designed for use in a wide range of applications across the dairy, food, beverage, wine and many other industries.

For installation on the of tanks or vessels.

#### Benefits

- Versatility to cover all tank needs
- Swing flexibility due to optional hinge, for opening inwards, outwards or sideways

#### Standard design

The construction of Alfa Laval Tank covers varies, depending on the model. The Access Tank Cover - Oval Cover Type O consists of electropolished stainless steel cover and brushed frame with seals in EPDM, NBR, FPM or Q (silicone). To enable physical entry into the tank, the tank cover swings inwards or outwards, depending upon the model. Tank covers can be positioned above and below liquid level to meet different application requirements. Optional external and internal hinges are available to meet various requirements.



Alfa Laval Tank covers are available in AISI 304 or AISI 316L stainless steel. Surface finishes include electro-polished lid and brushed frame and vary from Ra 0.8 to Ra 3.0. In addition, 3.1 Material Certifications in accordance with EN 10204 are supplied with the cover. For more information, please refer to documentation and the Tank cover selection guide (.pdf 1 250 KB).

#### Working principle

Open the cover by loosening the handle. This range includes covers with various openings. For inspection purposes there are covers with inwards opening. If it is necessary to physically enter the tank there are covers with outwards and/or side-swing openings.

The 544x440 oval cover must be ordered according to the tank diameter in steps from 1.5 to 4 m. The 510x370 oval cover must be ordered according to the tank diameter in steps from 1.3 to 4 m. For a tank diameter between 1.5 and 2.1 m, the steps are 50 mm. If the tank diameter is between two steps, the higher diameter should be chosen when the tank diameter is 20 mm above one step. For tank diameter between 2.1 and 4.0 m, the steps are 100 mm. If the tank

diameter is between two steps, the higher diameter should be chosen when the tank diameter is 40 mm above one step.

## Certificates

3.1 (cover and frame are supplied with material certificate 3.1 according to EN10204).

## Physical data

Materials	
Steel parts:	1.4301 (304) or 1.4404 (316L)
Plastic parts:	Nylon
Seal:	EPDM, NBR, FPM or Silicone
Cover finish	
Internal:	Electropolished Less Ra 0.8 µm
Frame	
Internal:	Brushed Ra≥3.0 µm
External:	Brushed Ra≥3.0 µm
Temperature	
NBR:	-30 °C / 110 °C
SILICON (Q):	-50 °C / 200 °C
(EPDM, not oil or fat):	-15 °C / 90 °C
(FPM flourinated rubber):	-10° / 250° C

## Covers placed below liquid level

Cover shape	Type	Function	Pressure Range <sup>1</sup> bar
Oval	O-440X320IO	Static tank	1.3
Oval	O-490X395IO	Static tank	2.7
Oval	O-440X320IO	Static tank	1.3
Oval	O-510X370IO	Static tank	3.2
Oval	O-544X440IO	Static tank	2.8
Oval	O-542X446IO	Static tank	2.8
Oval	O-659x534IO	Static tank	4

<sup>1</sup> Calculated max. pressure (bar).

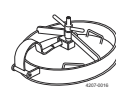

O-440x320IO  
External hinge

O-490x395IO

O-440x320IO  
Internal hinge

O-544x440IO

O-510x370IO

O-542x446IO

O-659x534IO

## Oval cover Type LKD 532 x 432



### Introduction

The Alfa Laval Access Tank Cover - Oval Cover Type LKD 532 x 432 is a stainless steel tank cover that provides a secure fit for openings of tanks or containers as well as quick, easy and convenient entry and egress to tank interiors.

Engineered for use on side of tanks or vessels in hygienic applications, the tank cover can be installed with an optional hinge that enables either right- or left-hand opening.

### Application

The Access Tank Cover - Oval Cover Type LKD 532 x 432 is designed for use in hygienic applications across the dairy,

food, and beverage industries. It is especially suitable for use on tanks or containers used for the production of dairy products.

### Benefits

- Hygienic design
- Available as a 3-A approved version
- Can withstand static pressure up to 2.5 bar

### Standard design

The construction of Access Tank Cover - Oval Cover Type LKD 532 x 432 varies, depending on the model. To enable visual inspection and/or physical entry into and egress out of the tank, the tank cover swings inwards and outwards. The tank cover can be positioned above or below the liquid level to meet different application requirements.

### Working principle

Open the cover by loosening the handle. For inspection purposes, the cover can then be turned into the tank. If physical entry into the tank is required, the cover can either be removed at the double hinge or swung out of the tank, depending on the model. Hygienically positioned, the seal is not affected by positive or negative pressure in the tank.

### Certificates



Authorized to carry the 3A symbol

### Technical data

#### Pressure

Max. static pressure:	2.5 bar (250 kPa)
Max. positive working pressure:	0 bar (0 kPa)
Max. negative working pressure:	0 bar (0 kPa)
Test pressure:	3.75 bar (375 kPa)

### Physical data

#### Materials

Steel parts:	1.4301 (304) or 1.4404 (316L)
Plastic parts:	Nylon
Seals (FDA):	EPDM, NBR, FPM or Q (silicone)

#### Standard lid surface finish

Product wetted surfaces:	Ra 0.8 µm
Other frame and lid spindle surfaces:	Ra 0.8 µm
External support and spindle surfaces:	Ra 3.0 µm

#### Acid Pickled

#### 3A surfaces finish

Product wetted surfaces:	Ra 0.8 µm (0.4 µm lid wetted surface)
Other frame and lid spindle surfaces:	Ra 0.8 µm (0.4 µm lid wetted surface)
External support and spindle surfaces:	Ra 3.0 µm

#### Electro polished

#### Temperature

Temperature range:	-30 °C / 110 °C (NBR)
--------------------	-----------------------

**Temperature**

EPDM:	-15 °C / 90 °C
NBR:	-30 °C / 110 °C
SILICONE (Q):	-50 °C / 200 °C
FPM:	-10 °C / 250 °C

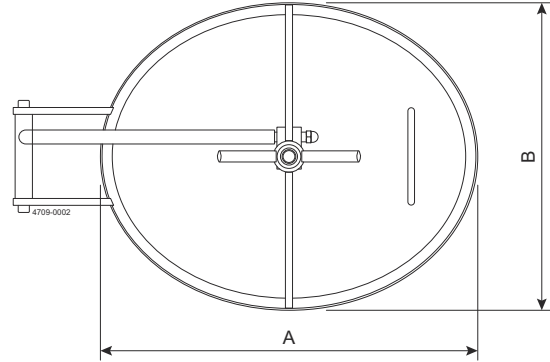
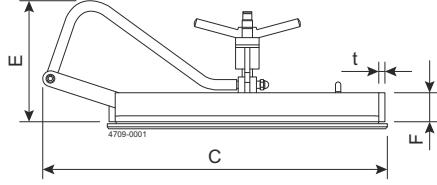
**Dimensions (mm)**

Type	LKD 532 x 432
A	532
B	432
C	663
E	265
F	(100) (60)
t	12
Cover thickness	3

## Oval cover Type LKD 532 x 432 flat lid



### Introduction

The Alfa Laval Access Tank Cover - Oval Cover Type LKD 532 x 432 flat lid is a stainless steel tank cover that provides a secure fit for openings of tanks or containers as well as quick, easy and convenient entry and egress to tank interiors.

Engineered for use on the side or bottom of tanks or vessels in hygienic applications, the tank cover can be installed with an optional hinge that enables either right- or left-hand opening.

### Technical data

Pressure	
Max. static pressure:	2.3 bar (230 kPa)
Max. negative working pressure:	0 bar
Test pressure:	3.75 bar (375 kPa)

### Physical data

Materials	
Steel parts:	1.4301 (304) or 1.4404 (316L)
Plastic parts:	Nylon
Seals (FDA):	EPDM, NBR, FPM or Q (silicone)

Standard lid surface finish	Acid Pickled
Product wetted surfaces:	Ra 0.8 µm (0.4 µm lid wetted surface)
Other frame and lid surfaces:	Ra 0.8 µm (0.4 µm lid wetted surface)
Other support and spindle surfaces:	Ra 3.0 µm

3A surface finish	Electro polished
Product wetted surfaces:	Ra 0.8 µm
Other frame and lid surfaces:	Ra 0.8 µm
Other support and spindle surfaces:	Ra 3.0 µm

Temperature	
Q:	-50 °C / 200 °C
EPDM:	-15 °C / 90 °C
FPM:	-10 °C / 250 °C
NBR:	-30 °C / 110 °C

Weight:	35.4 kg
---------	---------

### Application

The Access Tank Cover - Oval Cover Type LKD 532 x 432 flat lid is designed for use in hygienic applications across the dairy, food, beverage, and personal care industries. It is especially suitable for use on the bottom of tanks or containers.

### Benefits

- Hygienic design
- Suitable for installation on the bottom on the tank
- Can withstand static pressure up to 2.3 bar

### Standard design

The Access Tank Cover - Oval Cover Type LKD 532 x 432 flat lid can be positioned above or below the liquid level to meet different application requirements.

### Working principle

Open the cover by loosening the handle. For inspection purposes, the cover can then be turned into the tank. If physical entry into the tank is required, the cover can either be removed at the double hinge or swung out of the tank. Hygienically positioned, the seal is not affected by positive or negative pressure in the tank.

### Certificates

3.1 (cover and frame are supplied with material certificate 3.1 according to EN10204).

Dimensions (mm)

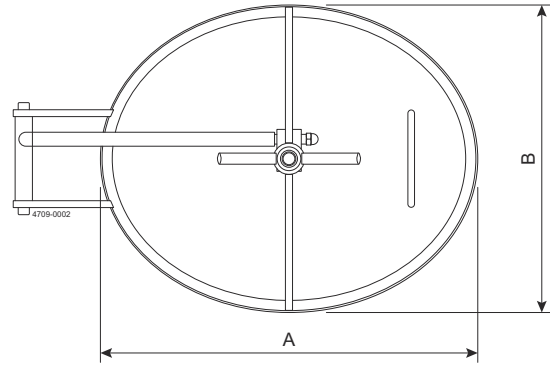
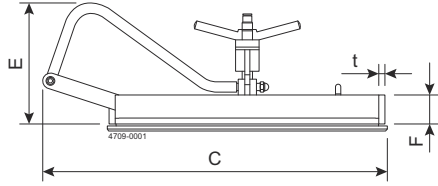

Type	LKD 532 x 432 flat lid
A:	532
B:	432
C:	662
E:	262
F:	100
t:	12
Cover thickness:	10

## Oval cover Type LKD 542 x 446



### Introduction

The Alfa Laval Access Tank Cover – Oval Cover Type LKD 542 x 446 is a stainless steel tank cover that provides a secure fit for openings of tanks or containers as well as quick, easy and convenient entry and egress to tank interiors. It is engineered for use on the side of tanks or vessels.

### Application

The Access Tank Cover – Oval Cover Type LKD 542 x 446 is mainly designed for use in the beverage, and brewery

industries. It is especially suitable for use on tanks or containers that require a closeable means of access to the interior of the vessel. It features an angled, shaped frame to ensure a shadowless installation.

### Benefits

- The angled frame design makes the cover more cleanable
- Can withstand up to 2.8 bar static pressure

### Standard design

The construction of the Access Tank Cover – Oval Cover Type LKD 542 x 446 varies, depending on the model. To enable visual inspection and/or physical entry into the tank, the tank cover swings inwards and outwards. The tank cover can be positioned above or below the liquid level to meet different application requirements.

### Working principle

Open the cover by loosening the handle. For inspection purposes, the cover can then be turned into the tank. If physical entry into the tank is required, the cover can either be removed at the double hinge or swung out of the tank, depending on the model. Hygienically positioned, the seal is not affected by positive or negative pressure in the tank.

### Certificates

3.1 (cover and frame are supplied with material certificate 3.1 according to EN10204).

## Technical data

### Pressure

Max. static pressure:	2.8 bar (280 kPa)
Max. positive working pressure:	0 bar (0 kPa)
Max. negative working pressure:	0 bar (0 kPa)
Test pressure:	4.2 bar (420 kPa)

## Physical data

### Materials

Steel parts:	1.4301 (304) or 1.4404 (316L)
Plastic parts:	Nylon
Seals (FDA): (Lip seal design):	EPDM, NBR, FPM or Q (silicone)

### Standard surface finish

	Acid Pickled
Product wetted surfaces:	Ra 0.8 µm
Other frame and lid surfaces:	Ra 0.8 µm
Other support and spindle surfaces:	Ra 3.0 µm

### Temperature

EPDM:	-15 °C / 90 °C
NBR:	-30 °C / 110 °C
SILICONE (Q):	-50 °C / 200 °C
FPM:	-10 °C / 250 °C

Weight:	12 kg
---------	-------

Dimensions (mm)

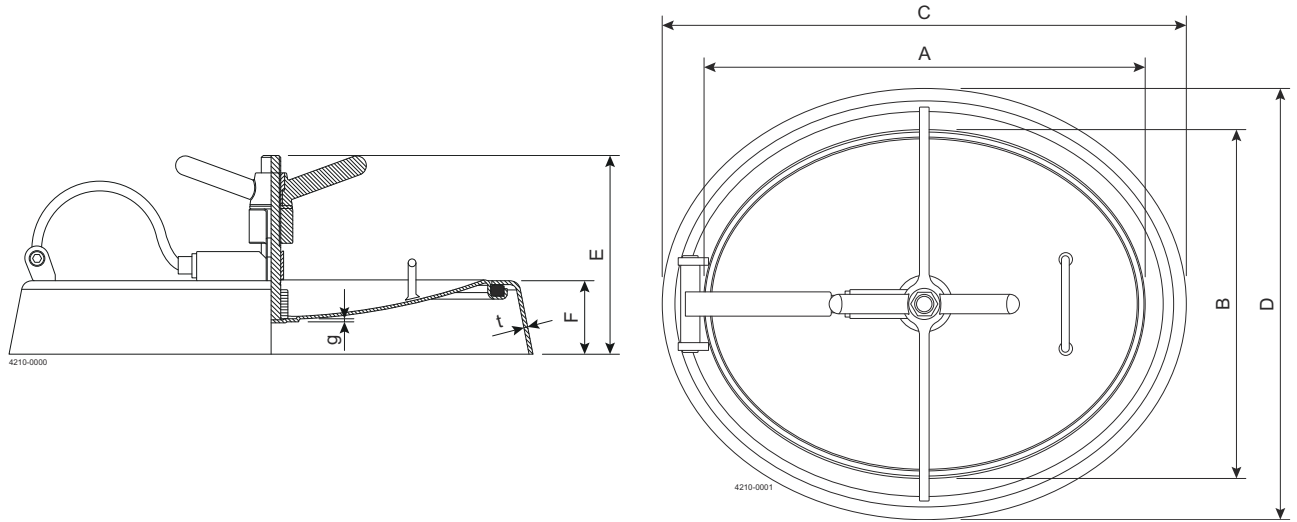

Type	LKD 542 x 446
A:	461
B:	362
C:	542
D:	446
E:	202
F:	76
t:	4
g:	3



## Oval cover Type LKD 440 X 320



### Introduction

The Alfa Laval Access Tank Cover – Oval Cover Type LKD 440 x 320 is a stainless steel tank cover that provides a secure fit for openings of tanks or containers. It is engineered for use on the side of tanks or vessels in hygienic applications.

### Application

The Access Tank Cover – Oval Cover Type LKD 440 x 320 is designed for use in hygienic applications across for the food, beverage, personal care and wine industries. It is especially suitable for tanks used for the production of wine and juice.

### Technical data

Pressure	
Max. static pressure:	1.5 bar (150 kPa)
Max. positive working pressure:	0 bar (0 kPa)
Max. negative working pressure:	0.5 bar (50 kPa)
Test pressure:	2.25 bar (225 kPa)

### Physical data

Materials	
Steel parts:	1.4301 (304) or 1.4404 (316L)
Plastic parts:	Nylon
Seals (FDA):	EPDM, NBR, FPM or Q (silicone)

3A surface finish	Electropolished
Product wetted surfaces:	Ra 0.8µm (0.4 µm lid wetted surface)
Other lid and frame surfaces:	Ra 0.8µm (0.4 µm lid wetted surface)
External support and spindle:	Ra 3.0 µm

Temperature	
Q	-50 °C / 200 °C
EPDM	-15 °C / 90 °C
FPM	-10 °C / 250 °C
NBR	-30 °C / 110 °C

Weight:	7.8 kg
---------	--------

### Benefits

- Versatility to cover all tank needs
- Hygienic design
- Available as a 3-A approved version

### Standard design

The construction of Access Tank Cover – Oval Cover Type LKD 440 x 320 enables visual inspection into the tank. The tank cover swings outwards and can be positioned above or below the liquid level to meet different application requirements.

Available in standard and pressure models for use both above and below the liquid level, the tank cover complies with the U.S. Food and Drug Administration (FDA) and the European 1935/2004/EC Declarations of Conformity.

### Working principle

Open the cover by loosening the handle. For inspection purposes, the cover can then be turned into the tank. If physical entry into the tank is required, the cover can either be removed at the double hinge or swung out of the tank, depending on the model. Hygienically positioned, the seal is not affected by positive or negative pressure in the tank.

### Certificates

3.1 (cover and frame are supplied with material certificate 3.1 according to EN10204).



Authorized to carry the 3A symbol

Dimensions (mm)

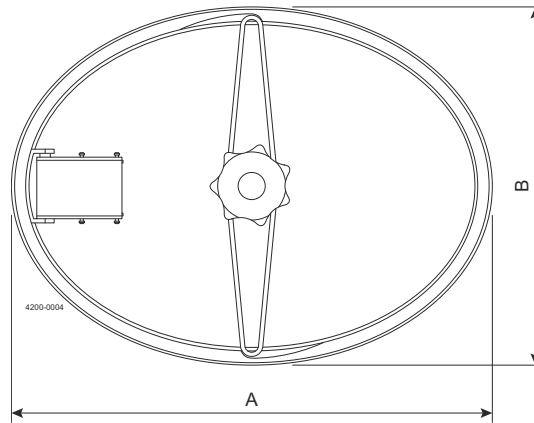

Type	LKD 440 x 320
A	440
B	320
E	160
F	60
t	8
Cover thickness	2

This document and its contents are subject to copyrights and other intellectual property rights owned by Alfa Laval AB (publ) or any of its affiliates (jointly "Alfa Laval"). No part of this document may be copied, re-produced or transmitted in any form or by any means, or for any purpose, without Alfa Laval's prior express written permission. Information and services provided in this document are made as a benefit and service to the user, and no representations or warranties are made about the accuracy or suitability of this information and these services for any purpose. All rights are reserved.

**How to contact Alfa Laval**

Up-to-date Alfa Laval contact details for all countries are always available on our website at [www.alfalaval.com](http://www.alfalaval.com)