

Installation Manual Plate Heat Exchanger

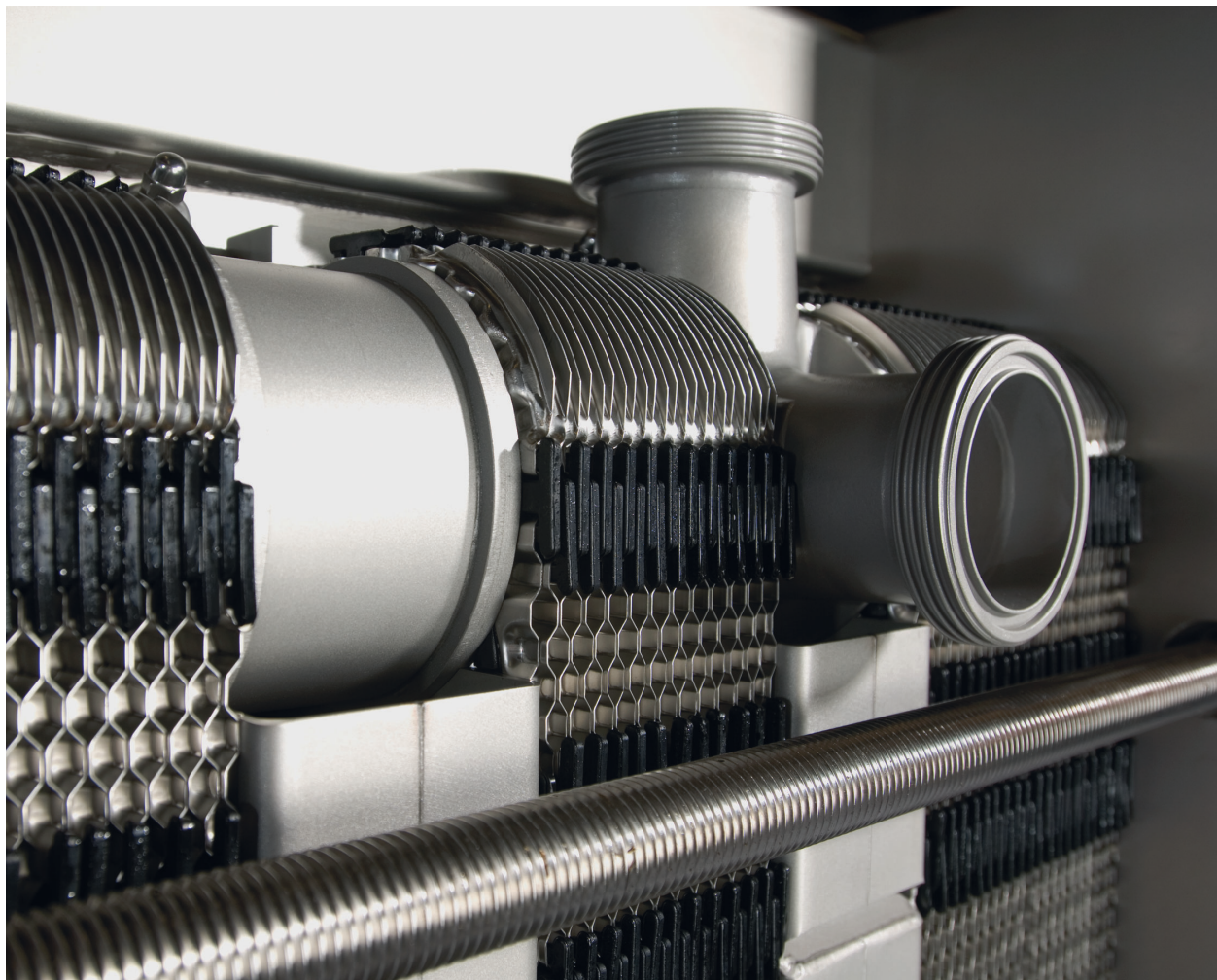

Tetra Pak® Plate Heat Exchanger

Lit. Code 200010676-2-EN-GB

**Manufactured by Alfa Laval for Tetra Pak
Supplied and serviced by Tetra Pak**

Always contact your local Tetra Pak representative, also where this manual states references to Alfa Laval.

How to contact Tetra Pak:

Contact details for all countries are continually updated on our website.

Please visit www.tetrapak.com and contact your local Tetra Pak representative

Published by
Alfa Laval Technologies AB
Box 74
SE-221 00 Lund, Sweden
Telephone switchboard: +46 46 36 65 00
info@alfalaval.com

The original instructions are in English

© Alfa Laval AB 2024-02

This document and its contents are subject to copyrights and other intellectual property rights owned by Alfa Laval AB (publ) or any of its affiliates (jointly "Alfa Laval"). No part of this document may be copied, re-produced or transmitted in any form or by any means, or for any purpose, without Alfa Laval's prior express written permission. Information and services provided in this document are made as a benefit and service to the user, and no representations or warranties are made about the accuracy or suitability of this information and these services for any purpose. All rights are reserved.



English

Use the QR code, or visit www.alfalaval.com/tetrapak-manuals, to download a local language version of the manual.

العربية

، لتتنزيل إصدار اللغة المحلية للدليل ، استخدم رمز الاستجابة السريعة أو قم بزيارة www.alfalaval.com/tetrapak-manuals

български

Използвайте QR кода или посетете следния адрес www.alfalaval.com/tetrapak-manuals, за да свалите версия на ръководството за употреба на Вашия език.

Český

Použijte kód QR nebo navštivte www.alfalaval.com/tetrapak-manuals a stáhněte si místní jazykovou verzi tohoto návodu.

Dansk

Brug QR-koden, eller følg www.alfalaval.com/tetrapak-manuals for at downloade en lokal sprogversion af manualen.

Deutsch

Verwenden Sie den QR-Code oder besuchen Sie www.alfalaval.com/tetrapak-manuals, um die lokale Sprachversion des Handbuchs herunterzuladen.

ελληνικά

Χρησιμοποιήστε τον κωδικό QR ή επισκεφτείτε τη σελίδα www.alfalaval.com/tetrapak-manuals, για να κατεβάσετε μια έκδοση του εγχειριδίου στην τοπική σας γλώσσα.

Español

Utilice el código QR o visite www.alfalaval.com/tetrapak-manuals para descargar una versión del manual en el idioma local.

Eesti

Kasutusjuhendi kohaliku keeleversiooni allalaadimiseks kasutage QR-koodi või külastage aadressi www.alfalaval.com/tetrapak-manuals.

Suomi

Käytä QR-koodia tai avaa osoite www.alfalaval.com/tetrapak-manuals, niin voit ladata käyttöohjeen paikallisella kielellä.

Français

Utilisez le QR-code ou rendez-vous sur le site www.alfalaval.com/tetrapak-manuals, pour télécharger une version du manuel dans la langue locale.

Hrvatski

Upotrijebite QR kod ili posjetite www.alfalaval.com/tetrapak-manuals ako želite preuzeti verziju priručnika na lokalnom jeziku.

Magyar

Használja a QR-kódot, vagy látogasson el a www.alfalaval.com/tetrapak-manuals webhelyre a kézikönyv helyi nyelvű változatának letöltéséhez.

Italiano

Utilizzate il codice QR o visitate il sito www.alfalaval.com/tetrapak-manuals per scaricare una versione del manuale nella lingua locale.

日本語

コード、または www.alfalaval.com/tetrapak-manuals、現地語版のマニュアルをダウンロードすることができます。

한국어

코드를 사용하거나 www.alfalaval.com/tetrapak-manuals 에서 사용 설명서의 해당 언어 버전을 다운로드 하십시오.

Lietuvos

Naudokite greitojo atsako (QR) kodą arba apsilankykite www.alfalaval.com/tetrapak-manuals, kad atsisiųstumėte vadovo vietos kalbos versiją.

Latvijas

Lai lejupielādētu rokasgrāmatas versiju vietējā valodā, izmantojiet QR kodu vai apmeklējiet www.alfalaval.com/tetrapak-manuals.

Nederlands

Gebruik de QR-code, of bezoek www.alfalaval.com/tetrapak-manuals om een handleiding in een andere taal te downloaden.

Norsk

Brug QR-koden, eller gå til www.alfalaval.com/tetrapak-manuals for å laste ned en versjon av håndboken på et lokalt språk.

Polski

Aby pobrać instrukcję w innej wersji językowej, zeskanuj kod QR lub otwórz stronę www.alfalaval.com/tetrapak-manuals.

Português

Utilize o código QR ou visite www.alfalaval.com/tetrapak-manuals para descarregar uma versão do manual na língua local.

Português do Brasil

Use o QR ou visite www.alfalaval.com/tetrapak-manuals para baixar uma versão do manual no idioma local.

Românesc

Utilizați codul QR sau vizitați www.alfalaval.com/tetrapak-manuals, pentru a putea descărca o versiune a manualului în limba dumneavoastră.

Русский

Чтобы загрузить руководство на другом языке, воспользуйтесь QR-кодом или перейдите по ссылке www.alfalaval.com/tetrapak-manuals.

Slovenski

Če želite prenesti lokalno jezikovno različico priročnika, uporabite kodo QR ali obiščite spletno stran www.alfalaval.com/tetrapak-manuals.

Slovenský

Použite QR kód alebo navštívte stránku www.alfalaval.com/tetrapak-manuals a stiahnite si verziu príručky v miestnom jazyku.

Svenska

Använd QR-koden eller besök www.alfalaval.com/tetrapak-manuals för att hämta en lokal språkversion av bruksanvisningen.

Türkçe

Kılavuzun yerel dildeki versiyonunu indirmek için QR kodunu kullanın veya www.alfalaval.com/tetrapak-manuals adresini ziyaret edin.

中国

请使用二维码或访问 www.alfalaval.com/tetrapak-manuals，以下载本地语言版本的手册。

Contents

1	Introduction	7
1.1	Description	7
1.1.1	Components	7
1.1.2	Type plate	9
1.2	Intended use	11
1.3	Reasonably foreseeable misuses	11
1.4	Prior knowledge to handle the equipment	11
1.5	Available technical information	11
1.6	Warranty conditions	12
1.7	Advice	12
1.8	Environmental compliance	13
2	Safety	15
2.1	Safety considerations	15
2.2	Definitions of expressions	15
2.3	Personal protective equipment	16
2.4	Working at height	17
3	Storage	19
3.1	Storage of equipment	20
4	Installation	21
4.1	Installation workflow	21
4.2	Components	22
4.3	Before installation, lifting and transport	25
4.4	Crate handling	27
4.4.1	Crate — Inspection	27
4.4.2	Lifting and transportation of crated equipment	28
4.5	Unpacking the crate	31
4.5.1	Manufactured sides — Open	32
4.5.2	Flip box — Open	33
4.5.3	Crafted sides — Open	34
4.5.4	Inspection after uncrating	35
4.6	Lifting the equipment	36
4.6.1	Securing devices	39
4.6.2	Lifting using lifting device	40
4.6.3	Lifting using lifting wire	41
4.6.4	Lifting using lifting eye bolts	43
4.6.5	Lifting using swivel eye bolt	44
4.6.6	Lifting using hoist slings	46
4.7	Raising	49

4.7.1	Raising using lifting eye bolts.....	49
4.7.2	Raising using hoist slings on pressure plate.....	53
4.7.3	Raising using hoist slings around the plate heat exchanger.....	57
4.8	Assembly of feet.....	61
4.9	Transport covers.....	63
4.10	Inspection before installation.....	64
4.11	Start-up.....	65
4.11.1	Connections.....	68

1 Introduction

This manual provides information needed to handle and install a plate heat exchanger.

1.1 Description

1.1.1 Components

This section describes the components of the plate heat exchanger that are referred to in this manual. For further description of a plate heat exchanger components see the maintenance manual.

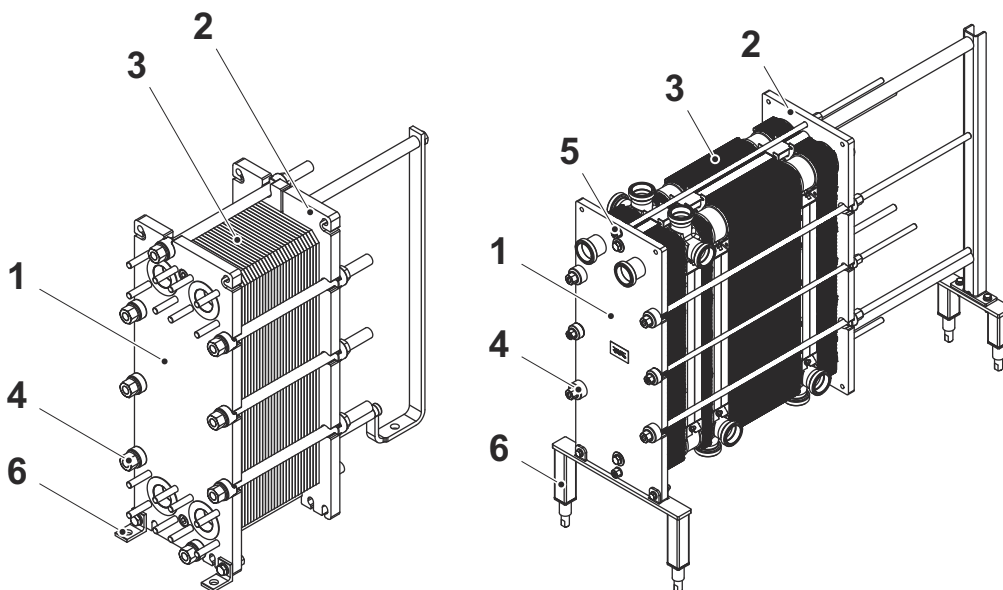

Main components

1. Frame plate

Fixed plate with a various number of portholes for the connection of the piping system. The carrying and guiding bar are attached to the frame plate.

2. Pressure plate

Moveable plate that can contain a various number of portholes for connection of the piping system. The functionality of the pressure plate is to compress the plate pack against the frame plate

3. Plate pack

Heat is transferred from one media to the other through the plates. The plate pack consists of:

- channel plates and end plates
or for semi-welded units:
- twin plate cassette
- gaskets
- transition plates (in some cases)

The plate pack can also be divided into sections according to the plate heat exchanger to the right in the illustration. The bigger plates between the sections are called partition plates or connection plates depending on the design.

4. Tightening bolts

The bolts with bearing boxes are identified as tightening bolts.

5. Locking bolts

The remaining bolts assembled to keep the frame plate and the pressure plate in place. Often shorter than the tightening bolts.

6. Foot

A part that can be fixed or adjustable. It can also be used to secure the plate heat exchanger to the foundation using bolts.

1.1.2 Type plate

The type plate is in most cases assembled on the frame plate. It may also be assembled on the pressure plate. The type plate can be a plate of steel or a sticker label.



WARNING Risk of damage to equipment.

The design pressure and the design temperature are both marked on the type plate. These must not be exceeded.



CAUTION Risk of damage to equipment.

Avoid aggressive chemicals for cleaning the plate heat exchanger when a sticker label is used.

The design pressure (11) and the design temperature (10), as given on the type plate, are the values against which the plate heat exchanger is approved according to the pressure vessel code in question. The design temperature (10) may exceed the recommended operating temperature (8) for the gaskets. If the operating temperatures as specified on the plate heat exchanger drawing are to be changed the supplier should be consulted.

1. Space for logotype
2. Website for service
3. Website for service (for industrial products)
or
Drawing of possible locations of connections (for hygienic products)
4. Space for mark of approval
5. Warning, read manual
6. Date of pressure test
7. Maximum operating temperature
8. Manufacturer test pressure (PT)
9. Allowable temperatures Min./Max. (TS)
10. Allowable pressures Min./Max. (PS)
11. Volume of each channel (V)
12. Locations of the connections for each fluid
13. Fluid classification group
14. Year of manufacture
15. Serial number
16. Product model
17. Manufacturer's name

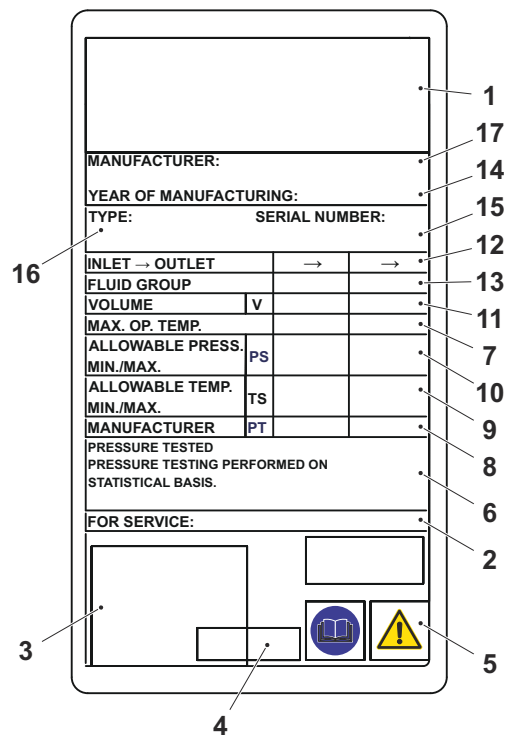
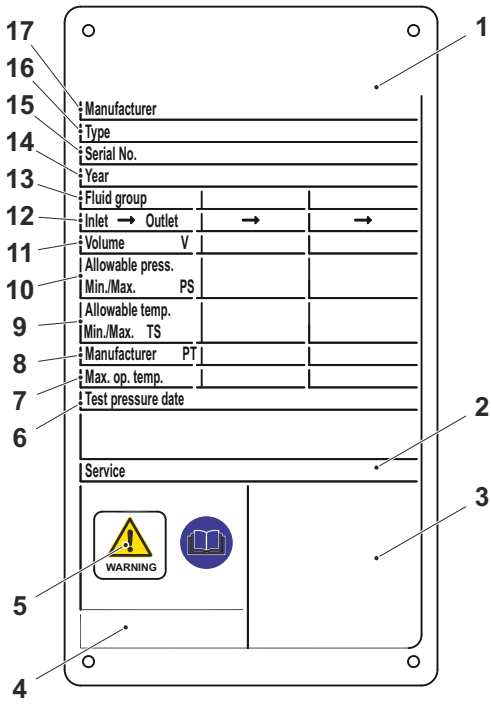

Example of type plates.

1.2 Intended use

The intended use of this equipment is to transfer heat in accordance with a decided configuration for a given thermal duty.

Alfa Laval will not be held responsible for injury or damage if the equipment is used for any other purpose than the intended use described above. All other use is prohibited.

1.3 Reasonably foreseeable misuses

- Do not lift or transport the crate nor the equipment in any other way than stated in the *Installation Manual*.
- Connect a pipe in the way it is meant to be connected to the plate heat exchanger. Gasket and lining can be damaged if a pipe is connected in the wrong way.
- For semi-welded models and other models with asymmetric configuration it is a safety issue if the wrong pipe is connected to the wrong port. Ensure that the correct media is connected to the correct port according to the plate heat exchanger drawing.
- There is a risk to damage the hangers if many plates are hung or moved at a time. It is recommended to handle one, or maximum two, plates at a time.
- When tightening to the A-measurement (the distance between the inside of the frame plate and the inside of the pressure plate), always tighten the bolts crosswise, evenly, and a little at a time to avoid diagonal shifting and snaking. The number of plates and the A-measurement can be found on the plate heat exchanger drawing.
- Increase and decrease flow gently to avoid plate deformations and gasket blow-outs by for example water hammer.
- At start-up, raise the temperature gently to avoid cracks in the gaskets or create a blow-out. See Section *Start-up* in the *Installation Manual*.
- If the plate heat exchanger will not be in operation for a long period of time, follow the instructions in Section *Storage*.

1.4 Prior knowledge to handle the equipment

The plate heat exchanger shall be operated by personnel who have studied the instructions in this manual and have knowledge of the process where the heat exchanger is installed. This includes knowledge of precautions regarding media type, pressures, temperatures in the plate heat exchanger as well as process specific precautions.

Maintenance and installation of the plate heat exchanger shall be done by persons who have knowledge and authorization according to local regulations. This may include work with piping, welding and other kinds of maintenance.

For maintenance actions not described in this manual, contact Alfa Laval for advice.

1.5 Available technical information

In addition to this manual, please keep the following documentation at hand:

- **Declaration of Conformity**
If applicable.
- **Parts list**
A list of components included in the configuration of the product.
- **Plate hanging list**
A description of the included plates and gaskets and the sequence that they are installed in the plate heat exchanger.
- **Plate heat exchanger drawing**
A drawing of the delivered plate heat exchanger.

The listed documents are unique for the delivered product.

1.6 Warranty conditions

The warranty conditions are usually included in the signed sales contract prior to the order of the delivered plate heat exchanger. Alternatively, the warranty conditions are included in the sales offer documentation or with a reference to the document specifying the valid conditions. If faults occur during the specified warranty period, always consult Alfa Laval for advice.

1.7 Advice

Always consult Alfa Laval for advice if:

- The number of plates are intended to be changed.
- Operating temperatures and pressures are to be changed, or if other fluids are to be processed in the plate heat exchanger.

1.8 Environmental compliance

If operating Alfa Laval's heat exchangers in an optimal way and following the maintenance recommendations, this will maximize the energy savings and minimize the operational expenses (OPEX).

Waste management

Separate, recycle, or dispose all material and components in a safe, and environmentally responsible way according to national legislation or local regulations. If there is any uncertainty regarding what material a component is made of, contact the local Alfa Laval sales company.

Unpacking

Packing material consists of wood, plastics, cardboard boxes and, in some cases, metal straps.

- Wood and cardboard boxes can be reused, recycled or used for energy recovery.
- Plastics should be recycled or burnt at a licensed waste incineration plant.
- Metal straps should be sent for material recycling.

This page is intentionally left blank.

2 Safety

2.1 Safety considerations

The plate heat exchanger shall be used and maintained in accordance with Alfa Laval's instructions in this manual. Incorrect handling of the plate heat exchanger may result in serious consequences with injuries to persons and/or property damage. Alfa Laval will not accept responsibility for any damage or injury resulting from not following the instructions in this manual.

The plate heat exchanger should be used in accordance with the specified configuration of material, media types, temperatures and pressure for the specific plate heat exchanger.

2.2 Definitions of expressions



WARNING Type of hazard

WARNING indicates a potentially hazardous situation which, if not avoided, could result in death or serious injury.



CAUTION Type of hazard

CAUTION indicates a potentially hazardous situation which, if not avoided, may result in minor or moderate injury.



NOTE

NOTE indicates a potentially hazardous situation which, if not avoided, may result in property damage.



Safety

2.3 Personal protective equipment

Protective shoes

Shoes with reinforced toe cap. Minimize foot injuries caused by dropped articles.



Protective helmet

Helmet designed to protect the head from accidental injury.



Protective goggles

Tight-fitting eyeglasses worn to protect the eyes from hazards.



Protective gloves

Gloves that protect the hands from hazards.



Safety

2.4 Working at height

**WARNING Risk of falling.**

For any kind of work at height, always ensure that safe means of access is available and used. Follow local regulations and guidelines for work at height. Use scaffolds or a mobile work platform and a safety harness. Create a safety perimeter around the working area and secure tools or other objects from falling.

If the installation requires working at a height of two meters or higher, safety arrangements must be taken in consideration.



Safety



Safety

This page is intentionally left blank.

3 Storage

**WARNING Risk of damage to equipment.**

The crate is not designed to be stacked.

Never store anything on top of the crate.

If nothing else has been agreed, Alfa Laval delivers the plate heat exchanger ready to be put into service upon arrival.

Alfa Laval and its representatives reserve the right to inspect the storage space and/or equipment whenever necessary until the expiration of the warranty period stipulated in the contract. Notification must be given 10 days prior to the date of inspection.

If there is any uncertainty about the storage of the plate heat exchanger, consult an Alfa Laval representative.

3.1 Storage of equipment

It is recommended to store the plate heat exchanger indoors, but if this is not possible, make sure to protect the heat exchanger against the weather.

- Make sure that the connections are covered.
- Protect the heat exchanger from sun light, for example by covering with non-transparent plastic film. UV-light will shorten the lifetime of the rubber gaskets.
- The heat exchanger should not be exposed to ozone, organic solvents or acids. Avoid storage in engine rooms or close to welding equipment.
- The tightening and locking bolts should be well covered with a thin layer of grease. See the *Maintenance manual* Section *Closing*.
- Beware that extreme temperatures can shorten the lifetime of the gaskets.

Long time storage before taken in operation

If the plate heat exchanger must be stored for an extensive period of time, longer than one year, the risk of leakage when starting up increases. To avoid this problem it is recommended to let the gasket rubber rest to regain most of its elasticity.

1. Loosen the tightening bolts and the locking bolts. Follow the instructions in the *Maintenance manual*.
2. Open the plate heat exchanger until the plate package measurement is $1.25 \times A$.
3. Leave the plate heat exchanger for 24–48 hours, the longer the better, for the gaskets to relax.
4. Re-tighten according to the instructions in the *Maintenance manual*.
5. Alfa Laval recommends a leakage test should be carried out, see Section *Leakage test* in the *Maintenance manual*.

4 Installation

4.1 Installation workflow

An installation of any Alfa Laval equipment follows the installation process described below. Follow the relevant steps depending on the installation agreement and operating industry.

Step	Process activity	End state	Note
1	Preparations	Site prepared. Equipment at prepared site.	
2	Cleaning of pipes	Pipes free from dust, dirt and other foreign particles that can clog the plate heat exchanger.	It is recommended to install a inline strainer before the plate heat exchanger inlet.
3	Mechanical completion	Equipment mechanically installed.	Also includes connection to the process equipment piping.
4	Cleaning	Equipment cleaned and ready for production.	Only relevant for some industries. Check with installation responsible. Follow the cleaning instructions in the Maintenance Manual.
5	Commissioning	Equipment commissioned and functionally validated	Only valid if agreed upon.
6	Performance validation	Equipment performance validated.	
7	Hand over	Contract fulfilled.	

4.2 Components

The installation manual, this manual, is divided into sections corresponding to components used with any plate heat exchanger. Among the delivered document, see Section *Delivered technical information* there is a list of all components included in your specific plate heat exchanger. The table below show the name and design of each component included in a headline regarding lifting and raising in this manual.

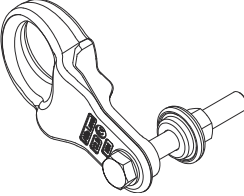
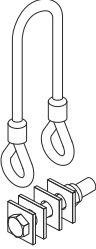
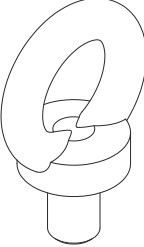
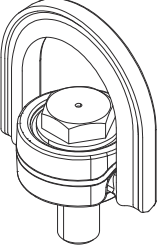
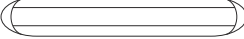
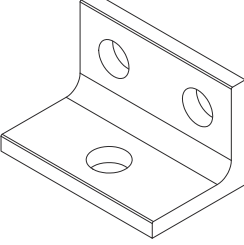
Denomination	Design
Lifting device	
Lifting wire	
Lifting eye bolt	
Swivel eye bolt	
Hoist sling	
L-foot	

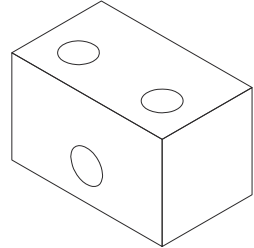
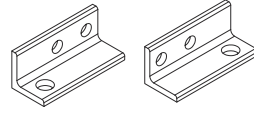
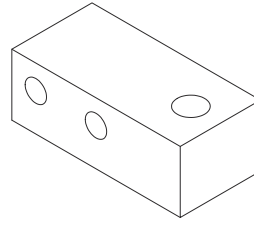
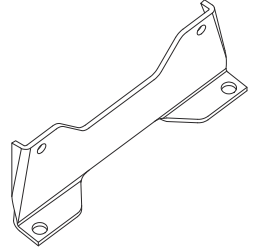
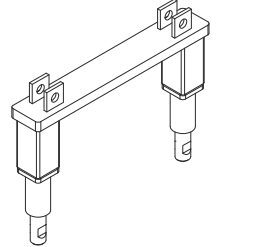
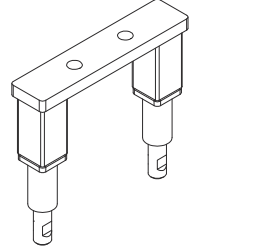
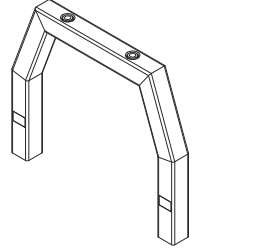
Denomination	Design
Block foot	
Swing foot L-foot	
Swing foot block foot	
Fixed foot	
Low adjustable foot frame plate	
Low adjustable foot supporting column	
High adjustable foot frame plate	

Denomination

Design

High adjustable foot supporting column

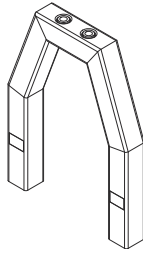

Stabilising bar

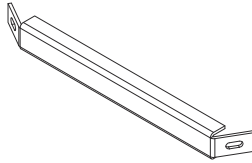

4.3 Before installation, lifting and transport

 **CAUTION** Risk of damage to equipment.

During installation or maintenance, precautions must be taken to avoid damaging the plate heat exchanger and its components. Damage to components can adversely affect the performance or serviceability of the plate heat exchanger.

 **WARNING** Risk of personal injury.

The equipment is heavy.

Never lift or move the equipment manually.

 **WARNING**

Identification of connections to welded channel and gasketed channel are vital. Entering wrong media into the gasketed channel can cause serious personal injuries and severely damage the gaskets.

If any hesitation in this matter contact Alfa Laval representative.

To consider before installation

- Keep the plate heat exchanger packed until installation.
- Before connecting any piping, make sure all foreign objects have been flushed out of the piping system that should be connected to the plate heat exchanger.
- Before connecting any piping, make sure that all the bolts for the feet are tightened and that the plate heat exchanger is firmly fixed to the foundation.
- Before start-up, check that all the tightening bolts are firmly tightened and that the plate pack has the correct measurements (A measure). See the plate heat exchanger drawing.
- The pipework must be able to handle unforeseen loads so that the plate heat exchanger is not exposed for pressure peaks, thermal expansion, or vibrations.
- Keep the pressure variation as low as possible.
- Safety valves shall be installed according to current pressure vessel regulations.
- It is recommended that protection sheets are used to cover the plate pack, this to prevent personal injury caused by leakage of hot or aggressive fluids from the plate pack. Also to prevent injuries from touching the hot plates.
- Secure that the opening time of valves is sufficiently slow to avoid pressure surges.
- Make sure that no air remains inside the plate heat exchanger.

- If the plate heat exchanger surface temperature is expected to be hot or cold, take protective actions, such as insulate the plate heat exchanger, to avoid risk for personnel injuries. Always ensure that required actions are according to local regulations.
- Design pressures and temperatures for each model are marked on the type plate. These shall not be exceeded.
- Check the condition of the flooring.
- Always check the centre of gravity before unpacking or moving the equipment. Keep the centre of gravity as low as possible.
- Always move the equipment slow and steady.

Refrigeration



WARNING Risk of damage to equipment

Full vacuum conditions shall apply at start up for refrigeration duties to avoid moisture and air in the plate heat exchanger.

- Since most refrigeration systems contain compressor oil, it must be possible to drain this oil out from the system, either manually or automatically. If not drained, compressor oil will end up in the plate heat exchanger and cause fouling. This will lead to poor performance in the plate heat exchanger when the oil film thickness is too thick or when oil is accumulated in the port or in the channels.

Risk assessment

Always perform a thorough risk assessment before lifting and transporting the crated or uncrated equipment on every handling occasion.

4.4 Crate handling



WARNING Risk of personal injury.





Lifting and transport of the crated and uncrated equipment must be carried out by skilled persons. See *Prior knowledge* in Chapter *Introduction*.

The plate heat exchanger is delivered on a pallet and can be packed in a crate or wrapped in stretch film. There are three main versions of crates:

- Manufactured sides — sides and a top made in separate pieces
- Flip box — a box with hinges in the sides and a loose top
- Crafted sides — sides and top crafted board by board when packed for delivery

The centre of gravity is marked on the crate or the wrapping.

A crate is also marked with other symbols according to the table.

Symbol	Meaning
	Centre of gravity
	Do not stack on top
	Fragile
	This way up

4.4.1 Crate — Inspection

Examine the outside of the crates before starting to unload and report any transport damage. Contact the insurance company in case of any damages.

4.4.2 Lifting and transportation of crated equipment

 **WARNING Risk of personal injury.**

The equipment is heavy and sensitive and must be handled with precaution.

Unauthorized personnel is not allowed to be in the defined risk areas when the crated or uncrated equipment is handled.

 **WARNING Risk of damage to equipment.**

The crate is not designed to stand the force from hoist slings pressing on the top of the crate.

Always use a forklift to lift and transport the crated equipment.

 **WARNING Risk of personal injury.**

Never work under hanging load.

 **WARNING Risk of personal injury.**

Always use a forklift approved for the load and in accordance with local regulations.

Labels, symbols, and warning placards are located on the external surfaces of the crates and outline the handling principles which must be observed.

- Never leave a hanging load unattended.
- When the equipment, crated or uncrated, is assembled with the delivered pallet it must be lifted using a forklift.
- Plan the lifting and the transportation thoroughly.
- Define and seal off the risk areas for lifting and transport of the crated or uncrated equipment.
- Always perform a risk assessment of the risk area and transport ways before lifting and transporting the crated or the uncrated equipment.
- The crates should not be subjected to sudden shocks or movement. The crates are not load bearing and must not be stacked or have other items placed on them.
- The crates should be kept in the indicated upright position.
- Lift the crates as instructed. Lift only enough to clear the floor.
- Lift and transport the load slowly and gently.
- Crated equipment must be lifted in the pallet using a forklift.
- The length of the forklift forks should be equal to, or longer than, the depth of the pallet.
- Make sure that the crate remains stable on the lifting equipment.
- Move the crate to its destination.
- Lower the crate gently to the floor, leaving enough room around it for easy access to all sides.

- Make sure that the crate is firmly supported. Place blocks or plates under it if required.
- The centre of gravity must always be between the forklifts forks.

Labels that will indicate if the crates have been tipped over or exposed to extremes of humidity can be put on the crates or the equipment.

When the equipment is crated it must be lifted in the delivered pallet using a forklift.

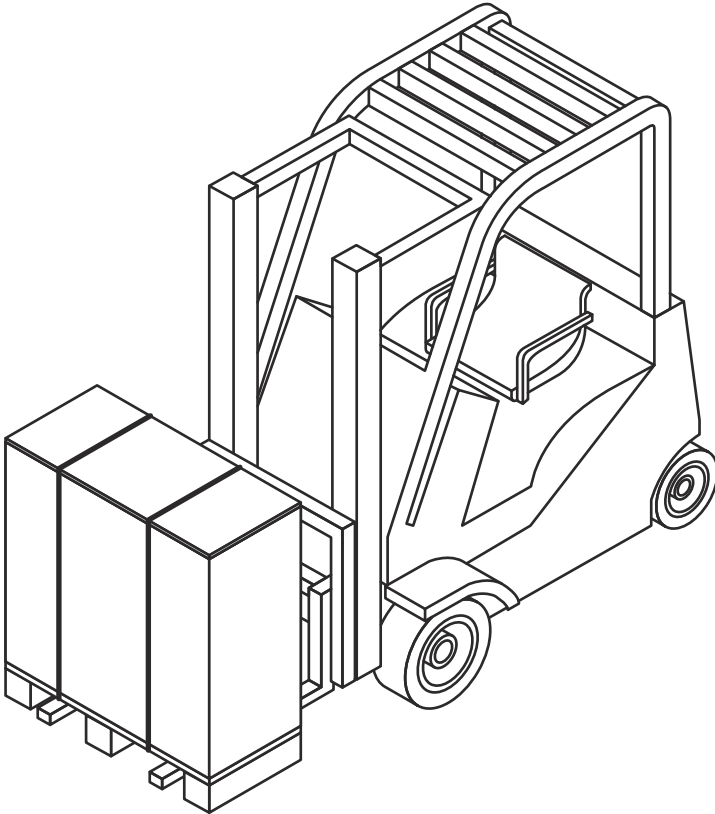

Uncrate the equipment according to Section [Unpacking the crate](#).

It is recommended to let the equipment remain assembled with the pallet and handle it using a forklift until it is time to install it.

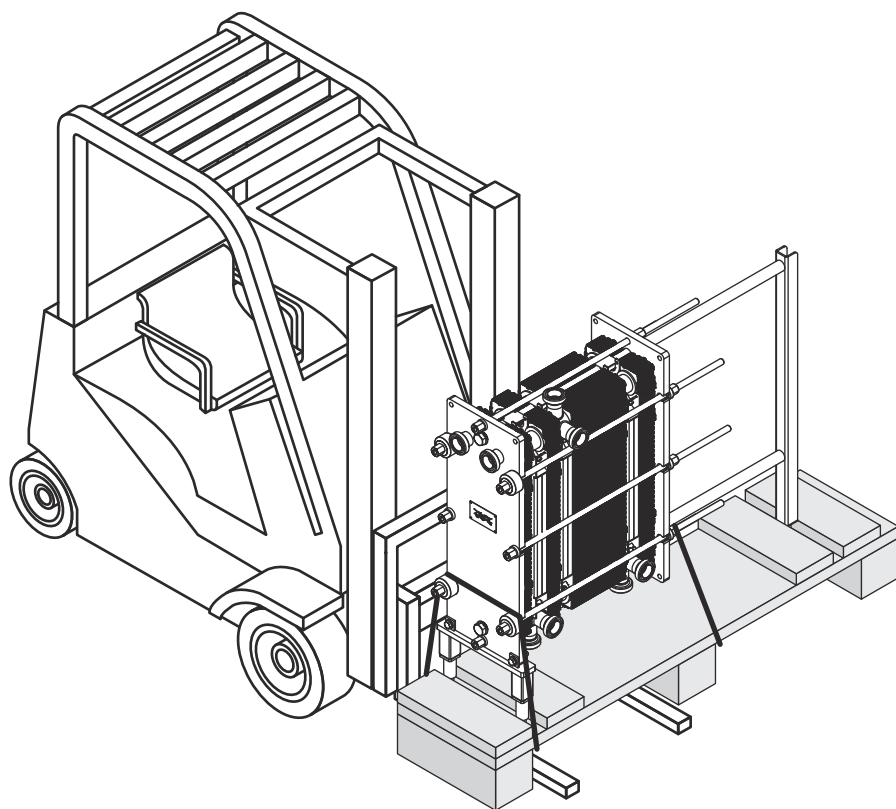
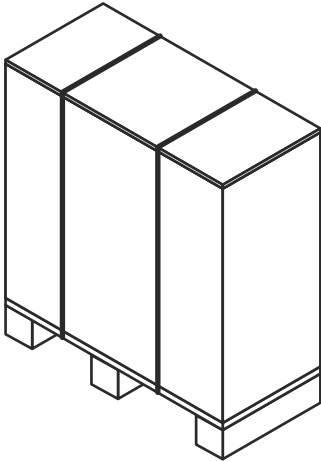

Figure 1: The illustration shows an example of equipment.

4.5 Unpacking the crate

Follow the procedure for the corresponding type of crate::

- Manufactured sides — See Procedure [Manufactured sides - Open](#)
- Flip box — See Procedure [Flip box - Open](#)
- Crafted sides — See Procedure [Crafted sides - Open](#)



Unpacking area

The minimum unpacking area must be at least twice the size of the largest crate.

When the crate is removed but the equipment is still assembled with the pallet, remove any loose parts or smaller parts assembled with the pallet.

Equipment can be assembled with the pallet with plastic bands or with screws. Plastic bands are cut off. Screws are removed.

4.5.1 Manufactured sides — Open

 **WARNING** Risk of personal injury.

The equipment or loose objects can fall. Plastic straps may snap when cut off. There can be sharp edges, splinters, and nails on the crate and the equipment.

Wear personal protective equipment when handling the equipment during unpacking and installation. Handle the equipment with precaution. See Section *Personal protective equipment* in Chapter *Safety*.

- 1 Cut the plastic bands off and remove the top of the crate.

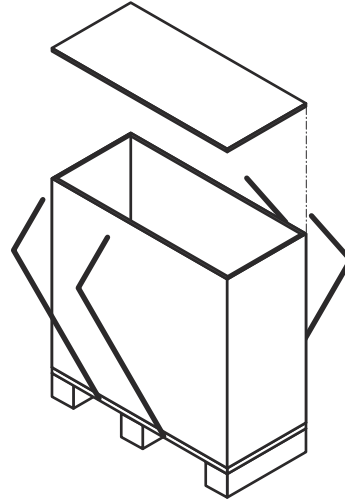

- 2 Disassemble the sides by removing the screws or the nails.

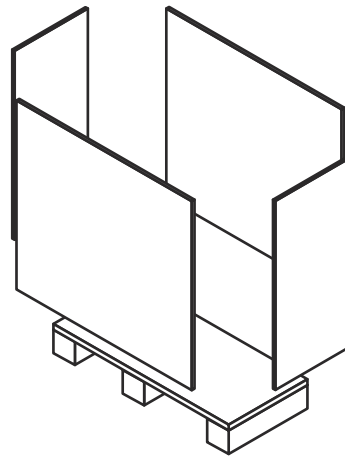

4.5.2 Flip box — Open

 **WARNING** Risk of personal injury.

The equipment or loose objects can fall. Plastic straps may snap when cut off. There can be sharp edges, splinters, and nails on the crate and the equipment.

Wear personal protective equipment when handling the equipment during unpacking and installation. Handle the equipment with precaution. See Section [Personal protective equipment](#) in Chapter [Safety](#).

- 1 Cut the plastic bands off and remove the top of the crate.

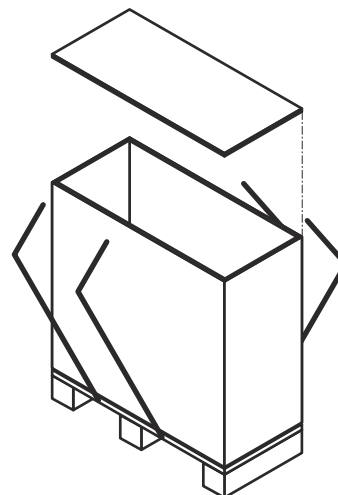

- 2 Lift the flipbox up and remove it from the pallet.

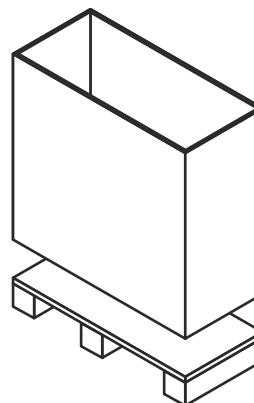

4.5.3 Crafted sides — Open

⚠ WARNING Risk of personal injury.

The equipment or loose objects can fall. Plastic straps may snap when cut off. There can be sharp edges, splinters, and nails on the crate and the equipment.

Wear personal protective equipment when handling the equipment during unpacking and installation. Handle the equipment with precaution. See Section *Personal protective equipment* in Chapter *Safety*.

A crate with crafted sides and top is assembled with boards.

- 1 Cut off the plastic bands and remove them.

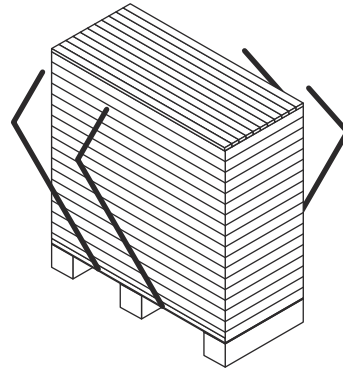

- 2 Start with the top of the crate and remove one board at a time.

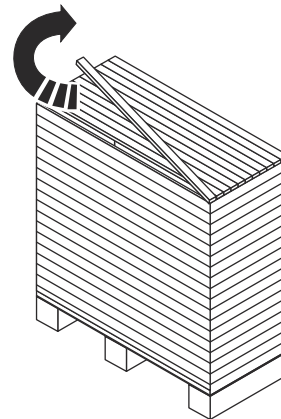

- 3 When the boards on the top are completely removed continue with the sides.

4.5.4 Inspection after uncrating

When the equipment is placed in its intended location, always perform the inspections listed below:

- Check the A measure (the distance between the inside of the frame plate and the inside of the pressure plate). The A measure can be found on the plate heat exchanger drawing as well as the number of plates.
- Make sure that all bolts are properly tightened.
- Make sure that the feet are properly tightened.

 **NOTE**

Some equipment is delivered with the stands disassembled.

- Check that connection piping can be removed to perform service.
- Make sure that there is enough space to remove plates on one side of the plate heat exchanger.

4.6 Lifting the equipment

It is recommended to engage the services of a rigging company to take care of all handling related matters until the equipment is in the position where it will be installed.

The safety information in this section is valid for all the lifting instructions described for different lifting equipment. Always read this section and take the safety messages in consideration before proceeding to the lifting instruction corresponding to your plate heat exchanger.

 **WARNING Risk of personal injury.**

Equipment is heavy with a centre of gravity placed high.

Lifting and transport of the crated and uncrated equipment must be carried out by skilled persons. See Section [Prior knowledge](#) in Chapter [Introduction](#).

 **WARNING Risk of personal injury.**

The equipment or loose objects can fall. Plastic straps may snap when cut off. There can be sharp edges, splinters, and nails on the crate and the equipment.

Wear personal protective equipment when handling the equipment during unpacking and installation. Handle the equipment with precaution. See Section [Personal protective equipment](#) in Chapter [Safety](#).

 **WARNING Risk of personal injury.**

Never work under hanging load.

 **WARNING Risk of personal injury.**

Never work alone during lifting and handling of the crated or uncrated equipment.

 **WARNING Risk of damage to equipment.**

For hoist slings or for lifting devices always use the attachment points marked with red rings in the illustrations. Use of other attachment points or hoist slings load directions than those described are not allowed. If the plate heat exchanger is not supplied with lifting devices from Alfa Laval, the corresponding equipment must be selected and the same attachment points must be used. The authorized personnel have full responsibility for selecting components and procedures in a safe and correct way. Always be careful during the lifting procedure to avoid damage to the equipment.

 **WARNING Risk of damage to equipment.**

Never lift by the connections or the stud bolts around them.

The authorized personnel are always responsible for the safety, correct selection of lifting equipment and execution of the lifting and raising procedures. Use undamaged hoist slings approved for the weight of the plate heat exchanger. Use the lifting points as illustrated in each section. If the equipment has lifting equipment assembled, these must be used.

If otherwise not stated, use two hoist slings (1) and (2) and make sure that the lifting angle (α) is between 45° and 90°.

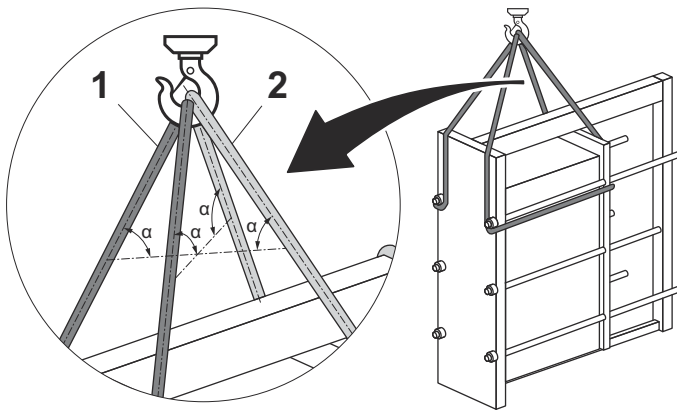

Figure 2: The illustration shows the threading of the hoist slings on an example of equipment.

Before loosening the equipment from the pallet, secure the equipment from falling using hoist slings.

NOTE

Do not lift up the equipment and the pallet. Only stretch the hoist slings so the equipment will not fall.

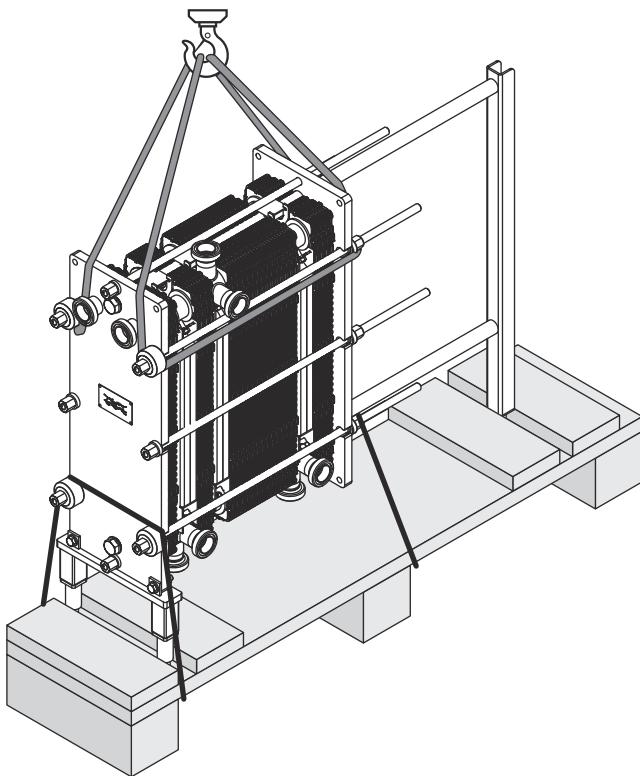

Figure 3: The illustration shows an example of equipment.

Remove any attachment that assembles the equipment with the pallet.

Gently lift up the equipment and make sure that it releases from the pallet.

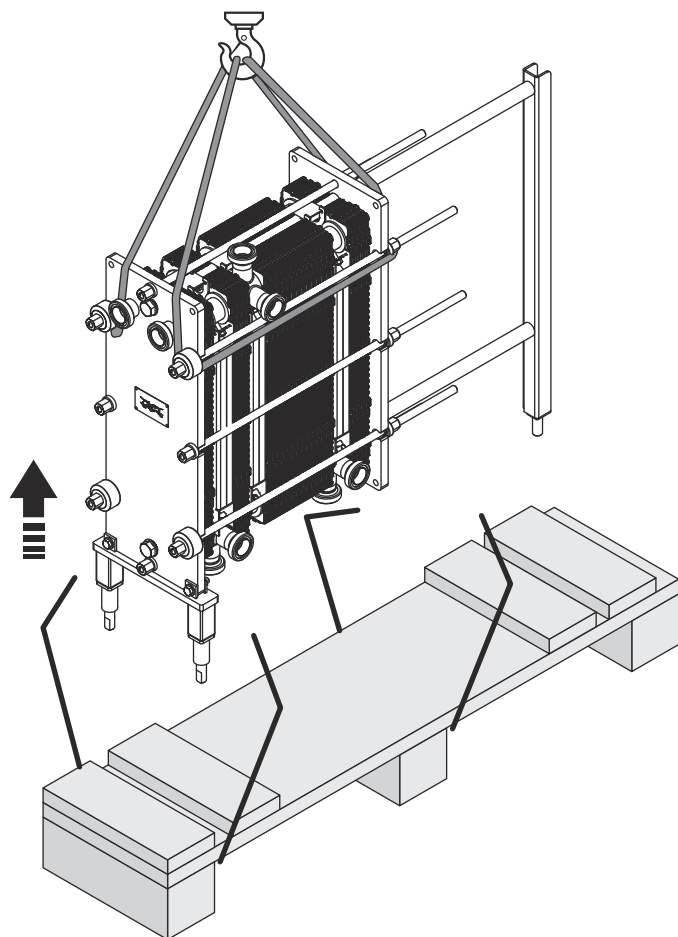
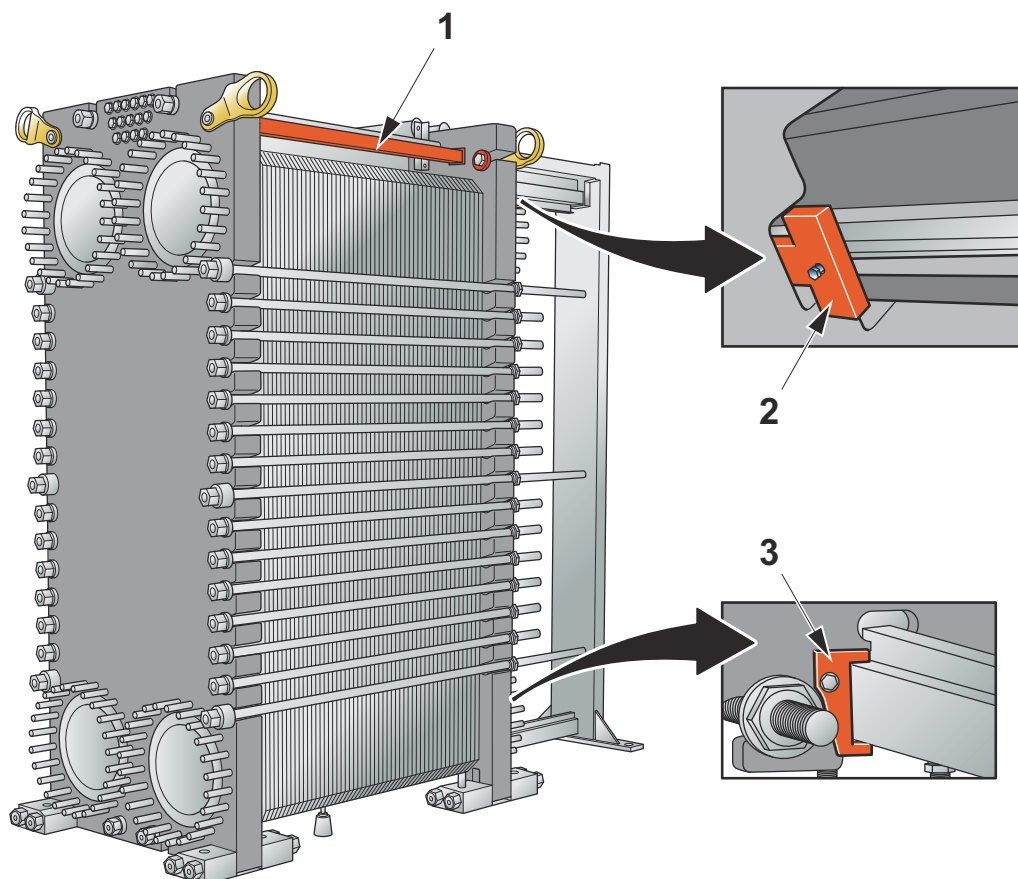

Figure 4: The illustration shows an example of equipment.

4.6.1 Securing devices

If the plate heat exchanger has lifting and securing devices (1), (2), and (3) they must not be removed before installation.. It is not allowed to use any of the securing devices for lifting. When the installation is complete the lifting and securing devices should be removed before start-up of the plate heat exchanger. The lifting and securing devices can be saved for future use if the plate heat exchanger should be moved.



1. Fasten the locking device securely between the frame plate and the pressure plate.
2. Fasten the locking bracket to secure the pressure plate to the carrying bar.
3. Fasten the locking bracket to secure the pressure plate to the guiding bar.

4.6.2 Lifting using lifting device

This section is only valid when lifting devices are used.

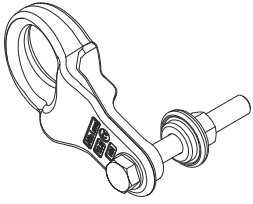

WARNING Risk of damage to equipment.

If there are transport securing equipment installed do not use these as lifting points. Always use the lifting devices as lifting points.

NOTE

The equipment is delivered with the lifting devices assembled. You can let them remain on the equipment after installation.

If the equipment is assembled with the delivered pallet, it must be lifted using a forklift. Follow the instructions in Section [Lifting and transportation](#).

If the equipment is disassembled from the delivered pallet, it must be lifted using hoist slings. Follow the instructions in Section [Lifting the equipment](#).

- 1 Check that the lifting devices are properly assembled. Tighten the screws if necessary.
- 2 Assemble hoist slings to the lifting devices. Use two or four hoist slings depending on the weight of the plate heat exchanger.

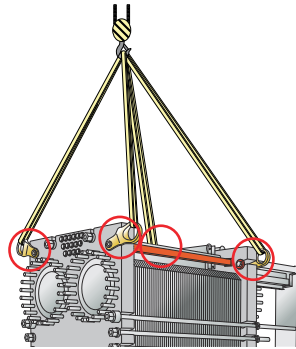

- 3 Slowly lift the equipment just to clear the ground.
- 4 Make sure that the equipment is hanging levelled.

4.6.3 Lifting using lifting wire

This section is only valid when lifting wire is used.

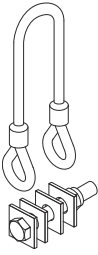

NOTE

The equipment is delivered with the lifting wires assembled. You can let them remain on the equipment after installation.

The bending diameter of the wire loop D must be greater than six times the wire diameter. $D > 6d$.

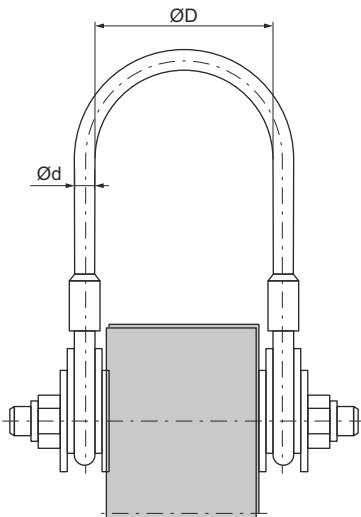

Figure 5: Lifting wire assembled with a frame plate.

If the equipment is assembled with the delivered pallet, it must be lifted using a forklift. Follow the instructions in Section [Lifting and transportation](#).

If the equipment is disassembled from the delivered pallet, it must be lifted using chain slings. Follow the instructions in Section [Lifting the equipment](#).

- 1 Check that the lifting wires are properly assembled. Tighten the screws if necessary.

4.6.4 Lifting using lifting eye bolts

This section is only valid when lifting eye bolts are used.

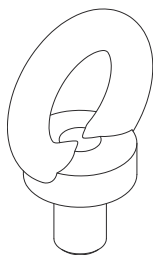

If the equipment is assembled with the delivered pallet, it must be lifted using a forklift. Follow the instructions in Section [Lifting and transportation](#).

If the equipment is disassembled from the delivered pallet, it must be lifted using hoist slings. Follow the instructions in Section [Lifting the equipment](#).

- 1 Make sure that the lifting equipment lifting point is placed in the centre of gravity area of the plate heat exchanger.
- 2 Use a chain sling and fit the lifting hooks or the lifting shackles to each of the four lifting eye bolts assembled with the plate heat exchanger.

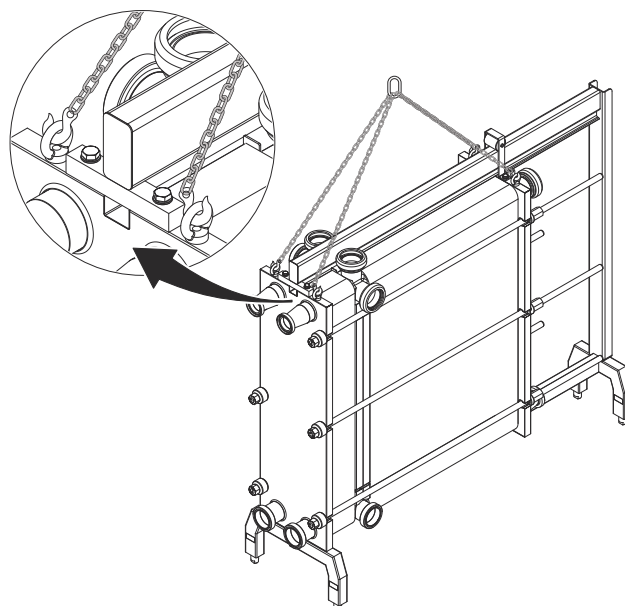

- 3 Slowly lift the equipment just to clear the ground.
- 4 Make sure that the equipment is hanging levelled.

4.6.5 Lifting using swivel eye bolt

This section is only valid when swivel eye bolts are used.

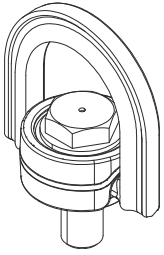

If the equipment is assembled with the delivered pallet, it must be lifted using a forklift. Follow the instructions in Section [Lifting and transportation](#).

If the equipment is disassembled from the delivered pallet, it must be lifted using hoist slings. Follow the instructions in Section [Lifting the equipment](#).

- 1 Make sure that the lifting equipment lifting point is placed in the centre of gravity area of the plate heat exchanger.
- 2 Thread one end of a hoist sling over the lifting equipment.
- 3 Thread the other end of the hoist sling through one of the swivel eye bolt pairs.

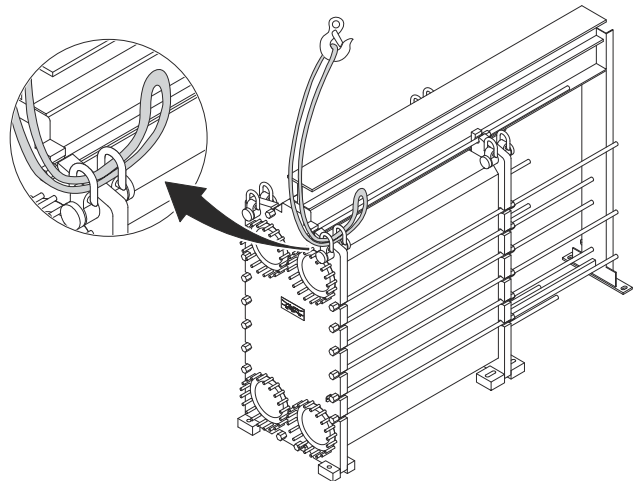

- 4 Thread also the second end of the hoist sling over the lifting equipment.

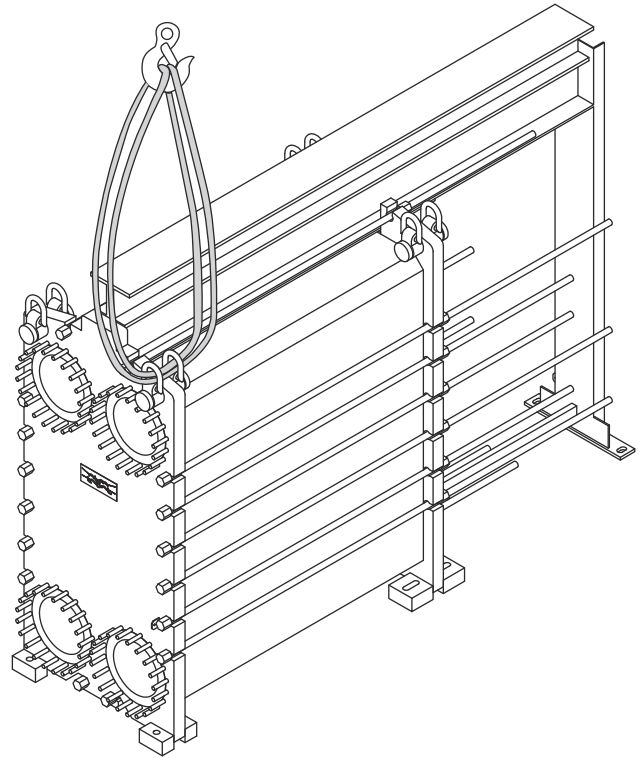

- 5 Repeat the procedure on the remaining swivel eye bolts.

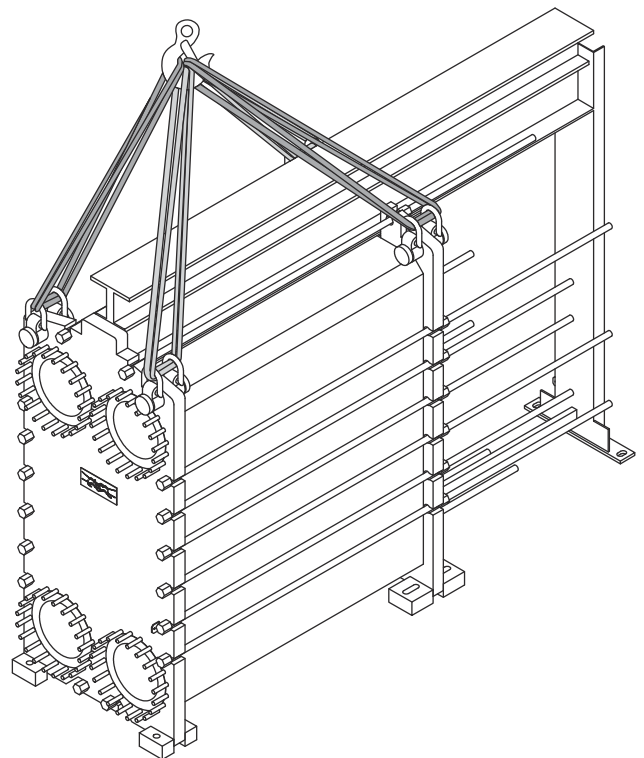

- 6 Slowly lift the equipment just to clear the ground.
- 7 Make sure that the equipment is hanging levelled.

4.6.6 Lifting using hoist slings

This section is only valid when hoist slings are used. There are two different ways of threading hoist slings, the first one described is the recommended one. If this method can not be used, follow the instructions for the alternative method.

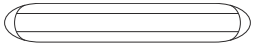

If the equipment is assembled with the delivered pallet, it must be lifted using a forklift. Follow the instructions in Section [Lifting and transportation](#).

If the equipment is disassembled from the delivered pallet, it must be lifted using hoist slings. Follow the instructions in Section [Lifting the equipment](#).

 **WARNING** Risk of personal injury

The equipment is heavy.

Use one or two hoist slings depending on the equipment weight.

- 1 If two hoist slings are used, thread them according to the illustration.

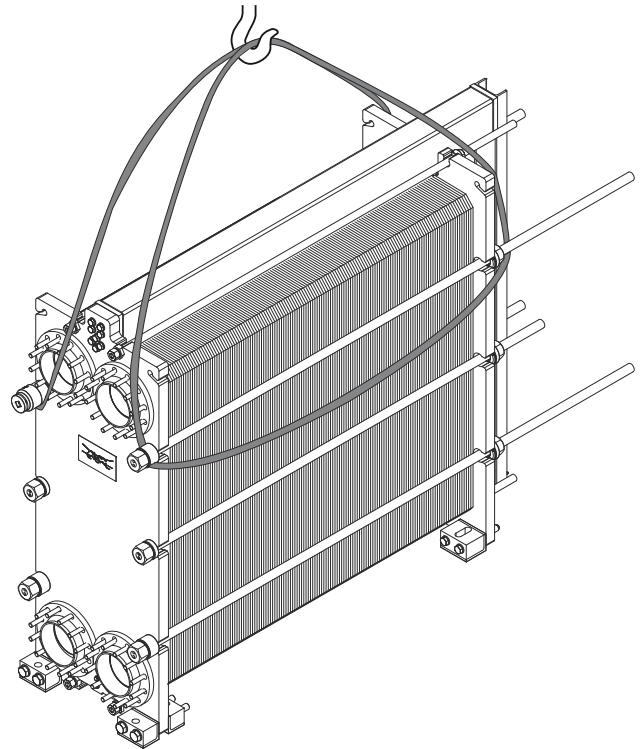

- 2 If one hoist sling is used, thread it according to the illustration.

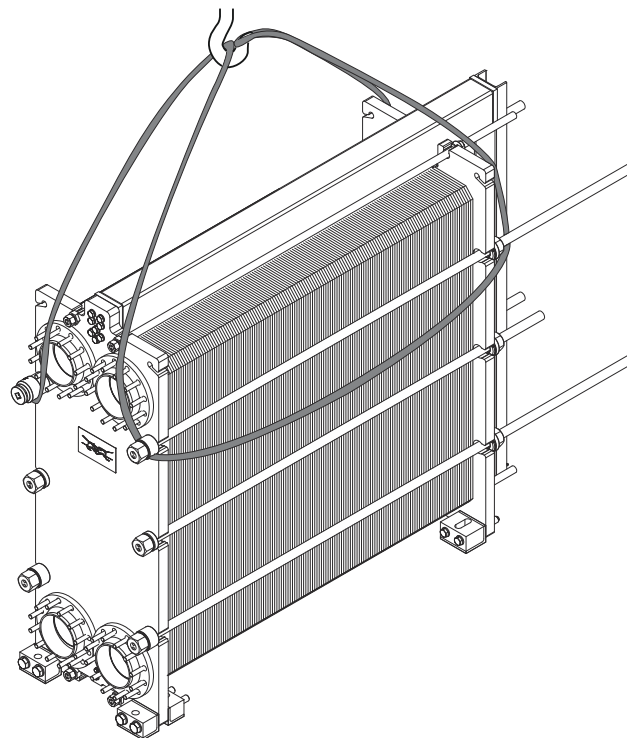

- 3 Slowly lift the equipment just to clear the ground.

- 4 Make sure that the equipment is hanging levelled.

5 **NOTE**

The method described in this and the following steps is an alternative method.

Put one hoist sling between the frame plate slots. Connect the hoist sling to the lifting equipment.

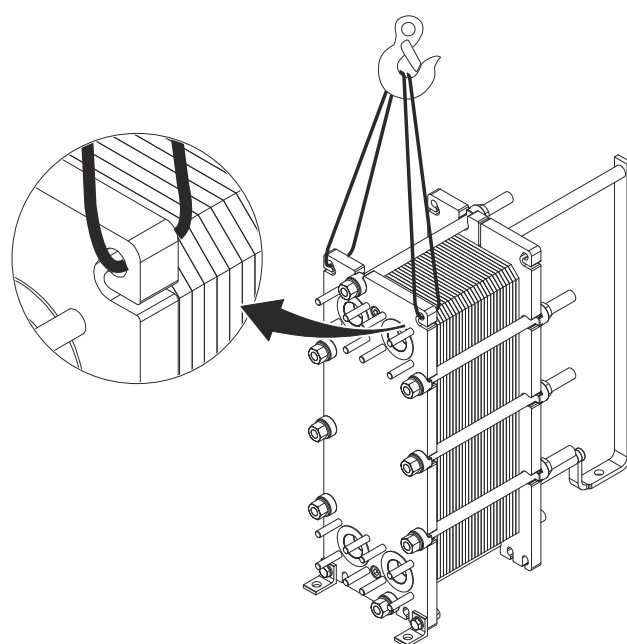

- 6 Put one hoist sling between the pressure plate slots. Connect the hoist sling to the lifting equipment.

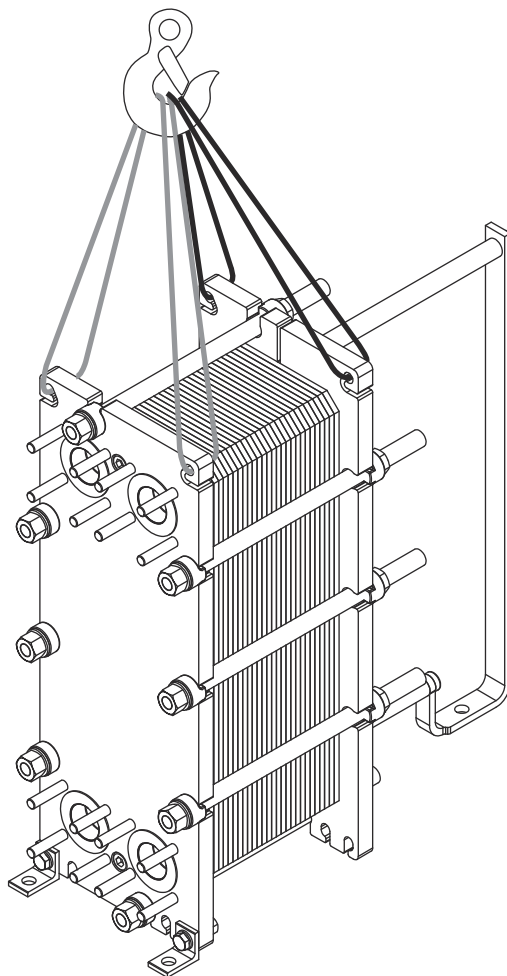

- 7 Slowly lift the equipment just to clear the ground.

- 8 Make sure that the equipment is hanging levelled.

4.7 Raising

4.7.1 Raising using lifting eye bolts

This instruction is valid when raising the plate heat exchanger after delivery from Alfa Laval. Only use lifting equipment approved for the weight of the plate heat exchanger.

CAUTION Risk of damage to equipment.

The hoist slings shall be long enough to be able to rotate the plate heat exchanger without obstruction. Consider especially the space for the support column. Always be careful during the raising procedure to avoid damage to the plate heat exchanger components.

- 1 Remove all the feet from the frame plate.

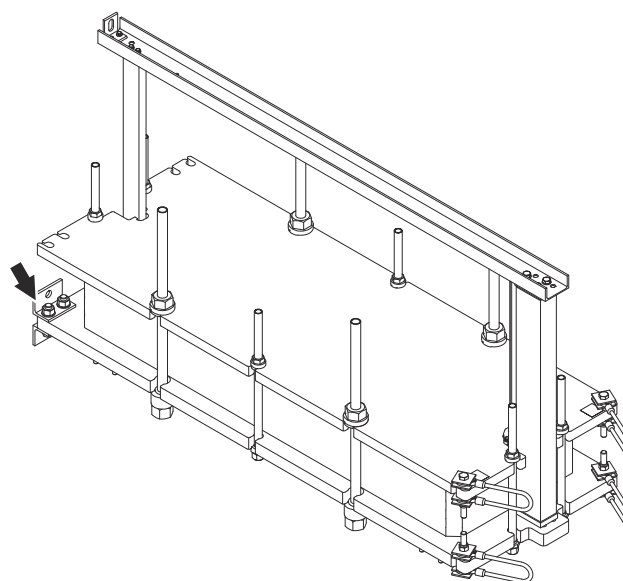

- 2 Place a wooden beam under the frame plate bottom edge.

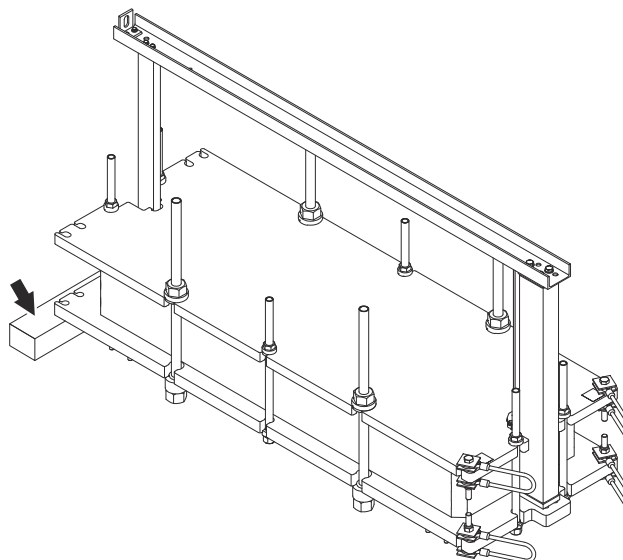

- 3 Remove the lifting wires from the pressure plate.

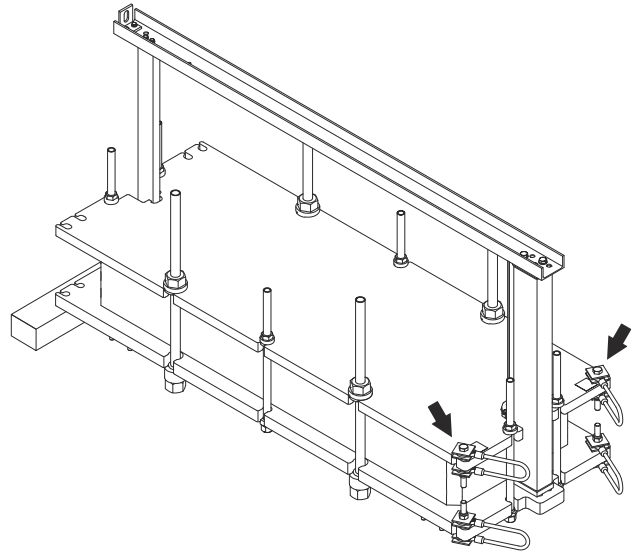

- 4 Assemble two lifting eye bolts to the pressure plate.

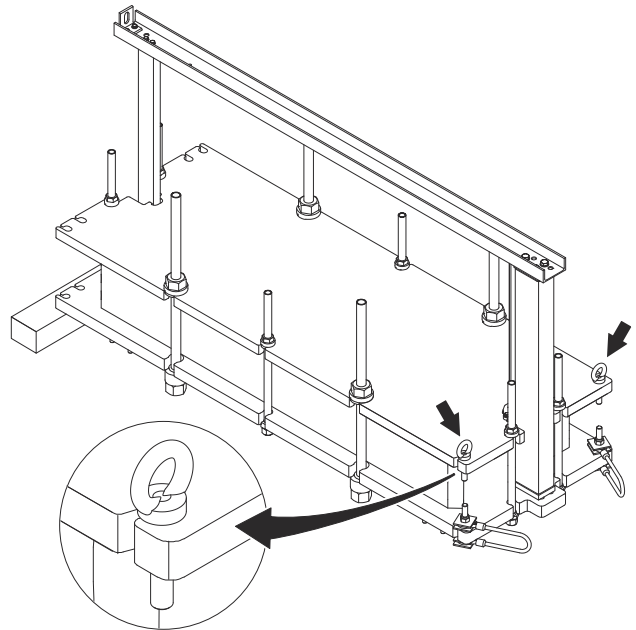

- 5 Fit one hoist sling in each lifting eye bolt.

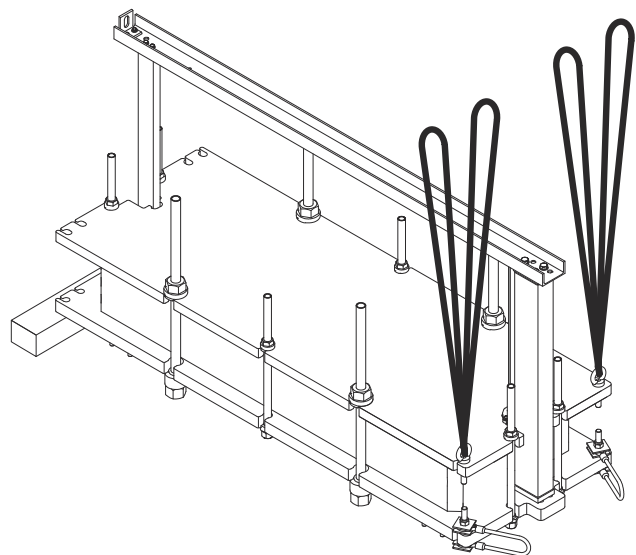

- 6 Attach the hoist slings to a lifting point.

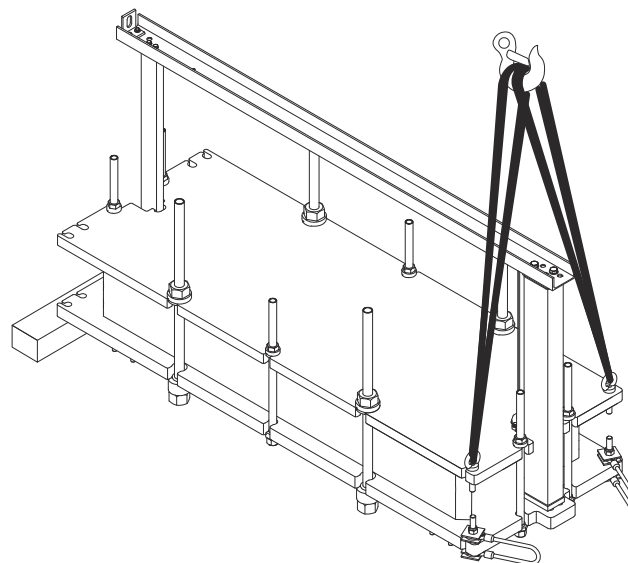

- 7 Carefully raise the plate heat exchanger. Pay special attention when passing the centre of gravity.

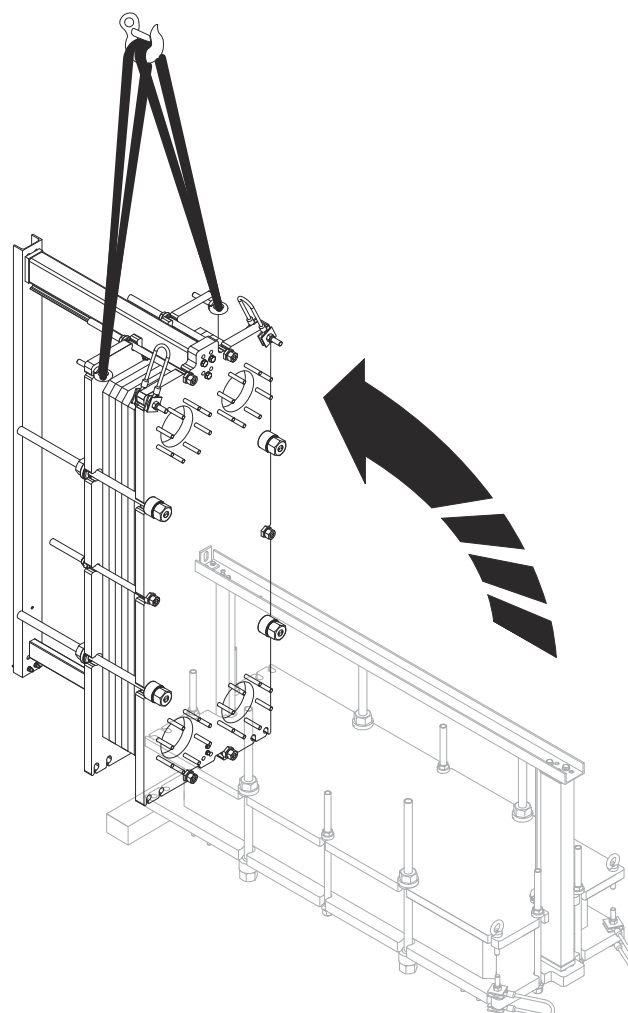

- 8 Remove the hoist slings.

- 9 Remove the lifting eye bolts.

- 10 Assemble the lifting wires back to the pressure plate.
 - 11 Gently lift the plate heat exchanger up a bit from the ground. Lift according to the Section [Lifting using lifting wire](#).
 - 12 Assemble the feet back to the frame plate.
 - 13 Remove the wooden beam.
 - 14 Lower the plate heat exchanger to the ground.
 - 15 Remove the lifting equipment.
-

The plate heat exchanger can now be handled according to the lifting instructions in this manual.

4.7.2 Raising using hoist slings on pressure plate

This instruction is valid when raising the plate heat exchanger after delivery from Alfa Laval. Only use a strap approved for the weight of the plate heat exchanger. Follow the principle of the instruction below.

CAUTION Risk of damage to equipment.

The hoist slings shall be long enough to be able to rotate the plate heat exchanger without obstruction. Consider especially the space for the support column. Always be careful during the raising procedure to avoid damage to the plate heat exchanger components.

- 1 Remove all the feet from the frame plate.

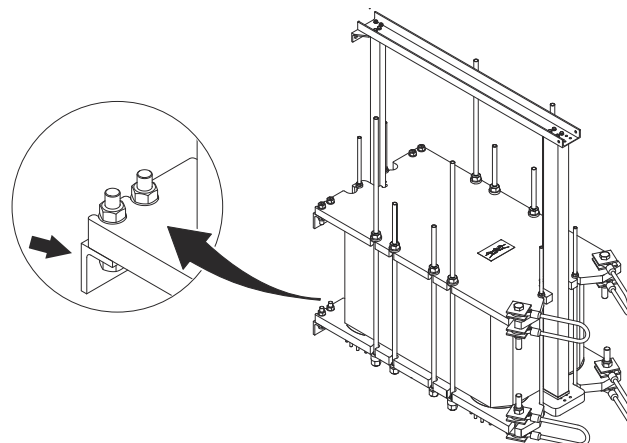

- 2 Remove the lifting wires from the pressure plate.

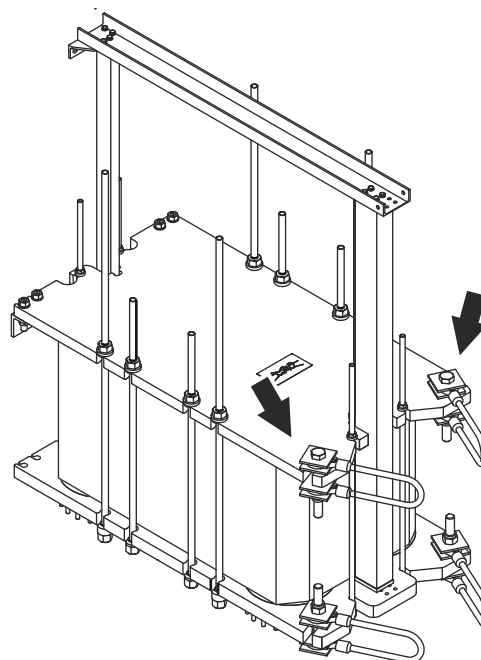

- 3 Place a wooden beam under the frame plate bottom edge.

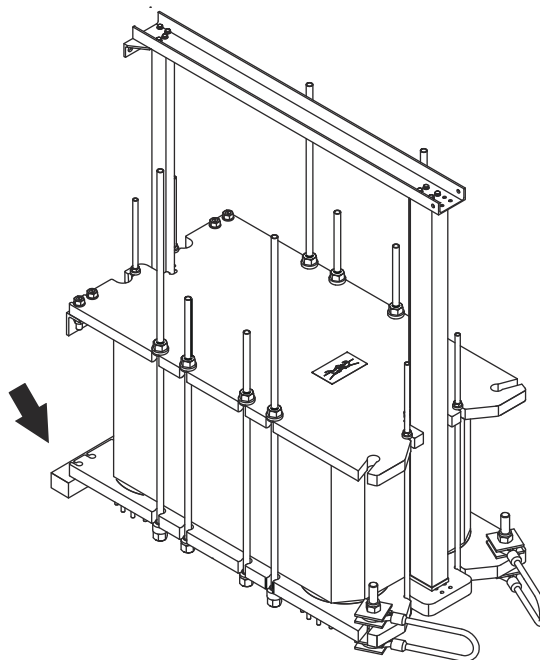

- 4 Thread a hoist sling through the pressure plate keyhole.

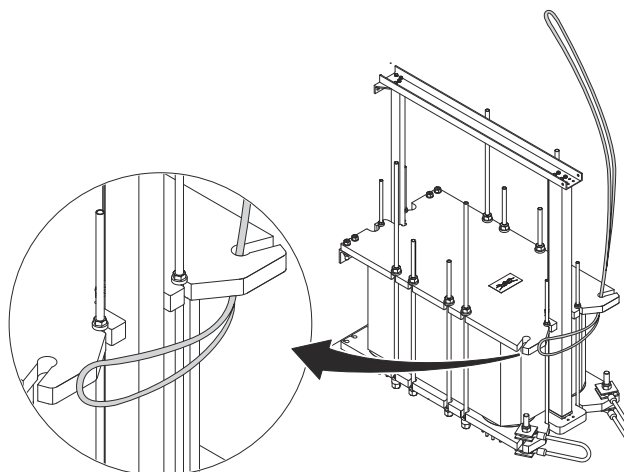

- 5 Pull the hoist sling further until you can put in the opposite side keyhole of the pressure plate.

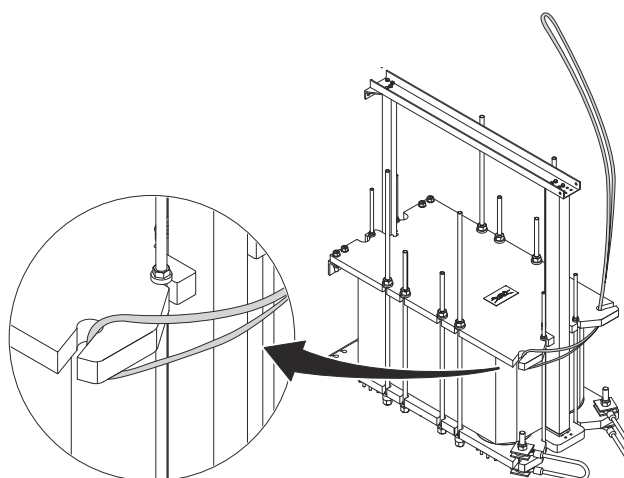

- 6 Thread a second hoist sling in the same way but starting from the opposite side.

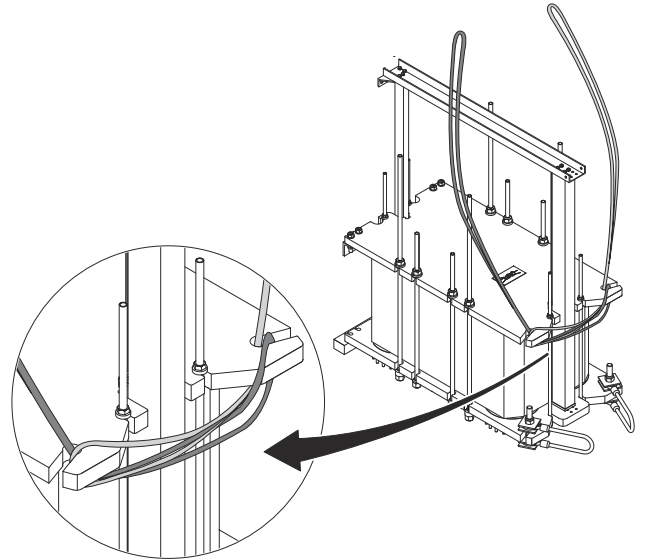

- 7 Stretch the hoist slings and make sure that both fits inside the keyholes.

- 8 Attach the hoist slings to a lifting point.

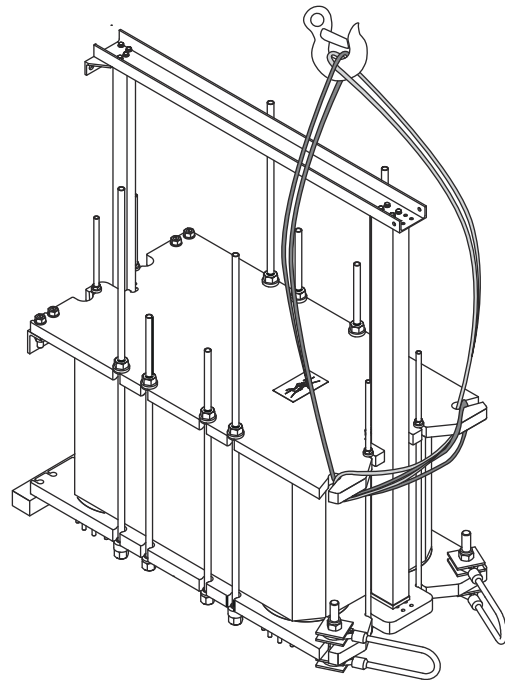

- 9 Carefully raise the plate heat exchanger. Pay special attention when passing the centre of gravity.

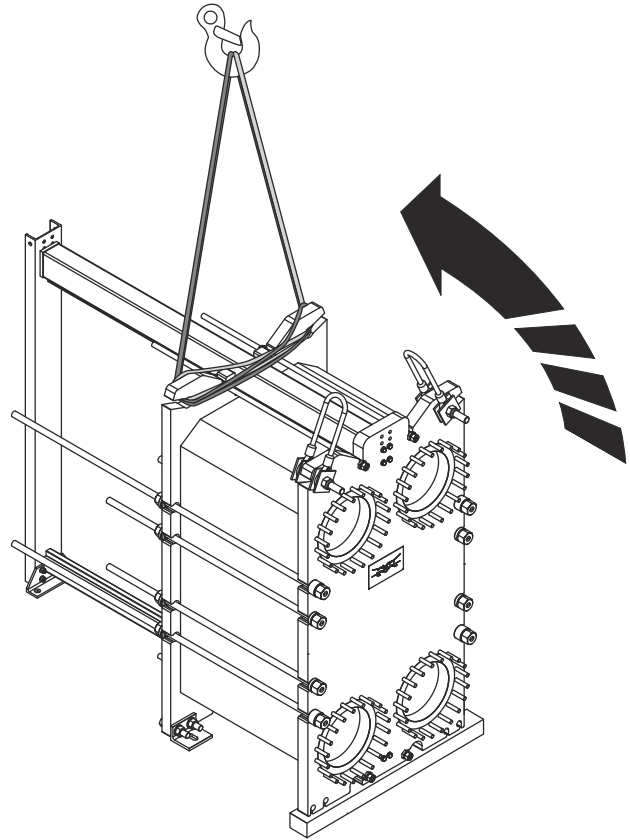

- 10 Remove the hoist slings.
- 11 Assemble the lifting wires back to the pressure plate.
- 12 Gently lift the plate heat exchanger up a bit from the ground. Lift according to the appropriate section in the Chapter *Lifting the equipment*.
- 13 Assemble the feet back to the frame plate.
- 14 Remove the wooden beam.
- 15 Lower the plate heat exchanger to the ground.
- 16 Remove the lifting equipment.

The plate heat exchanger can now be handled according to the lifting instructions in this manual.

4.7.3 Raising using hoist slings around the plate heat exchanger

This instruction is valid when raising the plate heat exchanger after delivery from Alfa Laval. Only use a strap approved for the weight of the plate heat exchanger. Follow the principle of the instruction below.

CAUTION Risk of damage to equipment.

The hoist slings shall be long enough to be able to rotate the plate heat exchanger without obstruction. Consider especially the space for the support column. Always be careful during the raising procedure to avoid damage to the plate heat exchanger components.

- 1 Place two timber beams on the floor.

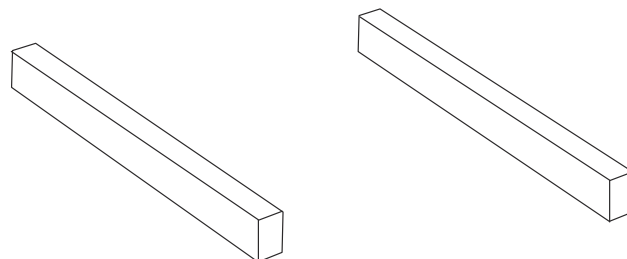

- 2 Lift the plate heat exchanger off the pallet using hoist slings.

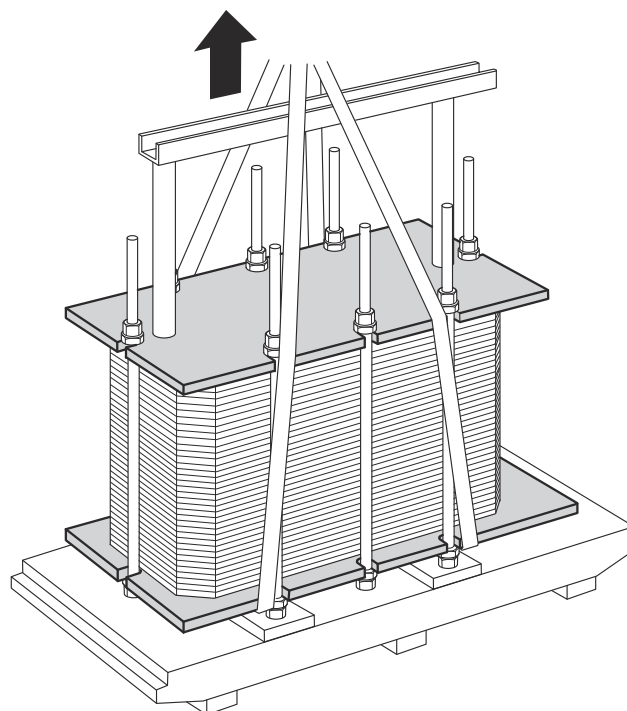

- 3 Place the plate heat exchanger on the timber beams.

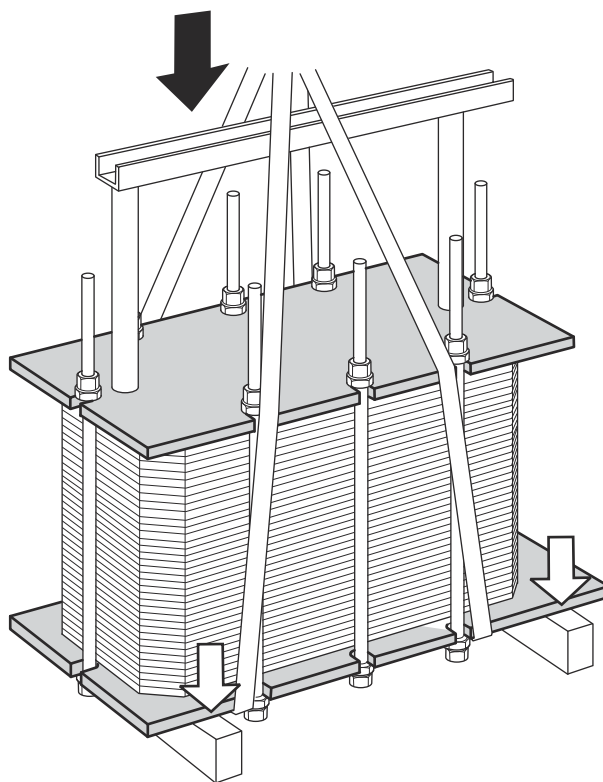

- 4 Place a hoist sling around one bolt on each side.

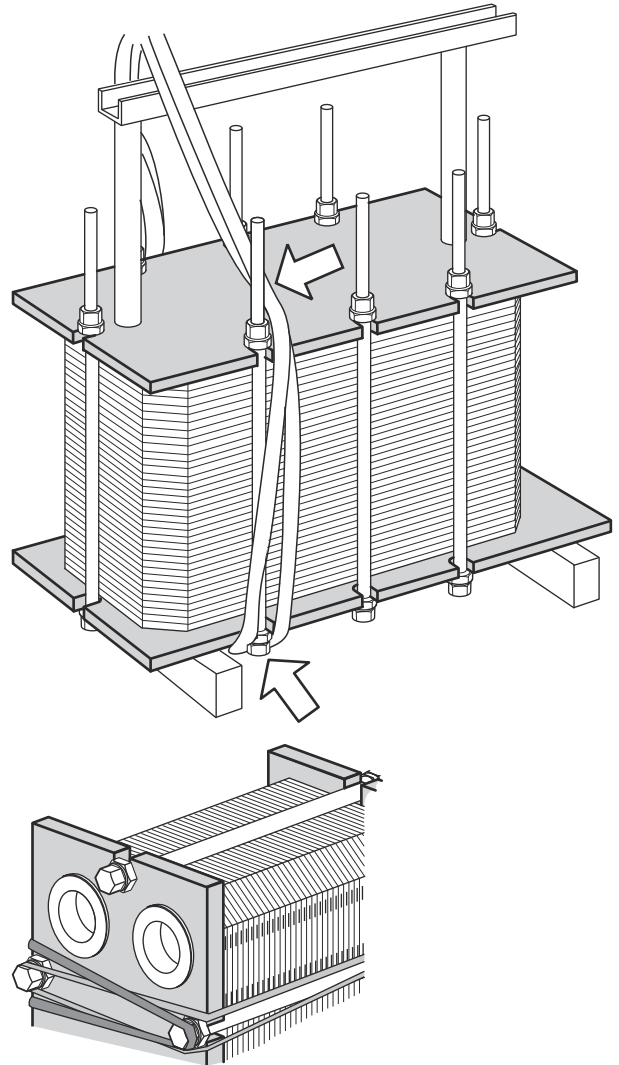

- 5 Lift the plate heat exchanger off the timber beam at one side.

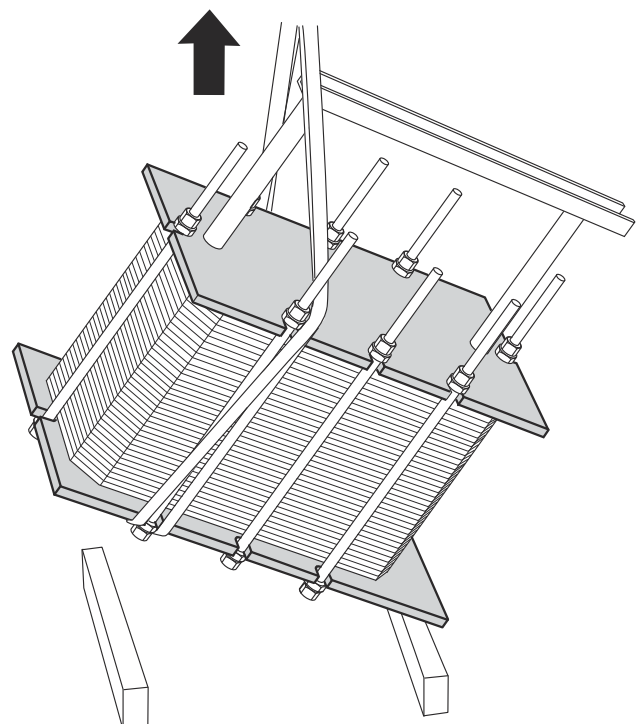

- 6 Carefully move the lifting equipment forward until the plate heat exchanger turns over to raised position. Pay special attention when passing the centre of gravity.

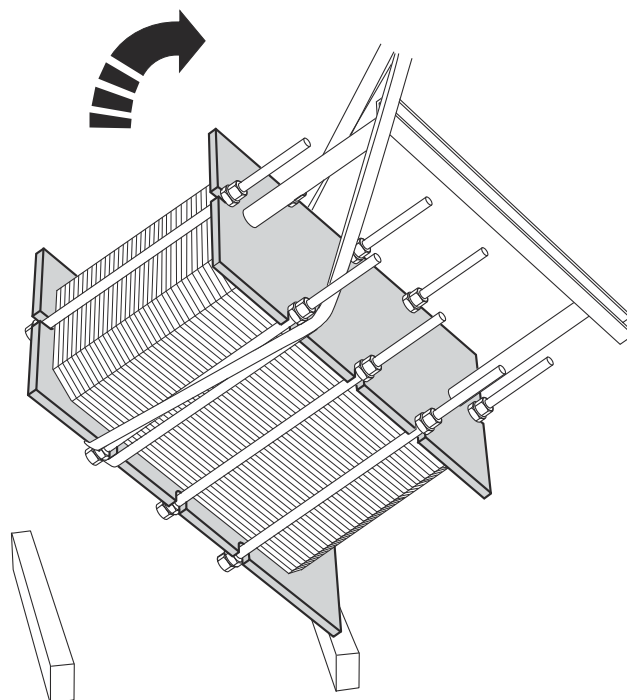

- 7 Lower the plate heat exchanger into a horizontal position and place it on the floor.

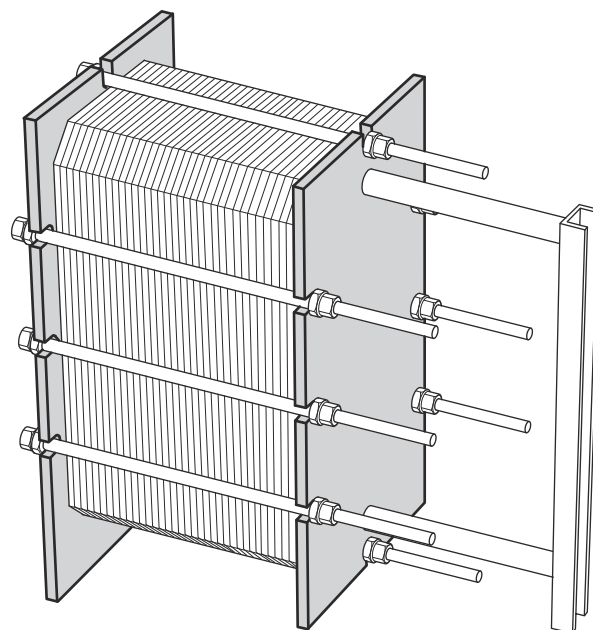

4.8 Assembly of feet

Some hygienic plate heat exchangers are delivered with the feet disassembled. Follow the instruction below.



WARNING Risk of personal injury.

The equipment is heavy.

Be careful when handling the equipment. Do not reach in under equipment that is not secured.

Never work under hanging load.

Always make safety arrangement to avoid crushing.

- 1 Cover plates are on delivery attached to the frame plates and support column in the positions where the feet shall be assembled.
- 2 Lift the equipment according to Section *Lifting the equipment* in the *installation Manual*.
- 3 To minimize the risk of personal injury in case the equipment should accidentally fall, place wooden beams under the equipment.
- 4 Remove the screws, the washers, and the nuts and then remove the cover plates.

- 5 Use the same screws, washers and nuts to assemble the feet on the plate heat exchanger according to the picture.

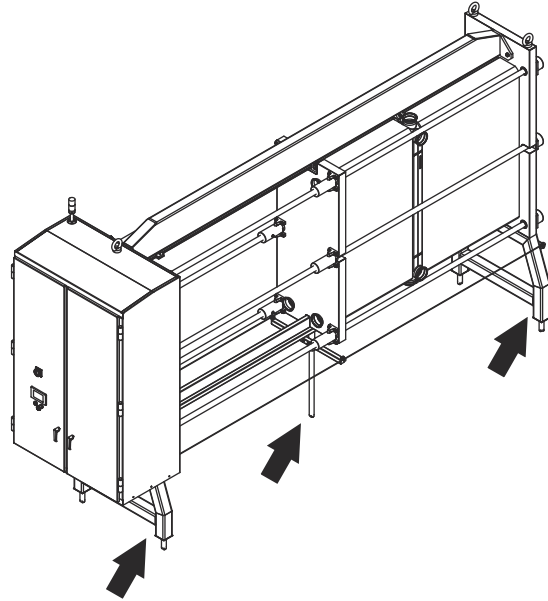
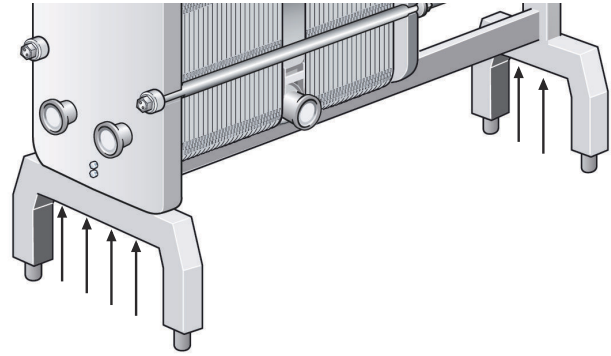

- 6 If the unit has two stabilising bars, assemble them according to the picture.

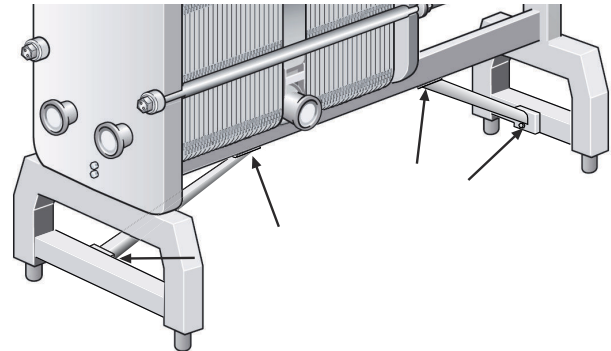

4.9 Transport covers

There are different kinds of transport covers:

- transport covers that are pushed in place at a port hole
- transport covers that are assembled to the stud bolts using nuts

Transport covers that are pushed in place can be manually removed.

To remove a transport cover assembled to the stud bolts using nuts follow the instruction in the section *Remove transport cover* below.

A plate heat exchanger can be delivered with the plate package filled with nitrogen gas. In this case the transport cover has a gasket as a seal between the transport cover and the port hole. This gasket is **not** designed for operational pressures or process fluids, it must be removed and scrapped. Never re-use the gasket in any connection.

The transport covers should remain on the plate heat exchanger until it is put on its intended place. Before installation of connections and pipes the transport covers must be removed and scrapped.

Remove transport cover

1. Remove the nuts (1) from the stud bolts (4).
2. Remove the transport cover (2).
3. Remove the gasket (3).
4. Scrap the transport cover and the gasket.
5. Repeat on all connections with transport cover.

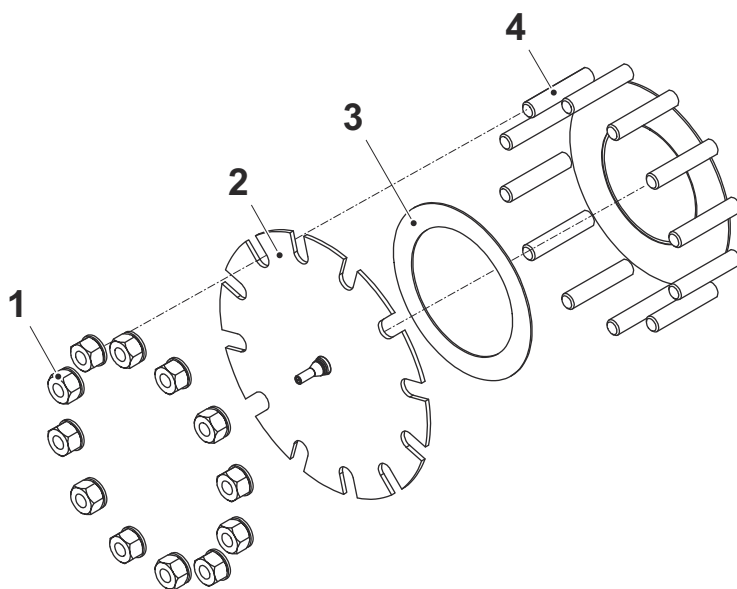

4.10 Inspection before installation

When the equipment is placed in its intended location, always perform the inspections listed below:

- Check the A measure (the distance between the inside of the frame plate and the inside of the pressure plate). The A measure can be found on the plate heat exchanger drawing as well as the number of plates. For instructions regarding the A measure, see the maintenance manual.
- Make sure that all bolts are properly tightened. For instructions how to tighten the bolts, see the maintenance manual.
- Make sure that the stands and feet are properly tightened.
- Check that connection piping can be removed to perform service.
- Make sure that there is enough space to remove plates on one side of the plate heat exchanger.
- It is strongly recommended to perform a hydrostatic leakage test to confirm the internal and external sealing function of the plate heat exchanger. See the maintenance manual for further information.

4.11 Start-up

During the start-up, check that there are no visible leakages from the plate pack, valves or piping system.

 **CAUTION Risk of damage to equipment.**

Before pressurizing the plate heat exchanger, it is important to ensure that the temperature of the plate heat exchanger is within the temperature range as stated in the plate heat exchanger drawing or on the type plate.

 **CAUTION Risk of leakage.**

If the temperature of the plate heat exchanger is below the minimum temperature for the gaskets prior to the service, it is recommended to heat the plate heat exchanger above this limit to avoid cold leakage.

 **CAUTION Risk of damage to equipment.**

If several pumps are included in the system, make sure you know which one should be activated first.

Centrifugal pumps must be started with valves closed and the valves must be operated as smoothly as possible.

Do not run pumps temporarily empty on the suction side.

 **CAUTION Risk of damage to equipment.**

Adjustments of flow rates should be made slowly in order to avoid the risk of pressure surge (water hammer).

Water hammer is a short lasting pressure peak that can appear during the start-up or shut-down of a system, causing liquids to travel along a pipe as a wave at the speed of sound. This can cause considerable damage to the equipment.

 **CAUTION Risk of damage to equipment.**

Avoid rapid temperature changes in the plate heat exchanger.

Slowly increase the media temperature, preferably in steps of 10 °C each sixth minutes. To reach a media temperature of 100 °C should take at least one hour.

 **CAUTION Risk of damage to equipment.**

Charging liquid ammonia into a refrigeration circuit under vacuum will result in low temperatures. Such temperature levels might be lower than any elastomeric materials can seal against.

In applications where the field side is used for a two-phase refrigerant like cascade CO₂ / NH₃ applications, it is very important to fill the two-phase refrigerant in gas phase. This to avoid temperature shocks for the gaskets and to avoid temporary leakages due to the natural fact that the metal is shrinking very fast.

NOTE Risk of damage to equipment.

Charging liquid ammonia into a refrigeration circuit under vacuum will result in low temperatures.

Such temperature levels might be lower than any elastomeric materials can seal against. In applications where the field side is used for a two-phase refrigerant, for example cascade CO₂ / NH₃ applications, it is very important to fill the two-phase refrigerant in gas phase. This to avoid temperature shocks for the gaskets and to avoid temporary leakages due to the natural fact that the metal is shrinking very fast.

- 1 Check that all the tightening bolts are firmly tightened and that the A measure is correct. See the plate heat exchanger drawing.

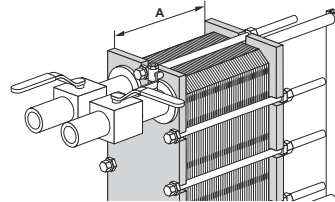

- 2 Check that the valve is closed between the pump and the unit controlling the system flow rate to avoid pressure surge.

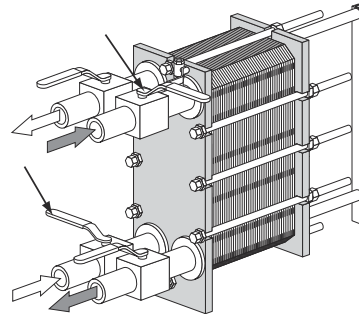

- 3 If there is a vent valve installed at the exit, make sure it is fully open.

- 4 Increase the flow rate slowly.

- 5 Open the air vent and start the pump.

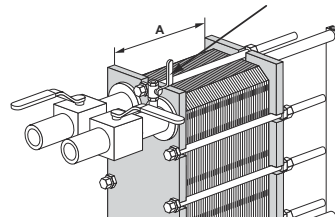

-
- 6 Open the valve slowly.

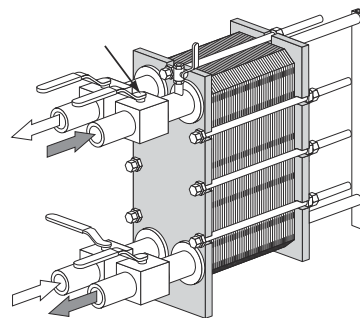

-
- 7 When all the air is expelled, close the air vent.

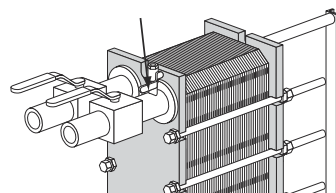

-
- 8 Repeat the procedure for the second media.
-

4.11.1 Connections

Certain units are equipped with a special loose flange with a rectangular appearance. The intention is to use a pipe collar or stub end to which the customer pipe is welded and assembled to the plate heat exchanger using the special loose flange.

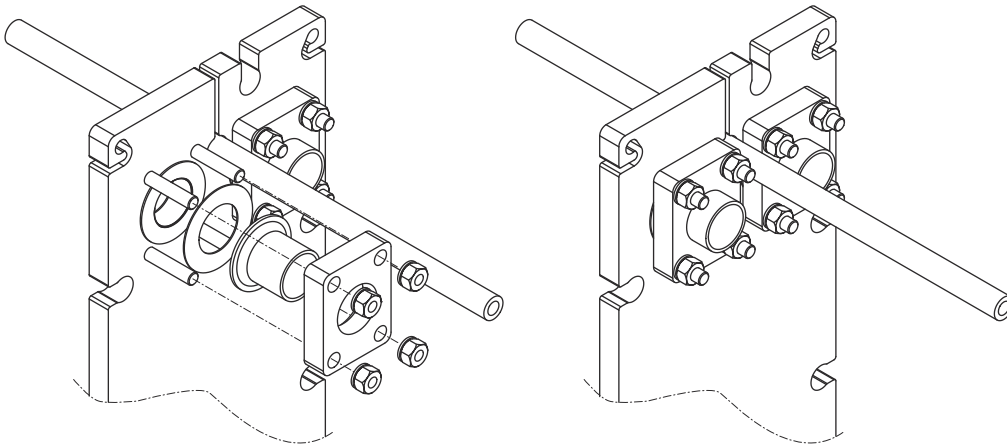

Threaded pipe connection

⚠ WARNING Risk of damage to equipment.

Risk of damage to equipment.

Turning of the connections will damage the gaskets on the end plate and cause leakage.

Secure the pipe connections on the plate heat exchanger from rotating using for example a monkey wrench.

Make sure the pipe connections are securely held to prevent rotation to avoid damaging the gaskets.

