

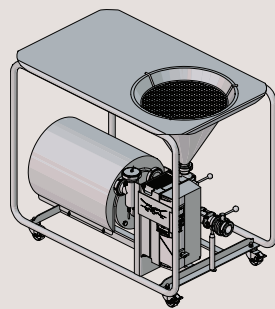

Instruction Manual

Alfa Laval Hybrid Powder Mixer HPM M15 & HPM S15



HPM M15 and S15

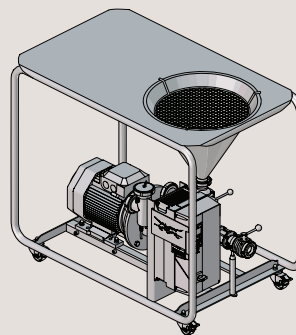
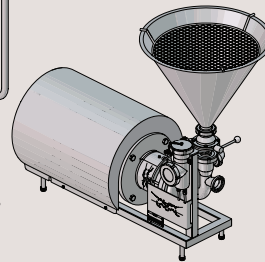

HPM M15 and S15 (US version)

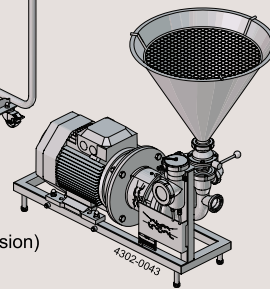

First published: 2013-11

The information herein is correct at the time of issue but may be subject to change without prior notice

1. Declarations of Conformity	5
2. Product programme	7
2.1. Standard	7
3. Safety	8
3.1. General hazards	8
3.2. Intended use of the machine	8
3.3. Protective measures	8
3.4. Transportation	8
4. Specific safety instructions and the symbols used	9
4.1. Important information	9
4.2. General safety instructions	9
4.3. Basic safety measures during normal operation	10
4.4. Basic safety measures during maintenance, repair and cleaning	11
4.5. Working on the electrical equipment	12
4.6. Working on the flush tank	12
4.7. Observe the environmental protection instructions	12
4.8. Residual risks	13
5. Functioning	14
5.1. Function description	14
5.2. Construction of the AL HPM	15
6. Setting up and installation	18
6.1. Unpacking and setting up	18
6.2. Connecting the product pipes	18
6.3. Flush tank and axial face seal	19
6.4. Power supply	19
7. Commissioning	20
7.1. Connecting the AL HPM to a mixing tank	20
7.2. Brief test	21
7.3. Information on working with products	22
7.4. Powering up the machine	22
8. Cleaning and maintenance	23
8.1. Cleaning (CIP)	23
8.2. The axial face seal	23
8.3. C-Ball Valve	23
8.4. Rotor/Stator	23
8.5. Barrier fluid installation	23
8.6. Drive	23
9. Installation and removal	24
9.1. Rotor/Stator	24
9.2. Installing the drive	24
10. Technical data	25
10.1. Hybrid Powder Mixer HPM S15 and M15	25
11. Operational data	26
11.1. Technical data	26

Table of contents

The information herein is correct at the time of issue but may be subject to change without prior notice

11.2. Dimensions/weight	26
12. HPM M15 & HPM S15, spare parts and drawings	27
12.1. HPM-M15 - Hybrid Powder Mixer, complete	27
12.2. HPM-M15 - Butterfly Valve	29
12.3. HPM-M15 - In-line Sight Glass	31
12.4. HPM-S15 - Hybrid Powder Mixer, complete	33
12.5. HPM-M15 & HPM-S15 - Flush Tank	35
12.6. HPM-M15 & HPM-S15 - C-Ball Valve	37
12.7. HPM-M15 & HPM-S15 - Injector	39
12.8. HPM-M15 & HPM-S15 - High Shear and Pump Unit	41
13. HPM M15 & HPM S15 (US version), spare parts and drawings	43
13.1. HPM-M15 - Hybrid Powder Mixer, complete (US version)	43
13.2. HPM-M15 - Butterfly Valve (US version)	45
13.3. HPM-M15 - In-line Sight Glass (US version)	47
13.4. HPM-S15 - Hybrid Powder Mixer, complete (US version)	49
13.5. HPM-M15 & HPM-S15 - Flush Tank (US version)	51
13.6. HPM-M15 & HPM-S15 - C-Ball Valve (US version)	53
13.7. HPM-M15 & HPM-S15 - Injector (US version)	55
13.8. HPM-M15 & HPM-S15 - High Shear and Pump Unit (US version)	57
14. Additional documents	59
15. General information	60
15.1. Service and repair	60
15.2. Warranty	60
15.3. How to contact Alfa Laval Kolding A/S	60

1 Declarations of Conformity

EU Declaration of Conformity

The Designated Company

Alfa Laval Kolding A/S, Albuen 31, DK-6000 Kolding, Denmark, +45 79 32 22 00

Company name, address and phone number

Hereby declare that

Hybrid Powder Mixer

Designation

Alfa Laval HPM M15 & HPM S15

Type

Serial number from 50001-50499
Serial number from HP50500-HP60000

is in conformity with the following directives with amendments:

- Machinery Directive 2006/42/EC
- RoHS Directive 2011/65/EU and amendments

The person authorised to compile the technical file is the signer of this document.

Global Product Quality Manager

Title

Lars Kruse Andersen

Name

Kolding, Denmark

Place

2023-06-02

Date (YYYY-MM-DD)



Signature

This Declaration of Conformity replaces Declaration of Conformity dated 2022-11-07



1 Declarations of Conformity

UK Declaration of Conformity

The Designated Company

Alfa Laval Kolding A/S, Albuen 31, DK-6000 Kolding, Denmark, +45 79 32 22 00

Company name, address and phone number

Hereby declare that

Hybrid Powder Mixer

Designation

Alfa Laval HPM M15 & HPM S15

Type

Serial number from 50001-50499

Serial number from HP50500-HP60000

is in conformity with the following directives with amendments:

- The Supply of Machinery (Safety) Regulations 2008
- The Restriction of the Use of Certain Hazardous Substances in Electrical and Electronic Equipment Regulations 2012

Signed on behalf of: Alfa Laval Kolding A/S

Global Product Quality Manager

Title

Lars Kruse Andersen

Name

Kolding, Denmark

Place

2023-06-02

Date (YYYY-MM-DD)

Signature

DoC Revison_02_062023



2 Product programme

This manual covers the product program for Alfa Laval Hybrid Powder Mixer HPM M15 and HPM S15.

2.1 Standard

HPM S15					
Version	Item No	Motor	Funnel	Inlet & Outlet	Motor Voltage
HPM	8010014180	IEC IP55 + Shroud	40 L	DIN	3 Phase 230D/400-415 Y @50Hz
HPM (US version)	8010014182	NEMA TEFC Wash Down (IP66)	40 L	TriClamp	3 Phase 230/460 Vac ($\pm 10\%$) 60Hz

HPM M15					
Version	Item No	Motor	Funnel	Inlet & Outlet	Frequency converter Voltage
HPM	8010014181	IEC IP55 + Shroud	40 L	DIN	3 Phase 380-480 Vac ($\pm 10\%$) 50-60Hz
HPM (US version)	8010014183	NEMA TEFC Wash Down (IP66)	40 L	TriClamp	3 Phase 380-480 Vac ($\pm 10\%$) 50-60Hz

3 Safety

This manual covers the product program for Alfa Laval Hybrid Powder Mixer HPM M15 and HPM S15.

3.1 General hazards

The machine is not dangerous in itself, provided that it is used as intended. To prevent injury to people and damage to the machine, it must only be operated as intended. However, the manufacturer is unable to foresee dangers that may result from installing or combining the machine with other machines. The machine operator must observe the safety instructions when operating the machine. The machine may only be operated by authorised, trained operators. The machine may only be commissioned when fully installed.

3.2 Intended use of the machine

The machine is used for wetting and dispersing powder in fluids and also for blending fluids in fluids. The machine is suitable for producing products with viscosities up to 500 mPas, based on the viscosity at the powder mixer impeller in the case of Newtonian products.

To protect the mixing tools against damage by foreign objects, e.g. screws, stones, pieces of wood, etc., we recommend the use of suitable measures to prevent such objects from entering the machine. The safety mesh provided is one such measure and should be used at all times. Place the safety mesh in the funnel before introducing the powder.

3.3 Protective measures

Operator's duty of care

The machine (including the sub-assemblies) has been designed and built taking into account a risk analysis and after careful selection of harmonised standards and other technical specifications to be observed. It therefore conforms to the state of the art and provides maximum safety in operation.

However, the safety of the machine in practice can only be achieved if all the necessary measures are adopted for this purpose. It is part of the machine operator's duty of care to plan these measures and monitor their implementation.

In particular, the operator must make sure that:

- the machine is only used as intended
 - the machine is only operated if it is in perfect working order and, in particular, the functioning of the safety devices is checked regularly
 - the necessary personal protection for operating, maintenance and repair personnel is both available and worn
 - the operating instructions are always legible and complete versions are available at the place where the machine is installed
 - only duly qualified and authorised personnel operates, maintains and repairs and the machine
 - this personnel is instructed regularly in all relevant issues relating to health and safety in the workplace and protection of the environment and is also familiar with the operating instructions and the safety information contained in those instructions
 - safety and warning information on the machine is not removed and it is legible
-

3.4 Transportation

Goods must be stored and transported in the original packing. Avoid any loading or mechanical stress, in particular of housings, shafts, bearing points, through foreign objects or inadmissible vibration. Goods may only be transported on the load handling equipment provided for this purpose.

4 Specific safety instructions and the symbols used

Unsafe practices and other important information are emphasised in this manual.

Warnings are emphasised by means of special signs.

Always read the manual before using the Mixer!

4.1 Important information

The following operating instructions include specific safety information that refers to unavoidable residual risks when operating and maintaining the machine. The residual risks include risks for:

- people
- product and machine
- the environment

The symbols used in the operating instructions must draw attention to the safety instructions in particular.



WARNING

Indicates that personal danger in particular is to be expected. (danger to life, risk of injury).



CAUTION

This symbol means that danger is to be expected in particular for machine, material and the environment.

NOTE

This symbol is not a safety instruction, but provides information to allow a better understanding of the machine operations.

The English version of the instruction manual is the original manual. We make reservations in regard to possible mistranslations in language versions of the instruction manual. In case of doubt, the English version of the instruction manual applies.

4.2 General safety instructions



Changes may only be made to the installation or parts of it subject to the written consent of ALFA LAVAL, otherwise, the warranty and declaration of conformity will lapse.



The machine is live when the power supply is connected. This voltage can have life-endangering effects on contact. We reserve the right to make technical changes.

4 Specific safety instructions and the symbols used

Unsafe practices and other important information are emphasised in this manual.

Warnings are emphasised by means of special signs.

Always read the manual before using the Mixer!

4.3 Basic safety measures during normal operation



Before switching on the machine, make sure you know what to do in the event of an incident.



The machine may only be operated by qualified, authorised personnel, who are familiar with the operating instructions (including those for the sub-assemblies) and are able to work accordingly!



Replace all hoses regularly as a preventive maintenance measure, even if not obviously damaged). (Observe the manufacturers' information)



If components of the installation are temperature-controlled, there is a risk that parts not insulated and supply lines may catch fire above a temperature of 65°C. In this case, the operator must protect the hot parts against contact.



If water is used as a barrier medium, it must be cooled at temperatures above 85°C, otherwise, the seal may be damaged.

NOTE!

Check the level (sight glass) of the flush tank every day. If the axial face seal is flushed with fresh water, make sure the flow volume is sufficient (0.25-0.5 l/min.).

NOTE!

The machine may not be commissioned (even briefly) if the barrier medium circuit is not intact, otherwise the axial face seal may be destroyed.

NOTE!

The machine is not suitable for processing pure dry substances without the use of fluids. This can cause serious damage to the machine.

NOTE!

When changing the dry substance, check whether the materials of the axial face seal and of the O-rings are still compatible. In some cases, it is necessary to change the parts for different materials. If there is any doubt, consult the supplier.

NOTE!

After all the installation work has been completed, the movement of the drive shaft must be checked on the machine by rotating it manually before the drive is switched on. Make sure the drive cannot be switched on accidentally.

4 Specific safety instructions and the symbols used

Unsafe practices and other important information are emphasised in this manual.

Warnings are emphasised by means of special signs.

Always read the manual before using the Mixer!

4.4 Basic safety measures during maintenance, repair and cleaning



The machine may only be maintained according to the safety instructions by qualified, authorised persons, who are familiar with the operating instructions (and those for the sub-assemblies) and can work accordingly.



Before maintenance and repair work, switch off the main power supply switch and secure with a padlock. The person carrying out the maintenance or repair work must keep the key to this lock.



When changing heavy machine parts, only use suitable and safe load handling devices and sling gear.



Before any maintenance and repair work, make sure that any parts of the machine which may be touched have cooled down to room temperature.

Before any maintenance or repair work, make sure that unauthorised persons cannot access the work area. Attach or set up a sign drawing attention to the maintenance or repair work in progress.



Observe the inspection and maintenance intervals specified in the operating instructions.

Observe the maintenance and repair instructions for sub-assemblies included in these operating instructions.



Dispose of environmentally hazardous lubricants, coolants or cleansing agents in a responsible manner.

NOTE!

After all the installation work has been completed, the movement of the drive shaft must be checked on the machine by rotating it manually before the drive is switched on. Make sure the drive cannot be switched on accidentally.

NOTE!

The rotor shaft nut must be tightened by hand and then with a torque wrench (tightening torque approximately 30 Nm). It is also advisable to lock the thread with a liquid thread lock, such as Loctite, for example.

NOTE!

Any work on the axial face seal must be done very carefully. The seals consist of a brittle material and are therefore sensitive to shocks. Avoid impact.



The cleaning (CIP) of the powder mixer is carried out in combination with the cleaning of the tank or when cleaning the pipe system of the entire installation. The funnel and the ball valve must be removed and replaced by the blind flange supplied. This guarantees that no CIP fluid, such as soda lye or acid, for example, will leak out if the ball valve is opened accidentally.

4 Specific safety instructions and the symbols used

Unsafe practices and other important information are emphasised in this manual.

Warnings are emphasised by means of special signs.

Always read the manual before using the Mixer!

4.5 Working on the electrical equipment

NOTE!

Switch on briefly to check whether the motor is rotating in the direction indicated (arrow on the pump housing).

NOTE!

The machine connection must comply with VDE standards.

When the motor is connected to the power supply, check that the motor voltage, frequency converter and mains voltage correspond.

The voltages are indicated on the motor rating plate or the frequency converter data sheet.



Only qualified electricians may repair the machine's electrical equipment.

Check the electrical equipment regularly.

Re-tighten any loose connections.

Replace damaged lines/cables immediately.

Keep the frequency converter locked and clean at all times!

Only authorised persons with key/tool are allowed access.

Never hose down a frequency converter to clean it.

4.6 Working on the flush tank



The machine must not be commissioned (even briefly) if the barrier medium circuit is not intact, otherwise the axial face seal may be destroyed.

Check that screw connections are firmly tightened after any maintenance or repair work.

After completion of the maintenance or repair work, and before resuming production, make sure that all the materials, tools and other equipment required for carrying out the maintenance or repair work are removed from the work area of the installation and that all the installation's safety devices are functioning properly.

4.7 Observe the environmental protection instructions



The legal obligations relating to the prevention of waste and recycling/disposal must be observed whenever work is done on and with the machine. Particularly when installation, repair and maintenance work is performed, water-hazardous substances, such as:

- Lubricating grease and oil
- Hydraulic fluids
- coolants
- solvent-containing cleaning fluids

do not contaminate the soil or enter the drains.

These substances must be stored, transported, collected and disposed of in suitable tanks.

4 Specific safety instructions and the symbols used

Unsafe practices and other important information are emphasised in this manual.

Warnings are emphasised by means of special signs.

Always read the manual before using the Mixer!

4.8 Residual risks

The machine has been designed so that the machine itself and its accessories cannot cause any risks for people, products and the environment. The operating instructions have been written so that no risks arise when observing warning signs and maintenance specifications.

However, it cannot be ruled out that risks may occur as the result of human error.

No further risks are to be expected if the equipment is used correctly and the recommendations and instructions according to the accident prevention regulations (UVV) and the occupational insurance associations are observed.

5 Functioning

AL HPM

5.1 Function description

The Alfa Laval Hybrid Powder Mixer (AL HPM) is a combination of two technologies (powder mixer and pump) and is mainly used to disperse solids (power or crystals) in fluids. Because of the high pressure that the HPM can generate, even during powder intake (up to 4 bar), it can also be used as a mobile feed or discharge pump or as a CIP pump.

The powder to be mixed is delivered to the HPM via the funnel (item 1 in Figure 1) and homogenised or dispersed in the fluid flow with the aid of a rotor-stator system in the first stage (item 2 in Figure 1). In the second stage, the mixture is then discharged from the equipment with the aid of the impeller (item 3 in Figure 1). During this process, a product sub-flow is recirculated via a second (smaller) connection (item 4 in Figure 1). This sub-flow is introduced into the injector (item 5 in Figure 1). This generates a negative pressure at the funnel outlet, which in turn allows the powder to be drawn in. NOTE: The function is the same on the stationary HPM S15 version shown on figure 2.

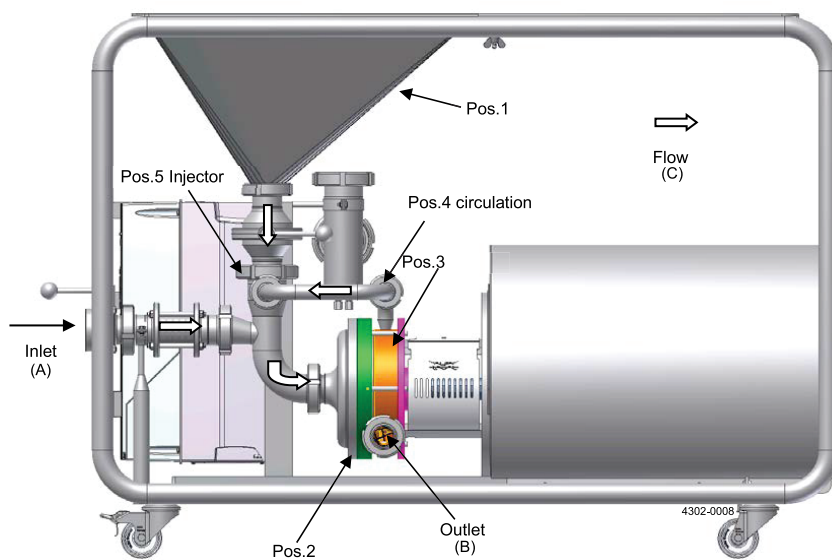

Figure 1

- Pos. 1: Funnel
- Pos. 2: Rotator/stator system
- 1st stage
- Pos. 3: Impeller
- Pos. 4: Circulation
- Pos. 5: Injector
- A: Inlet
- B: Outlet
- C: Flow

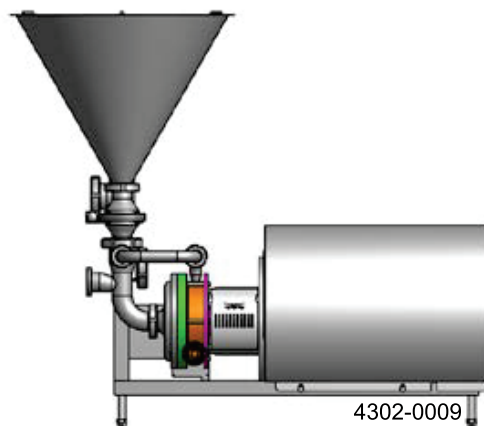

Figure 2

5.2 Construction of the AL HPM

The equipment consists of the following units:

- frequency converter (Only HPM M15)
- drive
- axial face seal
- injector
- rotor/stator, stage 1
- pump impeller, stage 2
- sight glass (Only HPM M15)
- funnel and top plate (Top plate only HPM M15)
- frame with wheels (Only HPM M15)



Figure 3, HPM M15



Figure 4, HPM S15

5 Functioning

AL HPM

Frequency converter (Only on HPM M15)

The frequency converter used is the Danfoss FC 300. Details of the frequency converter are given in the separate operating instructions from Danfoss.

Drive

The power is transmitted from the electric motor to the drive shaft via a three-phase motor. Details of the drive are included in the separate operating instructions for the multi-stage centrifugal pump LKH-112.

Axial face seal

Details of the axial face seal are included in the separate operating instructions for the multi-stage centrifugal pump LKH-112.

Injector

The injector allows the powder to be drawn into the fluid and generates the preliminary mixing of the two components. It consists of a removable housing with a central suction pipe through which the component from the funnel is blended. The sub-flow from the second stage of the pump serves as the propellant medium for the injector, which is made possible via the small recirculation pipe (see Figure 5).

NOTE: HPM S15 is supplied WITHOUT inlet valve.

A: Powder

B: Injector

C: Liquid

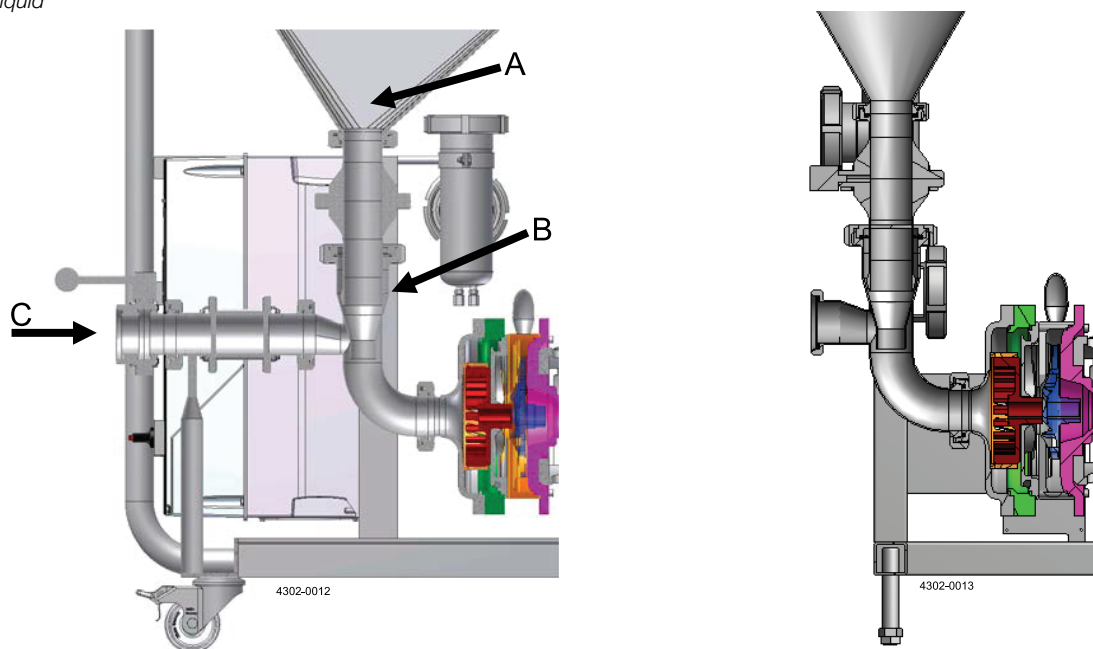
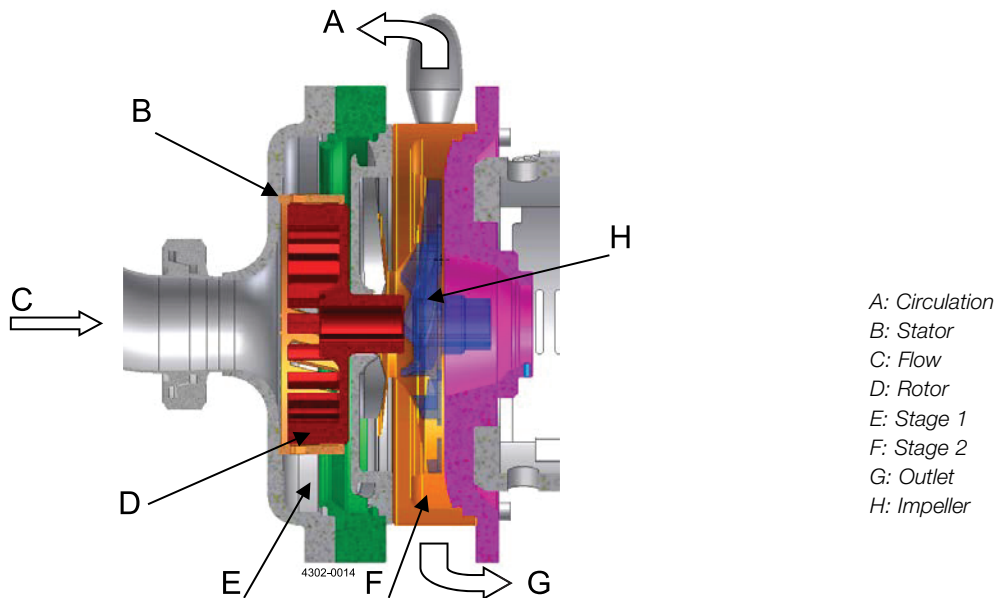

Figure 5

Rotor/stator , stage 1

The rotor/stator system is located on the drive shaft, upline of the pump impeller and downline of the injector. The main job of the rotor/stator is to disperse the powder in the fluid.

**Pump impeller, stage 2**

The impeller is located on the drive shaft downline of the rotor/stator. The main job of the impeller is to deliver the powder/fluid mixture back to the tank at high pressure and deliver a sub-flow back to the injector via the circulation pipe (see Figure 6).

Sight glass (Only HPM M15)

The sight glass is located in the HPM supply and is used to observe the fluid flow visually.

Funnel and cover plate (Cover plate only HPM M15)

The funnel consists of two parts: the funnel itself, into which the powder is delivered, and the funnel cover plate, which is mainly used as a support surface for the product. After cleaning, the cover plate is placed on the funnel and therefore protects it from pollution in the funnel room outside operating hours.

Frame (Only HPM M15)

The modular frame is made from easy to clean tubing and allows safe and easy handling of the HPM. The frame stands on rollers, the complete system is mobile.

6 Setting up and installation

AL HPM

6.1 Unpacking and setting up

When unpacking, check all parts for damage in transit. Damaged parts must not be used. In the event of any damage, notify the transport company and relevant transport insurance company immediately.

A suitably qualified member of staff must unpack, clean and assemble the machine in accordance with the installation instructions.

Goods must be stored and transported in the original packing. Avoid any loading or mechanical stress, in particular of housings, shafts, bearing points, through foreign objects or inadmissible vibration. Goods may only be transported on the load handling equipment provided for this purpose.

The machine must be set up safely on the floor so that it is easily accessible.

The machine must not be exposed to any heat radiation or technical magnetic fields. No stands for people or other heavy objects may be attached to the machine. The machine must not be set up in traffic areas. It must be accessible for maintenance and operation at all times.

Install the machine as near to the production tank as possible.

Lock the rollers to prevent uncontrolled movement of the machine.

6.2 Connecting the product pipes

The product inlet and outlet must be firmly and tightly connected to the tank's circulation pipe (see Figure 7). Keep the product inlet pipe (intake pipe) as short as possible and do not use a diameter smaller than the connection of the unit. Use bigger diameters for increased viscosity in order to reduce the pressure drop on the suction side.

6.3 Flush tank and axial face seal

The flush tank and axial face seal can be operated in two ways:

1. Closed-circuit type with a defined volume of barrier fluid
2. Flushed type, where fresh water flows through the axial face seal and then into the gully (0.25-0.5 L/minute).

In order to guarantee the necessary circulation of the barrier medium through the axial face seal, the hoses have to be correctly connected to the barrier medium tank.

The barrier medium used should have the following characteristics:

- low viscosity (similar to water, approximately 1 mPas)
- good lubrication capability
- good thermal conductivity
- product neutrality

Water with a 25% addition of glycerine or glycol is used as the barrier medium as standard.

The barrier fluid should reach the middle of the sight glass. At this level, the fill corresponds to approximately 0.7 litres. It only usually has to be replaced if it becomes polluted.

After filling, the circuit and the axial face seal in particular should be vented. To do this, undo the return hose on the flush tank and wait until fluid emerges. Then tighten again.

6.4 Power supply

Since no dangerous movements are accessible on the machine, no emergency stop has been provided.

The machine connection must comply with VDE standards. When the motor is connected to the power supply, check that the motor voltage, frequency converter and mains voltage correspond.

The motor voltage is indicated on the motor rating plate or the frequency converter data sheet. Details of the frequency converter are given in the attached operating instructions for the frequency converter.

7 Commissioning

AL HPM

The operator must observe VDE standard 0530 when commissioning the machine.

The machine may only be operated by trained, authorised operating personnel. Never commission the machine if it is not fully installed.

Before commissioning, remove all dirt and foreign objects from the machine and the connected pipes and tanks. Check that machine rotor and stator are running freely and free from contact.

7.1 Connecting the AL HPM to a mixing tank

Before commissioning, the AL HPM must be permanently piped to a tank in which the powder solution is produced (see Figure 7, circulation pipe). Hoses approved for the operation may also be used.

Make sure that during operation, ideally, a back-pressure of approximately 2 bar is generated after the outlet of the HPM to allow optimum powder intake (1 bar would also be possible). This can be achieved with the aid of an Isomix jet mixer (see Figure 7) installed in the tank at the end of the circulation pipe. This has the advantage that optimum intermixing is achieved inside the tank.

After mixing, the Isomix rotating jet mixer can also be used to clean the tank (CIP).

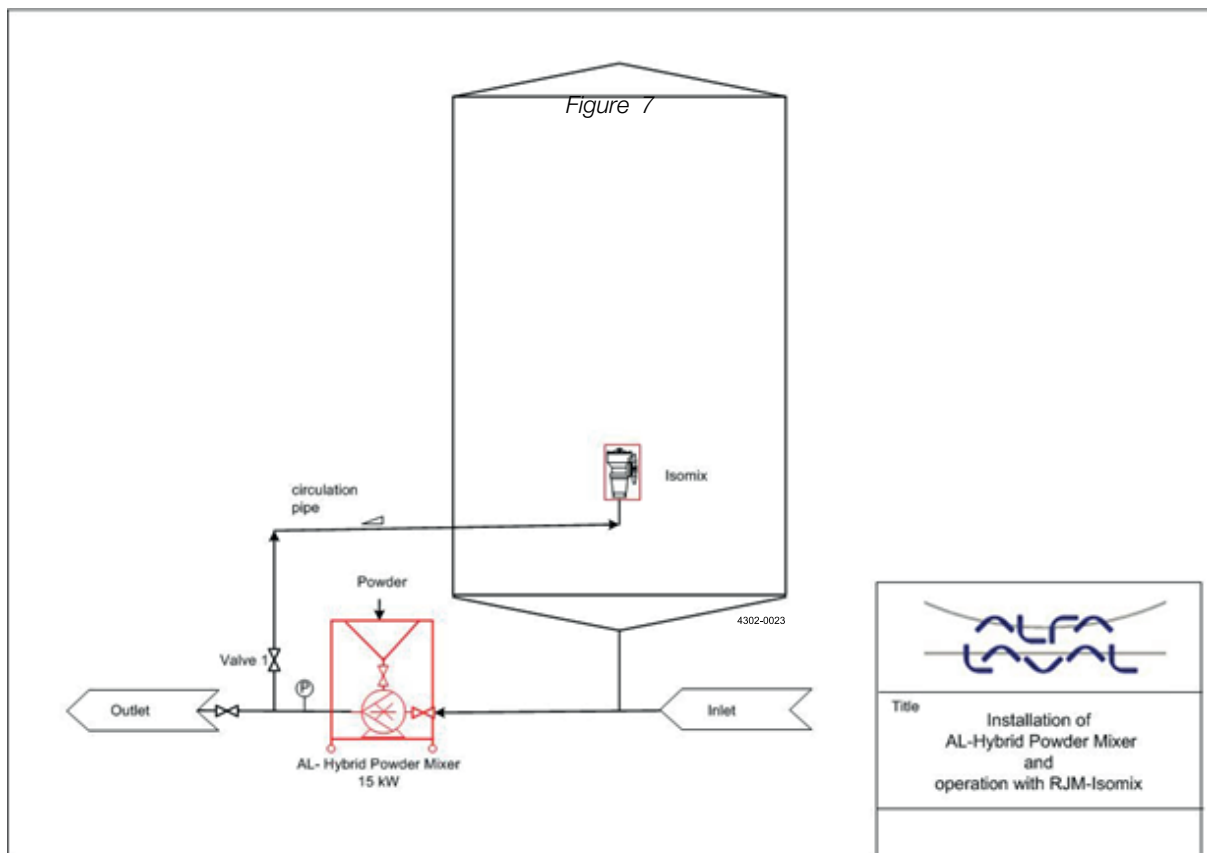

AL HPM

If there is no Isomix to generate the back-pressure, a simple manual valve (see Figure 7, valve 1), which is connected after the HPM and serves as a throttle, can be used. We recommend that a pressure gauge is always provided after the HPM in order to check the back-pressure generated.

We also recommend positioning the HPM inlet at least 200 mm lower than the tank outlet so that the fluid can flow freely into the mixer. The circulation pipe return should be piped so that no air pockets can form in the pipes. The highest point should be the Isomix or the product inlet in the tank (see Figure 7).

When connecting permanent pipes, it is also advisable to include a compensator in the pipe in some circumstances.

The barrier medium circuit must be filled with a suitable medium before commissioning the machine for the first time (see page 1917, Flush tank and axial face seal).

The machine may not be commissioned (even briefly) if the barrier medium circuit is not intact, otherwise the axial face seal may be destroyed.

7.2 Brief test

Check the following again with a short trial run:

1. contamination in the funnel
 2. set the valve on the funnel outlet to the closed position
 3. the direction of rotation of the motor
 4. the fluid level in the flush tank
 5. check for any unusual mechanical noises
-

7 Commissioning

AL HPM

7.3 Information on working with products

The AL HPM has been designed in particular for mixing solids and fluids. However, the following things also need to be taken into account to work with the machine successfully:



Powders difficult to dissolve or those that swell extensively and have a tendency to stick may only be added in very small quantities, because otherwise the machine may become clogged. Always turn on the ball valve under the funnel slowly and check the intake behaviour at the same time.



Never deposit BIG bags on the modular frame because their weight may damage it.

7.4 Powering up the machine

A minimum fluid volume is required for the machine to function and this has to be introduced into the mixing tank.

Please perform the following operations in the order listed when commissioning the machine:

- close the ball valve underneath the funnel.
 - open all the valves in the circulation pipe.
 - check via the sight glass in the machine inlet whether the fluid is flowing into the machine automatically. If it is, wait until the pipe fills.
 - Switch the machine on via the frequency converter and pump the fluid in the circuit.
 - With the frequency converter, increase the frequency to 60 Hz (see the frequency converter operating instructions).
 - If there is no Isomix mixer in the mixing tank, it must be ensured that a back-pressure of approximately 2 bar is built up by throttling the valve downline of the HPM. Since the valve and the pressure gauge are not part of the supply, the operator has to install these components.
 - Insert the safety mesh in the funnel.
 - Introduce powder into the funnel.
 - Slowly open the ball valve underneath the funnel.
 - With hardly soluble powders, the ball valve should only be opened 10%-15%.
 - With easily soluble powders, the ball valve may be opened 100%.
 - Make sure that during the powder intake, no air pockets form in the powder, as otherwise, air can be entrained into the system. Air pockets should be avoided and any that occur should be dislodged immediately (manually).
 - After the powder has been drawn in, close the ball valve immediately and only open it again when powder is next added. Never aspirate air into the system.
 - Since the suction power is reduced with increasing viscosity, make sure that the maximum viscosity of 500 cP in the mixer is not exceeded. (500 cP in the case of Newtonian products).
-

AL HPM

8.1 Cleaning (CIP)

The unit has to be cleaned regularly, depending on the type of operation. Dirt in the pipes and chambers can lead to contamination and therefore pollution of the product (when next commissioned).

The cleaning (CIP) of the machine is carried out in combination with the cleaning of the tank or when cleaning the pipe system of the entire installation.

The funnel and the ball valve, which should be cleaned manually, have to be removed and replaced by the blind flange supplied. This guarantees that no CIP fluid, such as lye or acid can escape if the ball valve is opened accidentally.

8.2 The axial face seal

Details of the maintenance of the axial face seal are included in the attached operating instructions for the multi-stage centrifugal pump LKH.

8.3 C-Ball Valve

The seal housing of the ball valve should be checked regularly. The operator can decide on the checking intervals himself, because it very much depends on the types of powder used.

8.4 Rotor/Stator

The high-seed rotor, and also the stator, react sensitively to foreign objects. Therefore, objects such as, for example, screws, stones, welding beads, etc. must be prevented from entering the machine.

In the case of highly adhesive and curing media, the machine should also be flushed immediately at the end of the operation. Depending on the abrasiveness of the mixed product, the mixing tools are exposed to a certain amount of wear. Since the size of the shear gap can affect the mixing quality, the tools need to be checked for wear from time to time. The operator can decide on the checking intervals himself, because it very much depends on the types of powder used.

8.5 Barrier fluid installation

Daily fluid level check.

Occasional check of the leak-tightness of the hoses, particularly in the area of screw connections.

8.6 Drive

Details of the drive are included in the separate operating instructions for the multi-stage centrifugal pump LKH.

NOTE!

Please note that the first step of the pump is modified compared to the standard LKH.

9 Installation and removal

AL HPM

After all the installation work has been completed, the movement of the drive shaft must be checked on the machine by rotating it manually before the drive is switched on. Make sure the drive cannot be switched on accidentally.

Before any maintenance and repair work, switch off the main power supply switch and lock with a padlock. The person carrying out the maintenance or repair work must hold the key to this lock.

9.1 Rotor/Stator

Removal of the Rotor/Stator

1. Isolate the AL HPM from the mains
2. Remove the funnel and cover plate
3. Disconnect supply pipes from solid and fluid pipes.
4. Undo and remove 6 cap nuts from the pump housing
5. Remove the complete pump housing with stator from the machine

Fitting the Rotor/Stator

Fit the tools in the reverse order to their removal:

To make removal easier, first lightly grease the hubs of the tools with a suitable grease.

When fitting, make sure that the O-rings of the individual tools lie correctly in the groove when they are stacked.

Firmly tighten the shaft cap nuts with a torque wrench (tightening torque approximately 30 Nm). We also recommend locking the thread with a liquid thread lock, such as Loctite, for example.

9.2 Installing the drive

Details for installing the drive are included in the separate operating instructions for the multi-stage centrifugal pump LKH.

AL HPM

10.1 Hybrid Powder Mixer HPM S15 and M15

Hybrid Powder Mixer	HMP	HPM (US version)
Motor		
Mounting:	Std. foot-flanged	Std. C-Face footed
Power:	15 kW	20 Hp
Frequency	50 Hz	60 Hz
RPMs (2-poles):	3000/3600 RPM	3600 RPM
Voltage:	230D/400-415 Y	230/460 VAC
Efficiency:	IE3	Premium
Enclosure:	IEC - IP55 incl. SS motor shroud	NEMA - TEFC Wash down
Connections		
Liquid inlet:	DN 50 male union	TriClamp 2"
Liquid outlet:	DN 40 male union	TriClamp 1½"
Materials		
Product wetted steel parts:	1.4404 (316L) and 1.4462 (2205)	
Other steel parts:	1.4301 (304)	
Product wetted seals:	EPDM	
C-Ball Valve:	FPM	
Finish:	Semi-Bright	
Internal surface roughness:	Pipework acc. to DIN11850, all pickled and passivated (Internal surface Ra<0.8 µm, Internal welded area Ra<1,6 µm)	
Pump impellers:	Blasted	Polished
Shaft seal, pump unit:	Single mechanical SiC/SiC, flushed version	
Other		
Control of powder addition:	Manually actuated special C-Ball Valve for dry ingredient adding	
Flush tank:	Approx. 1 ltr. incl. sight glass. Note: Flush through possible via easy connection	
CIP:	Blind cover at powder inlet for use during CIP	
Frequency Converter (only M15)		
Type:	Danfoss VLT® AutomationDrive FC 300 series	
Power rating:	18.5 kW / 25 hp (Normal overload 110 %/60 s)	
Input voltage	380-480 VAC	
RFI class:	Class A1/B	

11 Operational data

AL HPM

11.1 Technical data

Rotor speed (60 Hz)	3,500 rpm.
Maximum admissible product temperature	70°C (temperature above can cause cavitation in the venturi area)
Maximum admissible operating overpressure	10 bar
Maximum Throughputs	29 m ³ /h

*The values apply to the standard speed of 3,500 rpm., water at 20°C
The throughput drops with increasing viscosity of the mixed product at the same speed.*

Temperature range:	-10°C to +95°C (NOTE: 95°C only during CIP)
Recommended inlet pressure:	0.0 – 0.2 bar
Min. back pressure recommended:	1 bar
Dry ingredient capacity:	Dependent on powder (e.g. 3000 kg/h capacity for skimmed milk powder)
Noise level (at 1 m):	< 90 dB(A)

11.2 Dimensions/weight

	HPM M15	HPM S15
HxWxL [mm]:	1130 x 826 x 1340	1115 x 580 x 1300
Weight:	Approx. 280 kg	Approx. 230 kg
Max. table load:	300 kg	-

12 HPM M15 & HPM S15, spare parts and drawings

HPM-M15 - Hybrid Powder Mixer, complete

12.1 HPM-M15 - Hybrid Powder Mixer, complete

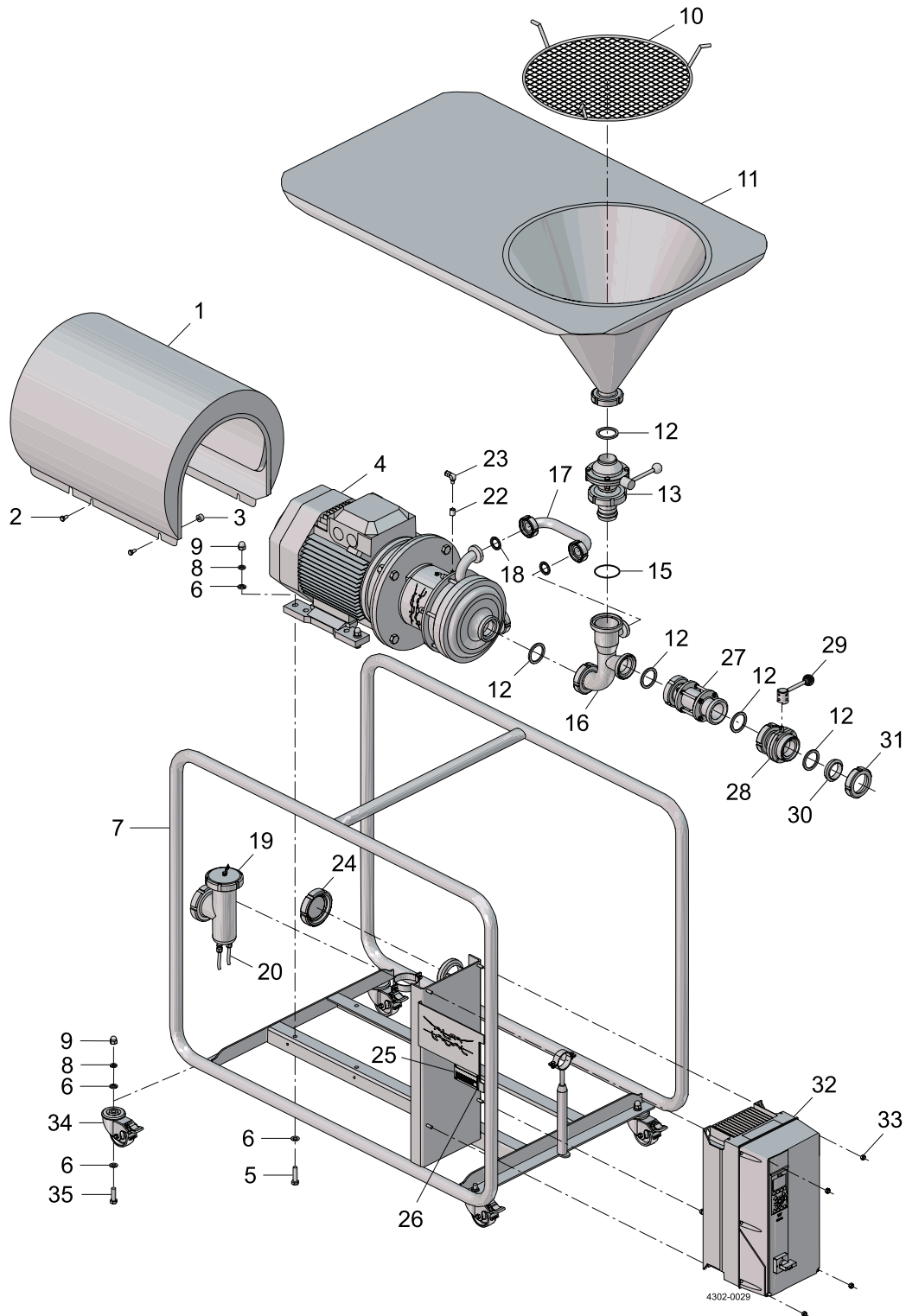

12 HPM M15 & HPM S15, spare parts and drawings

HPM-M15 - Hybrid Powder Mixer, complete

Parts list

Pos.	Qty	Denomination
1	1	Shroud
2	4	Self Locking Screw
3	4	Spacer
4	1	Pump Unit
5	4	Screw
6	16	Washer
7	1	Frame
8	8	Washer
9	8	Nut
10	1	Sieve
11	1	Funnel w. Plate
12	4	Gasket
13	1	C-Ball Valve
15	1	O-ring
16	1	Injector
17	1	Bypass
18	2	Gasket
19	1	Flush Tank
20	1m	Tube
21	4	Insert
22	2	Sleeve
23	2	Stud Elbow
24	1	End Cap
25	1	Name Plate
26	4	Blind Rivet
27	1	Sight Glass
28	1	Butterfly Valve
29	1	Handle
30	1	Liner
31	1	Nut
32	1	Frequency Converter
33	4	Nut
34	4	Swivel Castor
35	4	Screw

12 HPM M15 & HPM S15, spare parts and drawings

HPM-M15 - Butterfly Valve

12.2 HPM-M15 - Butterfly Valve

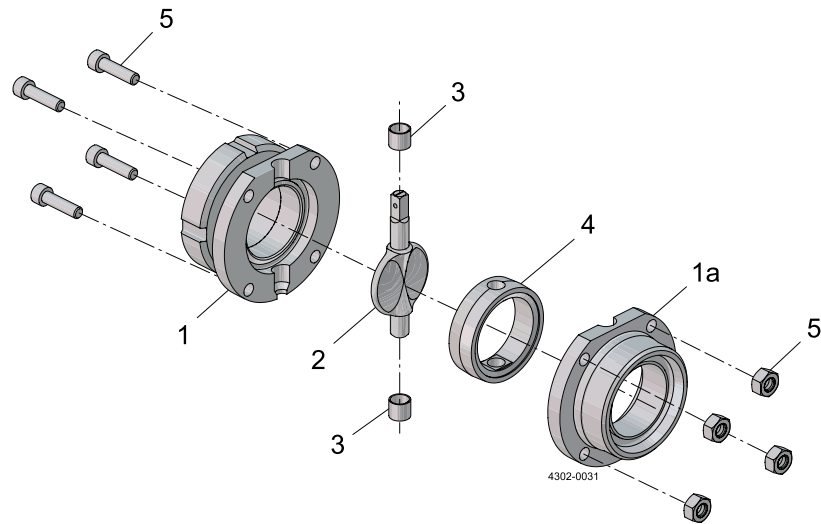

12 HPM M15 & HPM S15, spare parts and drawings

HPM-M15 - Butterfly Valve

Parts list

Pos.	Qty	Denomination
1 <input type="checkbox"/>	1	Valve body half, nut/liner
1a <input type="checkbox"/>	1	Valve body half, male part
2	1	Disc
3 <input checked="" type="checkbox"/>	2	Bush
4 <input checked="" type="checkbox"/>	1	Seal ring
5 <input checked="" type="checkbox"/>	1	Seal ring
5	4	Screw and nut set

Service kits

Denomination

Service Kits for product wetted parts

9611923078¹⁾

9611923094²⁾

¹⁾ Parts marked with are included in the Service Kit, EPDM: 9611923078

²⁾ Parts marked with are included in the Service Kit, FPM: 9611923094

Configuration according to delivery note/order.

12 HPM M15 & HPM S15, spare parts and drawings

HPM-M15 - In-line Sight Glass

12.3 HPM-M15 - In-line Sight Glass

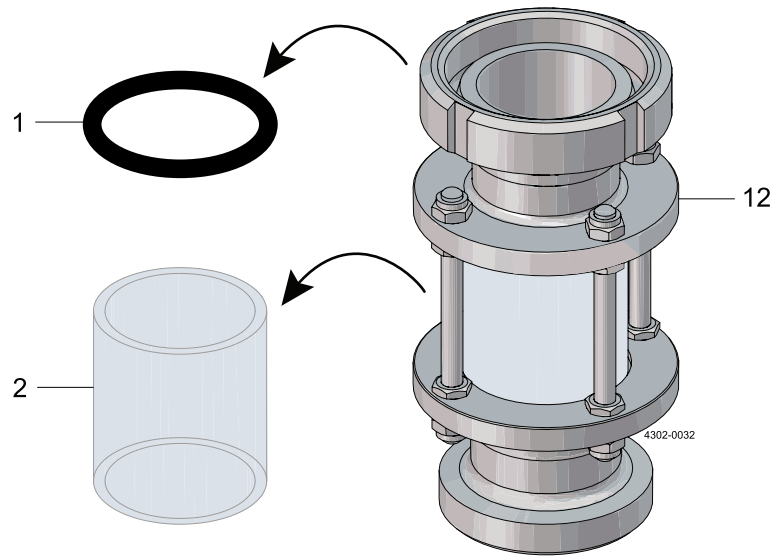

12 HPM M15 & HPM S15, spare parts and drawings

HPM-M15 - In-line Sight Glass

Parts list

Pos.	Qty	Denomination
1	1	Seal ring
2	1	Glas tube
12	1	Sight glass

12 HPM M15 & HPM S15, spare parts and drawings

HPM-S15 - Hybrid Powder Mixer, complete

12.4 HPM-S15 – Hybrid Powder Mixer, complete

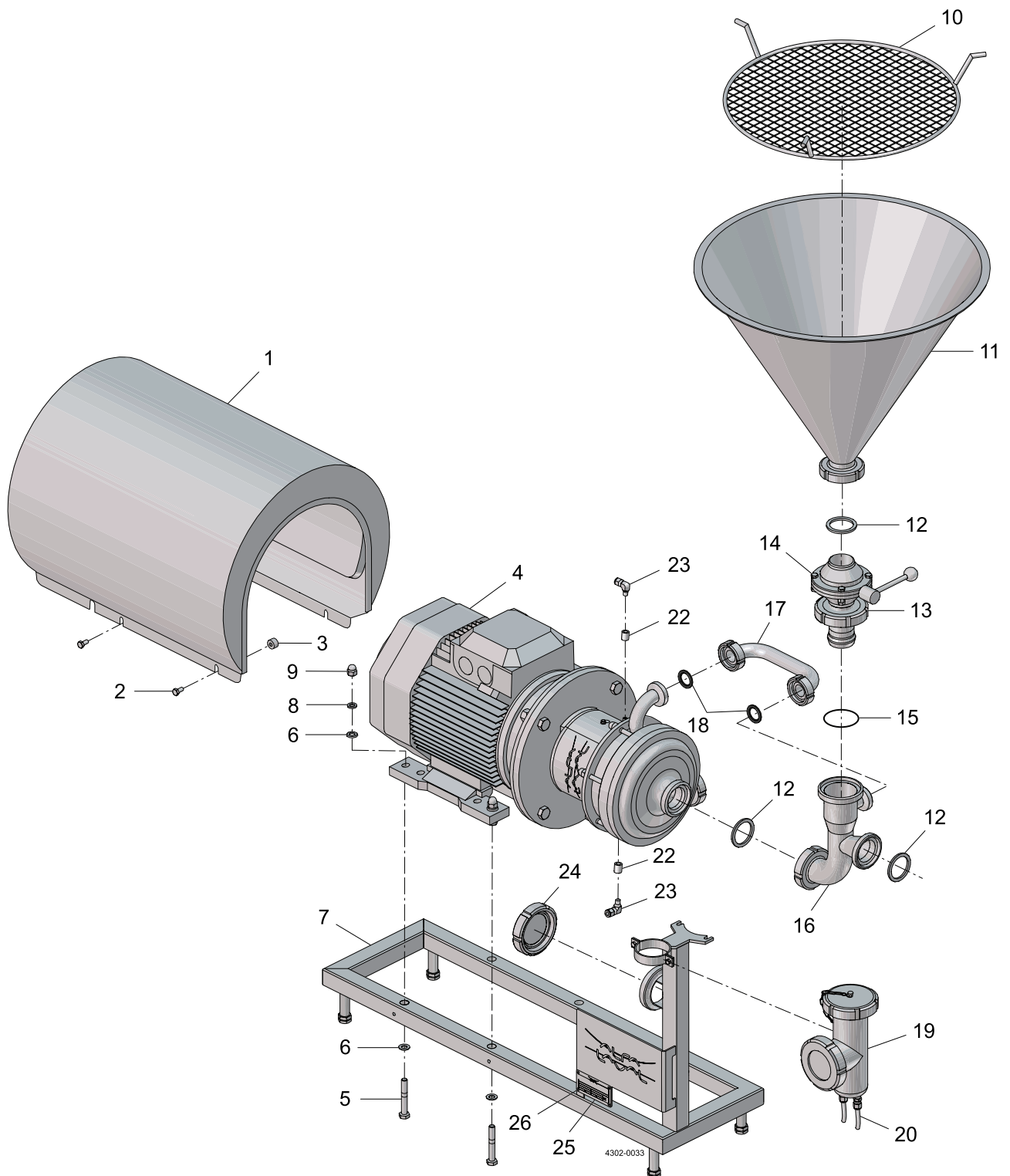

12 HPM M15 & HPM S15, spare parts and drawings

HPM-S15 - Hybrid Powder Mixer, complete

Parts list

Pos.	Qty	Denomination
1	1	Shroud
2	4	Self Locking Screw
3	4	Spacer
4	1	Pump Unit
5	4	Bolt
6	8	Washer
7	1	Frame
8	4	Washer
9	4	Nut
10	1	Sieve
11	1	Funnel
12	3	Gasket
13	1	C-Ball Valve
14	2	Screw
15	1	O-ring
16	1	Injector
17	1	Bypass
18	2	Gasket
19	1	Flush Tank
20	1m	Tube
21	4	Insert
22	2	Sleeve
23	2	Stud Elbow
24	1	End Cap
25	1	Name Plate
26	4	Blind Rivet

12 HPM M15 & HPM S15, spare parts and drawings

HPM-M15 & HPM-S15 - Flush Tank

12.5 HPM-M15 & HPM-S15 - Flush Tank

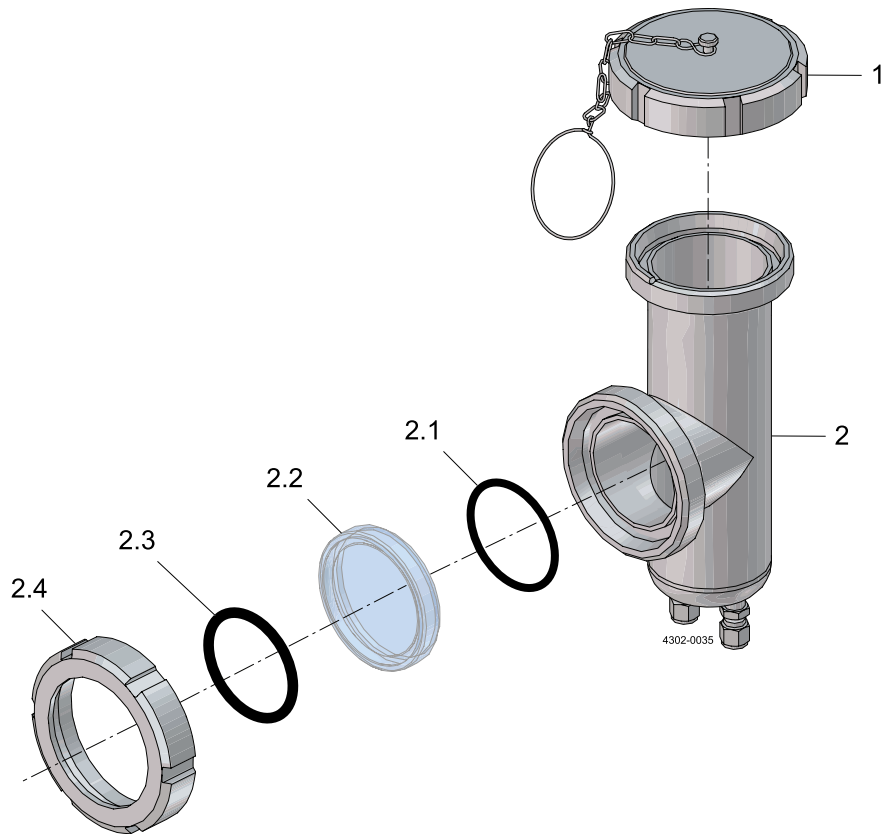

12 HPM M15 & HPM S15, spare parts and drawings

HPM-M15 & HPM-S15 - Flush Tank

Parts list

Pos.	Qty	Denomination
1	1	End Cap
2	1	Flush Tank House
2.1	1	Seal
2.2	1	Sight glass
2.3	1	Seal
2.4	1	Nut, union

12 HPM M15 & HPM S15, spare parts and drawings

HPM-M15 & HPM-S15 - C-Ball Valve

12.6 HPM-M15 & HPM-S15 - C-Ball Valve

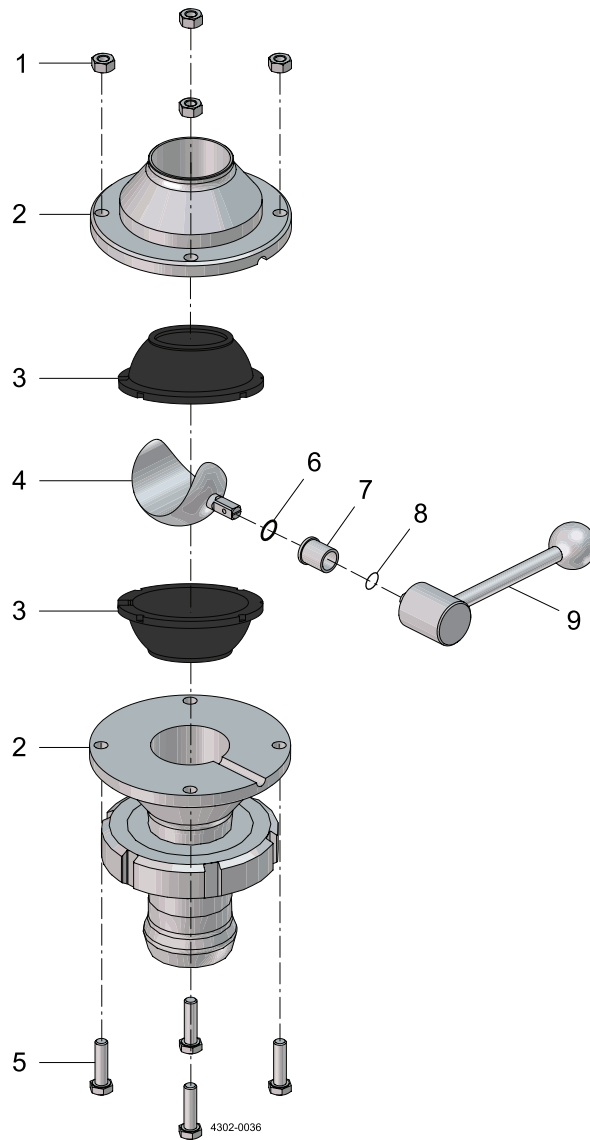

12 HPM M15 & HPM S15, spare parts and drawings

HPM-M15 & HPM-S15 - C-Ball Valve

Parts list

Pos.	Qty	Denomination
1	4	Nut
2	-	Housing complete
3 ♦	2	Seal
4	1	C-Ball w. shaft
5	4	Bolt
6 ♦	1	O-ring
7 ♦	1	Guide sleeve
8 ♦	1	Snap ring
9	1	Handle for C-Ball Valve

Service kits

Denomination

Service Kits & Service Valve

9614451701¹⁾

8010000839²⁾

8010004893³⁾

¹⁾ Parts marked with ♦ are included in the standard Service kit in FPM for C Ball valve: Item no. 9614451701

²⁾ Service Kit PTFE can be used for special applications where the Service Kit FPM does not work properly: Item no. 8010000839

³⁾ Service Valve to replace C-Ball Valve in use while servicing it: Item no. 8010004893

NOTE

From and with serial number 50083 the Hybrid Powder Mixers were born with FPM Sealing. Before that it was PTFE sealing.

12 HPM M15 & HPM S15, spare parts and drawings

HPM-M15 & HPM-S15 - Injector

12.7 HPM-M15 & HPM-S15 - Injector

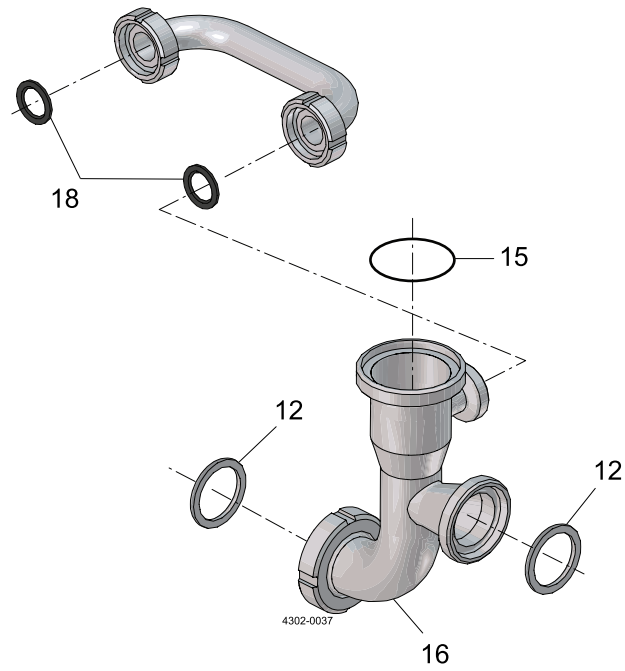

12 HPM M15 & HPM S15, spare parts and drawings

HPM-M15 & HPM-S15 - Injector

Parts list

Pos.	Qty	Denomination
12	2	Gasket
15	1	O-ring
16	1	Injector
18	2	Gasket

12 HPM M15 & HPM S15, spare parts and drawings

HPM-M15 & HPM-S15 - High Shear and Pump Unit

12.8 HPM-M15 & HPM-S15 - High Shear and Pump Unit

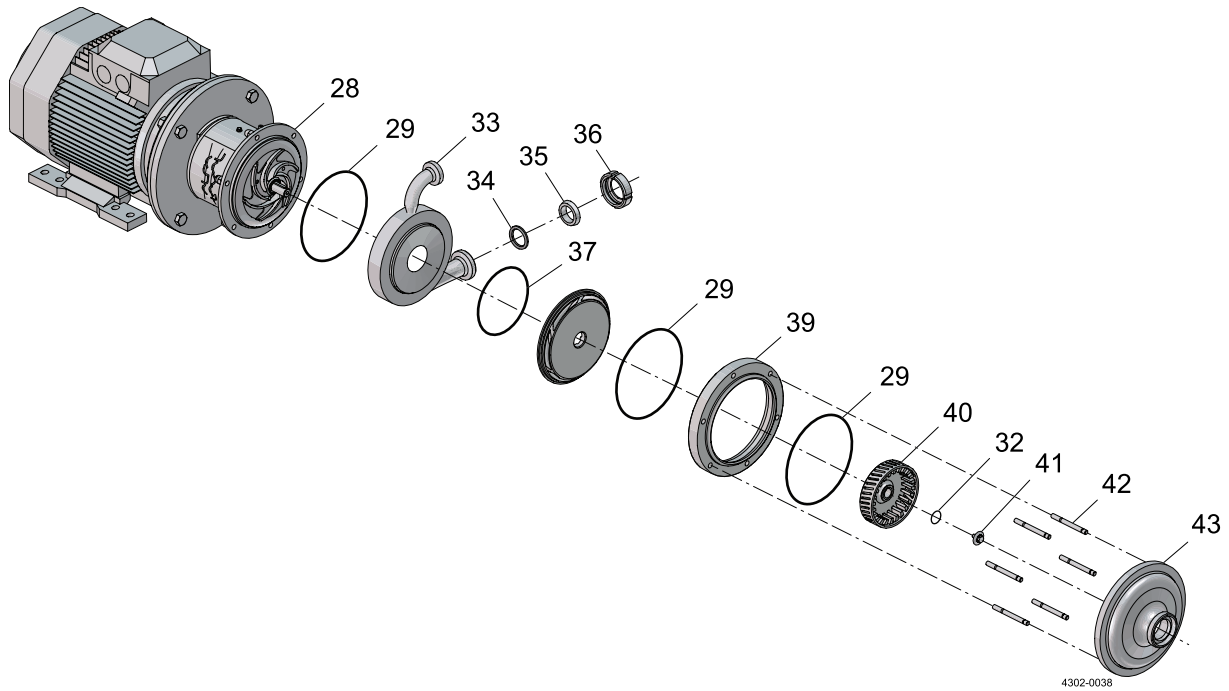

12 HPM M15 & HPM S15, spare parts and drawings

HPM-M15 & HPM-S15 - High Shear and Pump Unit

Parts list

Pos.	Qty	Denomination
28	1	Backplate
29 ✧	3	O-ring
●	3	O-ring
32	2	O-ring
33	1	Pump Housing
34	1	Gasket
35	1	Liner
36	1	Nut
37	1	O-ring
39	1	Flange
40	1	Rotor
41	1	Impeller Screw
42	6	Bolt
43	1	Pump Cover

Service kits

Denomination

Service Kits

9611922660¹⁾

9611922658²⁾

Please see parts list for LKH-112 in separate pump manual.

The parts above are either additional, revised or replaced by components of the LKH-112 pump except for the service kits.

1) Parts marked with ✧ are included in the Service Kit, FPM: 9611922660

2) Parts marked with ● are included in the Service Kit, EPDM: 9611922658

13 HPM M15 & HPM S15 (US version), spare parts and drawings

HPM-M15 - Hybrid Powder Mixer, complete (US version)

13.1 HPM-M15 – Hybrid Powder Mixer, complete (US version)

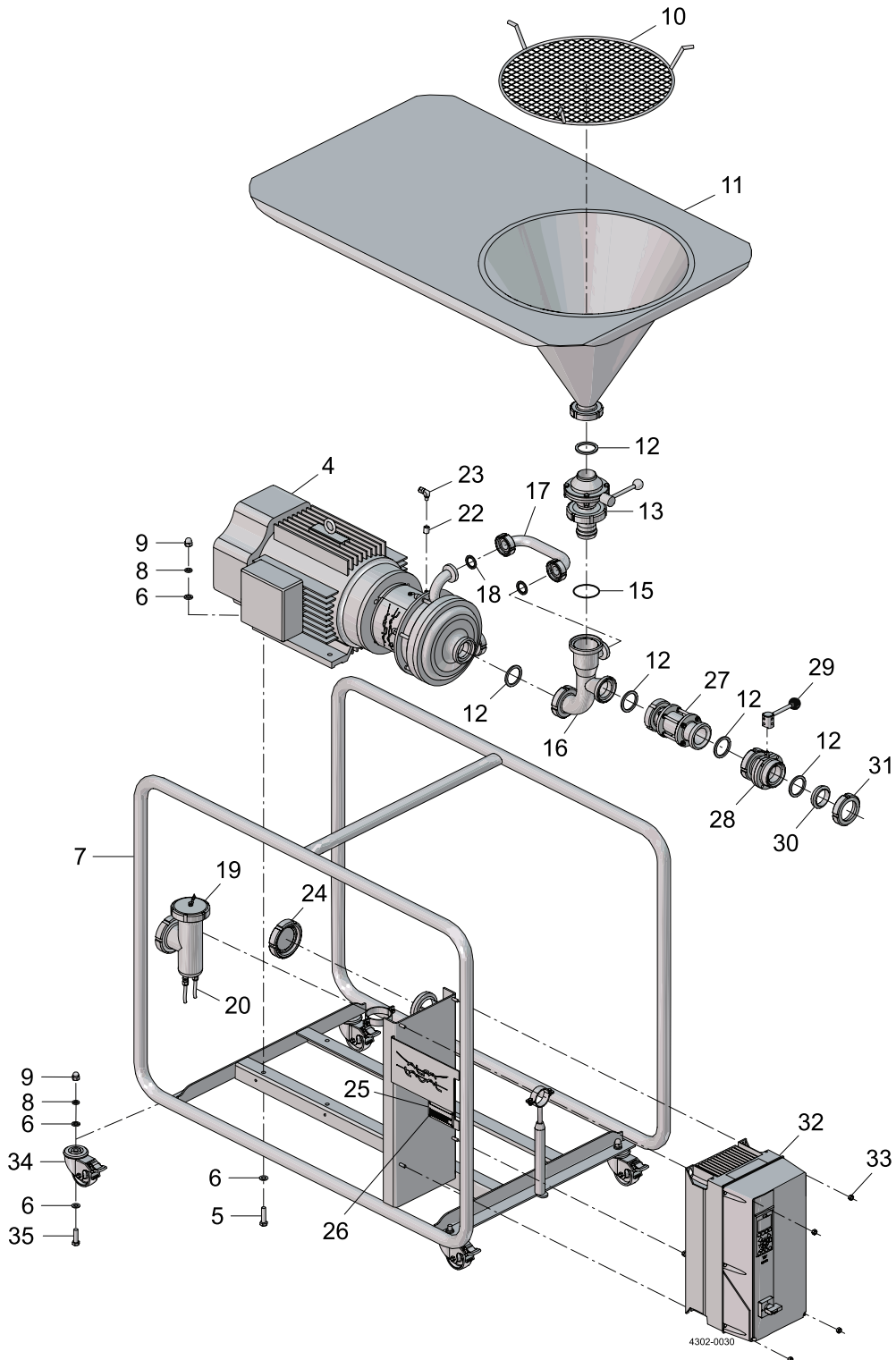

13 HPM M15 & HPM S15 (US version), spare parts and drawings

HPM-M15 - Hybrid Powder Mixer, complete (US version)

Parts list

Pos.	Qty	Denomination
1		
2		
3		
4	1	Pump Unit
5	4	Screw
6	16	Washer
7	1	Frame
8	8	Washer
9	8	Nut
10	1	Sieve
11	1	Funnel w. Plate
12	4	Gasket
13	1	C-Ball Valve
15	1	O-ring
16	1	Injector
17	1	Bypass
18	2	Gasket
19	1	Flush Tank
20	1m	Tube
21	4	Insert
22	2	Sleeve
23	2	Stud Elbow
24	1	End Cap
25	1	Name Plate
26	4	Blind Rivet
27	1	Sight Glass
28	1	Butterfly Valve
29	1	Handle
30	1	Liner
31	1	Nut
32	1	Frequency Converter
33	4	Nut
34	4	Swivel Castor
35	4	Screw

13 HPM M15 & HPM S15 (US version), spare parts and drawings

HPM-M15 - Butterfly Valve (US version)

13.2 HPM-M15 – Butterfly Valve (US version)

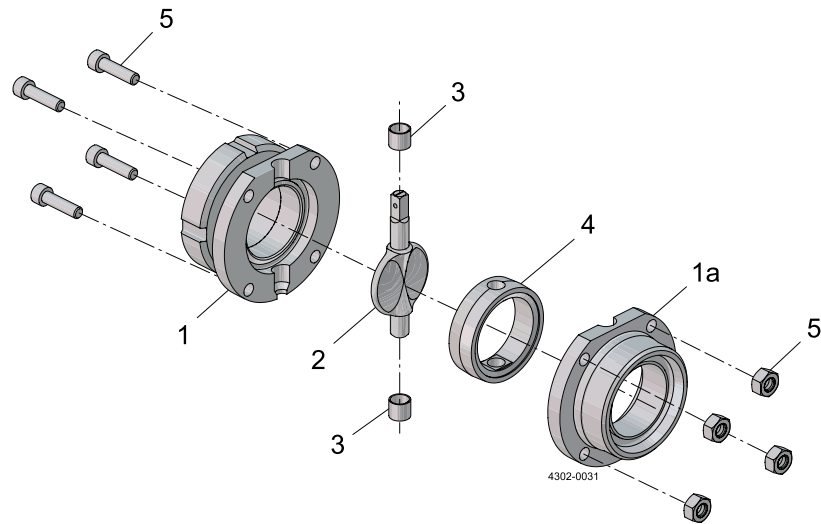

13 HPM M15 & HPM S15 (US version), spare parts and drawings

HPM-M15 - Butterfly Valve (US version)

Parts list

Pos.	Qty	Denomination
1 <input type="checkbox"/>	1	Valve body half, nut/liner
1a <input type="checkbox"/>	1	Valve body half, male part
2	1	Disc
3 <input checked="" type="checkbox"/>	2	Bush
4 <input checked="" type="checkbox"/>	1	Seal ring
	1	Seal ring
5	4	Screw and nut set

Service kits

Denomination

Service Kits for product wetted parts

9611923078¹⁾

9611923094²⁾

¹⁾ Parts marked with are included in the Service Kit, EPDM: 9611923078

²⁾ Parts marked with are included in the Service Kit, FPM: 9611923094

Configuration according to delivery note/order.

13 HPM M15 & HPM S15 (US version), spare parts and drawings

HPM-M15 - In-line Sight Glass (US version)

13.3 HPM-M15 - In-line Sight Glass (US version)

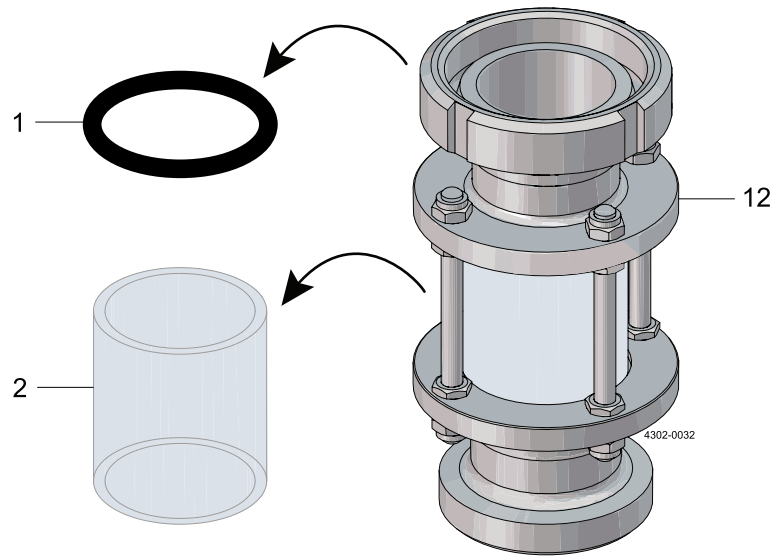

13 HPM M15 & HPM S15 (US version), spare parts and drawings

HPM-M15 - In-line Sight Glass (US version)

Parts list

Pos.	Qty	Denomination
1	1	Seal ring
2	1	Glas tube
12	1	Sight glass

13 HPM M15 & HPM S15 (US version), spare parts and drawings

HPM-S15 - Hybrid Powder Mixer, complete (US version)

13.4 HPM-S15 – Hybrid Powder Mixer, complete (US version)

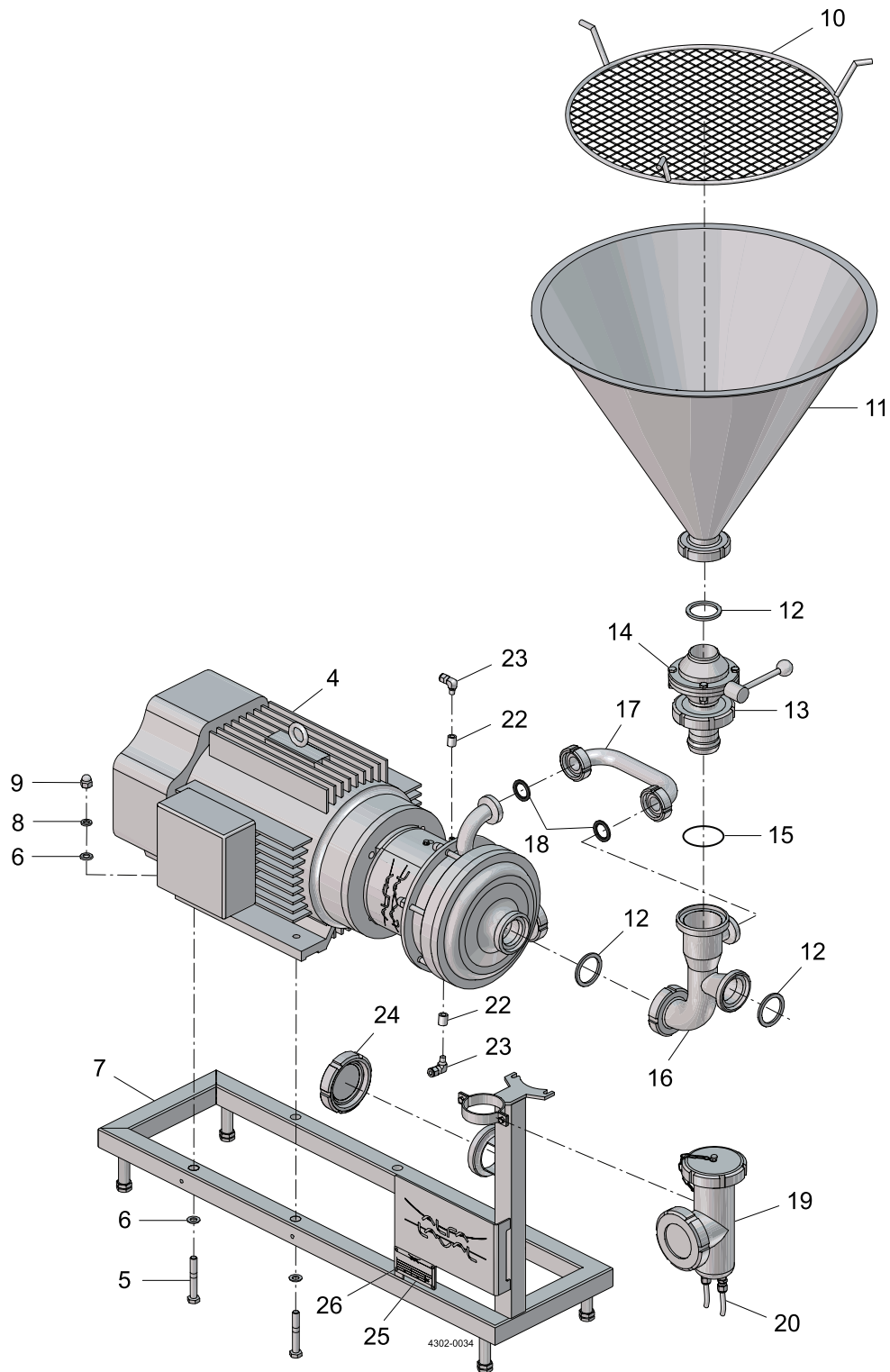

13 HPM M15 & HPM S15 (US version), spare parts and drawings

HPM-S15 - Hybrid Powder Mixer, complete (US version)

Parts list

Pos.	Qty	Denomination
4	1	Pump Unit
5	4	Bolt
6	8	Washer
7	1	Frame
8	4	Washer
9	4	Nut
10	1	Sieve
11	1	Funnel
12	2	Gasket
13	1	C-Ball Valve
14	2	Screw
15	1	O-ring
16	1	Injector
17	1	Bypass
18	2	Gasket
19	1	Flush Tank
20	1m	Tube
21	4	Insert
22	2	Sleeve
23	2	Stud Elbow
24	1	End Cap
25	1	Name Plate
26	4	Blind Rivet

13 HPM M15 & HPM S15 (US version), spare parts and drawings

HPM-S15 - Hybrid Powder Mixer, complete (US version)

13.5 HPM-M15 & HPM-S15 - Flush Tank (US version)

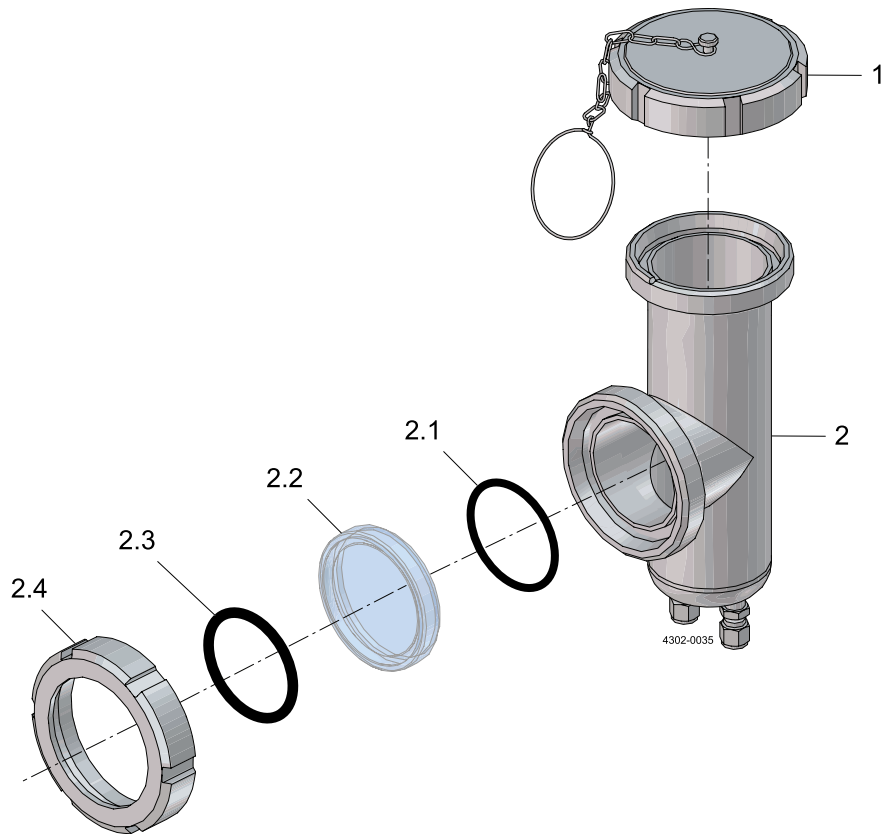

13 HPM M15 & HPM S15 (US version), spare parts and drawings

HPM-S15 - Hybrid Powder Mixer, complete (US version)

Parts list

Pos.	Qty	Denomination
1	1	End Cap
2	1	Flush Tank House
2.1	1	Seal
2.2	1	Sight glass
2.3	1	Seal
2.4	1	Nut, union

13 HPM M15 & HPM S15 (US version), spare parts and drawings

HPM-M15 & HPM-S15 - C-Ball Valve (US version)

13.6 HPM-M15 & HPM-S15 - C-Ball Valve (US version)

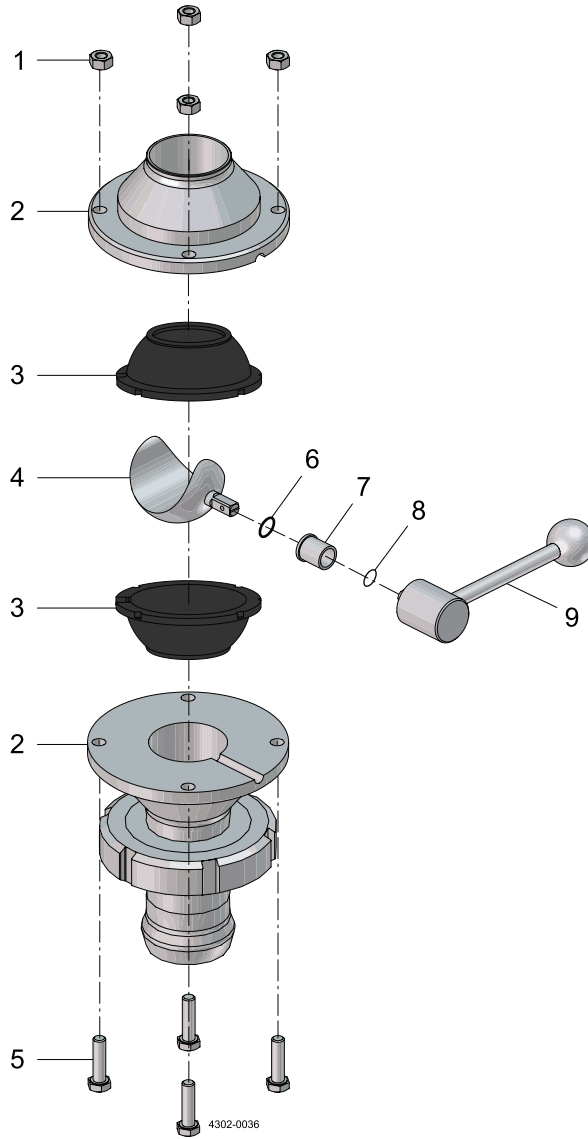

13 HPM M15 & HPM S15 (US version), spare parts and drawings

HPM-M15 & HPM-S15 - C-Ball Valve (US version)

Parts list

Pos.	Qty	Denomination
1	4	Nut
2	-	Housing complete
3 ♦	2	Seal
4	1	C-Ball w. shaft
5	4	Bolt
6 ♦	1	O-ring
7 ♦	1	Guide sleeve
8 ♦	1	Snap ring
9	1	Handle for C-Ball Valve

Service kits

Denomination

Service Kits & Service Valve

9614451701¹⁾

8010000839²⁾

8010004893³⁾

¹⁾ Parts marked with ♦ are included in the standard Service kit in FPM for C Ball valve: Item no. 9614451701

²⁾ Service Kit PTFE can be used for special applications where the Service Kit FPM does not work properly: Item no. 8010000839

³⁾ Service Valve to replace C-Ball Valve in use while servicing it: Item no. 8010004893

NOTE

From and with serial number 50083 the Hybrid Powder Mixers were born with FPM Sealing. Before that it was PTFE sealing.

13 HPM M15 & HPM S15 (US version), spare parts and drawings

HPM-M15 & HPM-S15 - Injector (US version)

13.7 HPM-M15 & HPM-S15 - Injector (US version)

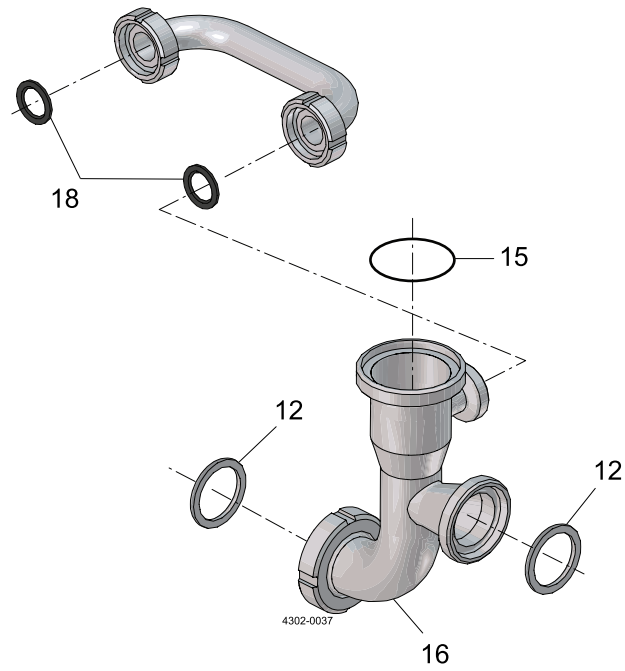

13 HPM M15 & HPM S15 (US version), spare parts and drawings

HPM-M15 & HPM-S15 - Injector (US version)

Parts list

Pos.	Qty	Denomination
12	2	Gasket
15	1	O-ring
16	1	Injector
18	2	Gasket

13 HPM M15 & HPM S15 (US version), spare parts and drawings

HPM-M15 & HPM-S15 - High Shear and Pump Unit (US version)

13.8 HPM-M15 & HPM-S15 - High Shear and Pump Unit (US version)

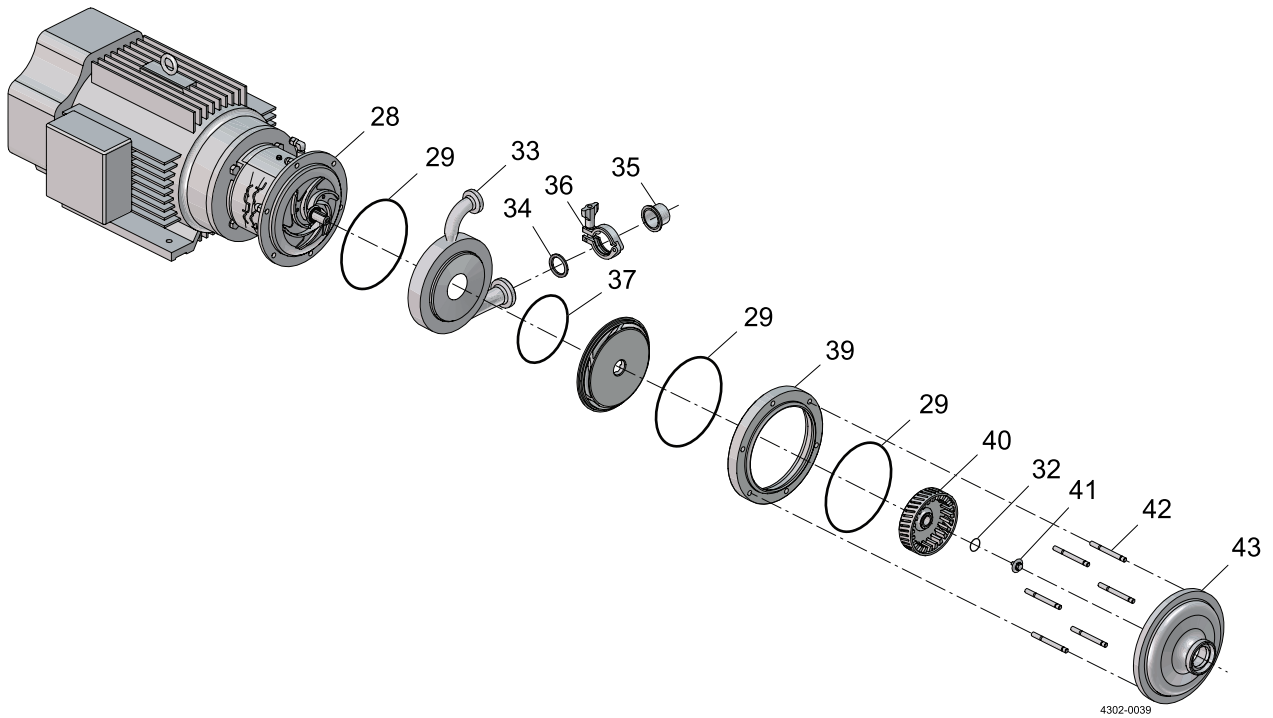

13 HPM M15 & HPM S15 (US version), spare parts and drawings

HPM-M15 & HPM-S15 - High Shear and Pump Unit (US version)

Parts list

Pos.	Qty	Denomination
28	1	Backplate
29 ◻↔	3	O-ring
32	2	O-ring
33	1	Pump Housing
34	1	Gasket
35	1	Ferrule
36	1	Clamp
37	1	O-ring
39	1	Flange
40	1	Rotor
41	1	Impeller Screw
42	6	Bolt
43	1	Pump Cover

Service kits

Denomination

Service Kits

9611922660¹⁾

9611922658²⁾

Please see parts list for LKH-112 in separate pump manual.

The parts above are either additional, revised or replaced by components of the LKH-112 pump except for the service kits.

¹⁾ Parts marked with ◻↔ are included in the Service Kit, FPM: 9611922660

²⁾ Parts marked with ● are included in the Service Kit, EPDM: 9611922658

See Annex, Operating instructions for frequency converter and pump.

15 General information

15.1 Service and repair

The seals (both stationary and mechanical) are the same as on the standard LKH-112 pump - please see separate Spare Part documentation for LKH 112 pump where the seal material reference is SiC/SiC, EPDM.

Be aware that there is an extra O-ring seal (ref. pos. 32 in Parts Drawing, High shear and pump unit) compared to the standard LKH 112 unit.

All other seals - please find item numbers in the individual parts lists.

15.2 Warranty

The warranty conditions are subject to the legal warranty period of 12 months from the date of delivery. In case of improper use, modifications of or damages to the device, we do not accept warranty claims. Damaged devices will also not be accepted. Furthermore, defects due to normal wear are not subject to warranty services.

15.3 How to contact Alfa Laval Kolding A/S

For further information please feel free to contact:

Alfa Laval Kolding A/S

31, Albuen - DK 6000 Kolding - Denmark

Registration number: 30938011

Tel switchboard: +45 79 32 22 00 - Fax switchboard: +45 79 32 25 80

www.toftejorg.com, www.alfalaval.dk - info.dk@alfalaval.com

Contact details for all countries are continually updated on our websites

How to contact Alfa Laval

Contact details for all countries are continually updated on our website.

Please visit www.alfalaval.com to access the information directly.

© Alfa Laval Corporate AB

This document and its contents is owned by Alfa Laval Corporate AB and protected by laws governing intellectual property and thereto related rights. It is the responsibility of the user of this document to comply with all applicable intellectual property laws. Without limiting any rights related to this document, no part of this document may be copied, reproduced or transmitted in any form or by any means (electronic, mechanical, photocopying, recording, or otherwise), or for any purpose, without the expressed permission of Alfa Laval Corporate AB. Alfa Laval Corporate AB will enforce its rights related to this document to the fullest extent of the law, including the seeking of criminal prosecution.