

Note that all unique customer requirements (i.e tolerance) need to be verified thru Alfa Laval.

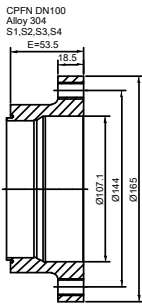
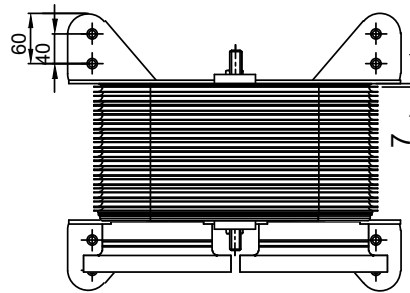
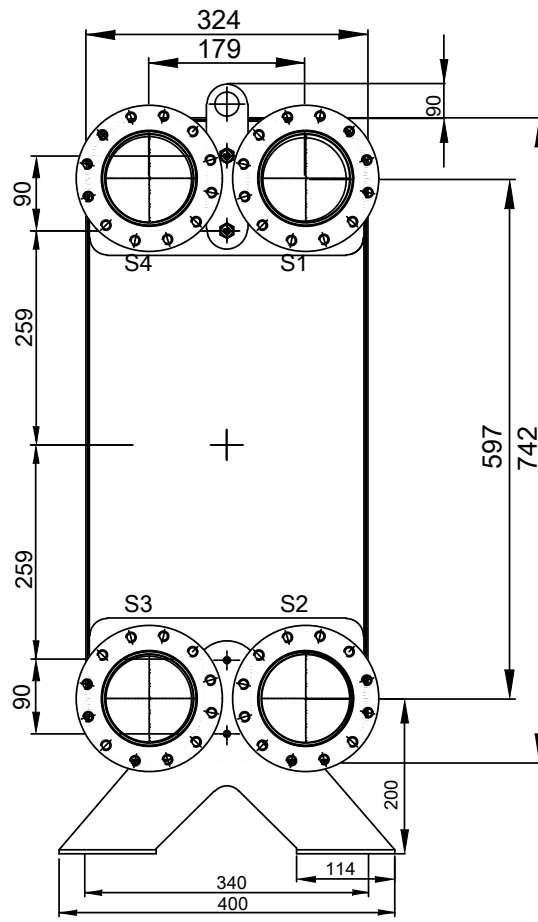
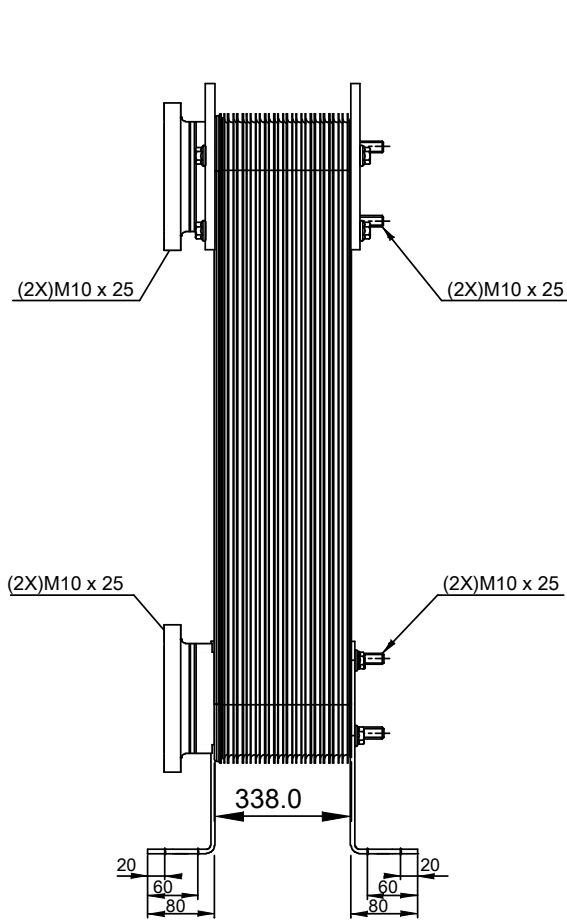

HEATING SURFACE
 NETWEIGHT 113.5 kg
 OPERATING WEIGHT kg
 PLATE MATERIAL ALLOY 316
 PLATE GROUPING 1*74ML/1*75MH

T1 T2 T3 T4 locations on back side correspond to S1 S2 S3 S4 on front side

ALL DIMENSIONS IN MILLIMETERS

SIDE	MEDIA	INLET	TEMP.	OUTLET	TEMP.	FLOW RATE	PRESSURE DROP	LIQUID VOL.
1		S1		S2				37.7 dm³
2		S3		S4				37.2 dm³

PRESSURE VESSEL APPROVAL

PED/UK



CB210-150M-F (3075023517)

www.alfalaval.com

CUSTOMER NAME / REF. NO.

TOTAL LENGTH 498.0 mm
 TOTAL WIDTH 324.0 mm
 TOTAL HEIGHT 959.0 mm

COMPANY / REF.



4/16/2024
 REV 0