

Alfa Laval LKHPF

Centrifugal pumps

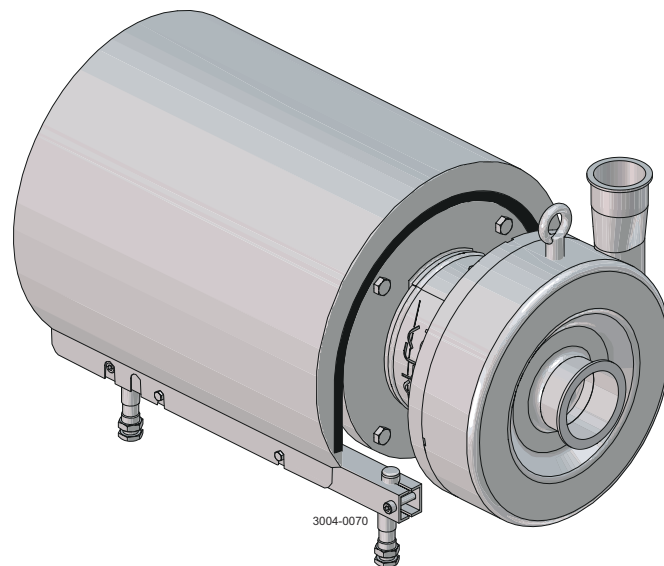

Lit. Code

200007905-2-EN-GB

Instruction Manual

Published by
Alfa Laval Kolding A/S
Albuen 31
DK-6000 Kolding, Denmark
+45 79 32 22 00

The original instructions are in English

© Alfa Laval AB 2026-05

This document and its contents are subject to copyrights and other intellectual property rights owned by Alfa Laval AB (publ) or any of its affiliates (jointly "Alfa Laval"). No part of this document may be copied, re-produced or transmitted in any form or by any means, or for any purpose, without Alfa Laval's prior express written permission. Information and services provided in this document are made as a benefit and service to the user, and no representations or warranties are made about the accuracy or suitability of this information and these services for any purpose. All rights are reserved.

Contents

1	Declarations of Conformity	5
1.1	EU Declaration of Conformity.....	5
1.2	UK Declaration of Conformity.....	6
2	Safety	7
2.1	Important Information.....	7
2.2	Safety Signs.....	8
2.3	Safety Precautions.....	10
2.4	Warning Signs in Text.....	15
2.5	Requirements of personnel.....	16
2.6	Recycling information.....	17
3	Introduction	19
4	Installation	21
4.1	Unpacking/Delivery.....	21
4.2	Installation.....	23
4.3	Pre-use Check.....	28
4.3.1	Pump with Impeller Screw.....	28
4.3.2	Pump without Impeller Screw.....	29
4.4	General Installation Guidelines.....	31
5	Operation	33
5.1	Operation/Control.....	33
5.2	Troubleshooting.....	35
5.3	Recommended Cleaning.....	36
5.3.1	Cleaning Information.....	37
6	Maintenance	39
6.1	General Maintenance.....	39
6.2	Cleaning Procedure.....	41
6.3	Dismantling of Pump/Shaft Seals.....	42
6.4	Assembly of Pump/Single Shaft Seal.....	46
6.5	Assembly of Pump/Flushed Shaft Seal.....	49
6.6	Adjustment of Shaft.....	52
7	Technical Data	55
7.1	Technical Data.....	55
7.2	Operating Data.....	56
7.3	Relubrication Intervals.....	56
7.4	Torque Specifications.....	57

7.5	Weight (kg).....	57
7.6	Noise Emission.....	58
8	Spare parts.....	59
8.1	Ordering spare parts.....	59
8.2	Alfa Laval service.....	59
8.3	Warranty - Definition.....	60
9	Parts lists and exploded views.....	61
9.1	LKHPF Filtration centrifugal pump for high inlet pressure.....	61
9.2	LKHPF - Wet end.....	62
9.3	LKHPF - Motor-dependent parts.....	63
9.4	LKHPF - Shaft seals.....	65

1 Declarations of Conformity

1.1 EU Declaration of Conformity

The designated company

Alfa Laval Kolding A/S, Albuen 31, DK-6000 Kolding, Denmark, +45 79 32 22 00

Company name, address and phone number

Hereby declare that

Pump

Designation

LKHPF-10, LKHPF-20, LKHPF-25, LKHPF-35, LKHPF-40, LKHPF-45, LKHPF-50, LKHPF-60, LKHPF-70

Type

AAB000000001-AAB999999999, AAX000000001-AAX999999999, 10.000-1.000.000, 100700000001-100799999999

Serial number

is in conformity with the following directives with amendments:

- Machinery Directive 2006/42/EC
- RoHS Directive 2011/65/EU and amendments

The person authorised to compile the technical file is the signer of this document.

Vice President BU Hygienic Fluid Handling

Head of Product Management

Title

Mikkel Nordkvist

Name

Kolding, Denmark

Place

2025-08-01

Date (YYYY-MM-DD)



Signature

DoC Revison_ 01_082025 / This Declaration of Conformity replaces Declaration of Conformity dated 2022-10-01



1.2 UK Declaration of Conformity

The designated company

Alfa Laval Kolding A/S, Albuen 31, DK-6000 Kolding, Denmark, +45 79 32 22 00

Company name, address and phone number

Hereby declare that

Pump

Designation

LKHPF-10, LKHPF-20, LKHPF-25, LKHPF-35, LKHPF-40, LKHPF-45, LKHPF-50, LKHPF-60, LKHPF-70

Type

AAB000000001-AAB999999999, AAX000000001-AAX999999999, 10.000-1.000.000, 100700000001-100799999999

Serial number

is in conformity with the following directives with amendments:

- The Supply of Machinery (Safety) Regulations 2008
- The Restriction of the Use of Certain Hazardous Substances in Electrical and Electronic Equipment Regulations 2012

Signed on behalf of: Alfa Laval Kolding A/S.

Vice President BU Hygienic Fluid Handling
Head of Product Management

Title

Mikkel Nordkvist

Name

Kolding, Denmark

Place

2025-08-01

Date (YYYY-MM-DD)





Signature

DoC Revison_ 03_082025



2 Safety

Read this first

 	<p>This Instruction Manual is designed for operators and service engineers working with the supplied Alfa Laval product.</p> <p>Operators must read and understand the Safety, Installation and Operating instructions of the supplied Alfa Laval product before carrying out any work or before you put the supplied Alfa Laval product into service!</p> <p>Not following the instructions can result in serious accidents.</p> <p>This documentation describes the authorized way to use the supplied Alfa Laval product. Alfa Laval will take no responsibility for injury or damage if the equipment is used in any other way.</p> <p>This Instruction Manual is designed to provide the user with the information to perform tasks safely for all phases in the lifetime of the supplied Alfa Laval product.</p> <p>The operator shall always read the chapter Safety first. Hereafter the operator can skip to the relevant section for the task to be carried out or for the information needed.</p> <p>Always read the chapter Technical Data thoroughly.</p> <p>This is the complete Instruction Manual for the supplied Alfa Laval product.</p>
--	--

NOTE

The illustrations and specifications in this Instruction Manual were effective at the date of printing. However, as continuous improvements are our policy, we reserve the right to alter or modify the Instruction Manual without prior notice or any obligation.

The English version of the Instruction Manual is the original manual. Alfa Laval cannot be held responsible for incorrect translations. In case of doubt, the English version applies.

2.1 Important Information

NOTE

Always read the manual before using the pump!

This Instruction Manual is designed to provide the user with the information to perform tasks safely for all phases in the life time of the product supplied.

The User shall **always** read the safety chapter first. Hereafter the User can skip to the relevant section for the task to be carried out or for the information needed.

This is the complete manual for the supplied product.

2.2 Safety Signs

Mandatory Action Signs

	General mandatory action sign.
	Refer to instruction manual.
	Use ear protection in noisy environments - noise protector.
	Use eye protection - safety glasses.
	Wear protective equipment - safety shoes.
	Use protective hand wear - safety gloves.
	Wear protective equipment - safety helmet.

Warning Signs

	General warning.
	Electricity.
	Transportation with forklift truck or other industrial vehicles if heavy.
	Heavy object lifting.
	Hot surface and burning danger.
	Sharp element.
	Crushing of hands.
	Corrosive substance.





2.3 Safety Precautions

All warnings in the manual are summarised on this page. Pay special attention to the instructions below so that severe personal injury and/or damage to the Supplied Alfa Laval Product is avoided.





General



	<p>Technical data must be observed during installation, operation and maintenance.</p> <p>All personnel should be informed about the technical data.</p> <p>The rules of Intended use are absolute. Use of the supplied Alfa Laval product is allowed only when in compliance with the technical data supplied with the Intended use.</p> <p>Differing utilisation, other than agreed with Alfa Laval Kolding A/S, exclude any liability and warranty.</p> <p>No modification or alteration of the supplied Alfa Laval product is allowed, unless explicit permission is granted by Alfa Laval Kolding A/S.</p>
---	---

Transportation and Lifting





  	<p>Never lift or elevate in any way other than described in this manual.</p> <p>Always use the original packaging or similar during transportation.</p> <p>Always ensure that personnel must have experience with lifting operations.</p> <p>Always transport the pump in its upright position.</p> <p>Always drain the pump head and accessories of any liquid.</p>
 	<p>Always ensure that the unit is securely fixed during transportation.</p> <p>Always ensure the lifting point to be in line with center of gravity. Adjust lifting point if necessary.</p> <p>Always use suitable transport device ie. forklift or pallet lifter.</p> <p>Always use appropriate lifting equipment for heavy parts when relevant.</p> <p>Always keep an eye on the load and stay clear during the lifting operation.</p>

Installation

	<p>If the local safety regulations prescribe that the installation has to be inspected and approved by responsible authorities before the supplied Alfa Laval product is put into service, consult with such authorities before installing the equipment and have the projected installation approved by them.</p> <p>Always read the <i>Technical Data</i> on page 55 thoroughly.</p> <p>Always check the pump before operation. See <i>Pre-use Check</i> on page 28.</p> <p>Check the direction of rotation of the impeller before operation. See the indication label on the pump.</p> <p>Always remove the impeller before checking the direction of rotation.</p> <p>Stay clear and ensure no one is near the shaft during test of rotation.</p> <p>Never start in the wrong direction of rotation with liquid in the pump.</p> <p>The large pump sizes are very heavy. Always use appropriate lifting equipment when handling the pump.</p> <p>Alfa Laval cannot be held responsible for incorrect unpacking.</p> <p>Alfa Laval cannot be held responsible for incorrect installation.</p> <p>Be aware that certain pump configurations can tilt, and therefore cause injuries to feet or fingers. The pump should be supported underneath the adaptor, when not installed in the process line.</p> <p>In case of shaft seal leakage, the media will drip from the slot in the bottom of the adaptor. In case of shaft seal leakage, Alfa Laval recommends putting a drip tray underneath the slot to collect the leakage.</p> <p>The 3A standard requires minimum clearance between the lowest part of the base, pump, motor or drive and for the floor to be no less than 100 mm / 4".</p> <p>The pump does not prevent back flow when intentionally or unintentionally stopped. If back flow can cause any hazardous situations, precautions must be taken e.g. a check valve can be installed in the system preventing hazardous situations.</p> <p>If the pump has been stored for longer period of time there is a risk that the seal faces may stick together and consequently cause damage to the seal at start-up. Please ensure that the pump shaft can be rotated by hand before start-up.</p>
	<p>Never start the pump if the impeller is fitted and the pump casing is removed.</p>
	<p>Always use a lifting crane when handling the pump.</p>
	<p>Always ensure all pipe lines (product, air, and water) are depressurized and emptied before installation, inspection, assembling and disassembling.</p>



	<p>Always have the pump electrically connected by authorised personnel. (See the motor instructions).</p> <p>Alfa Laval recommends the installation of a lockable repair breaker. If the repair breaker is to be used as an emergency stop, the colours of the repair breaker must be red and yellow.</p> <p>Alfa Laval recommends the supply disconnecting device shall be in accordance with EN60204-1. Always disconnect the supply disconnecting device safely after installation before continuing the installation.</p>
	<p>Always ensure the adaptor shield and motor fan guard are present and mounted correctly and allow no access to rotating parts before installing and starting the pump.</p>

Operation

	<p>Always read the <i>Technical Data</i> on page 55 thoroughly.</p> <p>Never run the pump when partially installed or not completely assembled.</p> <p>Necessary precautions must be taken if leakage occurs as this can lead to hazardous situations.</p> <p>Never use the pump for products not mentioned in the Alfa Laval pump selection program.</p> <p>The Alfa Laval pump selection program can be acquired from your local Alfa Laval sales company.</p> <p>Study the instructions carefully and pay special attention to the warnings!</p> <p>Alfa Laval cannot be held responsible for incorrect operation/control.</p> <p>The shaft seal must not run dry.</p> <p>Never throttle the inlet side.</p> <p>The supplied product is designed for cleaning in place (CIP). Use clean water free from chlorides.</p>
	<p>Never run the pump with both the suction side and the pressure side blocked.</p>
	<p>Never touch the supplied product or the pipelines when processing hot liquids or sterilizing.</p> <p>If pumps are sterilised using steam, standard 3A requires the process system to be designed to automatically shut down if the product pressure in the system becomes less than of the atmosphere and it cannot be started until the system is re-sterilised.</p>
	<p>Always follow the instructions in the safety data sheet for the cleaning agent.</p> <p>Always handle lye and acid with great care.</p> <p>The cleaning agents must be stored/disposed of in accordance with current regulations and directives.</p> <p>Always rinse well with clean water after the cleaning.</p>

Maintenance

	<p>In order to optimise the operation of the supplied Alfa Laval product and to minimize the down time due repair activities, the maintenance should consist of:</p> <ul style="list-style-type: none"> • Inspection and maintenance of the supplied Alfa Laval product: strictly follow the technical documentation • Preventive maintenance: visual inspection of the supplied Alfa Laval product followed by necessary adjustments and planned periodic replacement of wear and tear parts • Repairs: unscheduled break-down of a component, often causing the system to stop. Damaged components shall be replaced or repaired • Stock of Alfa Laval genuine spare parts: Alfa Laval recommend keeping a stock of genuine spare parts facilitating preventive maintenance and reducing down time in case of unplanned break-downs <p>Always read the <i>Technical Data</i> on page 55 thoroughly.</p> <p>Never service the pump if pressurised.</p> <p>Always use Alfa Laval genuine spare parts.</p> <p>Motors with grease nipples:</p> <p>Always lubricate according to motor manufactures recommended procedures.</p> <p>Always locate and remove grease vent plugs, if provided, prior to adding grease.</p> <p>Always check motor nameplate for grease type and lubrication intervals.</p> <p>Only use the grease type specified on the motor name plate.</p> <p>For Motor Maintenance, see motor instruction manual.</p> <p>Maintain the pump carefully.</p> <p>Study the instructions carefully and pay special attention to the warnings!</p> <p>Always keep spare shaft seals and rubber seals in stock.</p> <p>Check the pump for smooth operation after service.</p> <p>All scrap must be stored/disposed of in accordance with current regulations and directives.</p> <p>If the pump is supplied with FEP O-rings. Alfa Laval recommends that the casing O-ring is replaced during pump maintenance.</p> <p>If pump is not supplied with flush connections, the holes in the adaptor must be covered by the guard.</p>
---	--

	<p>Never service the pump when it is hot.</p>
	<p>Always disconnect the power supply when servicing the pump. Fit the electrical connections correctly if they have been removed from the motor during service.</p>
	<p>Always follow the instructions in the safety data sheets from the suppliers of cleaning agents, detergents, oils etc. Always follow the instructions in the safety data sheet for the cleaning agent.</p>

Storage



Alfa Laval recommend:

- Store the supplied Alfa Laval product as supplied in original packaging
- Port opening(s) should be protected against any ingress
- Bare steel (not stainless) should be lightly oiled/greased
- Store in a clean, dry place without direct sunlight or UV light
- Temperature range -5 °C to +40 °C / +23 °F to +104 °F
- Relative humidity less than 60%
- No exposure to corrosive substances (including contained air)

Noise



Under certain operating conditions, the supplied Alfa Laval product and/or the systems in which they are installed can produce high sound pressure levels. Appropriate noise protection measures should be taken when necessary and in accordance with local legislation.

Safety check



A visual inspection of any protective device (shield, guard, cover or other) on the supplied Alfa Laval product shall be carried out at least every 12 months. If the protective device is lost or damaged, especially when this leads to deterioration of safety performance, it shall be replaced. The fixing of the protective device should only be replaced with fixings of the same or an equivalent type.

Inspection acceptance criteria:

- It should not be possible to reach moving parts originally protected by a protective device
- The protective device must be securely mounted
- Ensure that screws for the protective device are securely tightened

Procedure in case of non-acceptance:

- Fix and/or replace the protective device

2.4 Warning Signs in Text

Pay attention to the safety instructions in this Instruction Manual.

Below are definitions of the four grades of warning signs used in the text where there is a risk for injury to personnel or damage to the supplied Alfa Laval product.



Indicates an imminently hazardous situation which, if not avoided, will result in death or serious injury.



Indicates a potentially hazardous situation which, if not avoided, could result in death or serious injury.



Indicates a potentially hazardous situation which, if not avoided, may result in minor or moderate damage to the supplied Alfa Laval product.



Indicates important information to simplify or clarify procedures.

2.5 Requirements of personnel

Operators

The operators shall read and understand this Instruction Manual.

Maintenance personnel

The maintenance personnel shall read and understand this Instruction Manual. The maintenance personnel or technicians shall be skilled within the field required to carry out the maintenance work safely.

Trainees

Trainees can perform tasks under the supervision of an experienced employee.

People in general

The public shall not have access to the supplied Alfa Laval product.

In some cases, specially skilled personnel may need to be hired (i.e. electricians, welders). In some cases the personnel has to be certified according to local regulations with experience of similar types of work.

2.6 Recycling information

Unpacking

Packing material may consist of wood, plastics, cardboard boxes and in some cases metal straps.



- Wood and cardboard boxes can be reused, recycled or used for energy recovery
- Plastics should be recycled or burnt at a licensed waste incineration plant
- Metal straps should be sent for material recycling

Maintenance

During maintenance, oil (if used) and wear parts in the supplied Alfa Laval product should be replaced.

- Oil and all non-metal wear parts must be disposed of in accordance with local regulations
- Rubber and plastics should be burnt at a licensed waste incineration plant. If not available they should be disposed of in accordance with local regulations
- Bearings and other metal parts should be sent to a licensed handler for material recycling
- Seal rings and friction linings should be disposed of to a licensed land fill site. Check your local regulations
- All metal parts should be sent for material recycling
- Worn out or defected electronic parts should be sent to a licensed handler for material recycling

Scrapping

At end of use, the equipment must be recycled in accordance with the relevant local regulations. Besides the equipment itself, any hazardous residues from the process liquid must be considered and dealt with in a proper manner. When in doubt, or in the absence of local regulations, please contact your local Alfa Laval sales company.

This page is intentionally left blank.

3 Introduction

The Alfa Laval LKHPF Centrifugal Pump for High Inlet Pressure is a high-pressure, high-efficiency centrifugal pump suited for high-pressure filtration applications. To increase process productivity, it is distinguished by high efficiency, low energy consumption, gentle product treatment, chemical resistance, and a wide range of flow rates, pressures and options.

Precision-engineered, the LKHP Filtration pump delivers greater energy efficiency than similar premium pumps. Its optimized design, premium motor, tight tolerances and advanced impeller design minimize recirculation and reduce energy consumption.

This page is intentionally left blank.

4 Installation

4.1 Unpacking/Delivery

⚠ WARNING

Be aware that certain pump configurations can tilt, and therefore cause injuries to feet or fingers. The pump should be supported underneath the adaptor, when not installed in the process line.

⚠ CAUTION

Alfa Laval cannot be held responsible for incorrect unpacking.

Always use a lifting crane when handling the pump.

! NOTE

The large pump sizes are very heavy. **Always** use appropriate lifting equipment when handling the pump.

Check the delivery for:

- Complete pump
- Delivery note
- Motor instructions

- 1 Remove any packing materials from the inlet and the outlet.

Avoid damaging the inlet and the outlet.

Avoid damaging the connections for flushing liquid, if supplied.

*) Remove packing materials!

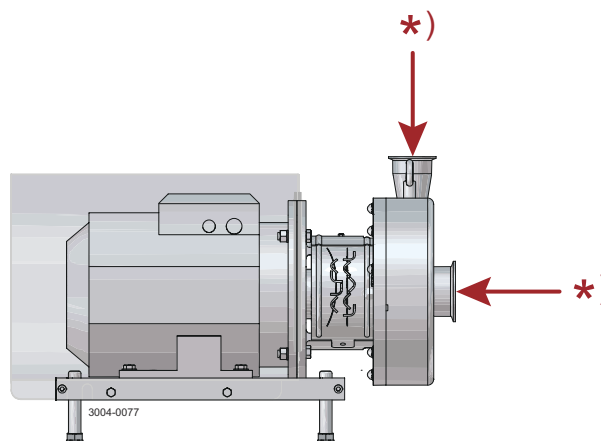

- 2 Inspect the pump for visible transport damage.

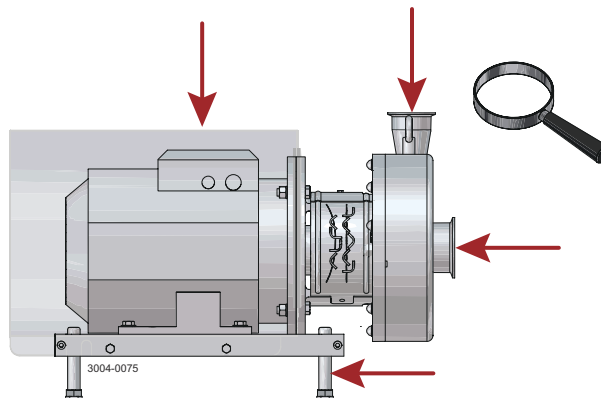

- 3 Always remove the shroud, if fitted, before lifting the pump.

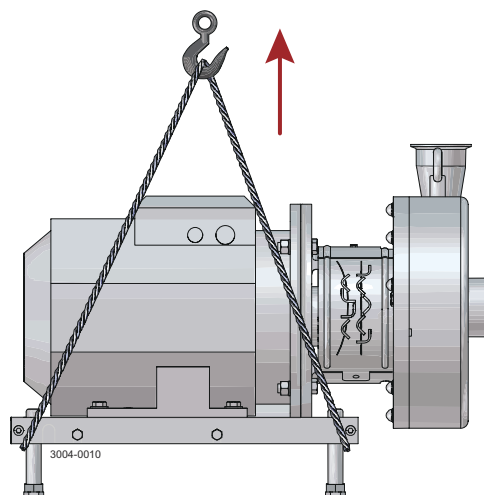

- 4 Do **NOT** use eyebolt in casing to lift the pump. The eyebolt is for casing removal only.

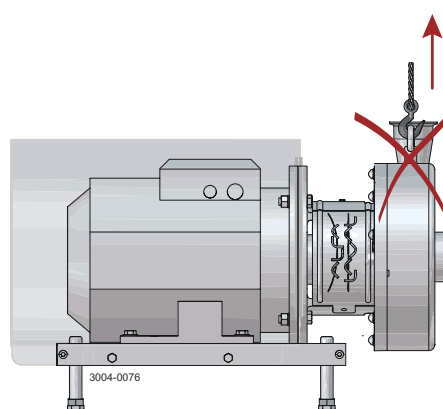

4.2 Installation

WARNING

Always have the pump electrically connected by authorised personnel. (See the motor instructions).

Alfa Laval recommends the installation of a lockable repair breaker. If the repair breaker is to be used as an emergency stop, the colours of the repair breaker must be red and yellow.

Alfa Laval recommends the supply disconnecting device shall be in accordance with EN60204-1. Always disconnect the supply disconnecting device safely after installation before continuing the installation.



CAUTION

Alfa Laval cannot be held responsible for incorrect installation.

Always use a lifting crane when handling the pump.

The pump does not prevent back flow when intentionally or unintentionally stopped. If back flow can cause any hazardous situations, precautions must be taken e.g. a check valve can be installed in the system preventing hazardous situations.

If the pump has been stored for longer period of time there is a risk that the seal faces may stick together and consequently cause damage to the seal at start-up. Please ensure that the pump shaft can be rotated by hand before start-up.

NOTE

Study the instructions carefully and pay special attention to the warnings!

Always read the [Technical Data](#) on page 55 thoroughly.

Always check the pump before operation. See [Pre-use Check](#) on page 28.

The large pump sizes are very heavy. **Always** use appropriate lifting equipment when handling the pump.

In case of shaft seal leakage, the media will drip from the slot in the bottom of the adaptor. In case of shaft seal leakage, Alfa Laval recommends putting a drip tray underneath the slot to collect the leakage.

- 1 Ensure at least 0.5 m /1.6' clearance around the pump.

Ensure the floor/frame is able to support the weight of the pump. See [Technical Data](#) on page 55.

Ensure the pump is supported by all four feet equally.

DO NOT fixate the motor and/or leg bracket to floor and/or frame.

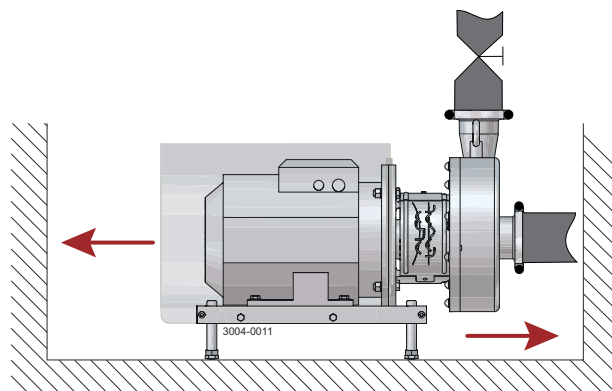

2 Check that the flow direction is correct.

O: Outlet

I: Inlet

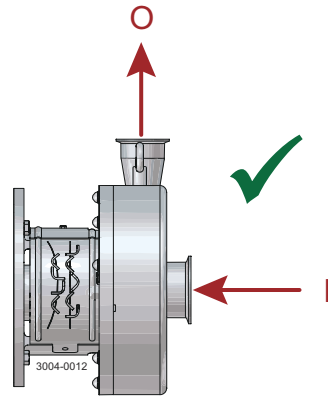

3 a) Ensure that the pipelines are routed correctly.

b) Ensure that the connections are tight.

c) Remember seal rings. Few bends.

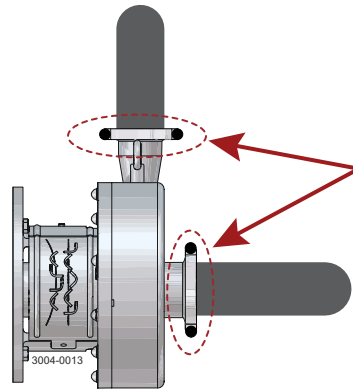

4 Avoid stress on the pump.

Piping system must be self-supported.

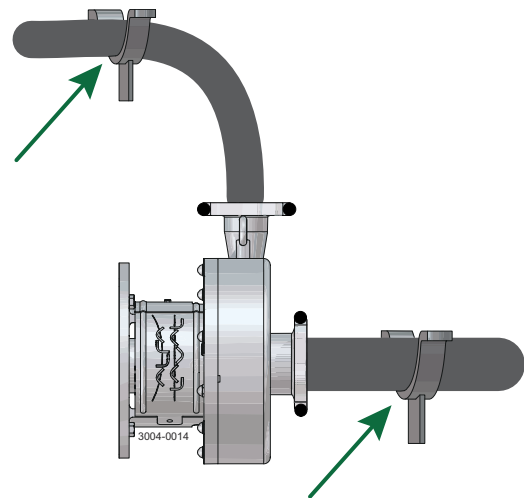

Pay special attention to:

- Vibrations
- Thermal expansion of the tubes
- Excessive welding
- Overloading of the pipelines

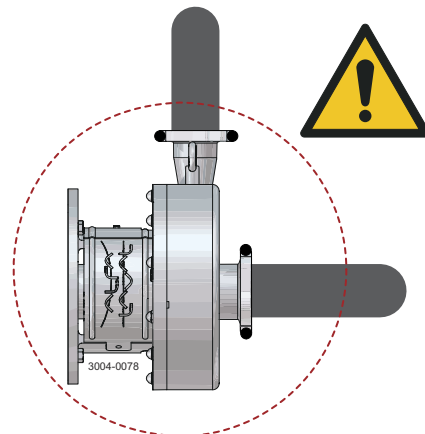

- 5 Ensure correct alignment of pump inlet and outlet with piping system.

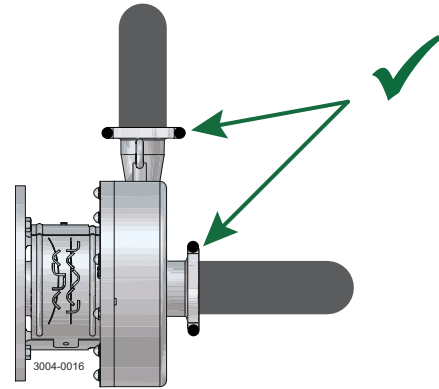

Alignment can be done by adjusting the pump legs.

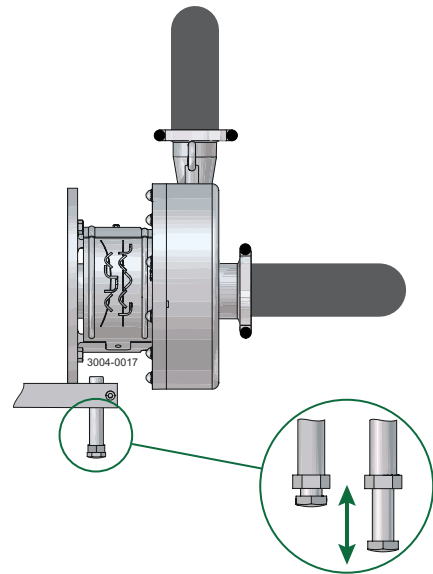

Centre of inlet and outlet to be aligned with centre of piping system.

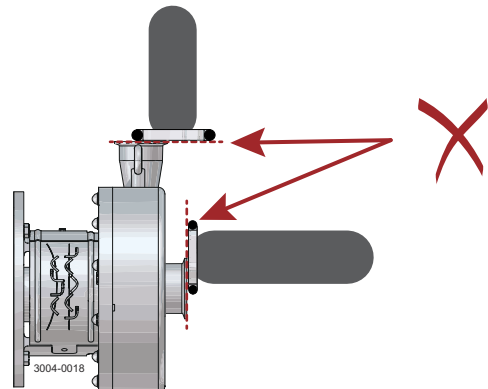

No gaps between connections on pump inlet and inlet pipe, and pump outlet and outlet pipe.

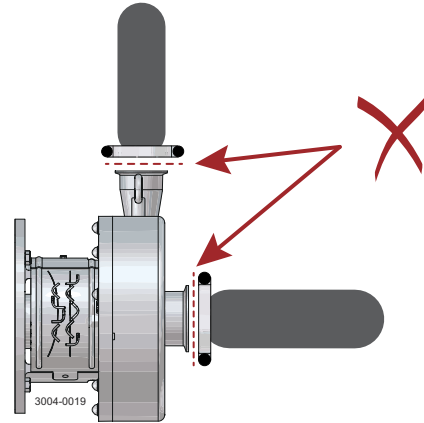

Angle between connections on pump inlet and inlet pipe, pump outlet and outlet pipe not allowed.

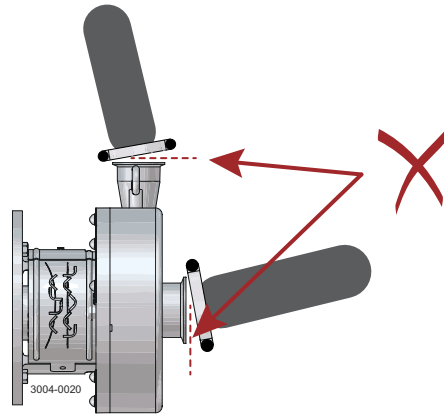

6 Ensure correct alignment of pump casing and pump backplate.

Angle not allowed.

Alignment can be done by adjusting the pump legs.

Ensure stud bolts in casing are aligned with holes in backplate.

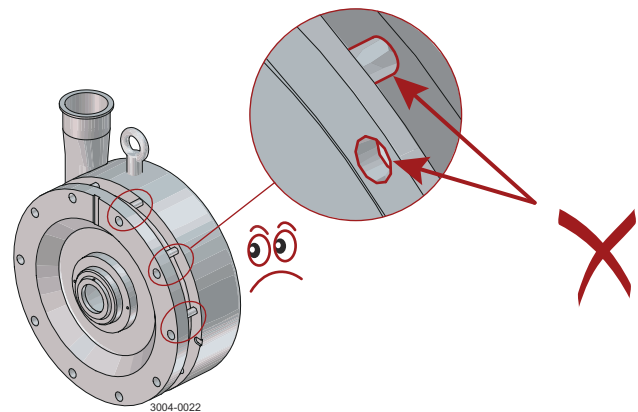
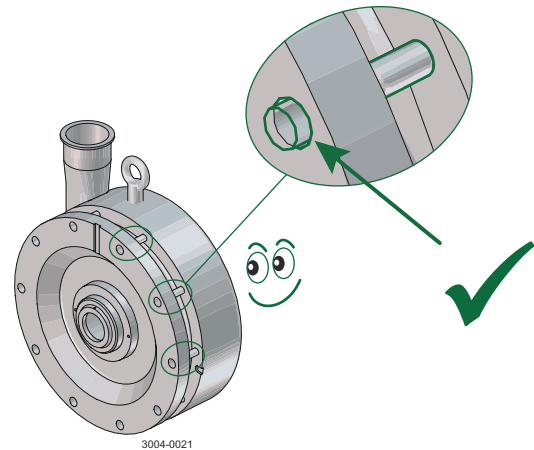

 **WARNING**

Always ensure the adaptor shield and motor fan guard are present and mounted correctly and allow no access to rotating parts before installing and starting the pump.

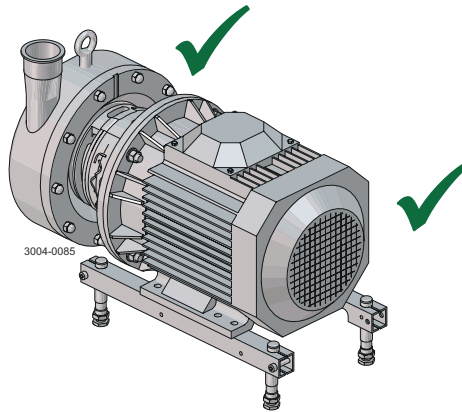

4.3 Pre-use Check

NOTE

Study the instructions carefully and pay special attention to the warnings!

Check the direction of rotation of the impeller before operation. See the indication label on the pump.

4.3.1 Pump with Impeller Screw

WARNING

Never start the pump if the impeller is fitted and the pump casing is removed.



CAUTION

Never start in the wrong direction of rotation with liquid in the pump.



- 1 a) Connect power supply.
- b) Start and stop the motor momentarily.
- c) Ensure that the direction of rotation of the motor fan is **clockwise** as viewed from the rear end of the motor.
- d) Disconnect power supply safely.

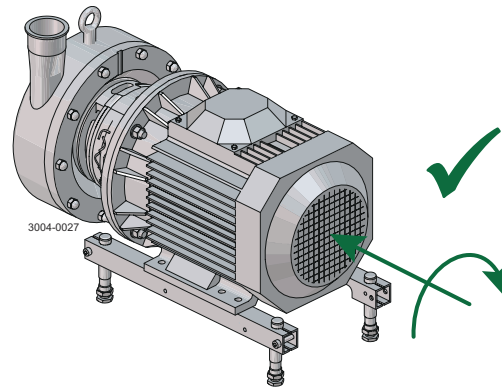

4.3.2 Pump without Impeller Screw

WARNING

Never start the pump if the impeller is fitted and the pump casing is removed.

**CAUTION**

Always remove the impeller before checking the direction of rotation.

- 1 a) Remove cap nuts (28), washers (29) and pump casing (45).
- b) Remove impeller (39) (see also the instruction in [Adjustment of Shaft](#) on page 52).

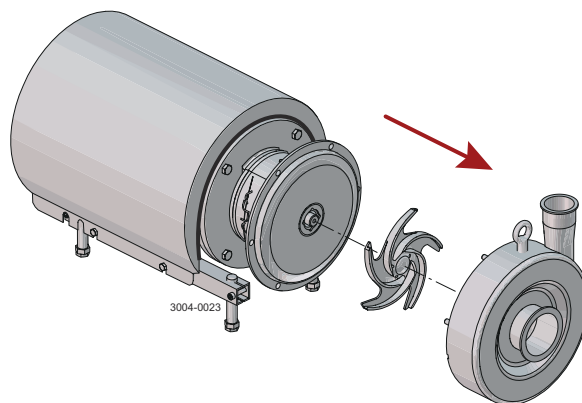

- 2 **WARNING**
Stay clear and ensure no one is near the shaft during test of rotation.

- a) Connect power supply.
- b) Start and stop the motor momentarily.
- c) Ensure that the direction of rotation of the stub shaft (7) is anticlockwise as viewed from the inlet side.
- d) Disconnect power supply safely.

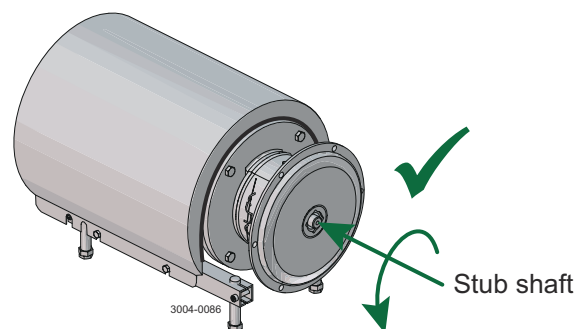

- 3 Fit and tighten impeller (39).

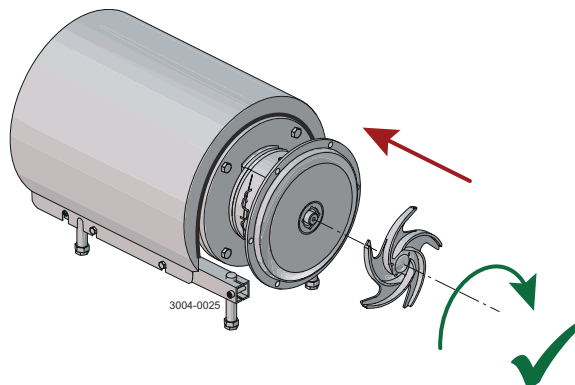

4

- a) Fit pump casing (45).
- b) Fit washers (29) and tighten cap nuts (28), according to torque values in *Torque Specifications* on page 57

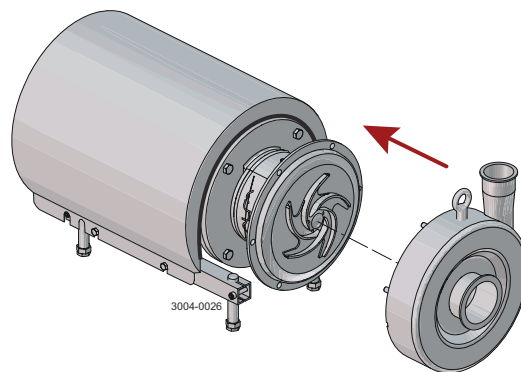

4.4 General Installation Guidelines

NOTE

When mounting the CM, it is important to achieve a solid mechanical connection between the equipment and the CM adapter plate. The CM can be mounted on surfaces up to 80 °C / 176 °F.

LKH guidelines

The CM is assembled on the top of the adapter.

Motor size	Tool Spanner Adapter screw	Tool Hex key CM screw	Max. torque Adapter screw / CM screw
IEC 80–280 NEMA 182–405	8 mm	4 mm	4.5 Nm / 8 Nm 3.3 ft-lb / 5.9 ft-lb

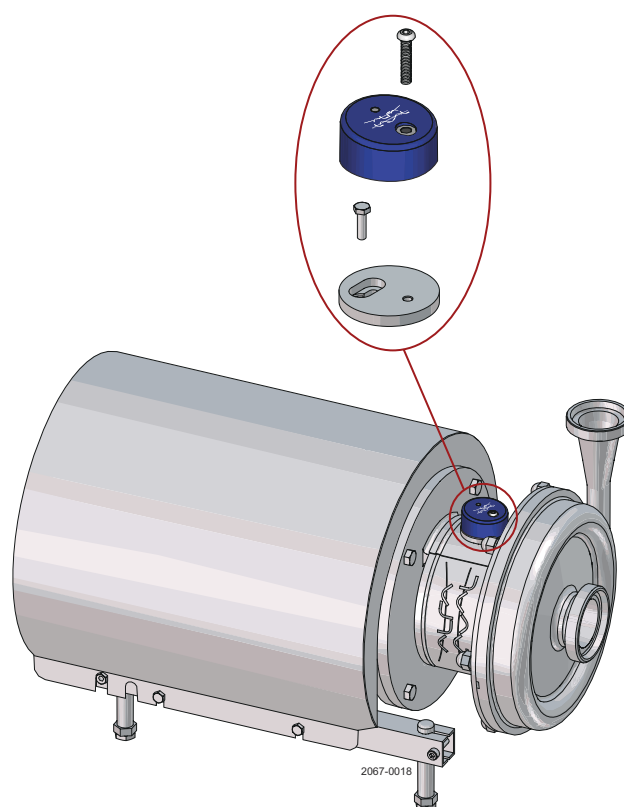

Hygienic recommendations

For a hygienic installation, use an FDA approved sealant between the equipment and the adapter plate, and between the CM and the adapter plate.

Adapter details

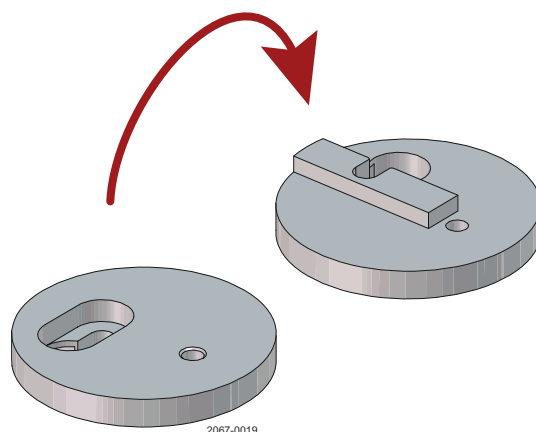

Kit Type / Article No. ¹	Screw Hex screw	Dimensions Ø / H	Weight
8010008558	M5 x 16	58 mm / 11 mm 2.3" / 0.43"	0.13 kg 0.29 lbs

¹ All adapters are made of stainless steel EN 1.4301 (AISI 304). The CM is included.

5 Operation

5.1 Operation/Control

NOTE

Study the instructions carefully and pay special attention to the warnings!

Always read the *Technical Data* on page 55 thoroughly.

DANGER Explosion danger!

Never run the pump with both the suction side and the pressure side blocked.

See the warning label!

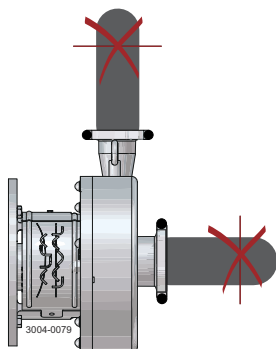

WARNING Burning risk!

Never touch the supplied product or the pipelines when processing hot liquids or sterilizing.

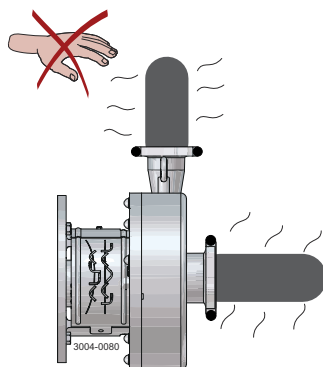

CAUTION

The shaft seal must not run dry.

Never throttle the inlet side.

*) **Do not allow to run dry**

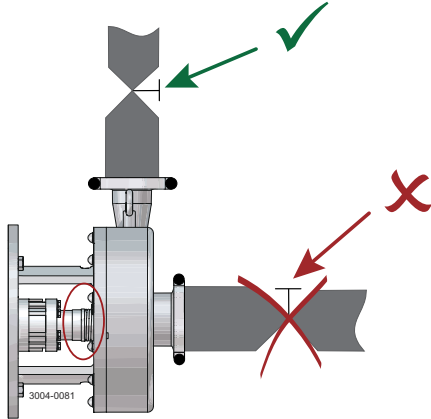

CAUTION

Alfa Laval cannot be held responsible for incorrect operation/control.

Flushed Shaft Seal

If equipped with Flushed Shaft Seal (FSS):

1. Connect the inlet of the flushing liquid correctly.
2. Regulate the water supply correctly.

Outlet T_{max} : 70 °C / 158 °F

P_{max} (FSS): 1 bar / 14.5 psi

O: Outlet

I: Inlet

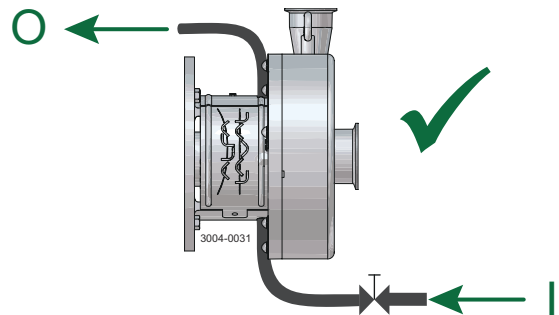

Control

Reduce the capacity and the power consumption by means of:

- *) Throttling the pressure side of the pump
- Reducing the impeller diameter
- Reducing the speed of the motor

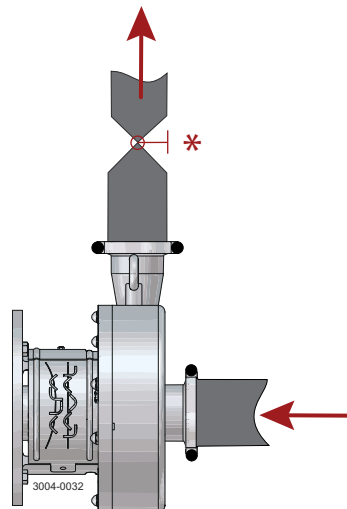

5.2 Troubleshooting

NOTE

Read the maintenance instructions carefully before replacing worn parts.

Problem	Cause/result	Remedy
Overloaded Motor.	Pumping of viscous liquids.	Larger motor or smaller impeller.
	Pumping of high density liquids.	
	Low outlet pressure (counter pressure).	Increase counter pressure (throttling).
	Lamination of precipitates from the liquid.	Frequent cleaning.
Cavitation: <ul style="list-style-type: none"> • Damage • Pressure reduction (sometimes to zero) • Increase in the noise level 	<ul style="list-style-type: none"> • Low inlet pressure • High liquid temperature 	<ul style="list-style-type: none"> • Increase the inlet pressure • Reduce the liquid temperature • Reduce the pressure drop before the pump • Reduce speed • $NPSH_A > NPSH_R$
Leaking shaft seal.	<ul style="list-style-type: none"> • Dry run • Incorrect rubber grade • Abrasive particles in the liquid 	Replace all wear parts. If necessary: <ul style="list-style-type: none"> • Change rubber grade • Change seal face material
Leaking O-ring seals.	<ul style="list-style-type: none"> • Incorrect rubber grade • Aged O-ring 	Change rubber grade. Change O-rings

5.3 Recommended Cleaning

⚠ WARNING Risk of burns!

Never touch the supplied product or the pipelines when sterilizing.



⚠ CAUTION

Always handle lye and acid with great care.



! NOTE

The supplied product is designed for cleaning in place (CIP).

NaOH = Caustic soda.

HNO₃ = Nitric acid.

The cleaning agents must be stored/disposed of in accordance with current regulations/directives.

Examples of cleaning agents

! NOTE

Use clean water free from chlorides.

Metric System

1. 1% by weight NaOH at 70°C

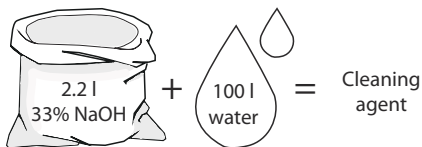
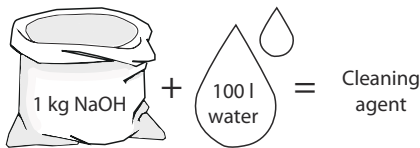

2. 0.5% by weight HNO₃ at 70°C

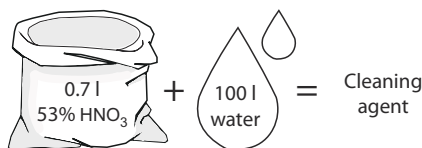

Imperial System

1. 1% by weight NaOH at 158°F

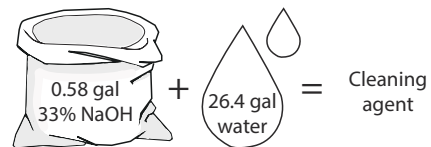
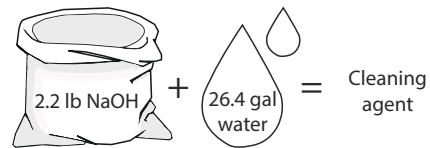

2. 0.5% by weight HNO₃ at 158°F

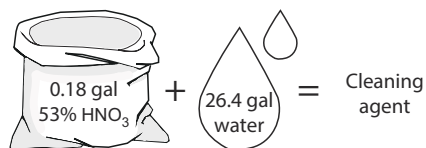

1. Avoid excessive concentration of the cleaning agent ⇒ **Dose gradually!**
2. Adjust the cleaning flow to the process
Milk sterilization/viscous liquids ⇒ Increase the cleaning flow!



Always rinse well with clean water after the cleaning.

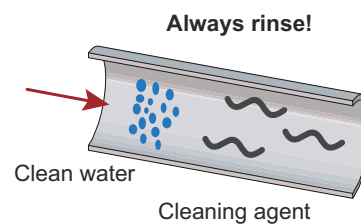

5.3.1 Cleaning Information



If pumps are sterilised using steam, standard 3A requires the process system to be designed to automatically shut down if the product pressure in the system becomes less than of the atmosphere and it cannot be started until the system is re-sterilised.

This page is intentionally left blank.

6 Maintenance

6.1 General Maintenance

NOTE

Maintain the pump carefully.

Study the instructions carefully and pay special attention to the warnings!

For motor maintenance, see motor instruction manual.

Always read the *Technical Data* on page 55 thoroughly.

Always keep spare shaft seals and rubber seals in stock.

Check the pump for smooth operation after service.

All scrap must be stored/disposed of in accordance with current regulations and directives.

DANGER

Never service the pump if pressurised.

*Atmospheric pressure required!

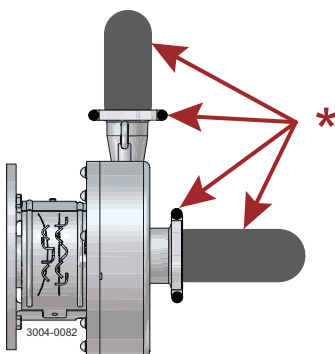

WARNING

Burning risk!

Never service the pump when it is hot.

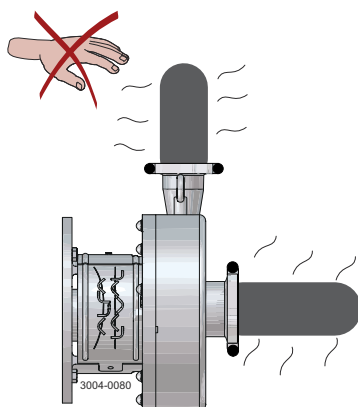



Always disconnect the power supply when servicing the pump.

Fit the electrical connections correctly if they have been removed from the motor during service.



	Shaft seal	Rubber seals	Motor bearings
Preventive maintenance	Replace after 12 months: (one-shift) Complete shaft seal.	Replace when replacing the shaft seal.	
Maintenance after leakage (leakage normally starts slowly)	Replace at the end of the day: Complete shaft seal.	Replace when replacing the shaft seal.	
Planned maintenance	<ul style="list-style-type: none"> Regular inspection for leakage and smooth operation Keep a record of the pump Use the statistics for planning of inspections Replace after leakage: Complete shaft seal.	Replace when replacing the shaft seal.	Yearly inspection is recommended <ul style="list-style-type: none"> Replace complete bearing if worn Ensure that the bearing is axially locked (See motor instructions)
Lubrication	Before fitting: Lubricate the O-rings with silicone grease or silicone oil.	Before fitting: Lubricate with silicone grease or silicone oil.	See information on motor name plate.

Pre-use Check

See [Pre-use Check](#) on page 28

6.2 Cleaning Procedure



Always follow the instructions in the safety data sheet for the cleaning agent.

Cleaning procedure for soiled impeller screw tapped hole

1. Remove stub shaft (7) as per section 4 of the Service Manual
2. Submerge and soak stub shaft for 5 minutes in COP tank with 2% caustic wash
3. Scrub the blind tapped impeller screw hole vigorously by plunging a clean 1/2" diameter sanitary bristle pipe brush in and out of the hole for two minutes while submerged
4. Soak Stub Shaft (7) in acid sanitiser for 5 minutes, then scrub blind tapped hole as described in step 3 above
5. Rinse well with clean water and blow-dry blind tapped hole with clean air
6. Swab test the inside of the tapped hole to determine cleanliness
7. Should the swab test fail, repeat steps 2 to 6 above until swab test is passed

Should swab testing continue to fail, or time is of the essence, install a new (spare) stub shaft (7).

6.3 Dismantling of Pump/Shaft Seals

NOTE

Study the instructions carefully and pay special attention to the warnings!

The items refer to *Parts lists and exploded views* on page 61.

- 1 Unscrew cap nuts (28) and remove washers (29) and pump casing (45).

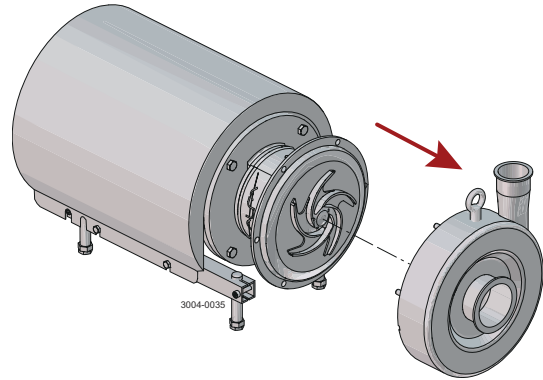

- 2 Remove screw (14) and safety guard (15).

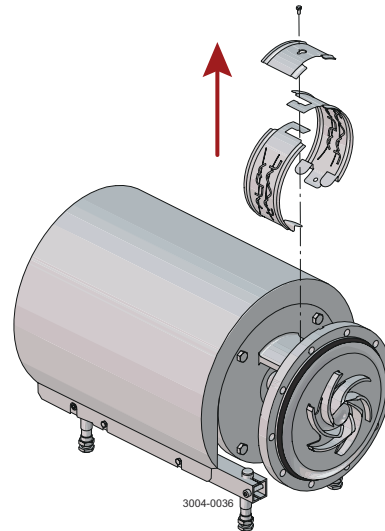

- 3 **Flushed shaft seal:**
Unscrew fittings (23) using a spanner.

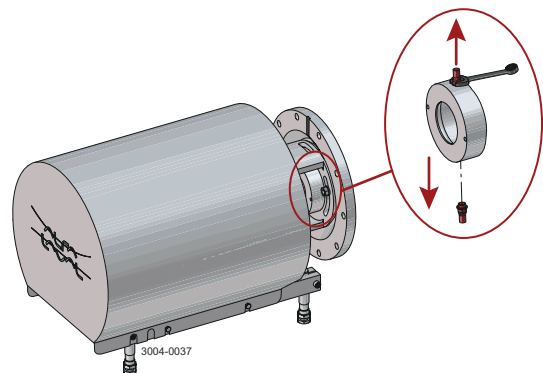

- 4**
- Remove impeller screw (41), if fitted, and pull off O-ring (42).
 - Remove impeller (39/40). If necessary, loosen the impeller by knocking gently on the impeller vanes.

* Counterhold with a screwdriver!

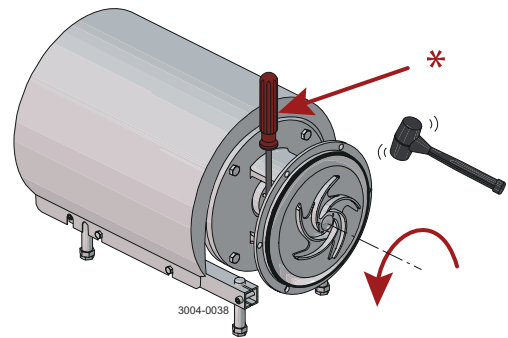

- 5** Pull out impeller (39/40) and the rotating part of the shaft seal.

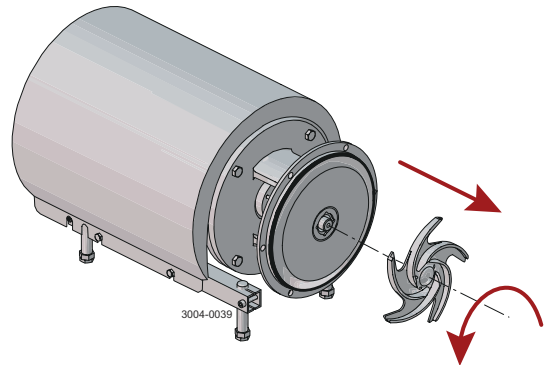

- 6** Remove space ring (33) and the rotating part of the shaft seal from impeller (39)/(40).

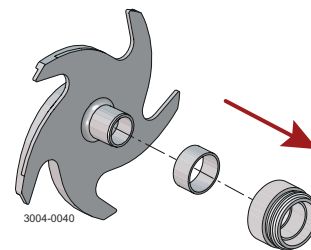

- 7** Separate rotating seal ring (34), quad rings (35, 38), support ring (36), guide ring (37) and washer (37) from rotating seal housing (37).

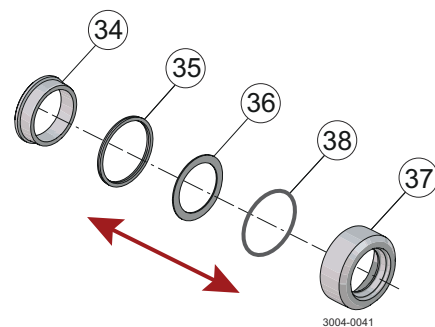

- 8
- a) Unscrew nuts (19) and remove washers (20) and back plate (30).
 - b) Pull off joint ring (43) from the back plate.

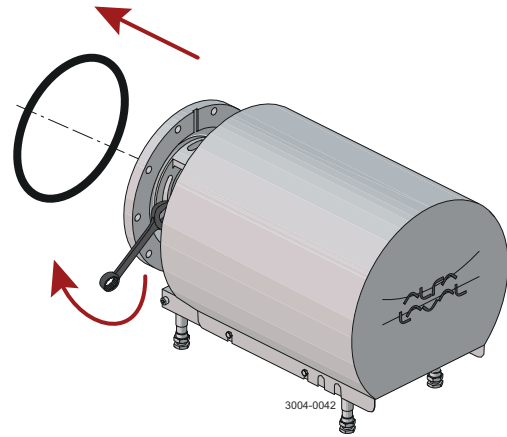

- 9
- a) Pull out stationary seal ring (32).
 - b) Remove O-ring (31) from the stationary seal ring.

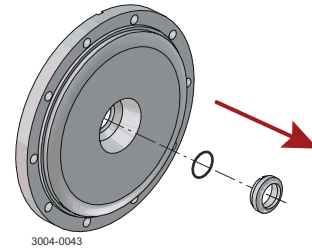

10 **Flushed shaft seal:**

- a) Remove screws (22) and seal housing (21).
- b) Pull out lip seal (24) and O-ring (26) from the seal housing.
- c) Slide off sleeve (27) from stub shaft (9).
- d) Remove O-ring (25) from the sleeve.

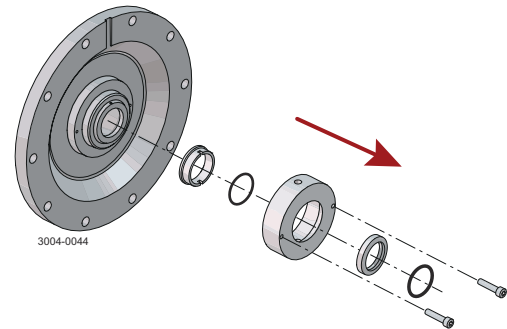

- 11
- a) Remove shroud (2).
 - b) Unscrew nuts (7) and remove washers (6), screws (18) and adaptor (17).

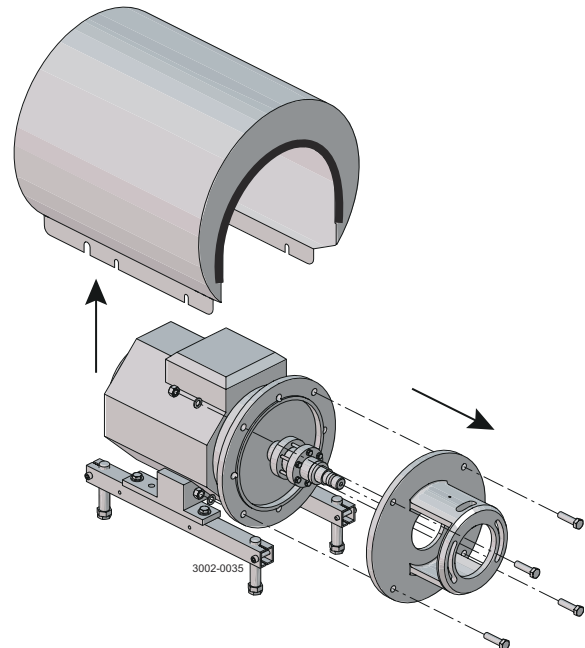

- 12**
- Loosen screws (13).
 - Slide off stub shaft (9) together with compression rings (12a+b).

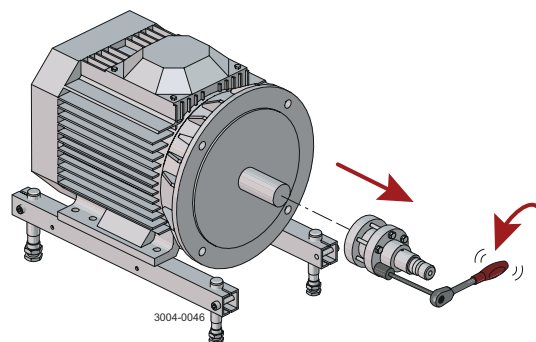

- 13**
- Separate screws (13), washers (13a) and compression rings (12a+b).

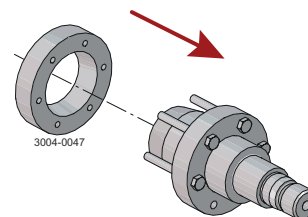

6.4 Assembly of Pump/Single Shaft Seal

NOTE

Study the instructions carefully and pay special attention to the warnings!
The items refer to *Parts lists and exploded views* on page 61.

NOTE

If change from double mechanical shaft seal to single shaft seal the shaft needs to be adjusted. See *Adjustment of Shaft* on page 52.

Seal ring:

LKHPF-10 to -60

Seal face (34) with squared notch is to be installed in rotating seal housing (37).

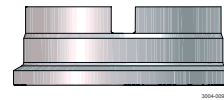

Seal face (32) with rounded bottom notch is to be installed in backplate (30).

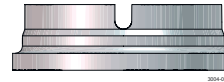

LKHPF-70

Seal face (34) with squared notch is to be installed in rotating seal housing (37).

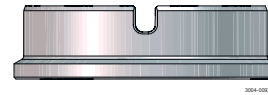

Only one notch in seal face (32) for backplate (30).

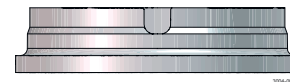

- 1 Assemble the rotating part of the shaft seal as shown above.

CAUTION

Ensure that the driver in the rotating seal housing enters the notch in the rotating seal ring.

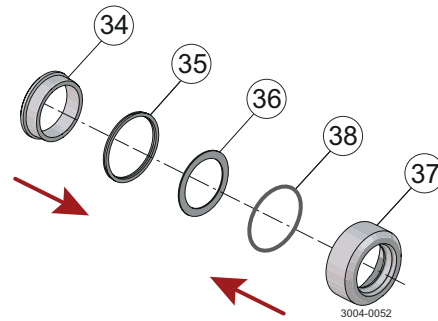

- 2
 - a) Lubricate impeller hub with silicone grease or oil.
 - b) Fit the rotating part of the shaft seal and space ring (33) on impeller (39/40).

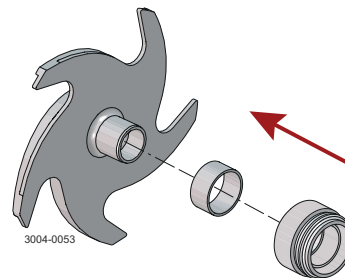

- 3
- Slide O-ring (31) onto stationary seal ring (32).
 - Press the stationary seal ring into back plate (30).

CAUTION

Ensure the two notch in the stationary seal ring enters into the two pins in the backplate.

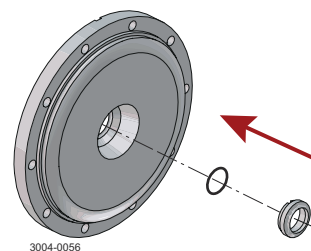

- 4
- Fit back plate (30), washers (20) and nuts (19) and tighten.

Tightening torques: See [Torque Specifications](#) on page 57.

- Fit O-ring (43) on the back plate.

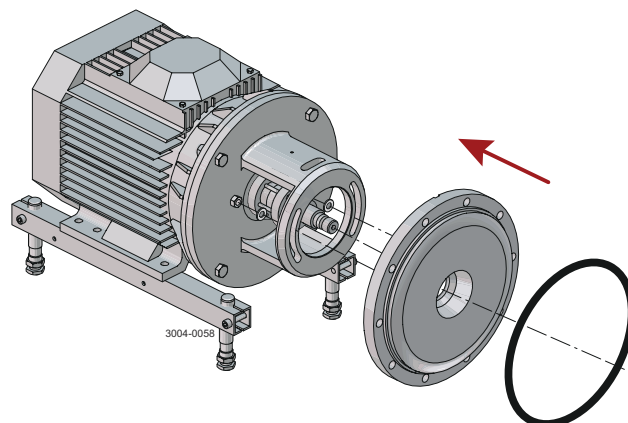

- 5
- Lubricate impeller hub (39) with silicone grease or oil.
 - Screw the impeller onto stub shaft (9).
 - If used, fit O-ring (42) and impeller screw (41).

Tightening torque for impeller screw: 20 Nm (14,8 lbf-ft)

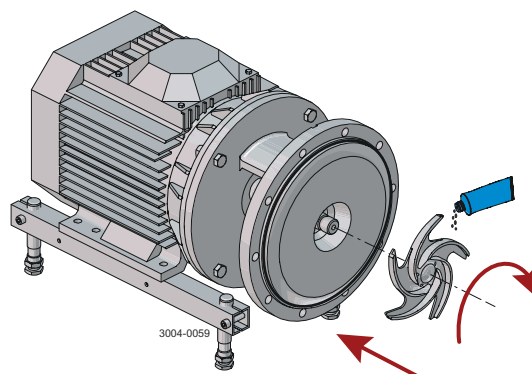

- 6
- Fit pump casing (45).
 - Fit washers (29) and cap nuts (28) and tighten.

NOTE

Cap nuts must be tightened according to the torque values specified in [Torque Specifications](#) on page 57.

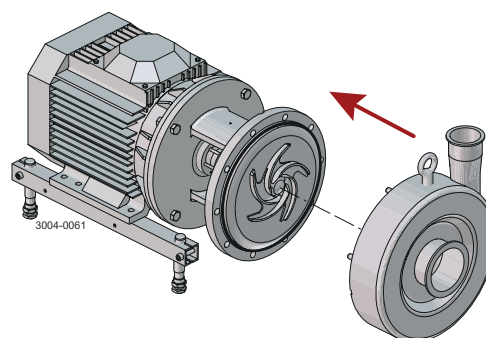

- 7
- a) Mount shroud (2).
 - b) Position safety guard (15) and screw (14) and tighten.

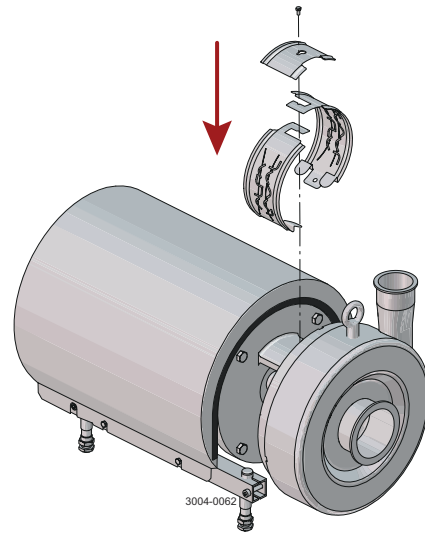

6.5 Assembly of Pump/Flushed Shaft Seal

NOTE

Study the instructions carefully and pay special attention to the warnings!

The items refer to *Parts lists and exploded views* on page 61.

NOTE

If change from double mechanical shaft seal to flushed shaft seal the shaft needs to be adjusted. See *Adjustment of Shaft* on page 52.

Seal ring:

LKHPF-10 to -60

Seal face (34) with squared notch is to be installed in rotating seal housing (37).

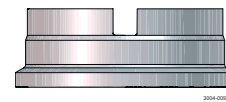

Seal face (32) with rounded bottom notch is to be installed in backplate (30).

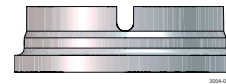

LKHPF-70

Seal face (34) with squared notch is to be installed in rotating seal housing (37).

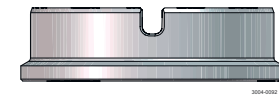

Only one notch in seal face (32) for backplate (30).

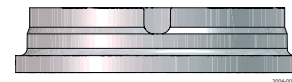

- 1 Assemble the rotating part of the shaft seal as shown above.

CAUTION

Ensure that the driver in the rotating seal housing enters the notch in the rotating seal ring.

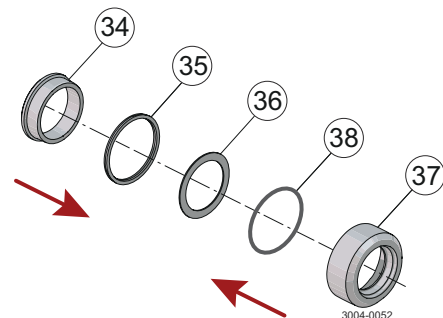

- 2
 - a) Lubricate impeller hub with silicone grease or oil.
 - b) Fit the rotating part of the shaft seal and space ring (33) on impeller (39/40).

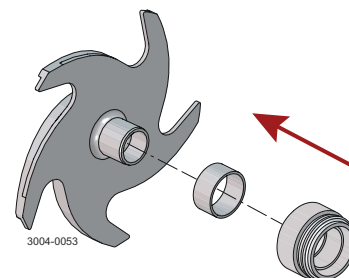

- 3 a) Slide O-ring (31) onto stationary seal ring (32).
 b) Press the stationary seal ring into back plate (30).



Ensure the two notch in the stationary seal ring enters into the two pins in the backplate.

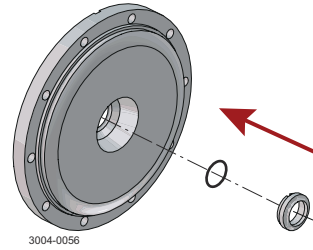

- 4 Fit lip seal (24) and O-ring (26) in seal housing (21).

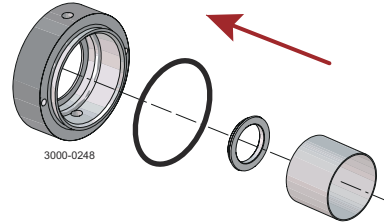

- 5 Fit the housing on back plate (30) and tighten the screws (22).

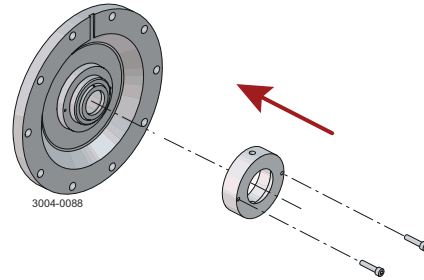

- 6 Slide sleeve (27) with O-ring (25) onto stub shaft (9).

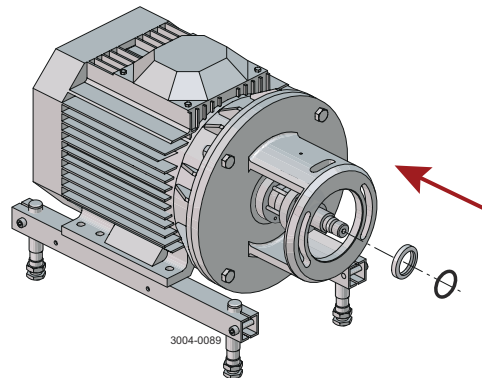

- 7 a) Fit back plate (30), washers (20) and nuts (19) and tighten.

Tightening torques: See [Torque Specifications](#) on page 57.

- b) Fit O-ring (43) on the back plate.

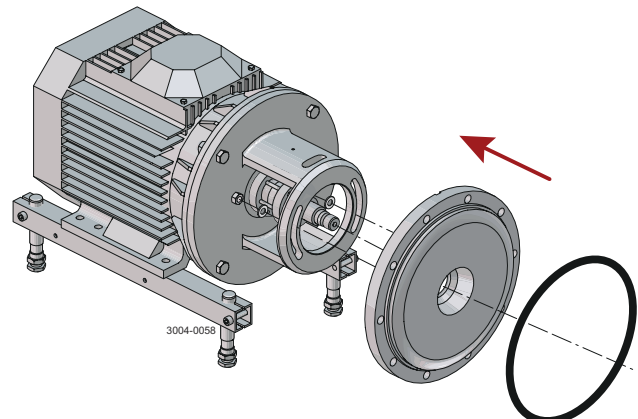

- 8
- Lubricate impeller hub (39) with silicone grease or oil.
 - Screw the impeller onto stub shaft (9).
 - If used, fit O-ring (42) and impeller screw (41).

Tightening torque for impeller screw: 20 Nm (14,8 lbf-ft)

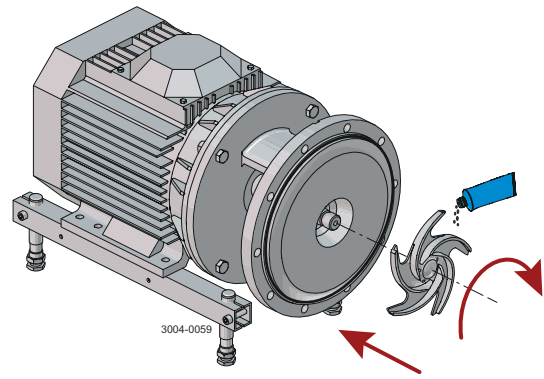

- 9
- Screw fittings (23) into seal housing (21).
 - Tighten with a spanner.

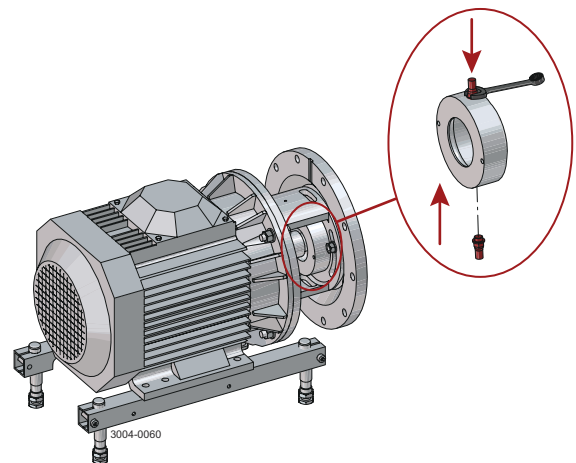

- 10
- Fit pump casing (45).
 - Fit washers (29) and cap nuts (28) and tighten.

NOTE

Cap nuts must be tightened according to the torque values specified in [Torque Specifications](#) on page 57.

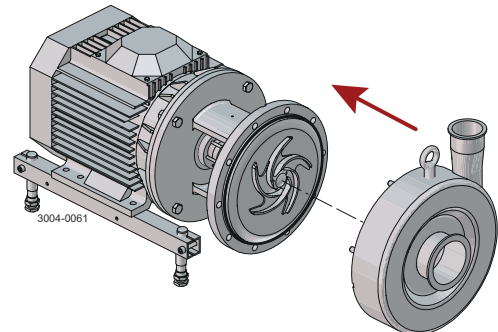

- 11
- Mount shroud (2).
 - Position safety guard (15) and screw (14) and tighten.

NOTE

If the pump is not supplied with flush connections, the holes in the adaptor must be covered by the guard.

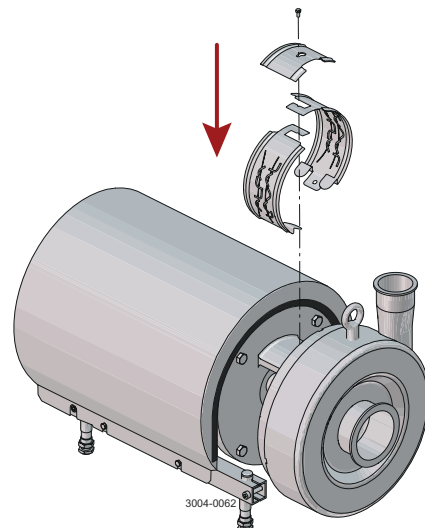

6.6 Adjustment of Shaft

NOTE

Study the instructions carefully and pay special attention to the warnings!

The items refer to *Parts lists and exploded views* on page 61.

For securing the best fixture to the motor shaft ensure the following:

- Conical surfaces on the pump shaft and compression rings are applied with grease
- No grease on the motor shaft
- No grease on the inside diameter of the pump shaft
- Screws for the compression rings are applied with grease

- 1 a) Remove shroud (2).
- b) Unscrew nuts (19) and remove washers (20), screws (18) and adapter (17).

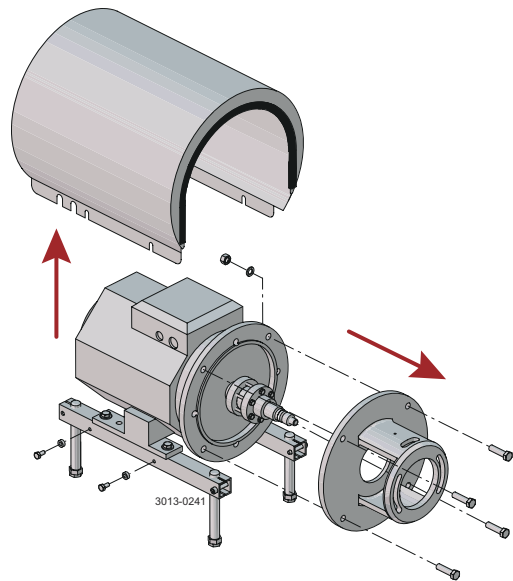

- 2 a) Loosen screws (13).
- b) Pull off stub shaft (9) together with compression rings (12a, 12b).

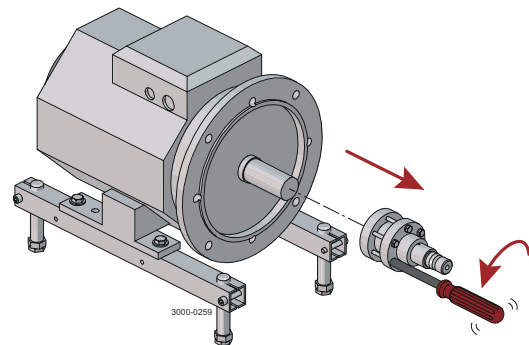

- 3 a) Push stub shaft (9) together with compression rins (12a, 12b) onto the motor shaft.

- b) Check that the clearance between the end of the stub shaft and the motor flange is 10-20 mm / 0.39-0.78".

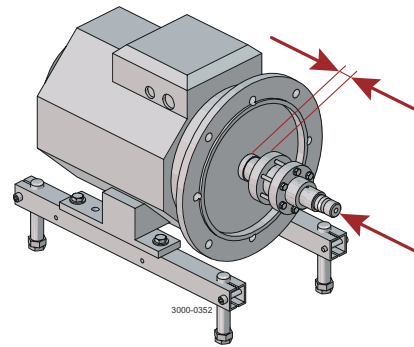

- 4 a) Tighten screws (13) lightly and evenly.

- b) Ensure that stub shaft (9) can be moved on the motor shaft.

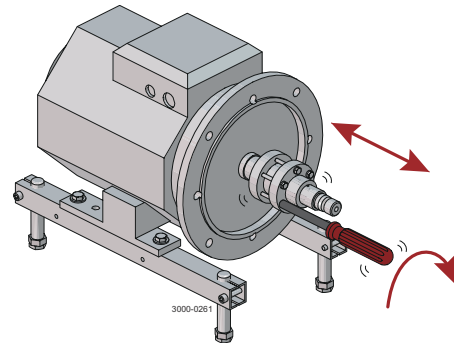

- 5 Fit adapter (17), screws (18), washers (20) and nuts (19), and tighten

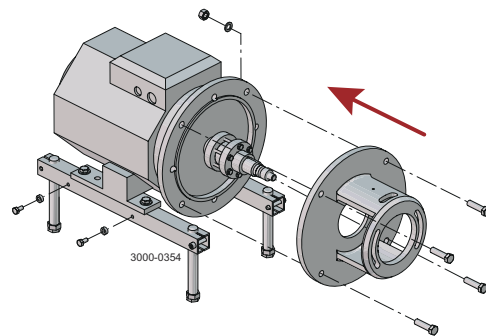

- 6 Fit back plate (30), washers (20) and nuts (19) and tighten according to [Torque Specifications](#) on page 57.

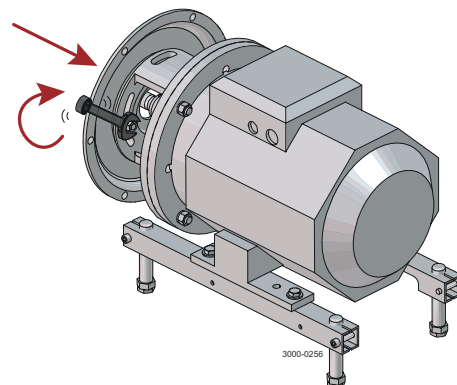

- 7
- Fit impeller (39) or (40) on stub shaft (9) by rotating clockwise.
 - Ensure that the clearance between the impeller and back plate (30) is 1.0 mm / 0.039".

! NOTE

The clearance can be adjusted by knocking gently with a plastic hammer.

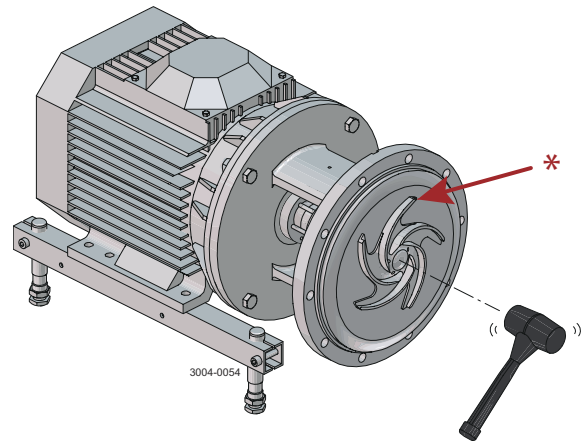

- 8
- Remove impeller (39) or (40) and back plate (30).
 - Tighten screws (13) evenly to 15 Nm (11 lbf-ft).

! NOTE

Tighten screws diagonally.

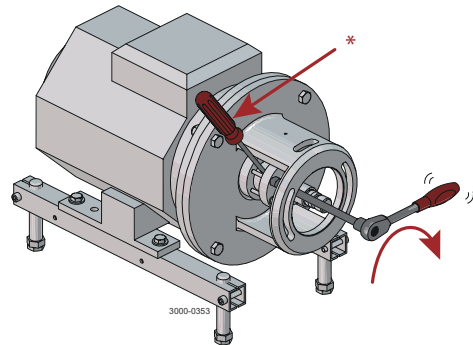

*Counterhold with a screwdriver.

7 Technical Data

NOTE

Technical data must be observed during installation, operation and maintenance.
All personnel should be informed about the technical data.

7.1 Technical Data

The LKHPF is a highly efficient and economical centrifugal pump, specially designed for high inlet pressure e.g. for use in filtration systems. The LKHPF pump meets the requirements of sanitary and gentle product treatment and chemical resistance.

LKHPF is available in the following sizes LKHPF-10, -20, -25, -35, -40, -45, -50, -60, -70.

Materials

Product wetted steel parts:	W. 1.4404 / AISI 316L
Other steel parts:	Stainless steel
Product wetted elastomers:	EPDM (standard) or Nitrile (NBR) and fluorinated rubber (FPM)
Other elastomers:	EPDM
Stationary seal ring:	Silicon Carbide
Rotating seal ring:	Silicon Carbide

Motor

IEC: Foot-flanged motor according to the IEC metric standard, 2 poles = 3000/3600 rpm at 50/60 Hz, IP 55 (with drain hole with labyrinth plug), insulation class F.

NEMA: Special high thrust bearing NEMA C-Face motor, foot mounted motor according to NEMA standards. 60 Hz. 3500 rpm. Premium efficiency, TEFC, insulation Class F.

Motor sizes

50 Hz:	2.2-75 kW
60 Hz:	2.5-80 kW
60 Hz:	3-100 Hp

Min./max. motor speed

2 poles: 2.2-45 kW:	3-60 Hp	900-4000 rpm
2 poles: 55-75 kW:	70-100 Hp	900-3600 rpm

7.2 Operating Data

Max. inlet pressure

LKHPF-10 to -70: 4000 kPa / 40 bar / 600 psi

Temperature

Temperature range: -10 °C to +140 °C / +14 °F to +284 °F (EPDM)

Flush media: Max. 70 °C / 158 °F

Viscosity

Maximum product viscosity: 800 cP

Flushed Shaft Seal

Water pressure inlet: Max. 1 bar / 14.5 psi

Water consumption: 0.25-0.5 l/min / 4-8 USGPH

Connections for Flushed Shaft Seal

LKHPF-10 to -70: Ø6 mm / Ø¼"

7.3 Relubrication Intervals

For recommended general maintenance follow the recommendations in the motor instruction manual.

NOTE

Always lubricate according to motor manufactures recommended procedures.

Always locate and remove grease vent plugs, if provided, prior to adding grease.

Always check motor nameplate for grease type and lubrication intervals.

For further information contact your local Alfa Laval Technical Support.

CAUTION

Only use the grease type specified on the motor name plate.

7.4 Torque Specifications

! NOTE

The table below specifies the tightening torques for the screws, bolts and nuts in this pump.

Always use the torques specified below if no other values are shown. This may affect personal safety.

Size	Tightening torque	
	Nm	lbf-ft
M8	20	15
M10	40	30
M12	67	49
M14	110	81

7.5 Weight (kg)

! NOTE

Weight can vary depending of configuration. Weight is only to be seen as a reference value during handling, transporting and packaging.

Pump Type: LKHPF

Size	Motor												
	90	112	132		160			180	200			250	
	2.2 kW	4 kW	5.5 kW	7.5 kW	11 kW	15 kW	18.5 kW	22 kW	30 kW	37 kW	45 kW	55 kW	75 kW
10	64	84											
20	68	88	105	119									
25		101	118	132	191	205							
35		101	119	133	192	206							
40				132	192	206	224	242					
45		103	120	134	194	208							
50			118	132	191	205	223	242					
60			120	134	193	207	225	244	352				
70			156	170	214	228	246	277	384	399	415	541	576

7.6 Noise Emission

Pump Type	Sound pressure level (dBA)
LKH-5	60
LKH-10	69
LKH-15	72
LKH-20	70
LKH-25	74
LKH-35	71
LKH-40	75
LKH-45	70
LKH-50	75
LKH-60	77
LKH-70	88
LKH-75	79
LKH-85	86
LKH-90	75
LKH Prime 10	69
LKH Prime 20	74
LKH Prime 40	77
LKH-112	70
LKH-113	69
LKH-114	68
LKH-122	75
LKH-123	77
LKH-124	80

Pump Type	Sound pressure level (dBA)
SolidC-1	68
SolidC-2	72
SolidC-3	73
SolidC-4	72
MR-166	76
MR-185	82
MR-200	81
MR-300	82
GM	54
FM-OS	61

The above LKH noise levels are the same for LKHPPF, LKHI, LKH UltraPure, LKH Evap and LKHex.

The above LKH Prime is the same for LKH Prime UltraPure, LKHex Prime and LKHex Prime UltraPure.

The above SolidC noise levels are the same for SolidC UltraPure.

The noise measurements have been carried out with the original motor and shroud, approximately at the Best Efficiency Point (BEP) with water at ambient temperature and at 50Hz.

Often the noise level generated by the flow through the process system (eg. valves, pipes, tanks etc.) is much higher than that generated by the pump itself. Therefore it is important to consider the noise level from the whole system and take the necessary precautions with regard to personal safety, if required.

8 Spare parts

For every delivered Alfa Laval Product, a spare part list is available.

This spare part list contains a range of the most common wear parts for the machinery. If any component not mentioned is required, please contact your local Alfa Laval representative for availability.

You can find our spare part catalogue at <https://hygienicfluidhandling-catalogue.alfalaval.com>.

Always use Alfa Laval genuine spare parts. The warranty of Alfa Laval products is dependent on use of Alfa Laval genuine spare parts.

8.1 Ordering spare parts

When ordering spare parts, please always state:

1. Serial number (if available)
2. Item number/spare part number (if available)
3. Capacity or other relevant identification

8.2 Alfa Laval service

Alfa Laval is represented in all larger countries of the world.

Do not hesitate to contact your local Alfa Laval representative, with any questions or requirement of spare parts for Alfa Laval equipment.

8.3 Warranty - Definition



The rules of Intended use are absolute. Use of the supplied Alfa Laval product is allowed only when in compliance with the technical data supplied with the Intended use.

Differing utilisation, other than agreed with Alfa Laval Kolding A/S, exclude any liability and warranty.

No modification or alteration of the supplied Alfa Laval product is allowed, unless explicit permission is granted by Alfa Laval Kolding A/S.



Liability and warranty are excluded:

- If advice and instruction of operating instructions are ignored
- For incorrect operation or for insufficient maintenance of the supplied Alfa Laval product
- For any kind of change of function of the supplied Alfa Laval product without prior written agreement by Alfa Laval Kolding A/S
- If supplied Alfa Laval product is modified by non-authorized persons
- If using the supplied Alfa Laval product without attention of appropriate safety regulations, (see [Safety](#) on page 7)
- If protection equipment is not used and vessel process / ancillary equipment is not brought to a standstill
- If the supplied Alfa Laval product and ancillary parts are not properly maintained (to be executed in intervals and including fitting of prescribed replacement parts)

When exchanging parts, only original replacement parts, released from the manufacturer, must be used.

9 Parts lists and exploded views

9.1 LKHPF Filtration centrifugal pump for high inlet pressure

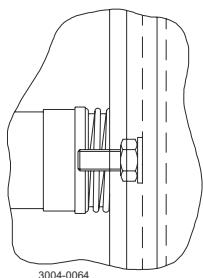
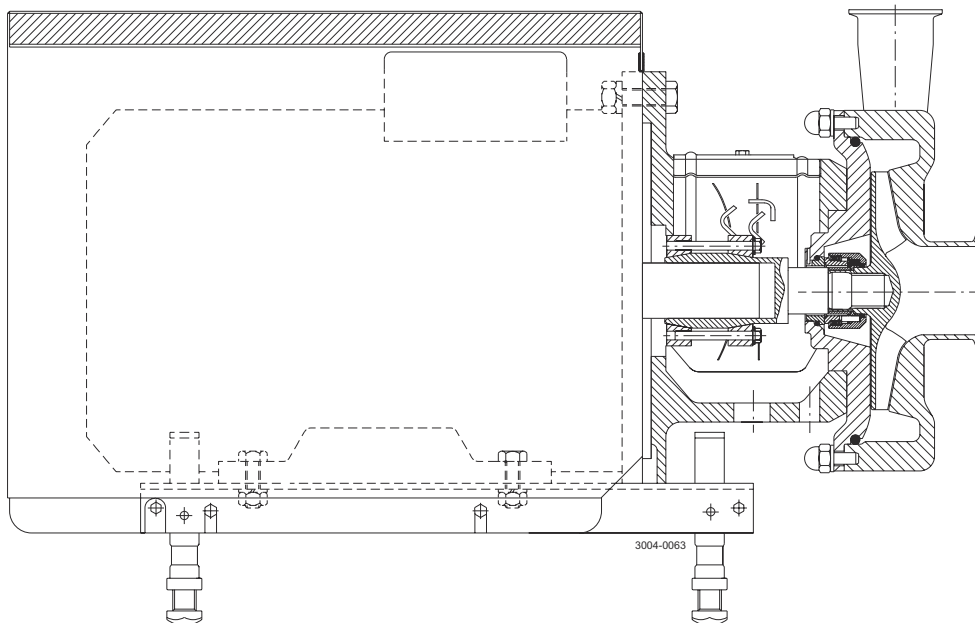

Mounting of back plate to adaptor

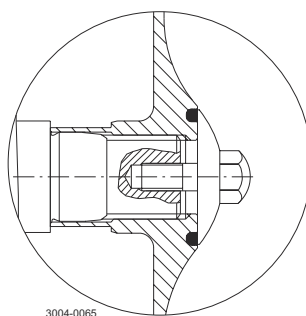

Impeller screw

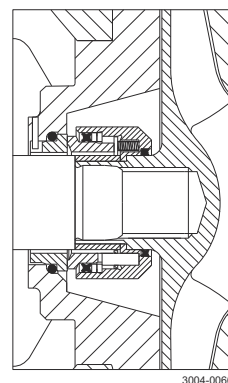

Single shaft seal

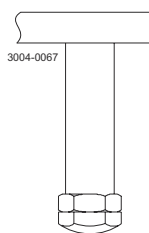

Mounting of legs
55-75 kW

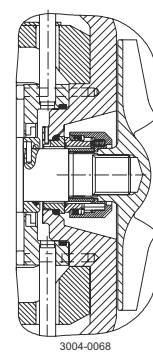

Flushed shaft seal

9.2 LKHPF - Wet end

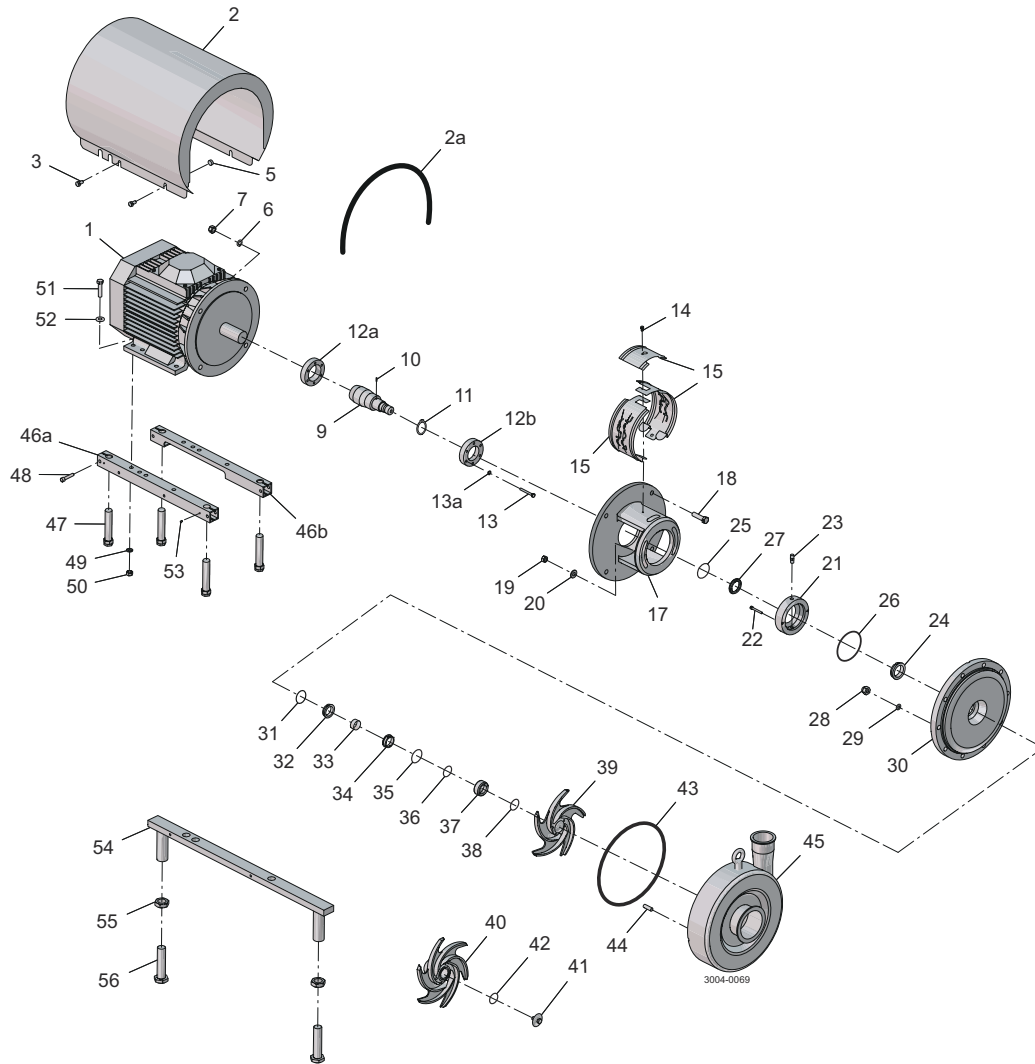

Pos.	Qty.	Denomination
19	2	Nut
20	2	Washer
28	10	Cap nut
29	10	Washer
39	1	Impeller
40	1	Impeller for impeller screw

Pos.	Qty.	Denomination
41	1	Impeller screw
42	1	O-ring
43	1	O-ring
44	10	Bolt
45	1	Pump casing compl.

Pos.	Qty.	Denomination
1	1	Motor ABB
2	1	Shroud
3	4	Screw
5	4	Distance sleeve
6	4	Washer for adaptor
7	4	Nut for adaptor
9	1	Shaft incl. pin
10	1	Connex pin
11	1	Retaining ring
12a	1	Compression ring with thread
12b	1	Compression ring without thread
13	6	Screw
13a	6	Washer
14	1	Screw for safety guard
15	1	Safety guard set

Pos.	Qty.	Denomination
17	1	Adaptor
18	4	Screw for adaptor
46a	1	Support bar
46b	1	Support bar
47	4	Leg
48	4	Screw
49	4	Spring washer
50	4	Nut
51	4	Screw
52	4	Washer
53	4	Pivot screw
54	2	Leg bracket
55	4	Nut for leg
56	4	Screw for leg

9.4 LKHPF - Shaft seals

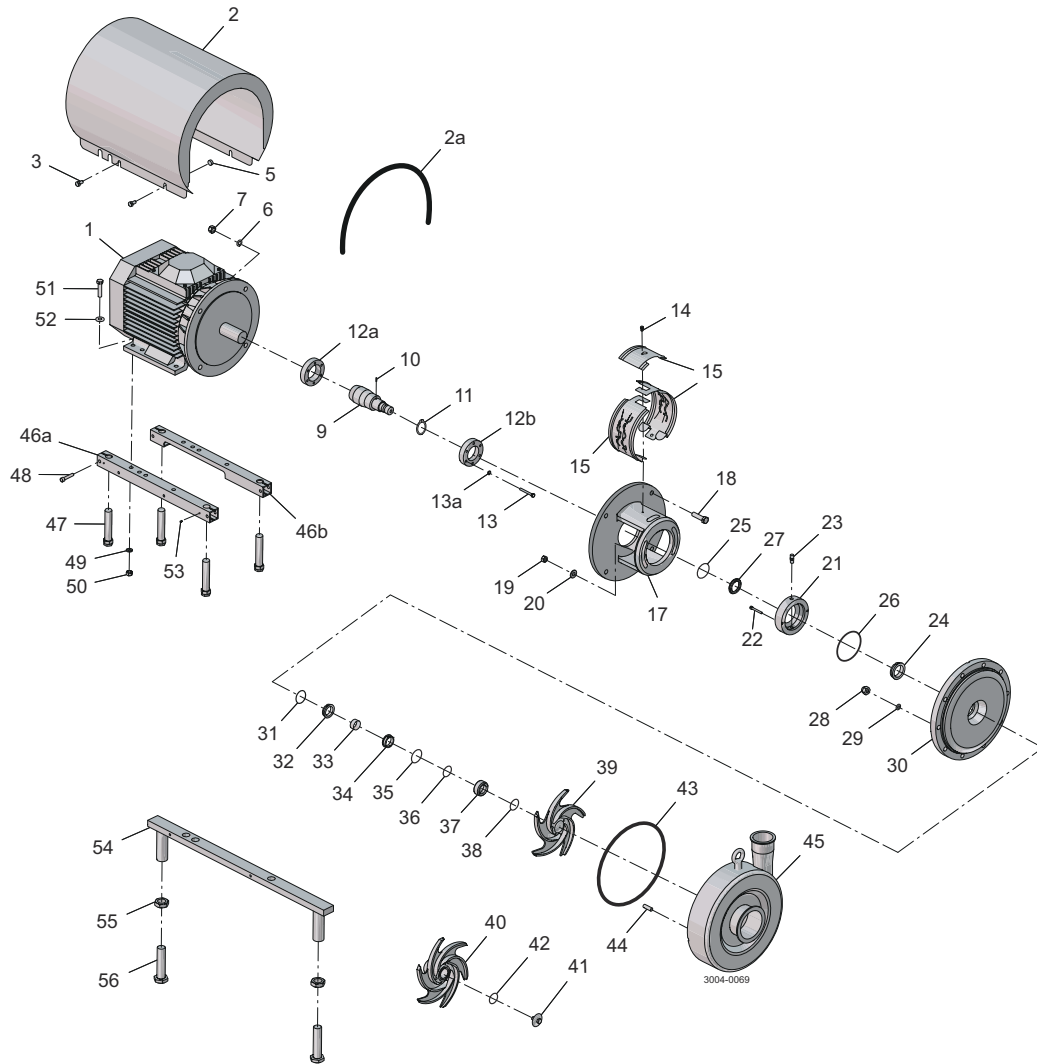

Pos.	Qty.	Denomination
21	1	Seal housing for flushed seal
22	2	Screw
23	2	Fittings
24	1	Lip seal
25	1	O-ring
26	1	O-ring
27	1	Sleeve
31	1	O-ring

Pos.	Qty.	Denomination
32	1	Stationary seal ring
33	1	Spacing ring
34	1	Rotating seal ring
35	1	Quad ring/O-ring
36	1	PTFE support ring
37	1	Rotating seal housing
38	1	Quad ring/O-ring
57	1	Set of 8 springs for rotating seal-housing
	1	Set of 14 springs for rotating sealhousing