

Note that all unique customer requirements (i.e tolerance) need to be verified thru Alfa Laval.

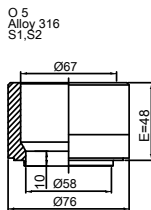
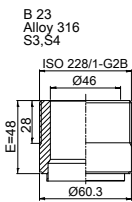
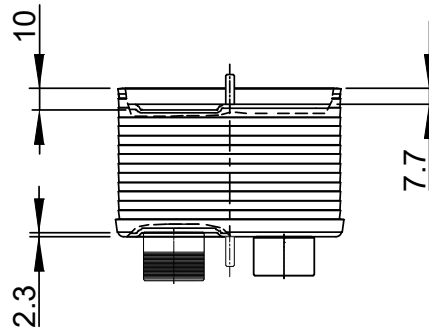
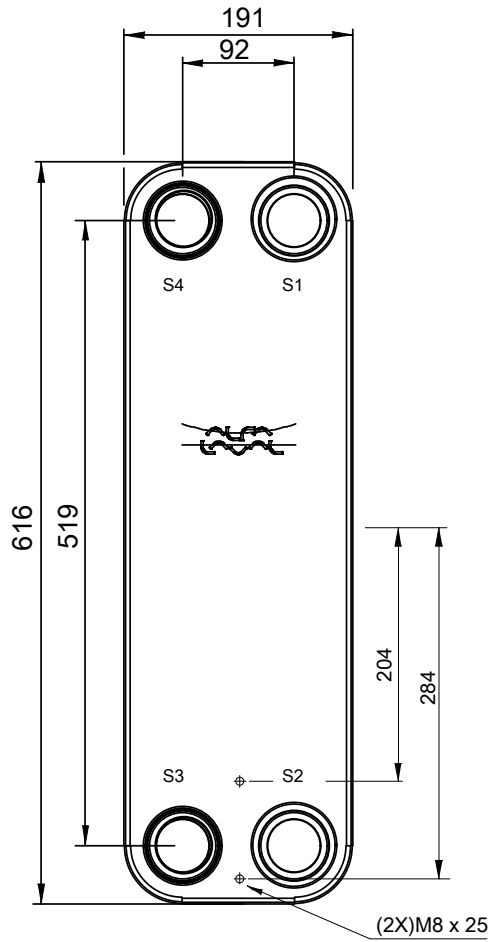
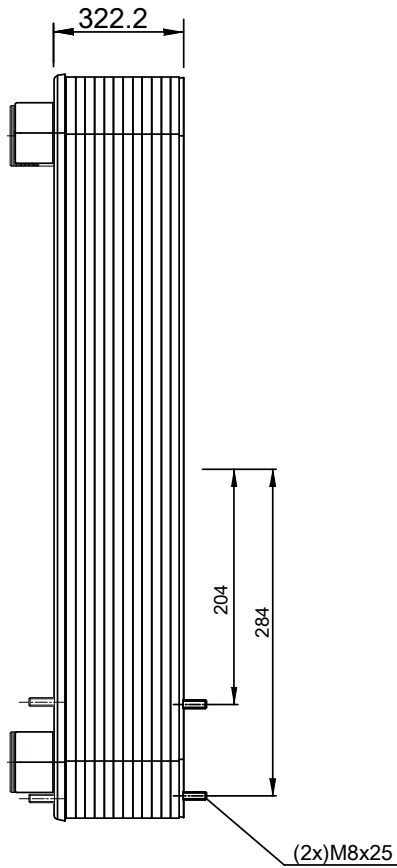

HEATING SURFACE
 NETWEIGHT 52.9 kg
 OPERATING WEIGHT kg
 PLATE MATERIAL ALLOY 316
 PLATE GROUPING 1*59L/1*60L

ALL DIMENSIONS IN MILLIMETERS

SIDE	MEDIA	INLET	TEMP.	OUTLET	TEMP.	FLOW RATE	PRESSURE DROP	LIQUID VOL.
1		S1		S2				12.6 dm ³
2		S3		S4				12.4 dm ³

PRESSURE VESSEL APPROVAL

PED

CB110-120L (3287101761)

www.alfalaval.com

CUSTOMER NAME / REF. NO.

TOTAL LENGTH 385.2 mm
 TOTAL WIDTH 191.0 mm
 TOTAL HEIGHT 616.0 mm

COMPANY / REF.



4/16/2024
 REV 0