

Alfa Laval Unique SSV Two Step

Single seat valves



Lit. Code

200008030-3-EN-GB

Instruction Manual

Published by
Alfa Laval Kolding A/S
Albuen 31
DK-6000 Kolding, Denmark
+45 79 32 22 00

The original instructions are in English

© Alfa Laval AB 2026-04

This document and its contents are subject to copyrights and other intellectual property rights owned by Alfa Laval AB (publ) or any of its affiliates (jointly "Alfa Laval"). No part of this document may be copied, re-produced or transmitted in any form or by any means, or for any purpose, without Alfa Laval's prior express written permission. Information and services provided in this document are made as a benefit and service to the user, and no representations or warranties are made about the accuracy or suitability of this information and these services for any purpose. All rights are reserved.

Contents

1	Declarations of Conformity	5
1.1	EU Declaration of Conformity	5
1.2	UK Declaration of Conformity	6
2	Safety	7
2.1	Safety Signs	8
2.2	Safety Precautions	10
2.3	Warning Signs in Text	15
2.4	Actuator types	16
2.5	Important Information	17
2.6	Requirements of Personnel	18
2.7	Recycling Information	19
3	Introduction	21
4	Installation	23
4.1	Unpacking/delivery	23
4.2	General installation	24
4.3	Welding	26
5	Operation	29
5.1	Description of valve function	29
5.2	Operation	33
5.3	Troubleshooting	35
5.4	Recommended Cleaning	36
5.4.1	Cleaning	37
6	Maintenance	39
6.1	General maintenance	39
6.2	Dismantling the valve	41
6.3	Plug Seal Replacement (Elastomer)	42
6.3.1	Removal of Plug Seal	42
6.3.2	Pre-mounting of plug seal	42
6.3.3	Mounting plug seal by hand	43
6.3.4	Mounting plug seal with Alfa Laval plug seal tool	43
6.4	Plug Seat Ring Replacement (TR2 and TR3)	45
6.5	Valve Assembly	46
6.6	Actuator types	47
6.7	Actuator Bushing Replacement (Non-maintainable Actuator)	48
6.8	Dismantling of (NC) maintainable actuator	52
6.9	Dismantling of change-over (NO) maintainable actuator	54

6.10	Assembly of maintainable actuator.....	56
6.11	Changing pneumatic movement on fully maintainable actuator (NC/NO).....	57
7	Technical Data.....	59
7.1	Technical Data.....	59
7.2	Physical Data.....	59
8	Spare Parts.....	61
8.1	Ordering Spare Parts.....	61
8.2	Alfa Laval Service.....	61
8.3	Warranty - Definition.....	62
9	Parts Lists and Exploded Views.....	63
9.1	Drawings.....	63
9.2	Unique Single Seat Valve - Two Step 38-101.6 mm - shut-off valve.....	64
9.3	Unique Single Seat Valve - Two Step 38-101.6 mm - change -over valve.....	66
9.4	Mounting tool - Unique SSV - Two Step maintainable actuator.....	68

1 Declarations of Conformity

1.1 EU Declaration of Conformity

The designated company

Alfa Laval Kolding A/S, Albuen 31, DK-6000 Kolding, Denmark, +45 79 32 22 00

Company name, address and phone number

Hereby declare that

Valve

Designation

Unique SSV Two Step PN10

Type

1000000-70000000000, AAX000000001-AAX999999999, AAB000000001-AAB999999999, ABJ000000001-ABJ999999999

Serial number

is in conformity with the following directives with amendments:

- Machinery Directive 2006/42/EC
- Pressure Equipment Directive (PED) 2014/68/EU *category 1 and subjected to assessment procedure Module A. May only be used for fluids in Group 2.*

The person authorised to compile the technical file is the signer of this document.

Vice President BU Hygienic Fluid Handling

Head of Product Management

Title

Mikkel Nordkvist

Name

Kolding, Denmark

Place

2025-05-06

Date (YYYY-MM-DD)



Signature

DoC Revison_ 02_052025



1.2 UK Declaration of Conformity

The designated company

Alfa Laval Kolding A/S, Albuen 31, DK-6000 Kolding, Denmark, +45 79 32 22 00

Company name, address and phone number

Hereby declare that

Valve

Designation

Unique SSV Two Step PN10

Type

1000000-70000000000, AAX000000001-AAX999999999, AAB000000001-AAB999999999, ABJ000000001-ABJ999999999

Serial number

is in conformity with the following directives with amendments:

- The Supply of Machinery (Safety) Regulations 2008
- The Pressure Equipment (Safety) Regulations 2016 *category 1 and subjected to assessment procedure Module A. May only be used for fluids in Group 2.*

Signed on behalf of: Alfa Laval Kolding A/S.

Vice President BU Hygienic Fluid Handling

Head of Product Management

Title

Mikkel Nordkvist

Name

Kolding, Denmark

Place

2025-05-06

Date (YYYY-MM-DD)



Signature

DoC Revison_ 03_052025



2 Safety

Read this first



This Instruction Manual is designed for operators and service engineers working with the supplied Alfa Laval product.

Operators must read and understand the **Safety, Installation and Operating** instructions of the supplied Alfa Laval product before carrying out any work or before you put the supplied Alfa Laval product into service!

Not following the instructions can result in serious accidents.

This documentation describes the authorized way to use the supplied Alfa Laval product. Alfa Laval will take no responsibility for injury or damage if the equipment is used in any other way.

This Instruction Manual is designed to provide the user with the information to perform tasks safely for all phases in the lifetime of the supplied Alfa Laval product.

The operator shall always read the chapter **Safety** first. Hereafter the operator can skip to the relevant section for the task to be carried out or for the information needed.

Always read the chapter **Technical Data** thoroughly.

This is the complete Instruction Manual for the supplied Alfa Laval product.

NOTE

The illustrations and specifications in this Instruction Manual were effective at the date of printing. However, as continuous improvements are our policy, we reserve the right to alter or modify the Instruction Manual without prior notice or any obligation.









The English version of the Instruction Manual is the original manual. Alfa Laval cannot be held responsible for incorrect translations. In case of doubt, the English version applies.

2.1 Safety Signs

Mandatory Action Signs

	General mandatory action sign.
	Refer to instruction manual.
	Use eye protection - safety glasses.
	Use protective hand wear - safety gloves.
	Wear protective equipment - safety helmet.
	Use ear protection in noisy environments - noise protector.
	Wear protective equipment - safety shoes.

Warning Signs

	General warning.
	Transportation with forklift truck or other industrial vehicles if heavy.
	Hot surface and Burn Hazard.
	Cutting danger.
	Corrosive substance.
	Crushing of hands.
	Danger of injury (lasermarked on the actuator). Do not attempt to disassemble the actuator due to spring under load danger! (The lock wire opening is blocked).
	Danger of injury (lasermarked on the actuator). Do not attempt to cut open actuator due to spring under load danger! (The lock wire opening is blocked).
	Danger of injury (label marked on actuator). Do not attempt to cut the actuator open due to spring under load (the lock wire opening is locked).





2.2 Safety Precautions

All warnings in the Instruction Manual are summarised on these pages. Pay special attention to the instructions below so that severe personal injury and/or damage to the supplied Alfa Laval product is avoided.



General

	<p>To prevent unexpected start and contact with electrical live and moving parts.</p> <p>Always disconnect the power supply and air supply safely:</p> <ul style="list-style-type: none"> • The power supply disconnecting device and air supply must be disconnected (in off position) and locked.
---	---





Transportation and Lifting

  	<p>Never lift or elevate in any way other than described in this manual.</p> <p>Always use the original packaging or similar during transportation.</p> <p>Always ensure that personnel must have experience with lifting operations.</p> <p>Always ensure that all connections are disconnected before attempting to remove the valve from the installation.</p> <p>Always ensure that no leakage of lubricants can occur.</p> <p>Always drain liquid out of the valves before transportation.</p> <p>Always ensure sufficient fixing of the valve during transportation - if specially designed packaging material is available, it must be used.</p> <p>Always ensure that compressed air is released.</p>
 	<p>Always use designated lifting points if defined. Ensure that the lifting equipment is suitable for the supplied Alfa Laval product.</p> <p>Always ensure that the unit is securely fixed during transportation.</p> <p>Always ensure the lifting point to be in line with center of gravity. Adjust lifting point if necessary.</p> <p>Always use suitable transport device ie. forklift or pallet lifter.</p> <p>Always use appropriate lifting equipment for heavy parts when relevant. Use lifting logs when available.</p> <p>Always keep an eye on the load and stay clear during the lifting operation.</p>







Installation

	<p>If the local safety regulations prescribe that the installation has to be inspected and approved by responsible authorities before the valve is put into service, consult with such authorities before installing the equipment and have the projected installation approved by them.</p> <p>Always release compressed air after use.</p> <p>Always assemble the valve completely before startup and make sure everything is in place and correctly tightened.</p>
	<p>Never work on the valve or touch moving parts if the actuator is supplied with compressed air.</p> <p>Always ensure that the valve and pipelines are depressurized, emptied, and cooled down to ambient temperature before installation, inspection, assembly, or dismantling of the valve.</p> <p>Never touch the valve or the pipelines when processing hot liquids or when sterilising.</p>
	<p>Do NOT attempt to disassemble or by other means open the actuator due to spring under load danger!</p>

Operation

	<p>Never operate the valve unless a correct installation has been verified.</p> <p>Never dismantle the valve during operation or when pressurized.</p>
	<p>Never touch the valve or pipelines when hot.</p> <p>Never touch the valve or the pipelines when processing hot liquids or when sterilising.</p>
	<p>Always rinse well with clean water after cleaning.</p> <p>Always handle lye and acid with great care.</p> <p>Always follow the instructions in the safety data sheets from the suppliers of cleaning agents, detergents, oils etc.</p>
	<p>Never touch moving parts of the valve during operation.</p> <p>Always release compressed air after use.</p>

Maintenance

	<p>In order to optimise the operation of the supplied Alfa Laval product and to minimize the down time due repair activities, the maintenance includes:</p> <ul style="list-style-type: none"> • Inspection and maintenance of the supplied Alfa Laval product: strictly follow the technical documentation • Preventive maintenance: visual inspection of the supplied Alfa Laval product followed by necessary adjustments and planned periodic replacement of wear and tear parts • Repairs: unscheduled break down of a component, often causing the system to stop. Damaged components must be replaced • Stock of Alfa Laval genuine spare parts: Alfa Laval recommend keeping a stock of genuine spare parts facilitating preventive maintenance and reducing downtime in case of unplanned break downs
 	<p>Always release compressed air after use.</p> <p>Always ensure that the valve and pipelines are depressurized, emptied, and cooled down to ambient temperature before dismantling the valve.</p> <p>Never stick your fingers through the valve ports if the actuator is supplied with compressed air.</p> <p>Never work on the valve or touch moving parts if the actuator is supplied with compressed air.</p>
  	<p>Do NOT attempt to disassemble or by other means open the actuator due to spring under load danger!</p> <p>Never pressurize the valve/actuator when the valve is serviced unless specifically prescribed.</p>





Storage

	<p>Alfa Laval recommend:</p> <ul style="list-style-type: none"> • Store the supplied Alfa Laval product as supplied in original packaging • Port opening(s) should be protected against any ingress • Store in a clean, dry place without direct sunlight or UV light • Temperature range -5 °C to +40 °C (23 °F - 104 °F) • Relative humidity less than 60% • No exposure to corrosive substances (including contained air)
---	---

Noise

	<p>Under certain operating conditions, the supplied Alfa Laval product and/or the systems in which they are installed can produce high sound pressure levels. Appropriate noise protection measures should be taken when necessary and in accordance with local legislation.</p>
---	--

Hazards

	<p>Burn Hazard</p> <ul style="list-style-type: none">• Lubrication oil, machine parts and various machine surfaces can be hot and cause burns. Wear protective gloves
	<p>Corrosive Hazard</p> <ul style="list-style-type: none">• Always handle cleaning liquids, lye and acid with great care and in accordance with separate instructions for those fluids• When using chemical cleaning agents and lubricants, make sure you follow the general rules and suppliers recommendation regarding ventilation, personnel protection etc.
	<p>Cut Hazard</p> <ul style="list-style-type: none">• Sharp edges, especially on bowl discs and threads, can cause cuts. Wear protective gloves
	<p>Crushing Hazard</p> <ul style="list-style-type: none">• Avoid placing hands into valve orifice pinch points

Safety check



A visual inspection of any protective device (shield, guard, cover or other) on the supplied Alfa Laval product shall be carried out at least every 12 months. If the protective device is lost or damaged, especially when this leads to deterioration of safety performance, it shall be replaced. The fixing of the protective device should only be replaced with fixings of the same or an equivalent type.

Inspection acceptance criteria:

- It should not be possible to reach moving parts originally protected by a protective device
- The protective device must be securely mounted
- Ensure that screws for the protective device are securely tightened

Procedure in case of non-acceptance:

- Fix and/or replace the protective device

2.3 Warning Signs in Text

Pay attention to the safety instructions in this Instruction Manual.

Below are definitions of the four grades of warning signs used in the text where there is a risk for injury to personnel or damage to the supplied Alfa Laval product.



Indicates an imminently hazardous situation which, if not avoided, will result in death or serious injury.



Indicates a potentially hazardous situation which, if not avoided, could result in death or serious injury.



Indicates a potentially hazardous situation which, if not avoided, may result in minor or moderate damage to the supplied Alfa Laval product.



Indicates important information to simplify or clarify procedures.



2.4 Actuator types

Different actuator types for the SSV valve

In June 2016 the below change was implemented and the “removable yoke with bolts” version is thereby phased out and replaced by the “yoke without bolts” version.

! NOTE

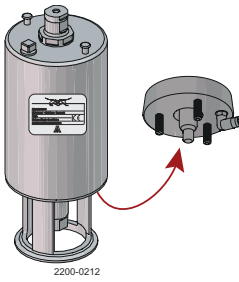
It is important to check for warnings marked on the actuator when servicing an actuator - see below table.

	Fully maintainable actuator	Fully maintainable actuator
Actuator type	Spring cage and can be opened 	Spring cage and can be opened 
Yoke type	“Removable yoke with bolts”. If the yoke with bolts is damaged it has to be replaced by the “yoke without bolts”.	“Yoke without bolts”
Service	Yes	Yes
Marked with warnings	No	No
Year of production	From 2006 to June 2016	From June 2016

2.5 Important Information

Actuators

If support air is utilised:

CAUTION Shock in the actuator must never occur.

To prevent shock in the actuator and to prevent exceeding 10 bar/145 PSI product pressure, Alfa Laval recommends **not** to exceed 3 bar/43.5 PSI support air on the spring side in all the Unique SSV actuators.

CAUTION Support air on high pressure actuator versions is not allowed.

If support air is connected always use the 3 bar/43.5 PSI air relief fittings = 9611995903/9611996094 (1/4" = 6.35 mm hose). Using the air relief fitting also extends the service life of the actuator piston O-ring.

Obs. if using a 6 mm hose then use air relief fittings = 9611995903.

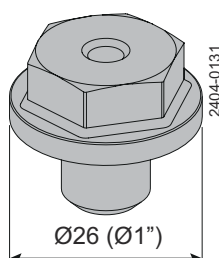

Pos. no. 5

For actuators, manufactured year 2005-2018, with serial number from 1000000 - 5999999 and from 20000000000 - 59999999999 always use steel adapter (pos 5) = 9614065301

Tighten torque = 30 Nm/23 lbf-ft

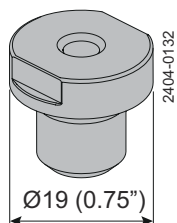

Pos. no. 5

For actuators, manufactured year 2019 --> with serial number from 6000000 to 7000000 and from 60000000000 to 70000000000 always use steel adapter (pos 5) = 9615374701

Tighten torque = 15 Nm/11 lbf-ft

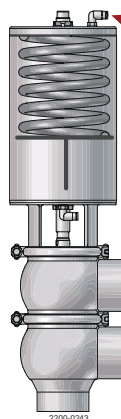

- * Alfa Laval recommends max. 3 bar support air.
- * Always use the "3 bar/43.5 PSI air relief fittings" on support air.
- * Alfa Laval article number = 9611995903/9611996094.
- * (1/4" = 6.35 mm hose).

2.6 Requirements of Personnel

Operators

The operators shall read and understand this Instruction Manual.

Maintenance personnel

The maintenance personnel shall read and understand this Instruction Manual. The maintenance personnel or technicians shall be skilled within the field required to carry out the maintenance work safely.

Trainees

Trainees can perform tasks under the supervision of an experienced employee.

People in general

The public shall not have access to the supplied Alfa Laval product.

In some cases, specially skilled personnel may need to be hired (i.e. electricians, welders). In some cases the personnel has to be certified according to local regulations with experience of similar types of work.

2.7 Recycling Information



If the actuator is marked with one of the below warnings, do **NOT** attempt to disassemble it.

The spring inside is under load — any type of breakage of the actuator can lead to severe injury or even death!



Unpacking

Packing material may consist of wood, plastics, cardboard boxes and in some cases metal straps.



- Wood and cardboard boxes can be reused, recycled or used for energy recovery
- Plastics should be recycled or burnt at a licensed waste incineration plant
- Metal straps should be sent for material recycling

Maintenance

During maintenance, oil (if used) and wear parts in the supplied Alfa Laval product should be replaced.

- Oil and all non-metal wear parts must be disposed of in accordance with local regulations
- Rubber and plastics should be burnt at a licensed waste incineration plant. If not available they should be disposed of in accordance with local regulations
- Bearings and other metal parts should be sent to a licensed handler for material recycling
- Seal rings and friction linings should be disposed of to a licensed land fill site. Check your local regulations
- All metal parts should be sent for material recycling
- Worn out or defected electronic parts should be sent to a licensed handler for material recycling

Scrapping

At end of use, the equipment must be recycled in accordance with the relevant local regulations. Besides the equipment itself, any hazardous residues from the process liquid must be considered and dealt with in a proper manner. When in doubt, or in the absence of local regulations, please contact your local Alfa Laval sales company.

How to contact Alfa Laval

Contact details for all countries are continually updated on our website.

Please visit www.alfalaval.com to access the information directly.

3 Introduction

The Alfa Laval Unique SSV Two Step is a versatile, reliable pneumatic single seat valve with a single contact surface between the plug and the seat to minimize the risk of contamination. Its compact, modular and hygienic design meets the highest process demands in terms of hygiene and safety.

Built on the well-proven Alfa Laval Unique SSV platform, it is ideal for dosing and two-stage filling to ensure an exact volume or for draining of two pipes at the same time while reducing the risk of pressure shocks. Adjustable lifting height makes it possible to match specific volumes and quantities.

Few moving parts ensure easy dismantling, high reliability and low maintenance costs. A wide range of optional features enables customization to specific process requirements.

This page is intentionally left blank.

4 Installation

4.1 Unpacking/delivery

NOTE

The instruction manual is part of the delivery. Study the instructions thoroughly.

The items refer to *Parts Lists and Exploded Views* on page 63.

The valve is supplied as separate parts as standard (for welding).

The valve is assembled before delivery, if it is supplied with fittings.

CAUTION

Alfa Laval cannot be held responsible for incorrect unpacking.

Check the delivery for:

1. Complete valve, shut-off valve or change-over valve
2. Delivery note

2a

Shut-off valve:

- Complete actuator
- 19. Clamp
- 20. Bonnet
- 22. Valve body
- 23. Valve plug

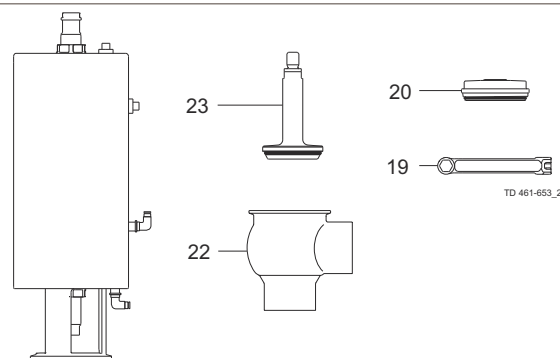

2b

Change-over valve:

- Complete actuator
- 19. 2 x clamps
- 20. Bonnet
- 22. Lower valve body
- 26. Upper valve body
- 27. Valve plug
- 28. Valve seat

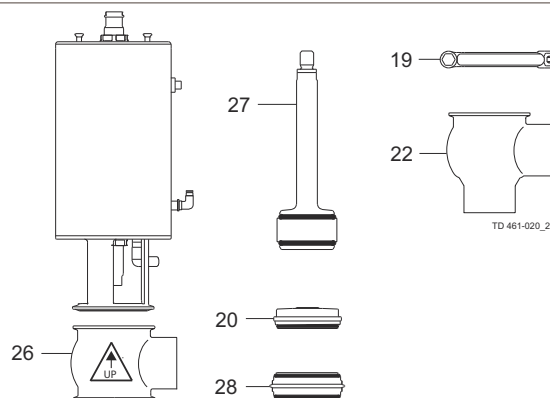

- 1 Remove possible packing materials from the valve/valve parts.
- 2 Inspect the valve/valve parts for visible transport damage.
Avoid damaging the valve/valve parts.

4.2 General installation

NOTE

Study the instructions carefully and pay special attention to the warnings!
 The valve has welding ends as standard but can also be supplied with fittings.
Always read the *Technical Data* on page 59 thoroughly.

NOTE

For EHEDG approved valves, use connection in compliance with the EHEDG position paper "Easy cleanable Pipe couplings and Process connections."
 For EHEDG compliance during cleaning a minimum velocity of 1.5 m/s is required.
 Ensure self-drainage E.g. by installing vertically or having the side port facing downwards.

CAUTION

Alfa Laval cannot be held responsible for incorrect installation.

WARNING

Always release compressed air after use.

WARNING Moving parts!

Never touch the moving parts if the actuator is supplied with compressed air.

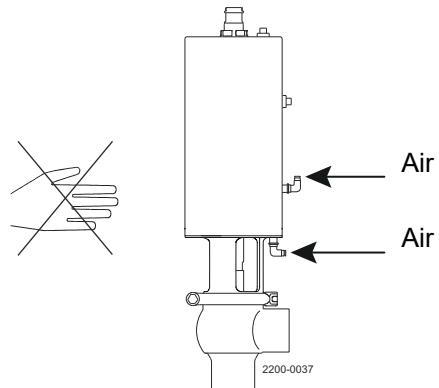

To avoid water hammering, it is recommended to install the valve so that the flow is against the spring closing direction.

Shock in the actuator must **never** occur.

Avoid water hammering!

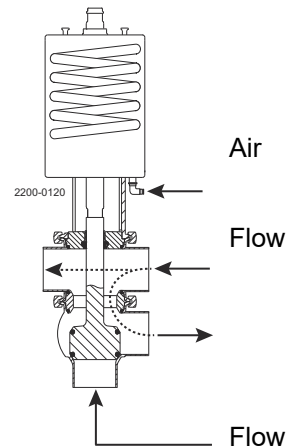

Avoid stressing the valve.

Pay special attention to:

- Vibrations
- Thermal expansion of the pipelines
- Excessive welding
- Overloading of the pipelines

Risk of damage!

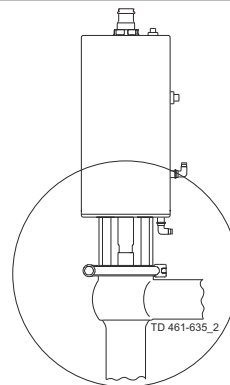

Make sure that the leak detection hole in the valve body:

1. is visible, when mounting the valve vertically
2. is always downwards due to self-draining, when the valve is mounted horizontally

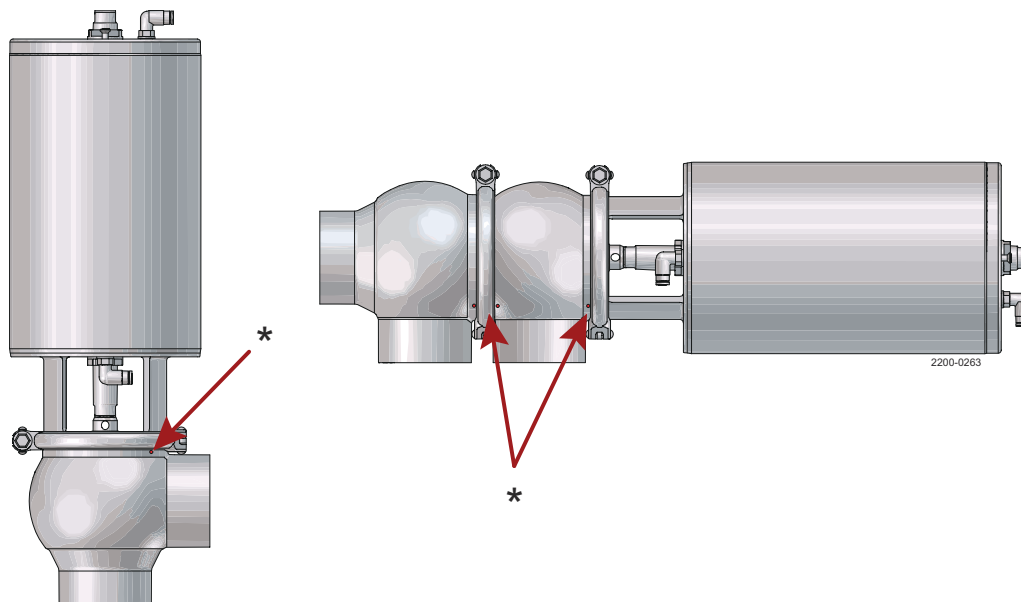

* = Leakage detection hole

4.3 Welding

NOTE

Study the instructions thoroughly.

The valve is supplied as separate parts to facilitate the welding.

The items refer to [Parts Lists and Exploded Views](#) on page 63.

Check the valve for smooth operation after welding.

- 1 **Always** install valves with more than one valve body so that the seals between the valve bodies can be replaced. Do not weld more than one valve body into the system. It is recommended to fit sufficient clamps/unions to be able to disassemble the valve for servicing.

Valve size	A	B
DN40/38 mm (1½")	*	740 mm (29.1")
DN50/51 mm (2")	*	770 mm (30.3")
DN65/63.5 mm (2½")	*	780 mm (30.7")
DN80/76 mm (3")	*	830 mm (32.7")
DN100/101.6 mm (4")	*	880 mm (34.65")

* Depending on body combination and piping solution.

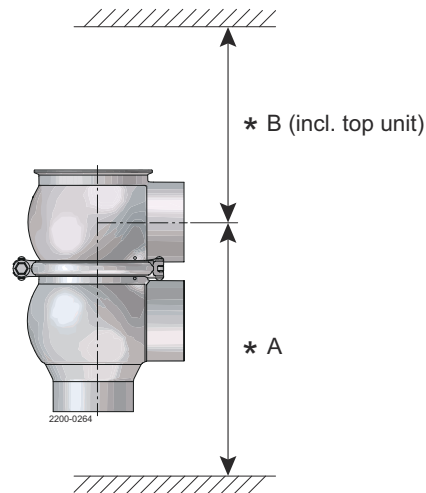

- 2 Assemble the valve in accordance with the steps on page [Valve Assembly](#) on page 46.

Pay special attention to the warnings!

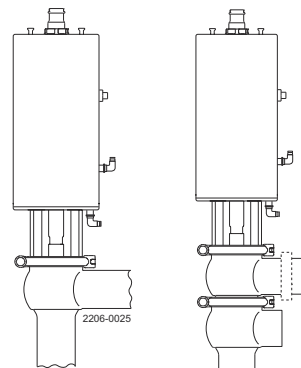

- 3 **Pre-use check:**

1. Supply compressed air to the actuator
2. Open and close the valve several times to ensure that it operates smoothly

Pay special attention to the warnings!

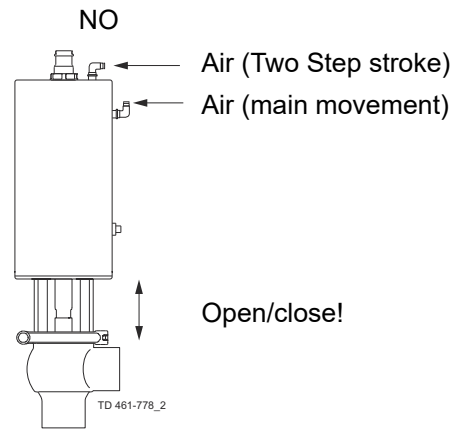
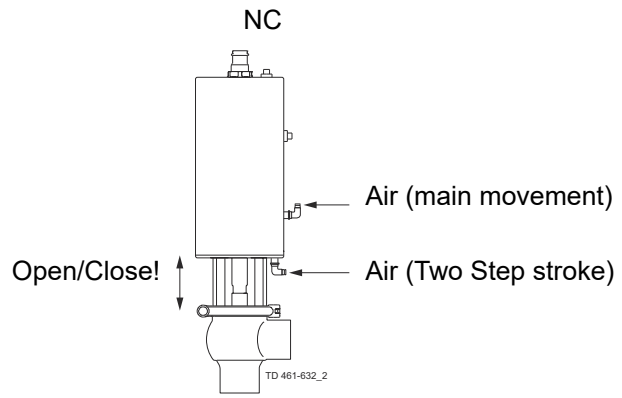

This page is intentionally left blank.

5 Operation

5.1 Description of valve function

NOTE

Study the instructions thoroughly.

The item refer to [Parts Lists and Exploded Views](#) on page 63.

NO = Normally open (pneumatic movement downwards).

NC = Normally closed (pneumatic movement upwards).

The SSV Two step valve has two pistons inside the actuator, which makes it possible to have an intermediate plug position where all body ends are open.

SSV Two step valves are made in a shut-off valve type and a change-over valve type.

Type shut-off valve (only NC)

Two step valves as shut-off (only as NC) can be used for reducing pressure hammers or dosing e.g. in connection with filling of a vessel where an exact volume is required.

The degree of opening for the intermediate position can be adjusted by removing spacer rings inside the actuator (see [Dismantling of \(NC\) maintainable actuator](#) on page 52).

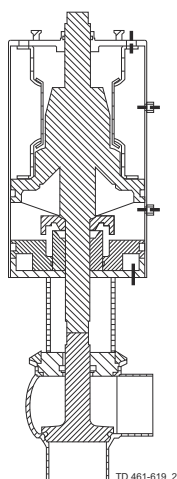

Closed

Throttled position can be adjusted by removing spacers. Plug opening will increase if spacers are removed

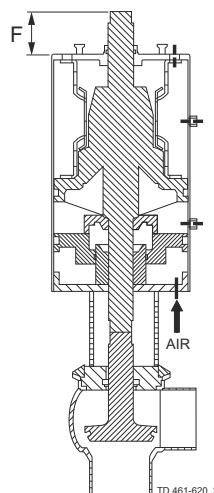

Throttled opening

Two step stroke activated

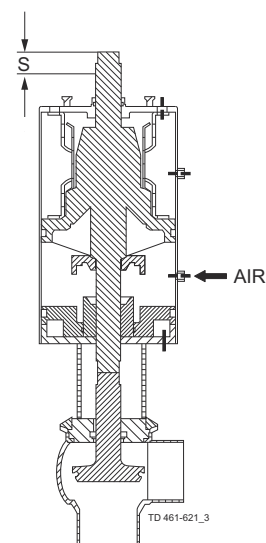

Full open

The plug opening for different shut-off valves and actuator size is shown below.

Dimensions = mm (inch)	Standard actuator choice (NC)									
	Inch tube					DIN tube				
	38 (1½")	51 (2")	63.5 (2½")	76.1 (3")	101.6 (4")	40 (1½")	50 (2")	65 (2½")	80 (3")	100 (4")
F min. Two step stroke (with spacers inside actuator)	3 (0.12)	3 (0.12)	3 (0.12)	2.5 (0.10)	2.5 (0.10)	3 (0.12)	3 (0.12)	3 (0.12)	2.5 (0.10)	2.5 (0.10)
F max. Two step stroke (spacers removed inside actuator)	6 (0.24)	11 (0.43)	11 (0.43)	14 (0.55)	14 (0.55)	6 (0.24)	11 (0.43)	11 (0.43)	14 (0.55)	14 (0.55)
S = full stroke opening	20 (0.79)	25 (1.00)	25 (1.00)	30 (1.18)	30 (1.18)	20 (0.79)	25 (1.00)	25 (1.00)	30 (1.18)	30 (1.18)

Dimensions = mm (inch)	High pressure actuator (NC)			
	Inch tube		DIN tube	
	51 (2")	63.5 (2½")	50 (2")	65 (2½")
F min. Two step stroke (with spacers inside actuator)	6 (0.24)	6 (0.24)	6 (0.24)	6 (0.24)
F max. Two step stroke (spacers removed inside actuator)	9 (0.35)	9 (0.35)	9 (0.35)	9 (0.35)
S = full stroke opening	25 (1.00)	25 (1.00)	25 (1.00)	25 (1.00)

Type change-over valve (NC and NO)

Two step valves as change-over (NC and NO) can be used for drainage of two pipes simultaneously or split of flow in three lines. The valve has a fixed intermediate position and spring return to the end positions.

Spring return to lower position = NC

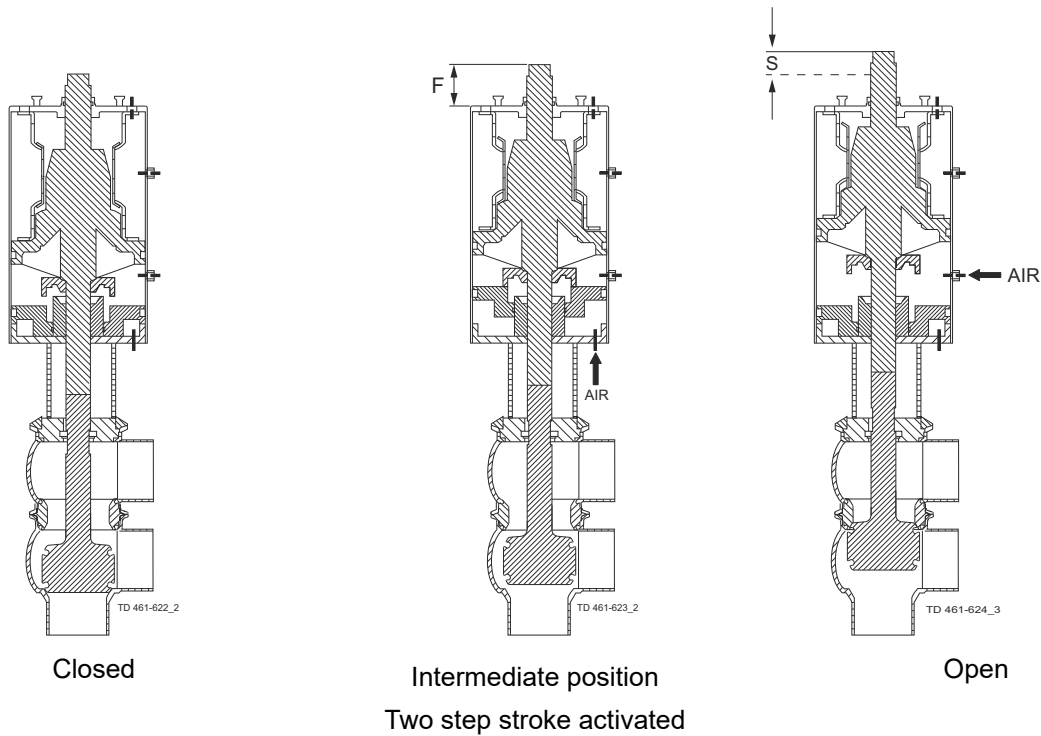

The plug opening for different change-over valves and actuator size is shown below.

Dimensions = mm (inch)	Standard actuator choice (NC)									
	Inch tube					DIN tube				
	38 (1½")	51 (2")	63.5 (2½")	76.1 (3")	101.6 (4")	40 (1½")	50 (2")	65 (2½")	80 (3")	100 (4")
F = fixed intermediate position	6.5 (0.56)	11 (0.43)	11 (0.43)	14 (0.55)	14 (0.55)	6.5 (0.56)	11 (0.43)	11 (0.43)	14 (0.55)	14 (0.55)
S = full stroke opening	17 (0.67)	22 (0.87)	22 (0.87)	27 (1.07)	27 (1.07)	17 (0.67)	22 (0.87)	22 (0.87)	27 (1.07)	27 (1.07)

Dimensions = mm (inch)	High pressure actuator (NC)			
	Inch tube		DIN tube	
	51 (2")	63.5 (2½")	50 (2")	65 (2½")
F = fixed intermediate position	9 (0.35)	9 (0.35)	9 (0.35)	9 (0.35)
S = full stroke opening	22 (0.87)	22 (0.87)	22 (0.87)	22 (0.87)

Spring return to upper position = NO

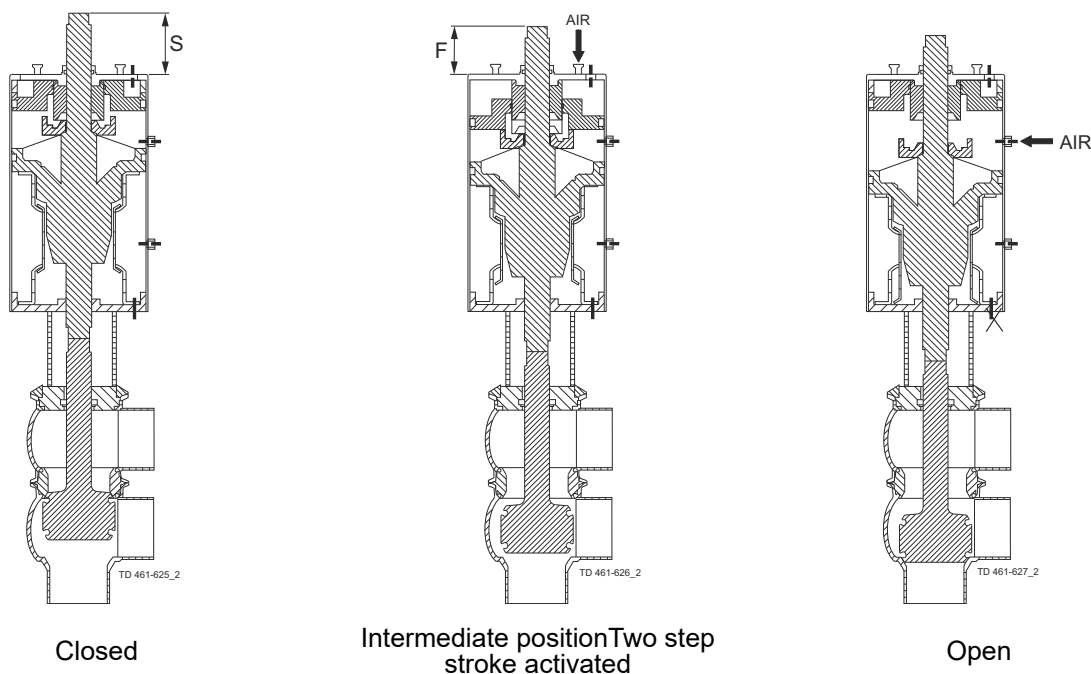

The plug opening for different change-over valves and actuator size is shown below.

Dimensions = mm (inch)	Standard actuator choice (NC)									
	Inch tube					DIN tube				
	38 (1½")	51 (2")	63.5 (2½")	76.1 (3")	101.6 (4")	40 (1½")	50 (2")	65 (2½")	80 (3")	100 (4")
F = Fixed intermediate position	11 (0.43)	11 (0.43)	11 (0.43)	11 (0.43)	11 (0.43)	11 (0.43)	11 (0.43)	11 (0.43)	11 (0.43)	11 (0.43)
S = full stroke opening	17 (0.67)	22 (0.87)	22 (0.87)	27 (1.06)	27 (1.06)	17 (0.67)	22 (0.87)	22 (0.87)	27 (1.06)	27 (1.06)

Dimensions = mm (inch)	High pressure actuator (NC)			
	Inch tube		DIN tube	
	51 (2")	63.5 (2½")	50 (2")	65 (2½")
F = Fixed intermediate position	11 (0.43)	11 (0.43)	11 (0.43)	11 (0.43)
S = full stroke opening	22 (0.87)	22 (0.87)	22 (0.87)	22 (0.87)

5.2 Operation

NOTE

Study the instructions thoroughly and pay special attention to the warnings!

Ensure that the valve operates smoothly.

Always read *Technical Data* on page 59 thoroughly.

The items refer to *Parts Lists and Exploded Views* on page 63.

Always use Alfa Laval genuine spare parts. The warranty of Alfa Laval products is dependent on use of Alfa Laval genuine spare parts.

CAUTION

Alfa Laval cannot be held responsible for incorrect installation.

WARNING

Always release compressed air after use.

WARNING Burn hazard!

Never touch the valve or the pipelines when processing hot liquids or when sterilising.

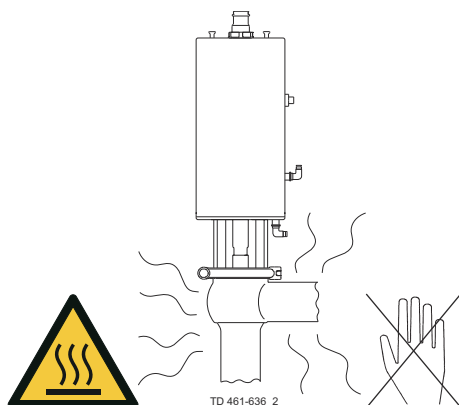

WARNING Moving parts!

Never touch moving parts if the actuator is supplied with compressed air.

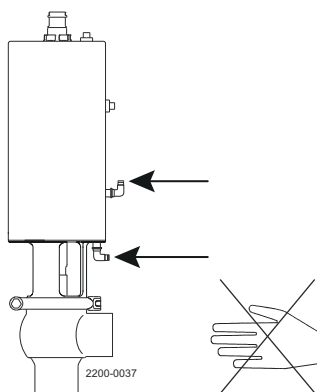

1 Lubrication of valves:

- a) Ensure smooth movement between lip seal (A) and plug stem (B)
- b) Lubricate the lip seal with Alfa Laval Lubricant if necessary (see [General maintenance](#) on page 39)

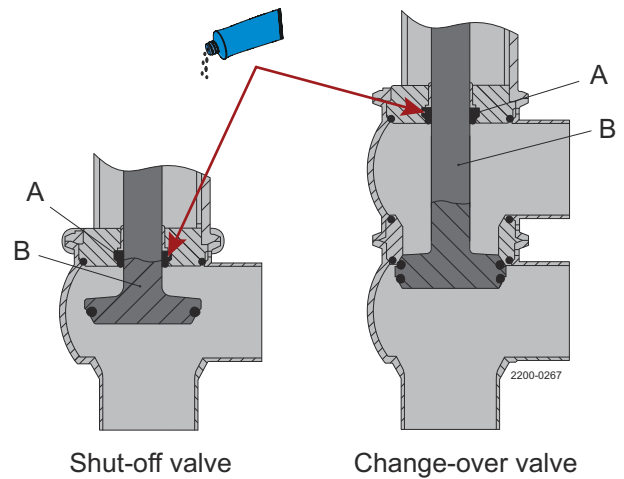
**2 Lubrication of actuator:**

- a) Ensure smooth movement of the actuator (the actuator is lubricated before delivery)
- b) Lubricate all seals with Molykote Longterm 2 plus if necessary

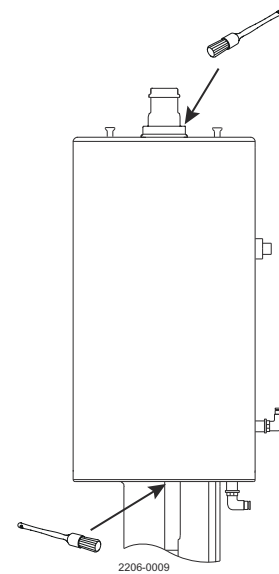

5.3 Troubleshooting

! NOTE

Pay attention to possible faults.

Study the instructions thoroughly.

The items refer to *Parts Lists and Exploded Views* on page 63.

! NOTE

Study the maintenance instructions thoroughly before replacing worn parts - see

General maintenance on page 39!

Problem	Cause/result	Repair
External product leakage	Worn or product affected lipseal and/or O-ring	<ul style="list-style-type: none"> • Replace the seals • Replace with seals of a different rubber grade
Internal product leakage	<ul style="list-style-type: none"> • Worn or product affected plug seal • Product deposits on the seat and/or plug • Product pressure exceeds actuator specification 	<ul style="list-style-type: none"> • Replace the seal • Replace with a seal of a different rubber grade • Frequent cleaning • Replace with a high pressure actuator • Use auxiliary air on the spring side (do not exceed 3 bar/43.5 PSI). Alfa Laval article number = 9611995903. See <i>Safety Precautions</i> on page 10 and <i>General installation</i> on page 24 • Reduce product pressure
Water hammering	The flow direction is the same as the closing direction	<ul style="list-style-type: none"> • The flow direction should be against the closing direction. See <i>General installation</i> on page 24 • Throttle air release of solenoid in top unit
The valve does not open/close	Product pressure exceeds actuator specification	<ul style="list-style-type: none"> • Replace with a high pressure actuator • Reduce product pressure • Use auxiliary air on the spring side. Always use the pressure relief fittings (3 bar/43.5 PSI) on support side. Alfa Laval article number = 9611995903

If marked with a danger warning, do **NOT** attempt to cut the actuator open, due to spring under load.

5.4 Recommended Cleaning

NOTE

The supplied product is designed for cleaning in place (CIP).

NaOH = Caustic soda.

HNO₃ = Nitric acid.

The cleaning agents must be stored/disposed of in accordance with current regulations/directives.

CAUTION

Never touch the supplied product or the pipelines when sterilizing.

Always handle lye and acid with great care.



Examples of cleaning agents

Use clean water free from chlorides

Metric System

1. 1% by weight NaOH at 70°C

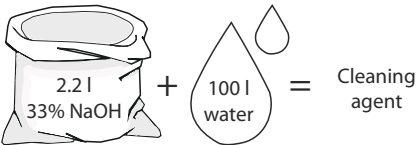
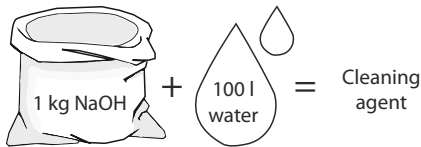

2. 0.5% by weight HNO₃ at 70°C

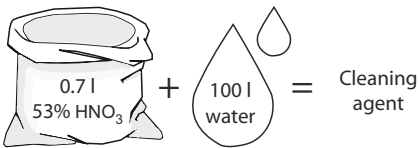

Imperial System

1. 1% by weight NaOH at 158°F

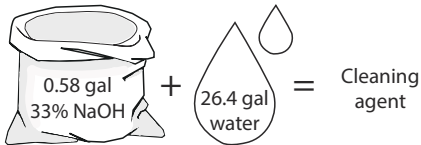
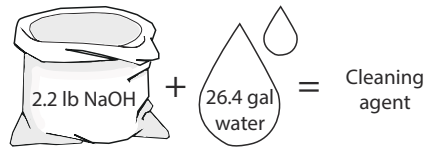

2. 0.5% by weight HNO₃ at 158°F

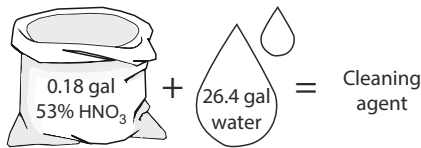

1. Avoid excessive concentration of the cleaning agent ⇒ **Dose gradually!**
2. Adjust the cleaning flow to the process
Milk sterilization/viscous liquids ⇒ Increase the cleaning flow!

CAUTION

Always rinse well with clean water after the cleaning.

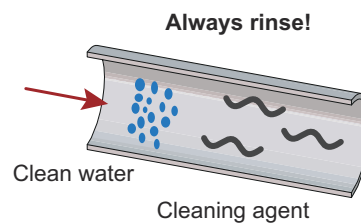

5.4.1 Cleaning

 **WARNING** Danger of burns!

Danger of burns!

Never touch the valve or the pipelines when sterilizing.



 **NOTE**

Pay special attention to the warnings!

Clean the plug and seats correctly.

Lift and lower valve plug momentarily!

This page is intentionally left blank.

6 Maintenance

6.1 General maintenance

NOTE

Maintain the valve regularly.

Study the instructions thoroughly and pay special attention to the warnings!

Always keep spare rubber seals and lip seals in stock.

Check the valve for smooth operation after service.

Always read *Technical Data* on page 59 thoroughly.

Always use Alfa Laval genuine spare parts. The warranty of Alfa Laval products is dependent on use of Alfa Laval genuine spare parts.

CAUTION

Alfa Laval cannot be held responsible for incorrect installation.

WARNING

Always release compressed air after use.

WARNING

Burn hazard!

Never service the valve when it is hot.

Never service the valve when the valve or pipelines are under pressure.

Atmospheric pressure required!

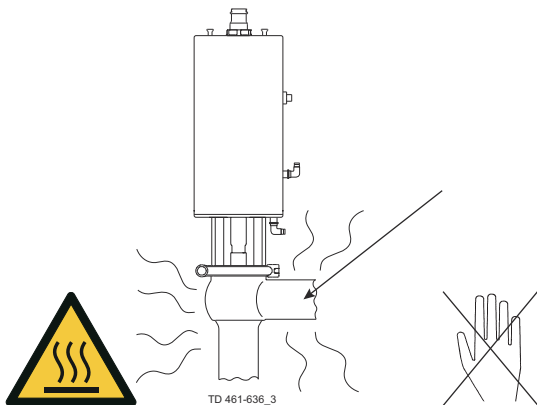

WARNING Cutting hazard!

Moving parts!

Never stick your fingers through the valve ports if the actuator is supplied with compressed air.

Never touch the moving parts if the actuator is supplied with compressed air.

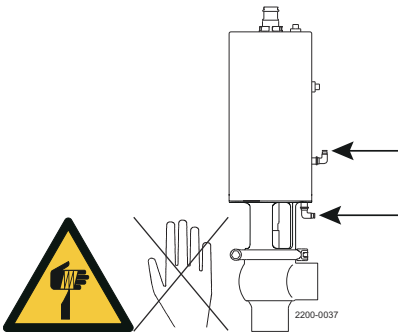

Below are some guidelines for maintenance and lubrication intervals. Please note that the guidelines are for normal working conditions in one shift.

	Product wetted seals	Actuator bushings complete
Preventive maintenance	Replace after 12 months depending on working conditions	Replace after 5 years depending on working conditions
Maintenance after leakage (leakage normally starts slowly)	Replace at the end of the day	Replace when possible
Planned maintenance	<ul style="list-style-type: none"> Regular inspection for leakage and smooth operation Keep a record of the valve Use the statistics for inspection planning Replace after leakage	<ul style="list-style-type: none"> Regular inspection for leakage and smooth operation Keep a record of the actuator Use the statistics for inspection planning Replace after leakage
Lubrication	Before fitting Alfa Laval Silicon based Food-grade Lubricant USDA H1 approved grease	Before fitting Molykote Longterm 2 plus

Pre-use check:

1. Supply compressed air to the actuator
2. Open and close the valve several times to ensure that it operates smoothly

Pay special attention to the warnings!

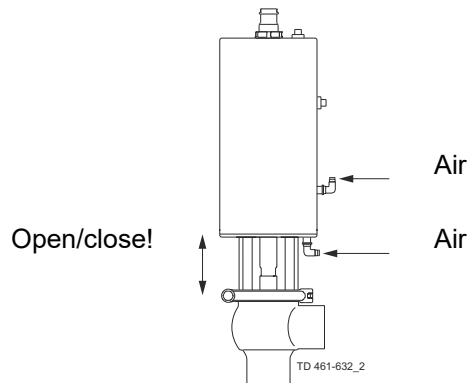

Recommended spare parts

See [Parts Lists and Exploded Views](#) on page 63.

6.2 Dismantling the valve

NOTE

Study the instructions thoroughly.

The items refer to [Parts Lists and Exploded Views](#) on page 63.

Handle scrap correctly.

NC = Normally closed.

NO = Normally open.

Shut-off valve:

1. Supply compressed air to the actuator (only NC)
2. Loosen and remove clamp
3. Release compressed air (only NC)
4. Lift away the actuator
5. Unscrew and remove valve plug
6. Remove O-ring, lip seal and bushing in bonnet.
(Use bushing tool and rubber mallet)

Pay special attention to the warnings!

NOTE For plug seal replacement please see [Plug Seat Ring Replacement \(TR2 and TR3\)](#) on page 45.

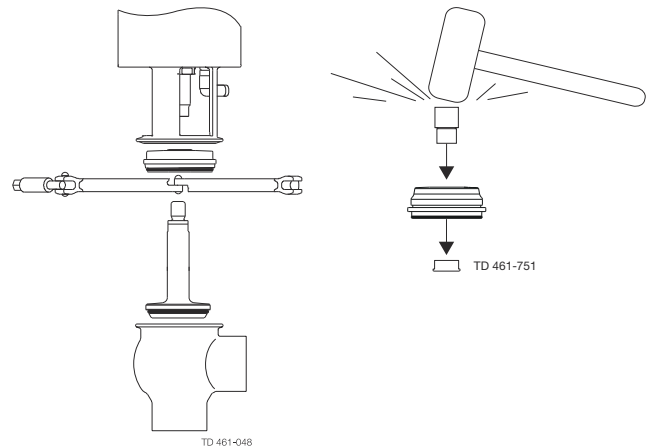

Change-over valve:

1. Supply compressed air to the actuator (only NC)
2. Loosen and remove lower clamp
3. Release compressed air (only NC)
4. Lift away the actuator and upper valve body
5. Supply compressed air to the actuator (only NO)
6. Unscrew and remove valve plug
7. Release compressed air (only NO)
8. Remove seat and O-rings
9. Loosen and remove upper clamp
10. Remove upper valve body
11. Remove O-ring, lip seal and bushing in bonnet.
(Use bushing tool and rubber mallet. See drawing above)

Pay special attention to the warnings!

NOTE For plug seal replacement please see [Plug Seat Ring Replacement \(TR2 and TR3\)](#) on page 45.

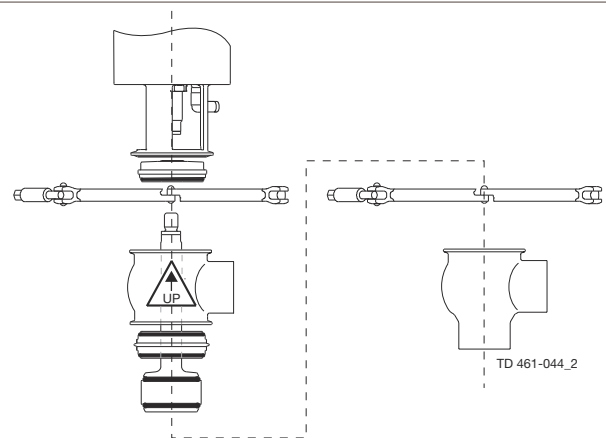

6.3 Plug Seal Replacement (Elastomer)

6.3.1 Removal of Plug Seal

Remove old seal ring using a knife, screwdriver or similar. Be careful not to damage the plug surface.

NOTE

Be careful not to scratch the plug surface.

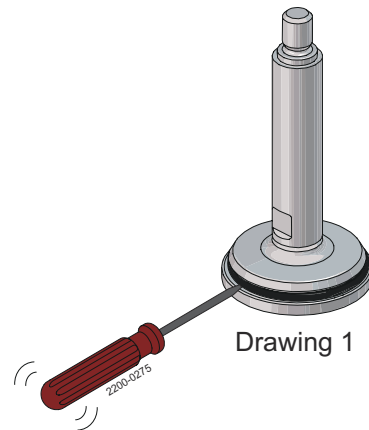

6.3.2 Pre-mounting of plug seal

- 1 Lubricate the new plug seal with Alfa Laval Silicone based Food-grade Lubricant, which is included in the service kit.

Only a small amount is needed.

- 2 Fit the plug seal onto the plug seal groove.

NOTE

Be careful not to twist the plug seal.

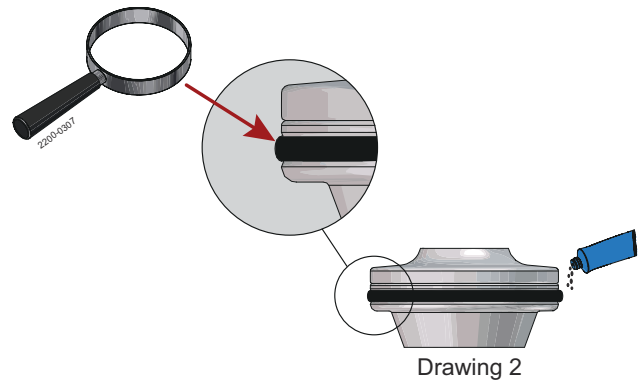

- 3 The plug seal can now be mounted by hand or with the Alfa Laval plug tool.

6.3.3 Mounting plug seal by hand

- 1 Ensure full circumferential seating of the sealing by applying opposite pressure with your fingers. Eg. A - B and C - D.

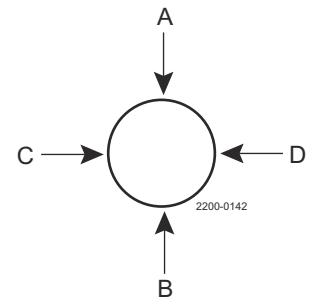

If a bulge is present, apply pressure on the plug seal and keep the pressure while rotating the plug 360°.

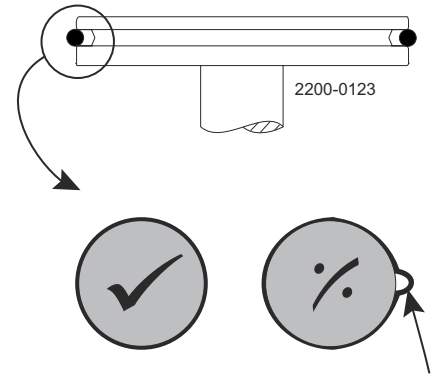

- 2 If necessary, trapped air behind the plug seal can be relieved by use of a small flat-blade screwdriver.

NOTE

Be careful not to scratch the surface of the plug and/or damage the seal.

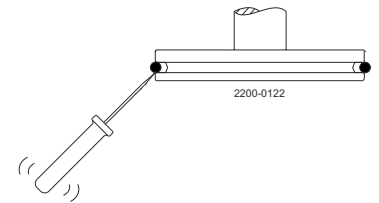

6.3.4 Mounting plug seal with Alfa Laval plug seal tool

Mounting tool for elastomer plug seals	DN40 38 mm	DN50 - DN65 51 mm - 63.5 mm	DN80 - DN100 76.1 mm - 101.6 mm
<p>2200-0277</p>	9613172901	9613172902	9613172903

- A. Part A
- B. Part B
- C. Plugs
- D. O-ring
- E. Alfa Laval Silicone based Food-grade Lubricant from service kit
- F. Flat-blade screwdriver (no sharp corner)
- G. Exhaust holes for screwdriver
- H. Ø20 hole for plug spindle

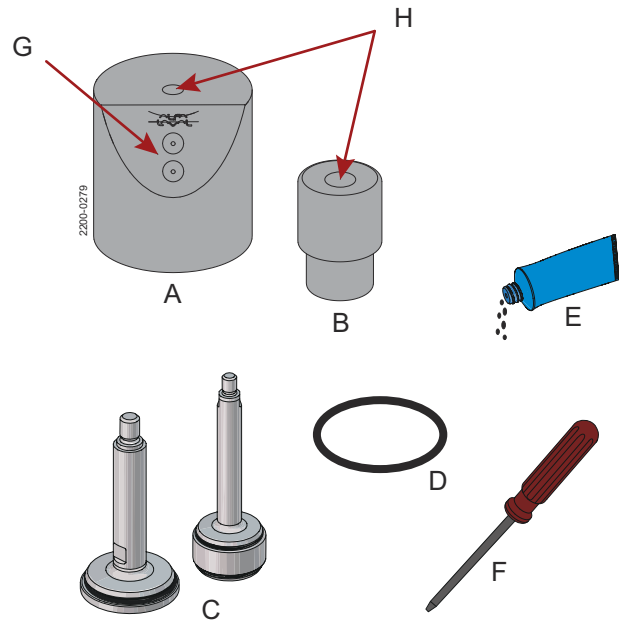

1 Assembly

For shut-off plug - See drawing 1.

For reverse acting plug - See drawing 2.

For change-over plug - See drawing 1 + 2.

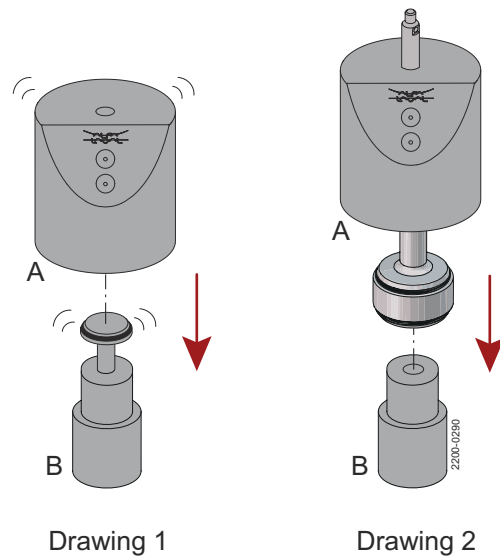

2

- a) Fit the plug according to plug type.
- b) Apply force to push Part A and B together which will ensure full circumferential seating of the sealing.
- c) To relieve trapped air behind the plug sealing, insert the flat-blade screwdriver through the applicable exhaust hole on part A and fit it between the plug sealing and plug.

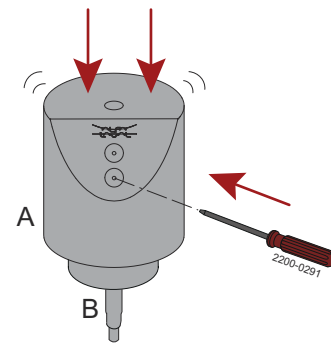

With the flat-blade screwdriver fitted apply force again and a single "hiss" sound can be heard.

NOTE

Be careful not to scratch the surface of the plug and/or damage the seal.

6.4 Plug Seat Ring Replacement (TR2 and TR3)

NOTE

Use the mounting tool for TR2 and TR3- see spare part.

- 1 Place the plug element on a firm support.
- 2 Using a utility knife, partially and *CAREFULLY* cut through the upper ring portion of the TR2 plug avoiding contact with stainless steel stem. For TR3 use a finetoothed hacksaw.
- 3 Force apart both cut ends of the plug for removal from stem.
- 4 For TR2 and TR3 plugs are installed by applying uniform pressure on all sides. (Pressure can be applied by using the seat assembly tool).

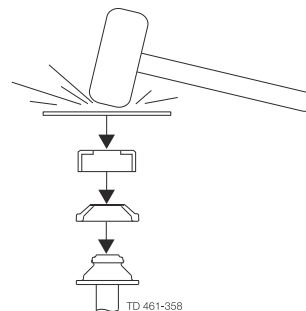

5 Using a piece of metal and a rubber mallet, place a precise tab to make the TR2 plug snap on to the stem.

Reverse the tool and tab again to secure proper fit.

6 Examine seat assembly to be sure the TR2 and TR3 plug is properly mounted, holding the seat assembly in one hand - rotate the TR2 and TR3 plug. (For proper CIP cleaning the TR2 and TR3 plug should turn freely on the stem).

6.5 Valve Assembly

Reverse order of *Dismantling the valve* on page 41.

Lubricate O-ring (21) and lip seal (25) with Alfa Laval Lubricant.

Remember to tighten spindle and plug (use two 17 mm spanners).

- Change-over plug tighten torque = **30 Nm (22 lbf - ft)**
- Shut-off plug tighten torque = **20 Nm (15 lbf - ft)**

If there are vibrations in the pipeline, Alfa Laval recommends to use Loctite no. 243.

The clamps' thread must be lubricated before tightening - torque for the clamps is 10-12 Nm (8-9 lbf - ft).



6.6 Actuator types

Different actuator types for the SSV valve

In June 2016 the below change was implemented and the “removable yoke with bolts” version is thereby phased out and replaced by the “yoke without bolts” version.

NOTE

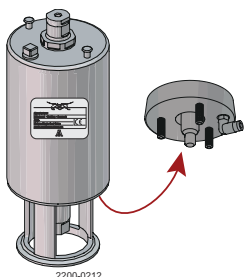
It is important to check for warnings marked on the actuator when servicing an actuator - see below table.

	Fully maintainable actuator	Fully maintainable actuator
Actuator type	Spring cage and can be opened 	Spring cage and can be opened 
Yoke type	“Removable yoke with bolts”. If the yoke with bolts is damaged it has to be replaced by the “yoke without bolts”.	“Yoke without bolts”
Service	Yes	Yes
Marked with warnings	No	No
Year of production	From 2006 to June 2016	From June 2016

6.7 Actuator Bushing Replacement (Non-maintainable Actuator)

Introduction

- The actuator service kit contains two bushings and four O-rings
- Mount the thick O-ring inside and the thin O-ring outside the bushing
- Lubricate the stem and O-rings with "Molykote Longterm 2 Plus" or an equivalent grease before sliding the new bushings onto the actuator stem



Introduction - Standard tubular box wrench

Use a 27 mm (1 1/16") tubular box wrench to unmount and/or mount the bushings.

This tool will allow the actuator stem to fit inside and will provide good access to the bushing placed in the actuator yoke end.

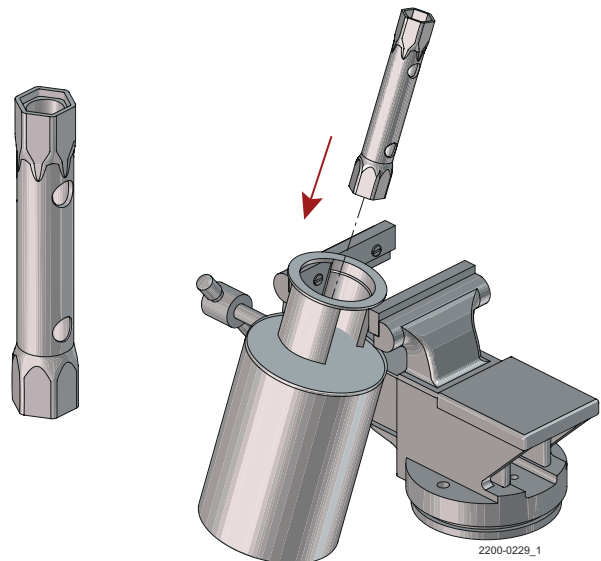

Introduction - Aligning spindle

The actuator spindle can in some cases be forced off centre by the internal spring, as shown.

In cases with misalignment of the actuator stem in relation to the bushing thread, as shown, the tubular box wrench together with a spindle for alignment is a great help and will ensure a reliable mounting of the bushing.

The aligning spindle can either be purchased from Alfa Laval (**9614198401**) which also include a 27 mm (1 1/16") tubular box wrench or it can be manufactured locally using below dimensions.

Dimension A is based on a tubular box wrench with a total length of 185 mm (7 1/4").

Dimensions

A = 280 mm (11")

B = 16 mm (0.63")

C = Rod \varnothing 20 mm (0.79")

D = M12 x 1.5

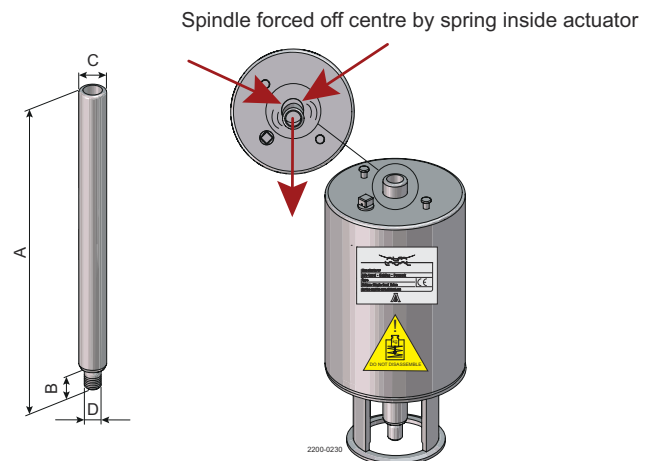

- 1 The actuator must be fixed in a vice, Alfa Laval recommend use of soft jaws.

Be careful not to damage the yoke by over tightening and only fix carefully on the "yoke leg", as shown.

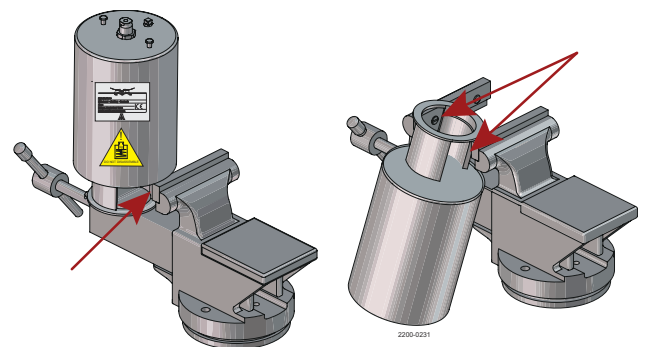

- 2 Remove the adaptor screw.

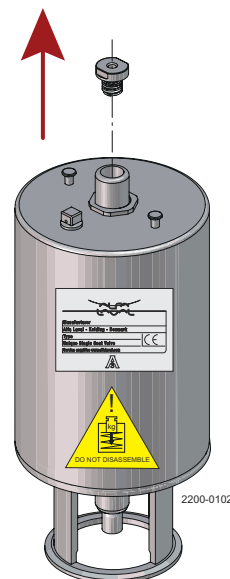

- 3 Slide the lubricated bushing onto the actuator stem.

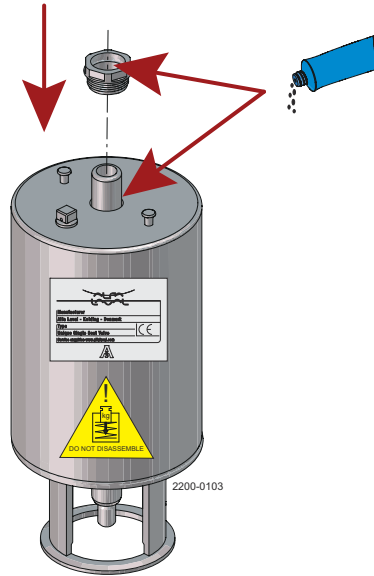

- 4 Fit the aligning spindle to the actuator stem and apply the tubular box wrench.

Aligning spindle

Tubular box wrench

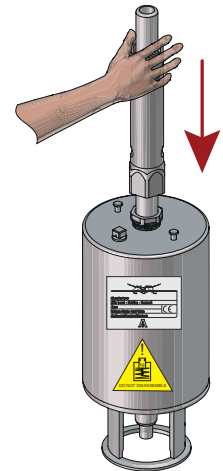
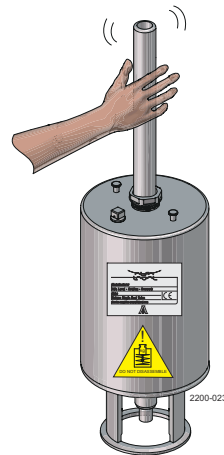

- 5 Now pull the aligning spindle to center the actuator stem in relation to the bushing thread. When centered, initiate fastening of the bushing. Ensure the thread catches evenly!

The bushing must only be tightened with a torque of 10 Nm (7 lb-ft) which is achievable by hand tightening only.

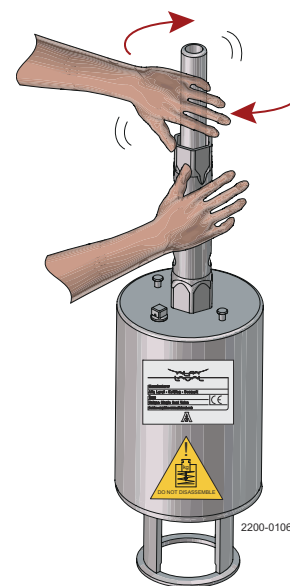

- 6 Mount adaptor screw.

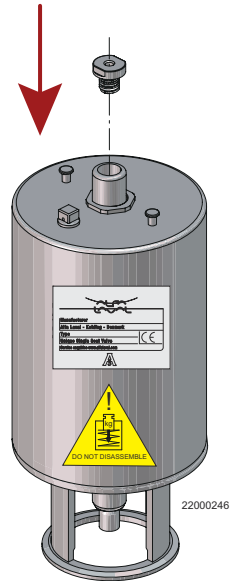

6.8 Dismantling of (NC) maintainable actuator

NOTE

Study the instructions carefully.

The item refer to *Parts Lists and Exploded Views* on page 63.

Changing of wear parts

- 1 Rotate cylinder (1).
- 2 Remove lock wire (10) and pull away cylinder (1).
This can be done by careful using air on fitting (12).
- 3 Remove O-ring (11) from bottom (15).
- 4 Unscrew top bushing (6) and remove o-ring (8).
- 5 Remove piston (2) together with support disk (16), thrust plate (53) and O-ring (3).
- 6 Remove spring assembly (14).
- 7 Remove seegering lock ring (57) using a seegering-tang tool.
- 8 Remove piston (52) and O-rings (3+60) together with spacer rings (56).
Spacer rings (56) are only mounted on shut-off valve and not on change-over valve.
Spacer rings are used to reduce the piston (52) stroke, so that the shut-off valves intermediate plug position can be adjusted.
- 9 Remove guide ring (58) and O-ring (7).

- 10 Guide (54) is screwed on bottom part (15) and should only be dismantled if guide (54) is broken.

If guide (54) has to be dismantled start with unscrewing nuts (18) and remove yoke (13) and loosen nut (55). With a special tool it now is possible to dismantle guide (54). This is shown in *Changing pneumatic movement on fully maintainable actuator (NC/NO)* on page 57 step 2.

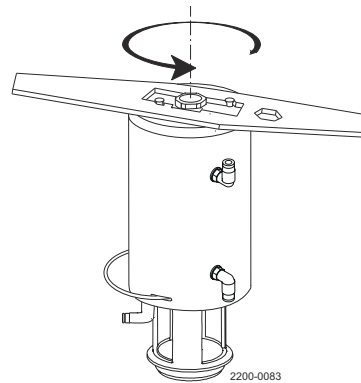

Rotate cylinder with service tool!

56) Only for shut off valves (not mounted in actuator for change-over valves)

59) No wear part

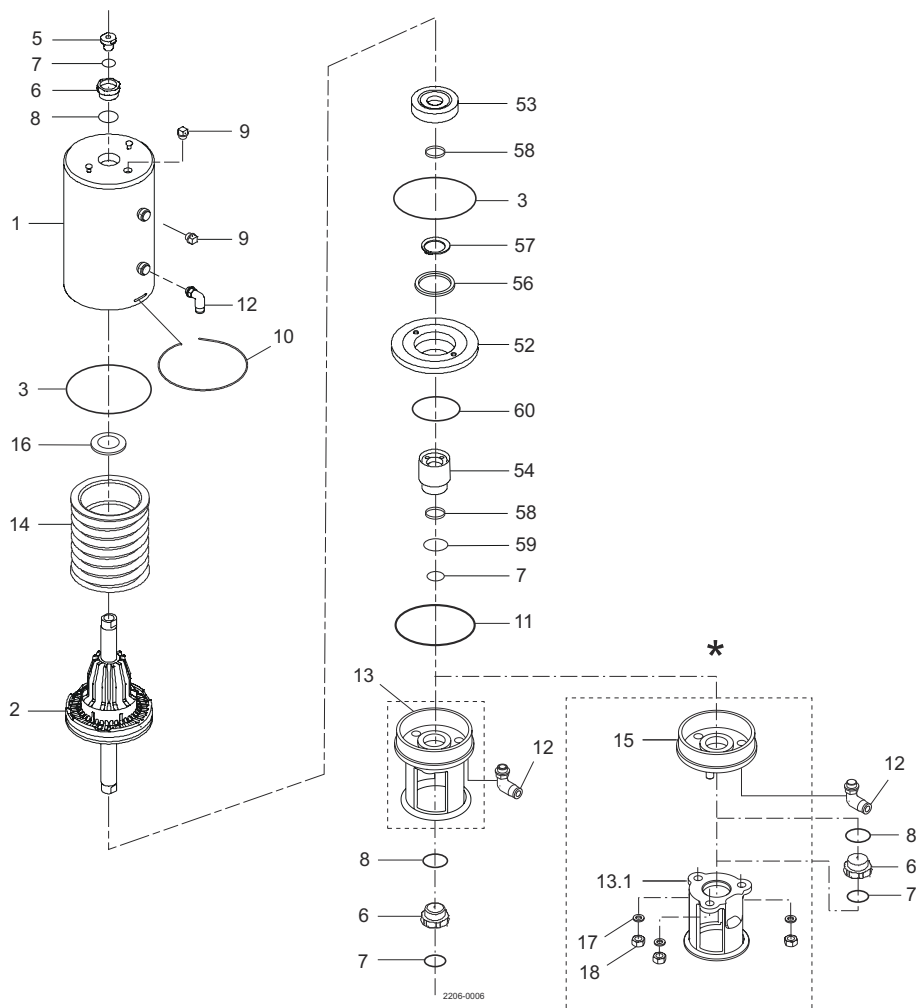

6.9 Dismantling of change-over (NO) maintainable actuator

NOTE

Study the instructions carefully.

The item refer to *Parts Lists and Exploded Views* on page 63.

Changing of wear parts

- 1 Rotate cylinder (1).
- 2 Remove lock wire (10) and pull away cylinder (1).
This can be done by careful using air on fitting (12).
- 3 Remove O-ring (11) from bottom (15).
- 4 Remove piston (2) together with support disk (16), thrust plate (53) and O-ring (3).
- 5 Remove spring assembly (14).
- 6 Unscrew nuts (18) and remove yoke (13).
- 7 Unscrew bottom bushing (6) and remove O-ring (8).
- 8 Remove seegering lock ring (57) using a seegering-tang tool.
- 9 Push piston (52) out of cylinder (1) using air on fitting (12) and remove O-rings (3+60) together with spacer ring (56).
Spacer ring (56) is only mounted on GR.3 actuator (diameter = $\varnothing 154$) type normally open.
- 10 Remove guide ring (58) and O-ring (7).

- 11 Guide (54) is screwed on top of cylinder (1) and should only be dismantled if guide (54) is broken.

If guide (54) has to be dismantled loosen nut (55). With a special tool it now is possible to dismantle guide (54). This is shown in [Changing pneumatic movement on fully maintainable actuator \(NC/NO\)](#) on page 57 step 2.

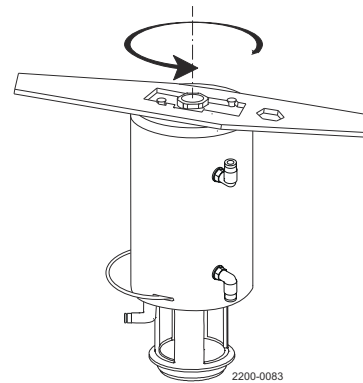

Rotate cylinder with service tool!

56) Only for shut off valves (not mounted in actuator for change-over valves)

59) No wear part

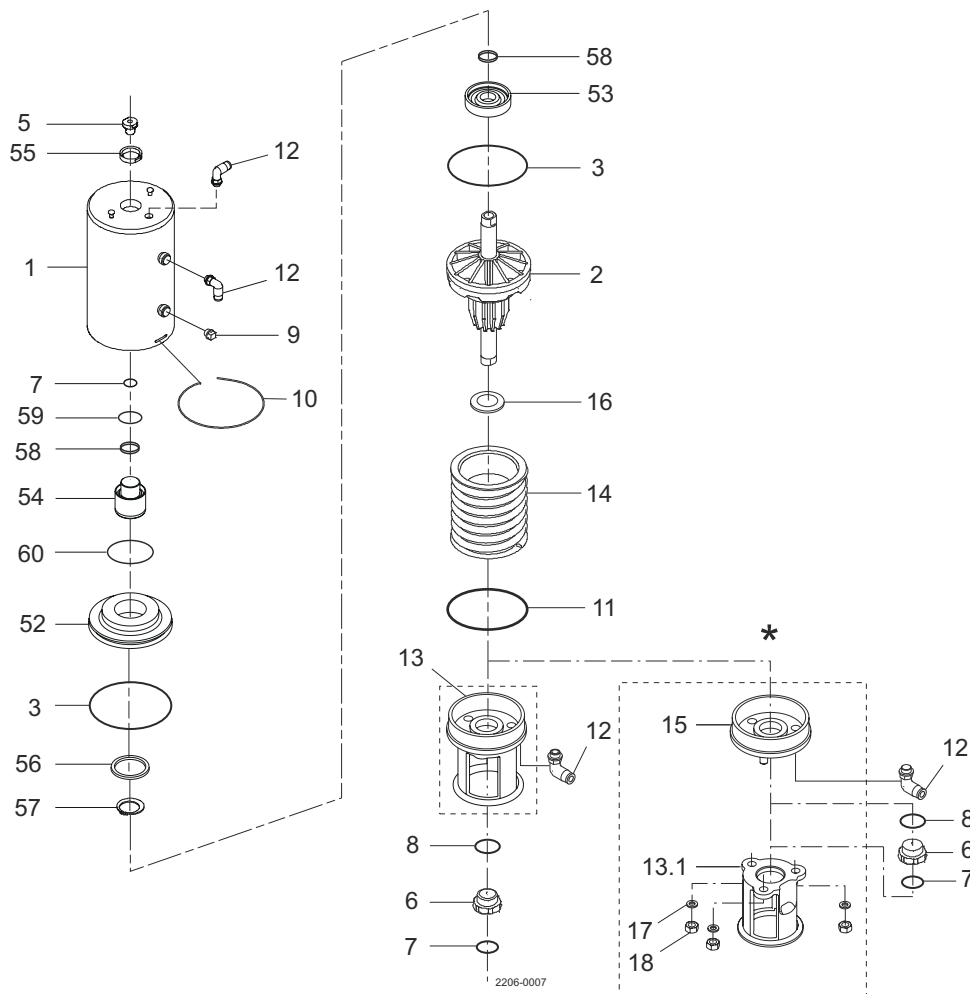

6.10 Assembly of maintainable actuator

Reverse order of *Dismantling of (NC) maintainable actuator* on page 52.

Reverse order of *Dismantling of change-over (NO) maintainable actuator* on page 54.

6.11 Changing pneumatic movement on fully maintainable actuator (NC/NO)

Before dismantling check that the actuator is not marked with a warning.

1. Rotate cylinder.
2. Remove lock wire and pull away cylinder
3. Reverse piston and spring assembly.
4. Reverse adapter, air fitting and plug to opposite end.
5. Reassemble in reverse order (3 to 1).

NC = Pneumatic movement - upwards

NO = Pneumatic movement - downwards

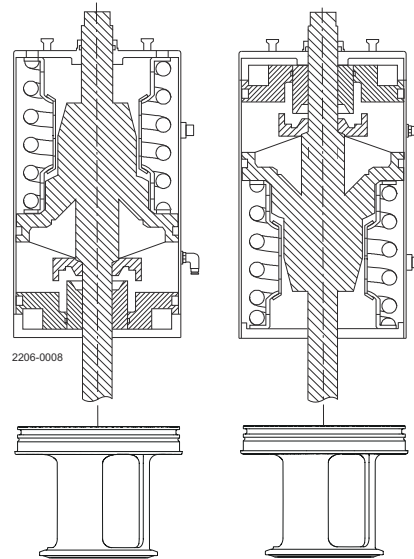

1

Actuator for the shut-off valves can not be reversed as it only is possible to operate in NC position.

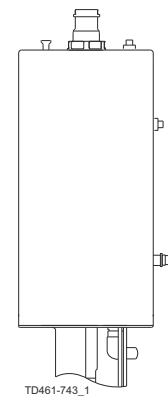

Actuator for the change-over valves can be reversed from NC to NO and from NO to NC.

See [Dismantling of \(NC\) maintainable actuator](#) on page 52 and [Dismantling of change-over \(NO\) maintainable actuator](#) on page 54.

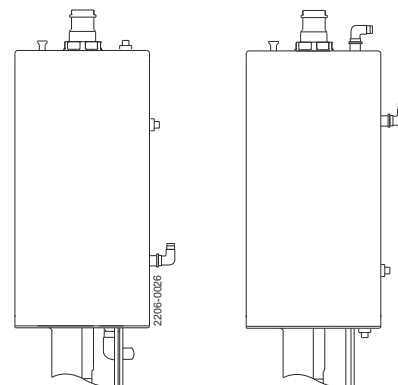

2

Reversing maintable actuator operation can be done by reversing parts inside the actuator. It is necessary to use a special "SSV Two step guide tool" (see step 3) and a "turning tool" (item no. 3135302191) for mounting the guide (54).

- a) Fit the "SSV Two step guide tool" in a vice
- b) Fit O-ring (59) in guide (54) and by hand screw it in cylinder (1)
- c) Fit "turning tool" on top of cylinder (1) and tighten (torque 15 - 20 Nm)

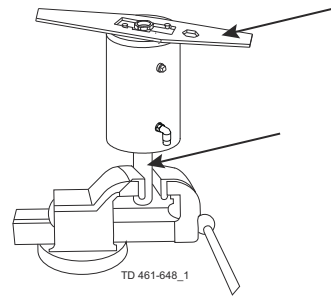

3135302191

Two step guide tool

3

Drawing of "SSV Two step mounting tool"

- a) Use $\varnothing 32$ mm bar and drill two $\varnothing 4$ holes in a diameter $\varnothing 26$ mm. (The depth of $\varnothing 4$ holes should be approx 6 mm)
- b) Edges on $\varnothing 32$ bar has to be min. R0.5 so it can fit into guide (54)
- c) Use $\varnothing 4$ mm bar with a length of approx 10 mm
- d) Apply loctite 270 or 638 and fit the two $\varnothing 4$ pins so length are according to drawing

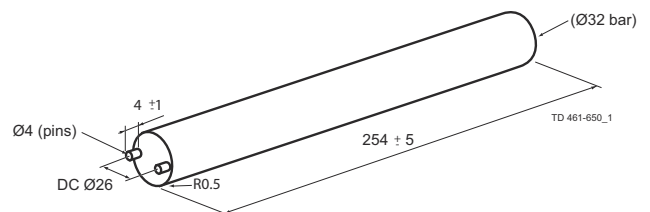

7 Technical Data

NOTE

Technical data must be observed during installation, operation and maintenance.
All personnel should be informed about the technical data.

7.1 Technical Data

Temperature	
Temperature range	-10 °C to +140 °C / 14 °F to +284 °F (EPDM)
Pressure	
Max. product pressure:	1000 kPa (10 bar) / 145 psi
Min. product pressure:	Full vacuum (depending on valve specifications)
Air pressure, actuator:	500 to 700 kPa (5 to 7 bar) / 72.5 to 101.5 psi

7.2 Physical Data

Materials	
Product wetted steel parts:	1.4404 (316L)
Other steel parts:	1.4301 (304)
Plug seal:	PTFE (TR2) (standard)
Optional plug seal:	EPDM, HNBR or FPM
External surface finish:	Semi-bright (blasted)
Internal surface finish:	Bright (polished), Ra < 0.8 µm / Ra < 32 µinch
Other product wetted seals:	EPDM (standard)
Optional product wetted seals:	HNBR and FPM
Other seals:	NBR

Weight (kg)

Nominal size	Inch Tubes DN/OD					DIN tubes DN					High pressure			
											Inch tubes DN/OD		DIN tubes DN	
	38	51	63.5	76.1	101.6	40	50	65	80	100	51	635	50	65
Shut-off	7	7.3	8.3	14.4	16.7	7	7.3	8.3	14.9	16.7	8.6	9.6	8.6	9.6
Change-over valve	8	8.9	10.3	17	21	8.2	8.9	10.5	17.9	21	10.2	11.6	10.2	11.6

Weight (lb)

Nominal size	1.5"	2"	2.5"	3"	4"	High pressure	
						2"	2.5"
Shut off	15.4	16.1	18.3	31.7	36.8	19.0	21.2
Change-over valve	17.6	19.6	22.7	37.5	46.3	22.5	25.6

This page is intentionally left blank.

8 Spare Parts

For every delivered Alfa Laval Product, a spare part list is available.

This spare part list contains a range of the most common wear parts for the machinery. If any component not mentioned is required, please contact your local Alfa Laval representative for availability.

You can find our spare part catalogue at <https://hygienicfluidhandling-catalogue.alfalaval.com>.

Always use Alfa Laval genuine spare parts. The warranty of Alfa Laval products is dependent on use of Alfa Laval genuine spare parts.

8.1 Ordering Spare Parts

When ordering spare parts, please always state:

1. Serial number (if available)
2. Item number/spare part number (if available)
3. Capacity or other relevant identification

8.2 Alfa Laval Service

Alfa Laval is represented in all larger countries of the world.

Do not hesitate to contact your local Alfa Laval representative, with any questions or requirement of spare parts for Alfa Laval equipment.

8.3 Warranty - Definition



The rules of Intended use are absolute. Use of the supplied Alfa Laval product is allowed only when in compliance with the technical data supplied with the Intended use.

Differing utilisation, other than agreed with Alfa Laval Kolding A/S, exclude any liability and warranty.

No modification or alteration of the supplied Alfa Laval product is allowed, unless explicit permission is granted by Alfa Laval Kolding A/S.



Liability and warranty are excluded:

- If advice and instruction of operating instructions are ignored
- For incorrect operation or for insufficient maintenance of the supplied Alfa Laval product
- For any kind of change of function of the supplied Alfa Laval product without prior written agreement by Alfa Laval Kolding A/S
- If supplied Alfa Laval product is modified by non-authorized persons
- If using the supplied Alfa Laval product without attention of appropriate safety regulations, (see [Safety](#) on page 7)
- If protection equipment is not used and vessel process / ancillary equipment is not brought to a standstill
- If the supplied Alfa Laval product and ancillary parts are not properly maintained (to be executed in intervals and including fitting of prescribed replacement parts)

When exchanging parts, only original replacement parts, released from the manufacturer, must be used.

9 Parts Lists and Exploded Views

9.1 Drawings

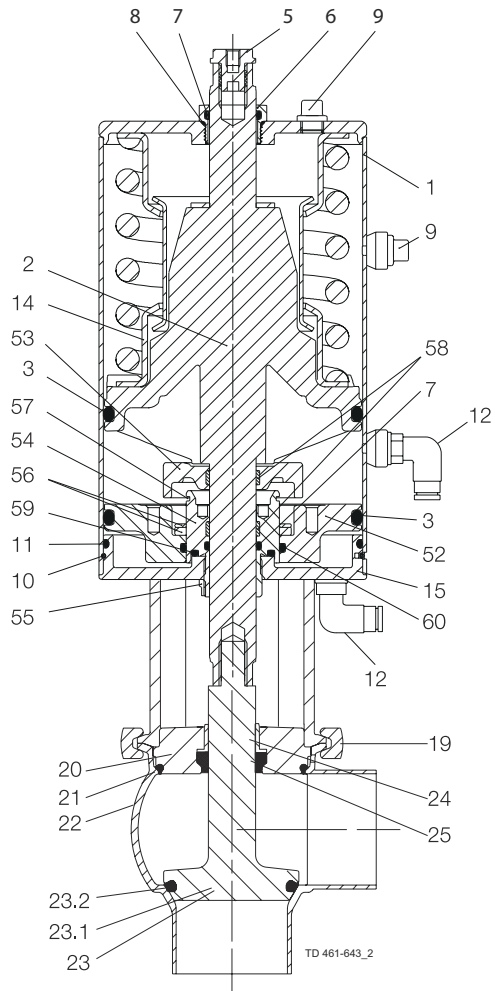

Shut-off valve

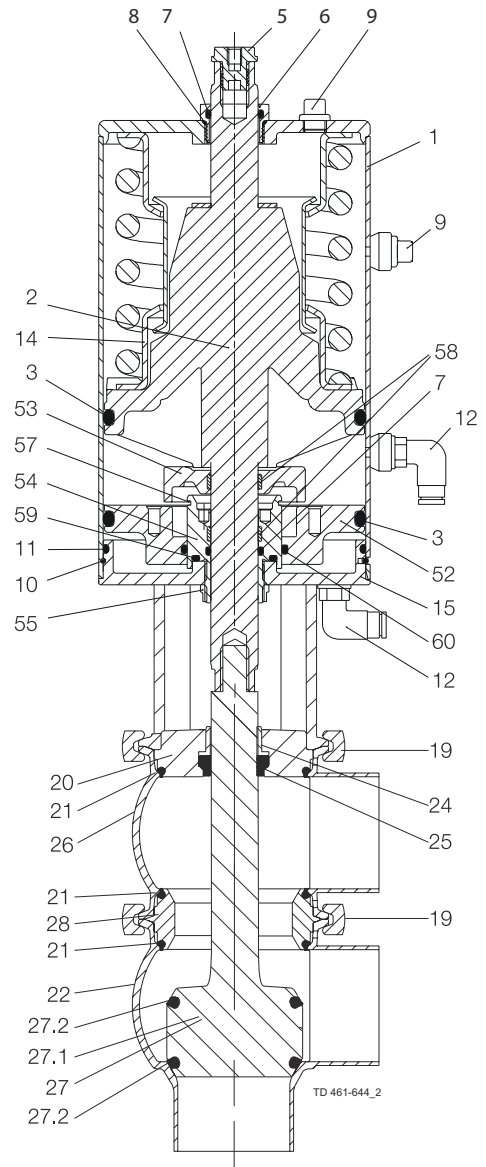

Change-over valve

9.2 Unique Single Seat Valve - Two Step 38-101.6 mm - shut-off valve

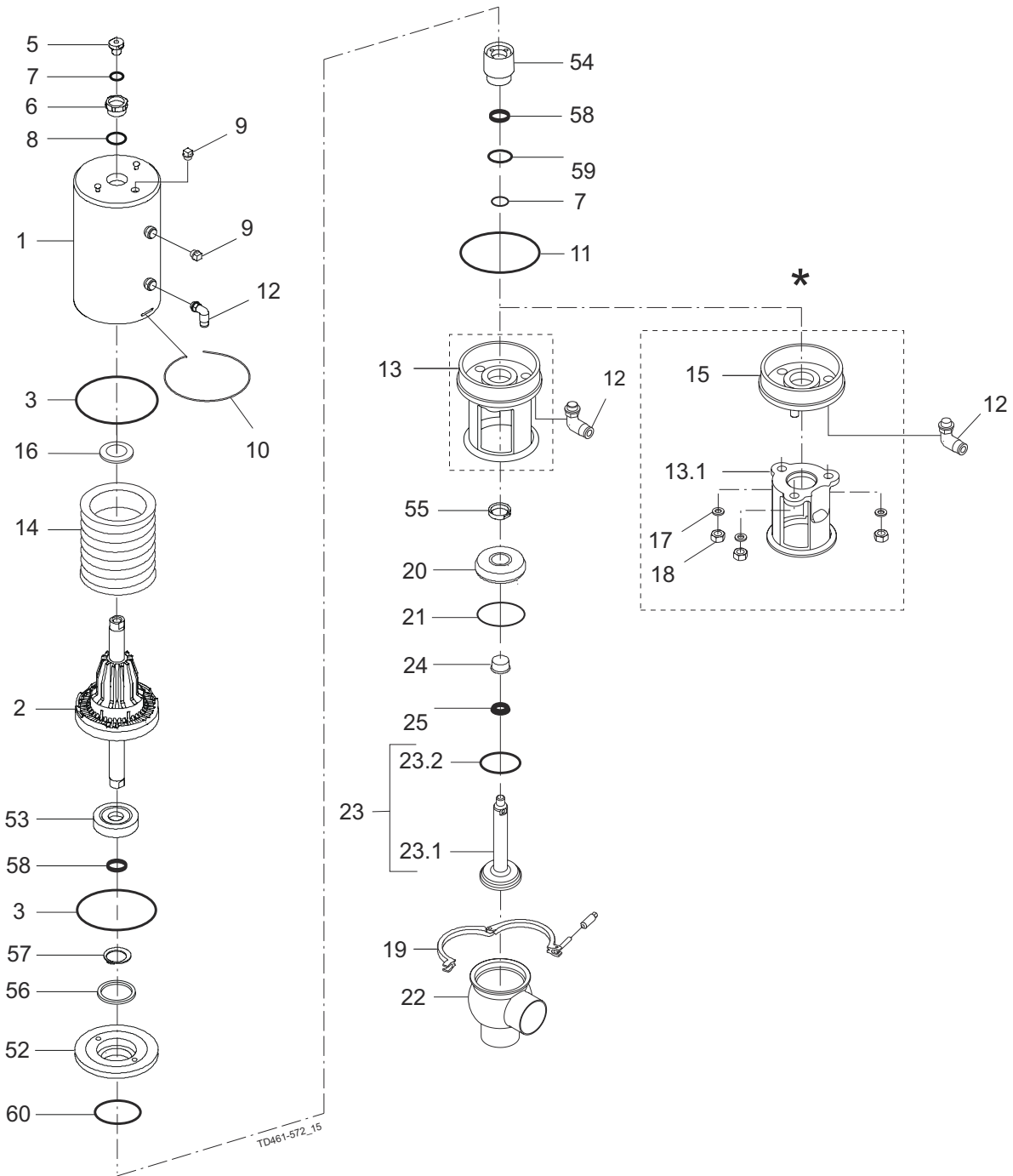

*) "Remove yoke with bolts" version, produced from 2006 to June 2016.
 Replaced by "yoke without bolts" (13).

Pos.	Qty.	Denomination
		Actuator, complete
1	1	Cylinder
2	1	Piston
3	2	O-ring
5	1	Adapter
6	1	Bushing
7	2	O-ring
8	1	O-ring
9	2	Plug
10	1	Lock wire
11	1	O-ring
12	2	Air fitting
13	1	Yoke without bolts
13.1	1	Yoke
14	1	Spring assembly
15	1	Bottom
16	1	Support disc
17	3	Washer
18	3	Nut

Pos.	Qty.	Denomination
19	1	Clamp
20	1	Bonnet
21	1	O-ring
22	1	Valve body, lower
23	1	Plug, shut off
23.1	1	Plug, shut-off
23.2	1	Plug seal
24	1	Bushing
25	1	Lip seal
52	1	Piston
53	1	Thrust plate
54	1	Guide
55	1	Nut
56	1/2/3	Spacer
57	1	Lock ring
58	2	Guide ring
59	1	O-ring
60	1	O-ring

9.3 Unique Single Seat Valve - Two Step 38-101.6 mm - change -over valve

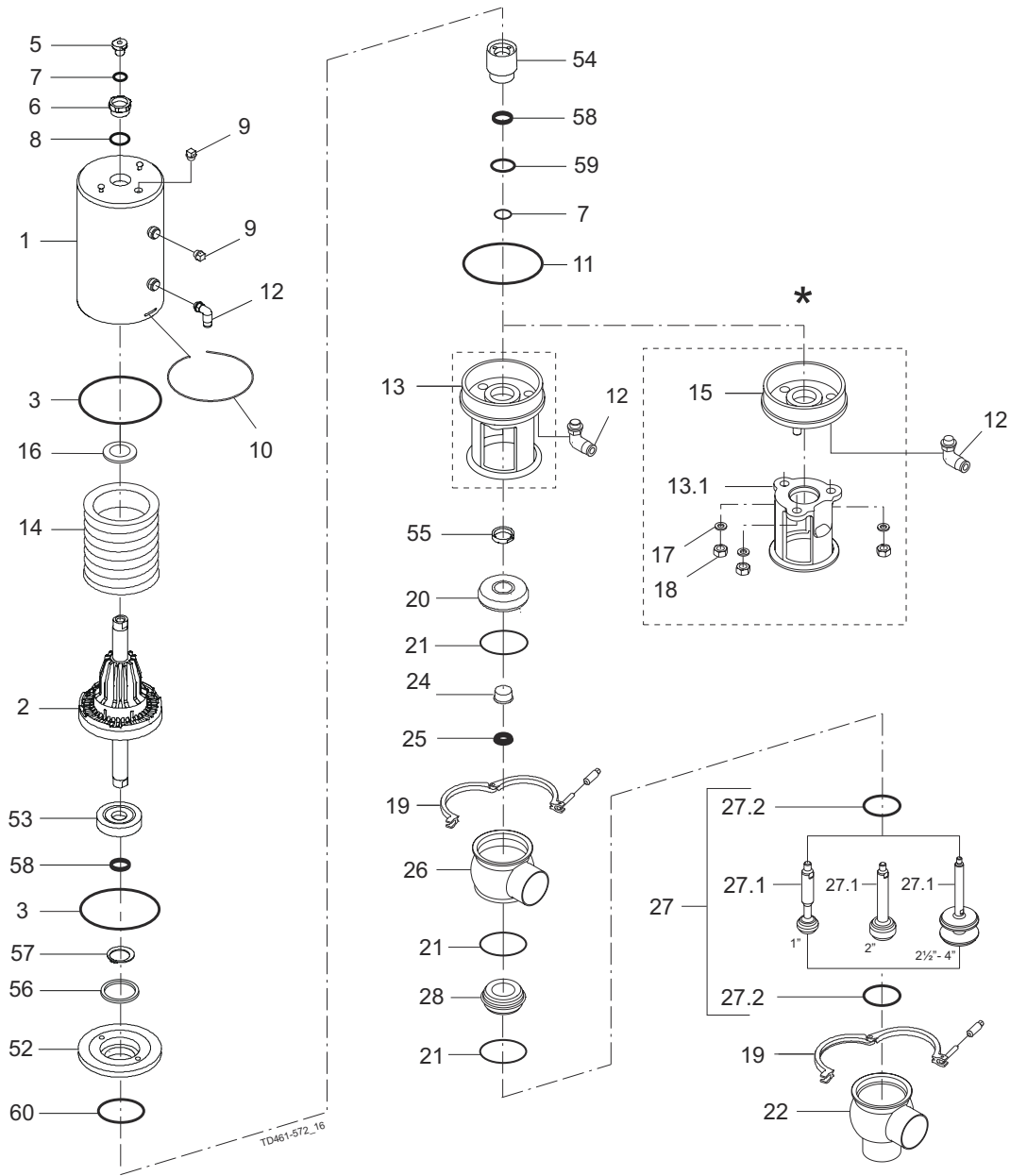

*) "Remove yoke with bolts" version, produced from 2006 to June 2016.
 Replaced by "yoke without bolts" (13).

Pos.	Qty.	Denomination
		Actuator, complete
1	1	Cylinder
2	1	Piston
3	2	O-ring
5	1	Adapter
6	1	Bushing
7	2	O-ring
8	1	O-ring
9	2	Plug
10	1	Lock wire
11	1	O-ring
12	2	Air fitting
13	1	Yoke without bolts
13.1	1	Yoke
14	1	Spring assembly
15	1	Bottom
16	1	Support disc
17	3	Washer
18	3	Nut

Pos.	Qty.	Denomination
19	1	Clamp
20	1	Bonnet
21	1	O-ring
22	1	Valve body, lower
24	1	Bushing
25	1	Lip seal
26	1	Valve body, upper
27	1	Plug, change over, complete
27.1	1	Plug, change over
27.2	2	Plug seal
52	1	Piston
53	1	Thrust plate
54	1	Guide
55	1	Nut
56	1/2/3	Spacer
57	1	Lock ring
58	2	Guide ring
59	1	O-ring
60	1	O-ring

9.4 Mounting tool - Unique SSV - Two Step maintainable actuator

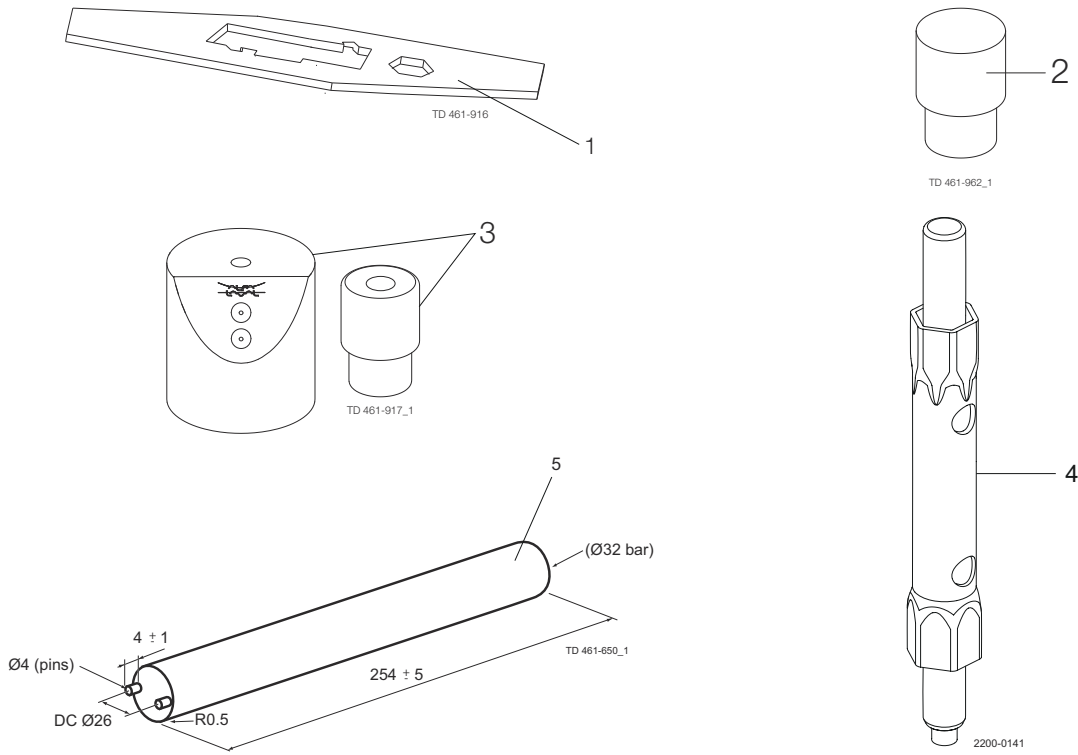

Pos.	Qty.	Denomination
1	1	Service tool only for maintainable actuator
2	1	Tool for bushing (pos. 24)
3	1	Mounting tool for elastomer plug seals

Pos.	Qty.	Denomination
4	1	Tool for actuator bushing (pos. 6)
5	1	SSV Two step mounting tool
101	1	Lifting tool complete
103	1	Clip