

Note that all unique customer requirements (i.e tolerance) need to be verified thru Alfa Laval.

CPF100  
Alloy 316  
S1,S2,S3,S4

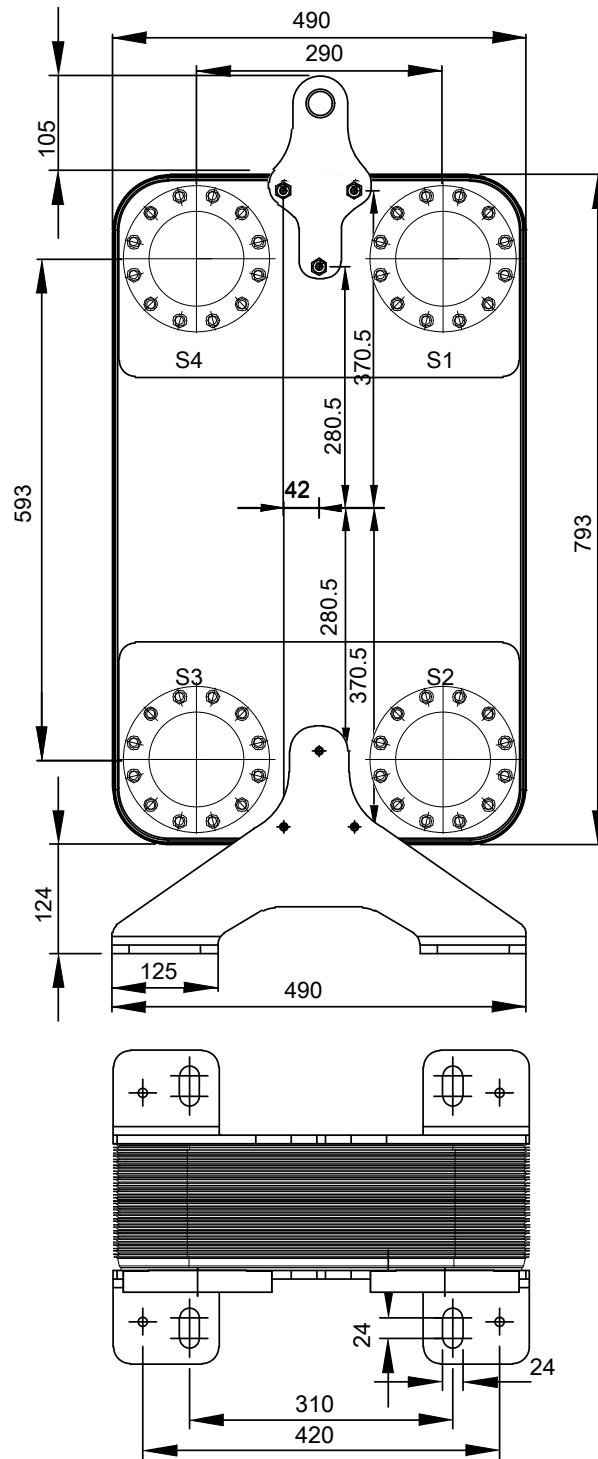
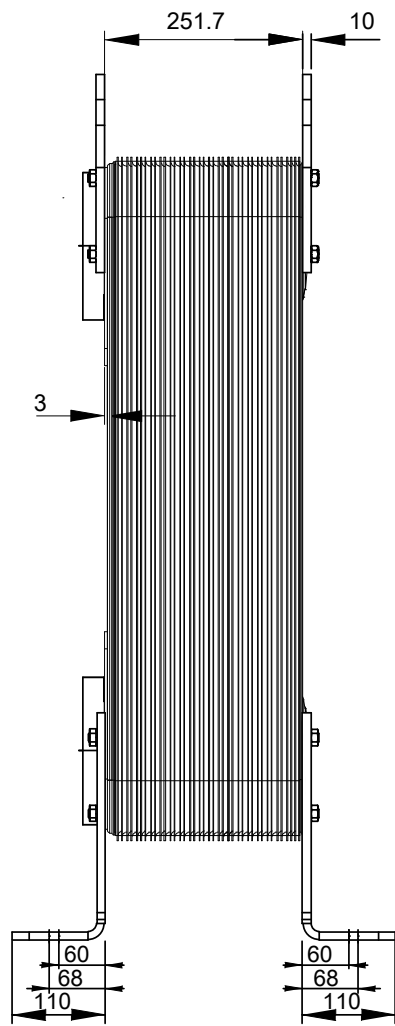
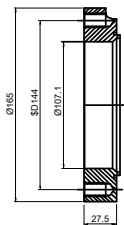

HEATING SURFACE  
NETWEIGHT 161.7 kg  
OPERATING WEIGHT kg  
PLATE MATERIAL ALLOY 316  
PLATE GROUPING 1\*54H/1\*55H

T1 T2 T3.1 T3.2 T4.1 T4.2 locations on back side  
correspond to S1 S2 S3.1 S3.2 S4.1 S4.2 on front side

ALL DIMENSIONS IN MILLIMETERS

SIDE	MEDIA	INLET	TEMP.	OUTLET	TEMP.	FLOW RATE	PRESSURE DROP	LIQUID VOL.
1		S1		S2				38.0 dm³
2		S3		S4				37.3 dm³

PRESSURE VESSEL APPROVAL

PED

CB410-110H (3075007659)

www.alfalaval.com

CUSTOMER NAME / REF. NO.

TOTAL LENGTH 471.7 mm  
TOTAL WIDTH 490.0 mm  
TOTAL HEIGHT 1022.0 mm

COMPANY / REF.



4/16/2024  
REV 0