

Note that all unique customer requirements (i.e tolerance) need to be verified thru Alfa Laval.

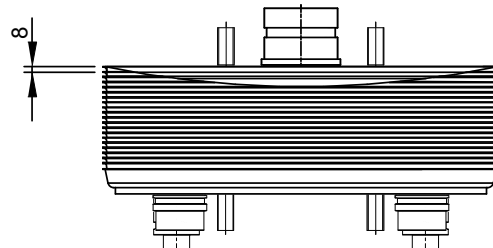
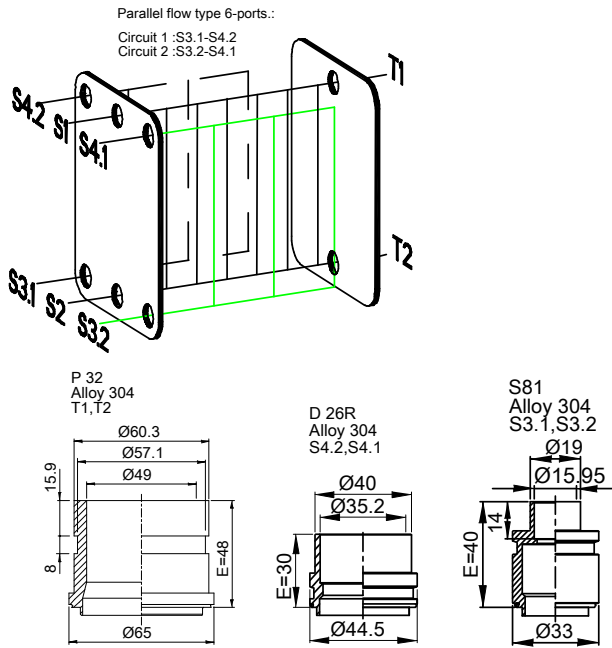

HEATING SURFACE
 NETWEIGHT 36.6 kg
 OPERATING WEIGHT kg
 PLATE MATERIAL ALLOY 316
 PLATE GROUPING 1*17AHR|1*17AHR/1*35AHR

ALL DIMENSIONS IN MILLIMETERS

SIDE	MEDIA	INLET	TEMP.	OUTLET	TEMP.	FLOW RATE	PRESSURE DROP	LIQUID VOL.
1		T1		T2				9.45 dm ³
2		S3.1,S3.2		S4.2,S4.1				4.08/4.08 dm ³

PRESSURE VESSEL APPROVAL UL/CRN

ACH240DQ-70AH-F (3075004366)

www.alfalaval.com

CUSTOMER NAME / REF. NO.	TOTAL LENGTH	248.0 mm
	TOTAL WIDTH	289.0 mm
	TOTAL HEIGHT	525.0 mm
COMPANY / REF.		
		4/16/2024 REV 0