

Note that all unique customer requirements (i.e tolerance) need to be verified thru Alfa Laval.

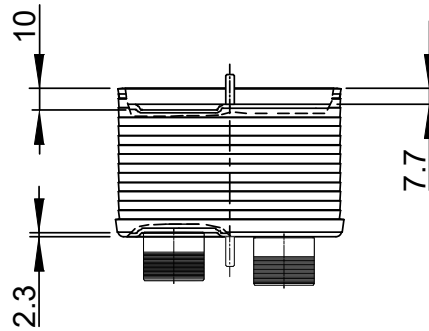
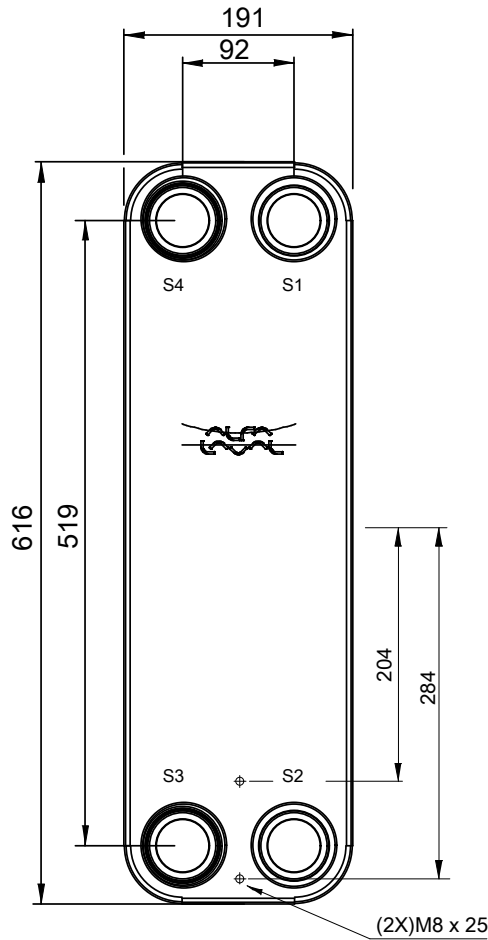
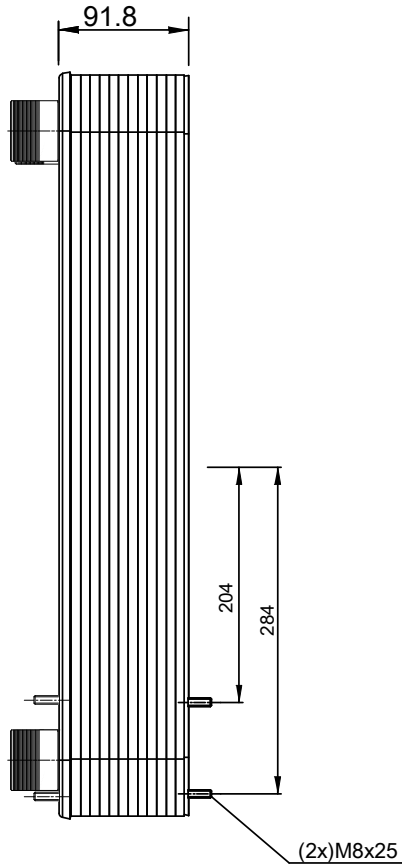
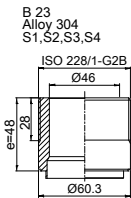

HEATING SURFACE
 NETWEIGHT 17.1 kg
 OPERATING WEIGHT kg
 PLATE MATERIAL ALLOY 316
 PLATE GROUPING 1*14L/1*15L

ALL DIMENSIONS IN MILLIMETERS

| SIDE | MEDIA | INLET | TEMP. | OUTLET | TEMP. | FLOW RATE | PRESSURE DROP | LIQUID VOL. |
|------|-------|-------|-------|--------|-------|-----------|---------------|----------------------|
| 1 | | S1 | | S2 | | | | 3.15 dm ³ |
| 2 | | S3 | | S4 | | | | 2.94 dm ³ |

PRESSURE VESSEL APPROVAL

PED



CB110-30L-F (3287118821)

www.alfalaval.com

CUSTOMER NAME / REF. NO.

TOTAL LENGTH 154.8 mm
 TOTAL WIDTH 191.0 mm
 TOTAL HEIGHT 616.0 mm

COMPANY / REF.



1/15/2024
 REV 0