

# Alfa Laval ThinkTop® V55

Sensing and control

---



Lit. Code

200013632-1-EN-GB

Instruction Manual

**Published by**  
Alfa Laval Kolding A/S  
Albuen 31  
DK-6000 Kolding, Denmark  
+45 79 32 22 00

**The original instructions are in English**

**© Alfa Laval AB 2024-10**

This document and its contents are subject to copyrights and other intellectual property rights owned by Alfa Laval AB (publ) or any of its affiliates (jointly "Alfa Laval"). No part of this document may be copied, re-produced or transmitted in any form or by any means, or for any purpose, without Alfa Laval's prior express written permission. Information and services provided in this document are made as a benefit and service to the user, and no representations or warranties are made about the accuracy or suitability of this information and these services for any purpose. All rights are reserved.

---

# Contents

<b>1</b>	<b>Declaration of Conformity</b> .....	<b>5</b>
1.1	EU Declaration of Conformity.....	5
1.2	UK Declaration of Conformity.....	6
<b>2</b>	<b>Safety</b> .....	<b>7</b>
2.1	Safety Signs.....	8
2.2	Safety Precautions.....	9
2.3	Warning Signs in Text.....	10
2.4	Requirements of Personnel.....	11
2.5	Recycling Information.....	12
<b>3</b>	<b>Introduction</b> .....	<b>13</b>
3.1	About ThinkTop.....	13
3.2	About this manual.....	13
<b>4</b>	<b>Installation</b> .....	<b>15</b>
4.1	Tools.....	15
4.2	Mechanical Installation.....	16
4.3	Pneumatic Installation.....	18
4.4	Electrical Installation, Digital-IO 24V.....	19
4.5	Electrical Installation, AS-interface.....	20
4.6	Electrical Installation, IO-link.....	21
4.7	Adapter Kit Installation.....	22
<b>5</b>	<b>Setup</b> .....	<b>23</b>
5.1	Auto Setup.....	23
5.2	Flex Setup.....	24
5.2.1	Perform Flex Setup.....	25
5.3	Live Setup.....	26
5.4	Options.....	27
<b>6</b>	<b>Troubleshooting</b> .....	<b>29</b>
6.1	Calculating the Error Code.....	29
6.2	Error Descriptions.....	30
6.3	Interpreting the Error Code Patterns.....	32
<b>7</b>	<b>Technical Data</b> .....	<b>33</b>
7.1	Technical Data.....	33
7.2	Operational Data.....	34
<b>8</b>	<b>Spare Parts</b> .....	<b>35</b>

8.1	Ordering Spare Parts.....	35
8.2	Alfa Laval Service.....	35
8.3	Warranty - definition.....	36
<b>9</b>	<b>Parts List and Exploded View.....</b>	<b>37</b>
9.1	ThinkTop V55.....	37

# 1 Declaration of Conformity

## 1.1 EU Declaration of Conformity

The designated company

Alfa Laval Kolding A/S, Albuen 31, DK-6000 Kolding, Denmark, +45 79 32 22 00

Company name, address and phone number

Hereby declare that

Top Unit for Valve Control and Indication

Designation

ThinkTop® V55

Type

Serial number from 0 to 10.000.000

is in conformity with the following directives with amendments:

- EMC Directive 2014/30/EU
- RoHS Directive 2011/65/EU and amendments

The person authorised to compile the technical file is the signer of this document.

Vice President BU Hygienic Fluid Handling  
Head of Product Management

Title

Mikkel Nordkvist

Name

Kolding, Denmark

Place

2024-06-01

Date (YYYY-MM-DD)



Signature

DoC Revison\_ 01\_062024



## 1.2 UK Declaration of Conformity

The designated company

Alfa Laval Kolding A/S, Albuen 31, DK-6000 Kolding, Denmark, +45 79 32 22 00

Company name, address and phone number

Hereby declare that

Top Unit for Valve Control and Indication

Designation

ThinkTop® V55

Type

Serial number from 0 to 10.000.000

is in conformity with the following directives with amendments:

- The Electromagnetic Compatibility Regulations 2016
- The Restriction of the Use of Certain Hazardous Substances in Electrical and Electronic Equipment Regulations 2012

Signed on behalf of: Alfa Laval Kolding A/S.

Vice President BU Hygienic Fluid Handling  
Head of Product Management

Title

Mikkel Nordkvist

Name

Kolding, Denmark

Place

2024-06-01

Date (YYYY-MM-DD)



Signature

DoC Revison\_ 01\_062024



## 2 Safety

### Read this first



This Instruction Manual is designed for operators and service engineers working with the supplied Alfa Laval product.

Operators must read and understand the **Safety, Installation and Operating** instructions of the supplied Alfa Laval product before carrying out any work or before you put the supplied Alfa Laval product into service!

Not following the instructions can result in serious accidents.

This documentation describes the authorized way to use the supplied Alfa Laval product. Alfa Laval will take no responsibility for injury or damage if the equipment is used in any other way.

This Instruction Manual is designed to provide the user with the information to perform tasks safely for all phases in the lifetime of the supplied Alfa Laval product.

The operator shall always read the chapter **Safety** first. Hereafter the operator can skip to the relevant section for the task to be carried out or for the information needed.

**Always** read the chapter **Technical Data** thoroughly.

This is the complete Instruction Manual for the supplied Alfa Laval product.



#### NOTE

The illustrations and specifications in this Instruction Manual were effective at the date of printing. However, as continuous improvements are our policy, we reserve the right to alter or modify the Instruction Manual without prior notice or any obligation.

The English version of the Instruction Manual is the original manual. Alfa Laval cannot be held responsible for incorrect translations. In case of doubt, the English version applies.

## 2.1 Safety Signs

### Warning Signs





	General warning.
	Electricity.
	Corrosive substance.







## 2.2 Safety Precautions

All warnings in the manual are summarised on this page. Pay special attention to the instructions below so that severe personal injury and/or damage to the supplied Alfa Laval product is avoided.

### Installation

	<p><b>Always</b> read the technical data thoroughly</p> <p><b>Never</b> install the ThinkTop before the valve or relay are in a safe position</p>
	<p>If welding close to the ThinkTop: <b>Always</b> perform earthing close to the welding area</p> <p>Disconnect the ThinkTop</p>
	<p><b>Always</b> ensure the ThinkTop is electrically connected by authorised personnel</p> <p>The ThinkTop must be installed in an inherently safe circuit, according to the corresponding regulations.</p>
	<p>The Valve Controller is primarily for indoor mounting – if mounted outside - it must be protected from sunlight.</p>

### Maintenance

	<p><b>Always</b> read the technical data carefully.</p> <p><b>Always</b> fit the seals between the valve and ThinkTop correctly.</p>
	<p><b>Never</b> install the ThinkTop before the valve or relay are in a safe position.</p>
	<p><b>Never</b> service the ThinkTop with the valve/actuator under pressure.</p>
	<p><b>Never</b> clean the ThinkTop with high pressure cleaning equipment.</p>
	<p><b>Never</b> use cleaning agents when cleaning the ThinkTop. Check with cleaning agent supplier.</p>

## 2.3 Warning Signs in Text

Pay attention to the safety instructions in this Instruction Manual.

Below are definitions of the four grades of warning signs used in the text where there is a risk for injury to personnel or damage to the supplied Alfa Laval product.

 **DANGER**

Indicates an imminently hazardous situation which, if not avoided, will result in death or serious injury.

 **WARNING**

Indicates a potentially hazardous situation which, if not avoided, could result in death or serious injury.

 **CAUTION**

Indicates a potentially hazardous situation which, if not avoided, may result in minor or moderate damage to the supplied Alfa Laval product.

 **NOTE**

Indicates important information to simplify or clarify procedures.

## 2.4 Requirements of Personnel

### Operators

The operators shall read and understand this Instruction Manual.

### Maintenance personnel

The maintenance personnel shall read and understand this Instruction Manual. The maintenance personnel or technicians shall be skilled within the field required to carry out the maintenance work safely.

### Trainees

Trainees can perform tasks under the supervision of an experienced employee.

### People in general

The public shall not have access to the supplied Alfa Laval product.

In some cases, specially skilled personnel may need to be hired (i.e. electricians, welders). In some cases the personnel has to be certified according to local regulations with experience of similar types of work.

## 2.5 Recycling Information

### Unpacking

Packing material may consist of wood, plastics, cardboard boxes and in some cases metal straps.

	<ul style="list-style-type: none"> <li>• Wood and cardboard boxes can be reused, recycled or used for energy recovery</li> <li>• Plastics should be recycled or burnt at a licensed waste incineration plant</li> <li>• Metal straps should be sent for material recycling</li> </ul>
---	---

### Maintenance

During maintenance, oil (if used) and wear parts in the supplied Alfa Laval product should be replaced.

- Oil and all non-metal wear parts must be disposed of in accordance with local regulations
- Rubber and plastics should be burnt at a licensed waste incineration plant. If not available they should be disposed of in accordance with local regulations
- Bearings and other metal parts should be sent to a licensed handler for material recycling
- Seal rings and friction linings should be disposed of to a licensed land fill site. Check your local regulations
- All metal parts should be sent for material recycling
- Worn out or defected electronic parts should be sent to a licensed handler for material recycling

### Scrapping

At end of use, the equipment must be recycled in accordance with the relevant local regulations. Besides the equipment itself, any hazardous residues from the process liquid must be considered and dealt with in a proper manner. When in doubt, or in the absence of local regulations, please contact your local Alfa Laval sales company.

### How to contact Alfa Laval

Contact details for all countries are continually updated on our website.

Please visit [www.alfalaval.com](http://www.alfalaval.com) to access the information directly.

## 3 Introduction

The Alfa Laval ThinkTop V55 is a slimmer, smarter, one-size-fits-all sensing and control unit for diaphragm valves used in the pharmaceutical, biotech, and next-generation food industries.

Built on the reliable Alfa Laval ThinkTop V-series platform, this valve control unit is trusted by dairy, food, beverage, and brewery manufacturers worldwide for its simplified setup, live replacement and unmatched peace of mind.

### 3.1 About ThinkTop

ThinkTop is a valve-top control unit that provides surveillance and control of valves during the fluid handling process. The control unit has been developed with user friendliness and robustness in mind.

ThinkTop comes with a control board for connection to any PLC system. There are three types of communication interfaces available:

- Digital I/O 24 VDC
- AS-Interface v3.0
- AS-I v2.11 and IO-link

When the ThinkTop receives a signal from the PLC system to open the valve, a built-in solenoid valve shifts the connected valve into position. The position is detected through a sensor target attached to the valve stem through a touch-free sensor system. The position is then evaluated and if valid, the corresponding feedback is returned to the automation system via the communication interface.

#### V55 series

The ThinkTop V55 features a compact housing with the same functionality as the ThinkTop V50.

The product fits the SS/SL actuator of all sizes of the Unique DV-ST Ultrapure diaphragm valves.

The product can also be fitted to the Unique Small Single Seat Valve (Unique SSSV) and Unique Vacuum Breaker Valve using the dedicated adapter kit.

### 3.2 About this manual

In this manual, you will find detailed descriptions of how to install and setup the different ThinkTop variants as well as detailed information about fault finding and maintenance. We recommend that you familiarize yourself with the content of the manual before you begin installation.

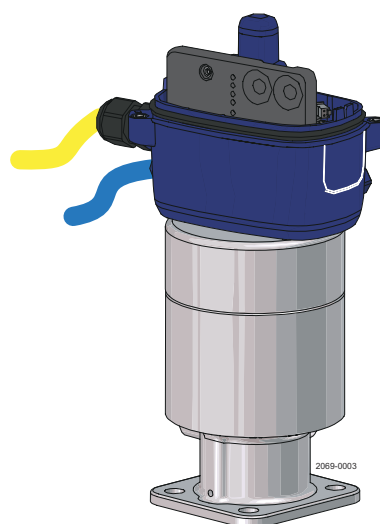





This page is intentionally left blank.

## 4 Installation

### 4.1 Tools

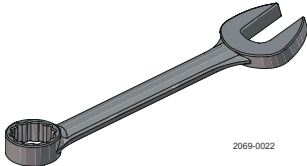
To carry out the installation, you need the following tools:

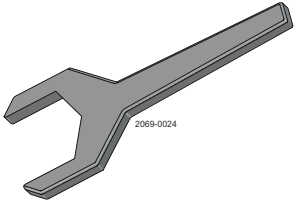
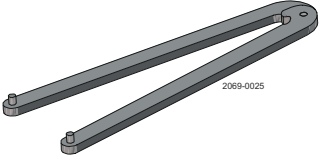
Tool	Size	Example
Hex key	2.5 mm	  2069-0021
Adjustable spanner or flat wrenches	7, 14, 19 mm	 2069-0022
Phillips screwdriver	Phillips 2	  2069-0023
Flat spanner (max thickness of 9 mm)	27 mm	 2069-0024
or		
Adjustable pin wrench		 2069-0025

When using wire end ferrules for ease of electrical installation it is recommended to choose ferrules with a barrel length of 10 mm to ensure full engagement in the terminals.

## 4.2 Mechanical Installation

Mechanical installation is a three-step process where you mount the adapter to the valve top, the sensor target to the actuator stem, and the ThinkTop on the adapter.

- 1 Fit the black adaptor to the valve.

(Remove the mechanical indication first, if present)

Tighten the adapter using a 27 mm spanner or an adjustable pin wrench. (4...5 Nm).

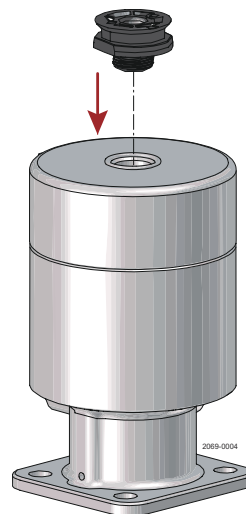

- 2 Fit the sensor target to the actuator stem.

Tighten the sensor target using a 2.5 mm hex key or 7 mm spanner. (1...2 Nm)

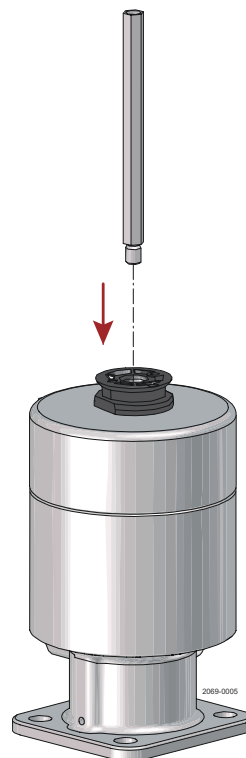



- 3** Mount the ThinkTop centred and flat against the adaptor while tightening the set screws.
- Use a 2.5 mm hex key to lightly tighten one of the two set screws.
- Tighten the second set screw (1...1.5 Nm).
- Tighten the first set screw (1...1.5 Nm)

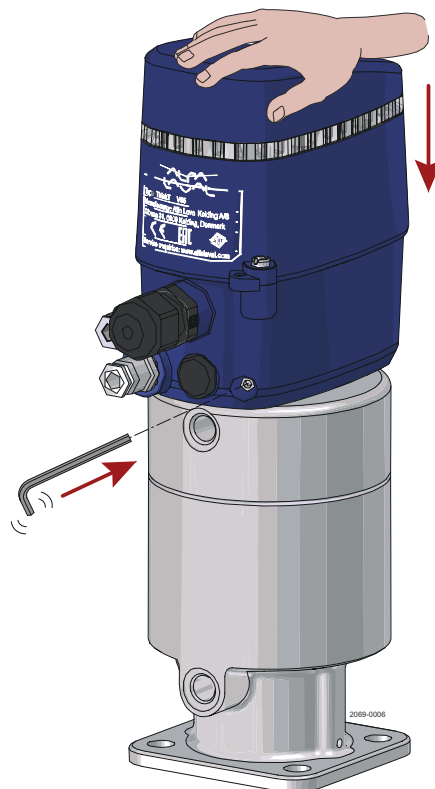

## 4.3 Pneumatic Installation

Before you begin the pneumatic installation, cut the hoses to the preferred length.

- 1 Connect the air hoses between the air connectors on the ThinkTop and the air ports on the valve.

Connect the supply air hose to the Air in connector and turn on the supply air.

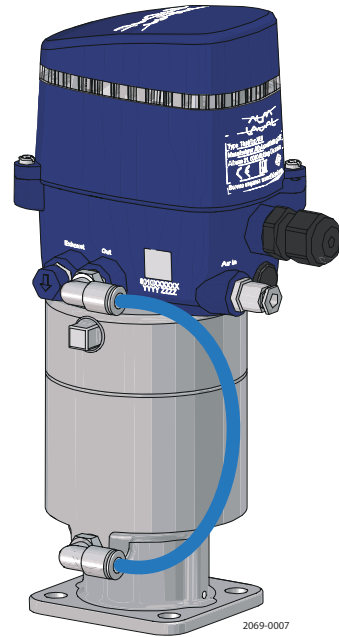

2069-0007

- 2 Verify that the air exhaust plug points downwards as indicated by the arrow to avoid water ingress in the pneumatic system. You can rotate the exhaust plug until it points in the right direction.

If the ThinkTop is oriented in a way which doesn't allow the exhaust plug to point down the part can be replaced with a downwards facing fitting instead.

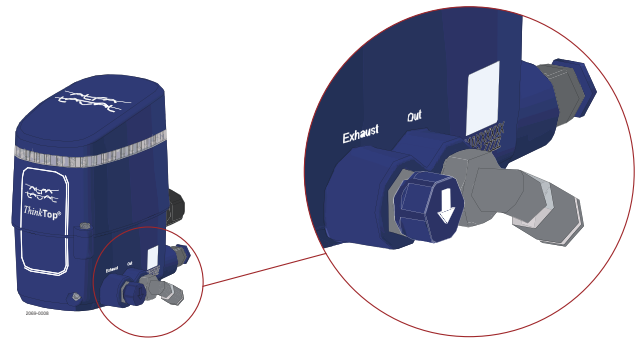

2069-0008

## 4.4 Electrical Installation, Digital-IO 24V

- 1
  - a) Loosen screws using Phillips 2 screwdriver.
  - b) Lift cover upwards to remove it from the base.
  - c) Install the cable and tighten the cable gland using a 19 mm wrench. (3 Nm).  
Or tighten the M12 connector using a 14 mm Wrench. (0.6...1.5 Nm).
  - d) Put the top cover back in place and tighten screws (0.5...1 Nm).
  - e) Turn on the power supply.  
If installed correctly, the light guide flashes green.

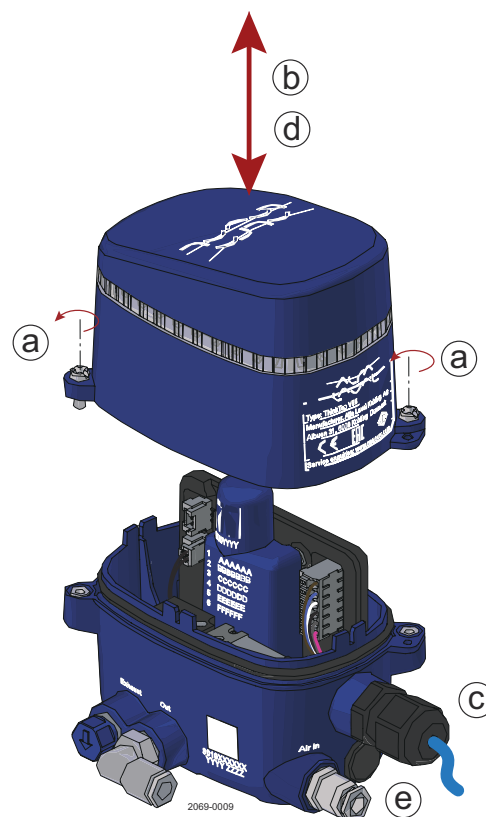

**Terminals V55 Digital-IO 24V**

1	Power supply	24V	(brown) (M12, pin 1)
2 <sup>1</sup>	Power supply	GND	(blue) (M12, pin 3 <sup>2</sup> )
3 <sup>1</sup>	out (PLC in)	Valve state	(white) (M12, pin 2 <sup>2</sup> )
4	out	Valve de-energised (DE-EN)	(black) (M12, pin 4)
5	out	Main valve energised (EN)	(grey) (M12, pin 5)
6	in	Solenoid valve 1 for main valve (SV1)	(pink) (M12, pin 6)

<sup>1</sup> Please be mindful of the difference between the number sequence of the control board terminal and the M12 plug pins.

<sup>2</sup> Please be mindful of the difference between the number sequence of the control board terminal and the M12 plug pins.

### CAUTION

When re-attaching the top cover, make sure gasket is not twisted or moved from gasket groove during the process.

## 4.5 Electrical Installation, AS-interface

- 1
  - a) Loosen screws using Phillips 2 screwdriver.
  - b) Lift cover upwards to remove it from the base.
  - c) To allocate an address, use your preferred addressing device. See the device manual for more information.
  - d) Install the cable and tighten the cable gland using a 19 mm wrench. (3 Nm).  
Or tighten the M12 connector using a 14 mm wrench (0.6...1.5 Nm).
  - e) Put the top cover back in place and tighten screws (0.5...1 Nm).
  - f) Turn on the power supply.  
If installed correctly, the light guide flashes green.

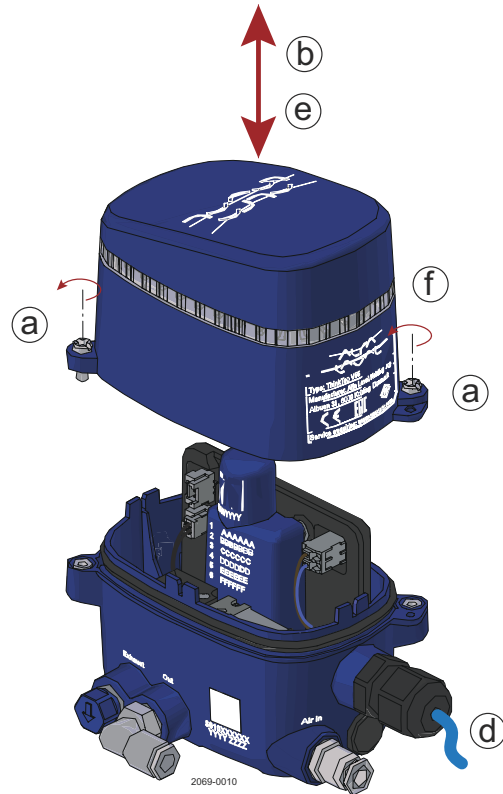

### Terminals V55 AS-interface

1	AS-i supply	AS-i +	(brown) (M12, pin 1)
2	AS-i supply	AS-i -	(blue) (M12, pin 3)

### CAUTION

When re-attaching the top cover, make sure gasket is not twisted or moved from gasket groove during the process.

## 4.6 Electrical Installation, IO-link

- 1
  - a) Loosen screws using a Phillips 2 screwdriver.
  - b) Lift cover upwards to remove it from the base.
  - c) Install the cable and tighten the M12 connector using a 14 mm wrench (0.6... 1.5 Nm).
  - d) Put the top cover back in place and tighten screws (0.5...1 Nm).
  - e) Turn on the power supply.  
If installed correctly, the light guide flashes green.

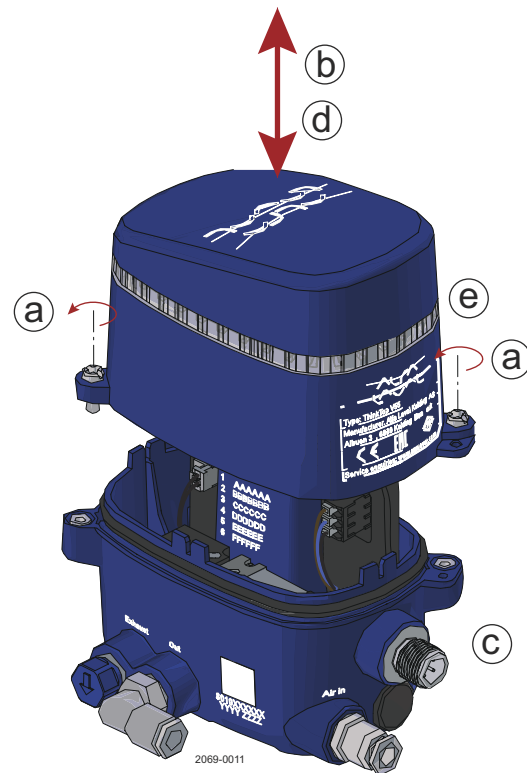

### Terminals V55 IO-Link

1	Power supply	L+ 24V	(brown) (M12, pin 1)
2	Power supply	L- GND	(blue) (M12, pin 3)
3	Signal	IO-Link	(black) (M12, pin 4)



When re-attaching the top cover, make sure gasket is not twisted or moved from gasket groove during the process.

## 4.7 Adapter Kit Installation

- 1 Mount the sensor target adapter to the actuator stem 1..1.5 Nm.  
An 11 mm key can be used for tightening.

**NOTE**

The adapter kit is compatible with the Small single seat valve and the Vacuum breaker valve.

The kit can be found in the Automation product catalogue under Sensing and control Automation Accessories.

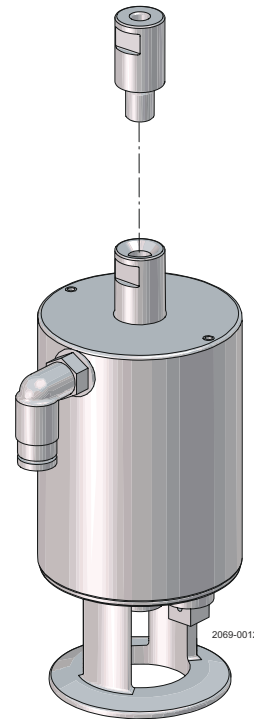

- 2 Mount the adapter to the actuator using 3 hex applying a moment of 1..1.5 Nm.  
Now installation is performed normally following the steps in [Mechanical Installation](#) on page 16.

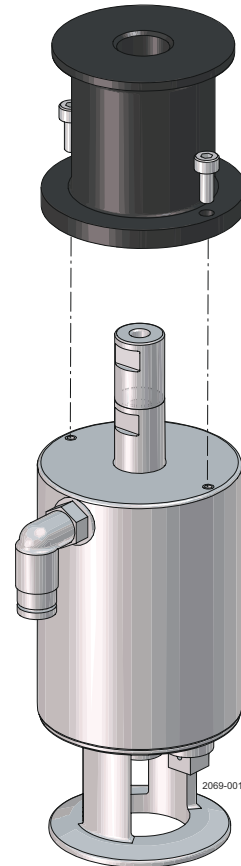

## 5 Setup

### 5.1 Auto Setup

Auto Setup activates all relevant solenoid valves and automatically completes the setup.

#### Perform Auto Setup

1 Remove the top cover by turning it anticlockwise and then lifting it upwards.

2 Press the SELECT button and then the ENTER button to initiate the Auto Setup functionality.

When Auto Setup has completed successfully, the following happens:

- The light guide lights steady green.
- The control unit is now in operation mode, and the surveillance mode feature is now activated.

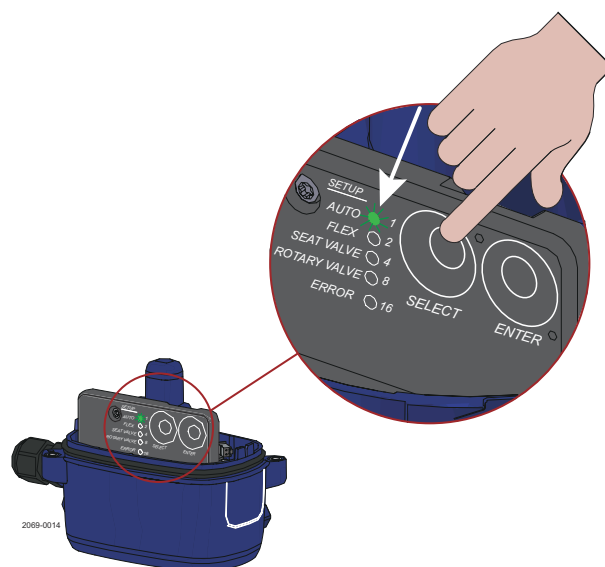

3 Put the top cover back in place.

4 Run an IO test to verify that the system returns the correct feedbacks.

#### Auto setup issues

- If Auto Setup returns an error, read the troubleshooting section for more information.
- If the IO test does not work as expected after completing Auto Setup, consider using Flex Setup.

#### Cancelling Auto Setup

Press the SELECT button, to cancel Auto Setup.

## 5.2 Flex Setup

Flex Setup allows the setup of any rising stem valve and is a flexible alternative to Auto Setup.

However, Flex Setup is not able to check for common installation mistakes. Flex Setup facilitates the detection and linking of valve functions and the related positions or sensor states to the outputs. Because it relies on additional operator input, the operator must be familiar with the content of the instruction manual.

### Use Flex Setup in the following situations:

- When using external solenoid valves that the ThinkTop does not have direct control of
- When adapting the ThinkTop to the closed / open valve position feedback paradigm

### The Flex Setup process varies depending on the ThinkTop and valve variants. The following describes a standard process:

- The process consists of a series of steps where each position of the valve is stored
- Each step is keyed to specific visual feedback
- The ThinkTop V55 has two setup steps
- All steps are generic and the labels that are used are only placeholders
- There is a 5 minute timeout in each setup. On timeout, the setup is cancelled, and no changes are saved

The valve can be manually controlled conveniently via the solenoid valves.

You can operate the solenoid valves manually by turning the white manual override screw feature anticlockwise.

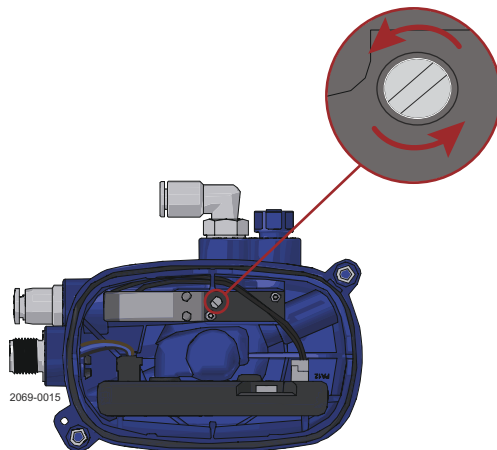



### 5.2.1 Perform Flex Setup

- 1 Remove the top cover.
- 2 Press the SELECT button two times to navigate to the Seat valve option, then press ENTER.
- 3 Store the valve positions.

**Green flashing** [De-energized position]

Position the valve in de-energized position.

Press ENTER to store.

**White flashing** [Main energized position]

Position the valve in main energized position.

Press ENTER to store.

When Flex Setup has completed:

- The light guide lights steady green.
- The control unit is in operation mode.

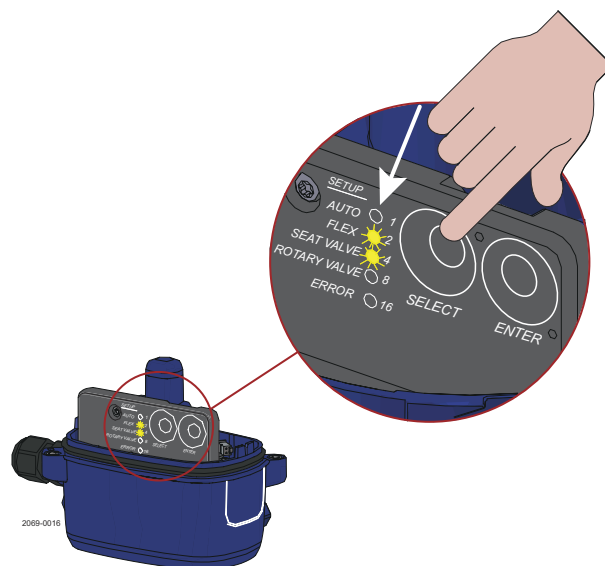

- 4 Re-install top cover.
- 5 Run an IO test to verify that the system returns the correct feedbacks.

## 5.3 Live Setup

Live Setup is especially suited for live commissioning and live replacement. Unlike Auto Setup, Live Setup does not automatically activate the solenoid valves. It waits for all the detected solenoid valves to be energized by the PLC, and then saves the related positions detected by the sensor system. The light guide lights steady green when setup is completed.

Live Setup is active out of the box until one of the setup options has been completed.

### Live commissioning

In applications where the mechanic, pneumatic and electrical installation has been completed, Live Setup can be carried out during regular IO test.

**! NOTE** Live setup needs time to confirm each valve position, so if the inputs are manually toggled from the control room, make sure to wait for the respective position feedback from Live setup or wait for 30s between each toggle if feedback is not available.

### Live replacement

Use Live Setup, when you need to replace a control unit during the production process and must wait for the solenoid valves to be activated. Live Setup will complete the setup when the solenoid valves has been activated at some point during the flow of the process.

During Live Setup, the feedback from the ThinkTop adapts to the registered position data from the initial movement of the valve.

### Completed Live Setup

When Live Setup has completed successfully, the following happens:

- The light guide lights steady green.
- The control unit is in operation mode and the following features are activated:
  - Surveillance mode

## 5.4 Options

The operational functionality of the ThinkTop can be further customized with the following options.

### Key lock

If you want to tamper proof the control board, the SELECT button can be locked by holding the ENTER button for 7s until the 4 first LED's in the array has come ON.

 **NOTE** The SELECT button is unlocked by repeating the process.

### Setup reset

Use the following process to reset the ThinkTop to factory default.

Hold both ENTER and SELECT for 7 seconds, until all LED's in the array are turned off.

The ThinkTop flashes green when reset.

### Check setup status

Use the following procedure to check how the ThinkTop was setup.

Press ENTER. The setup status is presented on the LED array.

The LEDs indicate the type of setup that was used and the type of valve the control unit expects to be mounted on.

 **NOTE** The Live setup status is presented by LED 1 and 2 together.

This page is intentionally left blank.

## 6 Troubleshooting

### 6.1 Calculating the Error Code

You need the error code to use the troubleshooting table. To determine the error code, you add the numbers to the right of the active LED's.

Example: The following control board shows 1 + 4 + 16, which results in error code #21.

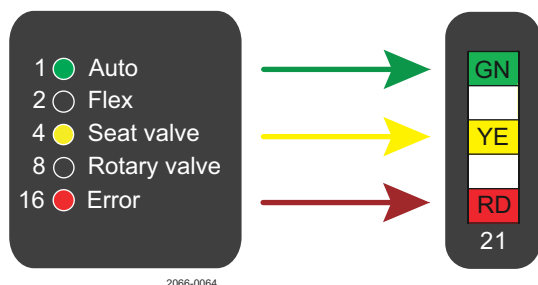

Alternatively, you can use the LED colour patterns to determine the error code. For more information, see [Interpreting the Error Code Patterns](#) on page 32.

#### Check latest error

If you are trying to resolve a periodic error, and the error code is not displayed during troubleshooting, you can press the ENTER button twice to view the latest error code.

## 6.2 Error Descriptions

#	Error description	Troubleshooting advice
15	Key lock active	The SELECT button is locked. It can be unlocked by holding the ENTER button for 7s until the 4 first LEDs has come ON.
16	Sensor target missing	Verify that the sensor target is installed correctly.
20	Position not reached	During operation, the sensor target or the seat lift sensor did not reach the intended position on time. <ul style="list-style-type: none"> <li>• Check the supply pressure at the unit is above the min. treshold of the valve actuator.</li> <li>• Check the performance of the process valve actuator</li> </ul> Verify that the following prerequisites for Auto Setup are met: <ul style="list-style-type: none"> <li>• The number of solenoid valves corresponds to the number of valve functions</li> <li>• The solenoid valve is not locked in manual override</li> <li>• Use Flex Setup if these prerequisites cannot be met</li> </ul> If Flex Setup cancels with this error, it indicates that identical position data has been detected for two or more steps. <ul style="list-style-type: none"> <li>• Retry Flex Setup (Press SELECT to skip unnecessary steps)</li> </ul>
21	Unexpected process valve movement	During operation the valve has moved away from the expected position. <ul style="list-style-type: none"> <li>• Check for manual override of solenoid valves</li> <li>• Check the operation of the solenoid valve. If air ventilates from both exhaust and output simultaneously, the SV might be stuck in an intermediate position</li> <li>• If duration of the error was very short it might be a pressure shock in the process valve</li> </ul>
23	Solenoid valve 1 missing	Solenoid valve 1 is not detected. <ul style="list-style-type: none"> <li>• Check the solenoid valve wiring</li> <li>• Rerun setup if the solenoid valve has been intentionally removed</li> </ul>
27	Output short circuit (Digital only)	An output short circuit is detected. <ul style="list-style-type: none"> <li>• Check the wiring for the digital outputs</li> </ul>
28	Setup aborted	Setup has been cancelled due to one of the following conditions: Timeout SELECT was pressed, or fault condition was detected. No changes are saved when setup cancels. <ul style="list-style-type: none"> <li>• Rerun setup</li> </ul>
29	Blocked button	A button is constantly pressed. <ul style="list-style-type: none"> <li>• Inspect the buttons</li> <li>• If the buttons look OK, the control board needs to be replaced</li> </ul>
30	Voltage Low (Digital version only)	Too low supply voltage has been detected. <ul style="list-style-type: none"> <li>• Verify that the voltage is above 21V</li> </ul>
30	Communication failure (IO-Link version only)	Communication with the IO-Link master is lost. The valve is returned to fail safe position. <ul style="list-style-type: none"> <li>• Check the cable connection between the ThinkTop and the IO-Link master</li> </ul>

<sup>1</sup> This event is not treated as an error.

#	Error description	Troubleshooting advice
31	Safety stop	<p>The sensor target has moved past the max. limit.</p> <p>The unit is locked in fail safe mode to protect the housing.</p> <ul style="list-style-type: none"> <li>• Verify that the actuator stroke length is compatible with the control unit</li> </ul> <p>The condition is reset on re-power.</p>
32 <sup>1</sup>	Pressure shock event (IO-Link version only)	<p>Small unexpected valve movement events are counted and logged in the Diagnostic log.</p> <p>Definition: Movement between 0.2-0.4 mm within 0.5s.</p> <p>It will not affect the valve state feedback nor will it give a red visual feedback.</p>

<sup>1</sup> This event is not treated as an error.





## 7 Technical Data

### NOTE

Technical data must be observed during installation, operation and maintenance.  
All personnel should be informed about the technical data.

### 7.1 Technical Data

Material	
Plastic parts	Nylon PA 12
Steel parts	1.4301 / 304
Gaskets	Nitril / NBR
Air fittings	Nickel plated / Nylon PA6
M12 chassis connector	Stainless steel / Gold plated pins
Environment	
Working temperature	-10 °C to +60 °C / +14 °F to +140 °F
Protection class (IP)	IP69K
Protection class (NEMA)	4, 4X and 6
Hazardous area	Not available yet ATEX and IEC-Ex
Control board	
Communication	See interfaces section
Sensor accuracy	± 0.1 mm / ± 0.04"
Mean Time To Failure (MTTF)	224 years
Approvals	UL/CSA Certificate: E174191
Solenoid valve	
Supply voltage	24 VDC ± 10%
Nominal power	0.3 W
Air supply	300-800 kPa (3-8 bar)
Type of solenoids	3/2-ways
Number of solenoids	0-1
Manual hold override	Yes
Air quality	Class 3,3,3 acc. DIN ISO 8573-1
Air pressure	6-8 bar
B10 data	5 million cycles
Recommendation	Operate once a month to prevent dry-out

**NOTE** Throughout this document, **SV** is used as an abbreviation for a solenoid valve.

Air fitting	
Threaded air fitting G1/8	ø6 mm (Rim blue) or 1/4" (Rim Grey)
Elbow push-in fittings	ø6 mm (Smooth rim) or 1/4" (Grooved rim)

**Cable connection**

Main cable gland entry Digital	M16 (ø4 - ø10 mm <sup>2</sup> ) (0.16" - 0.39")
Main cable gland entry AS-I	M16 (ø2 - ø7 mm <sup>2</sup> ) (0.08" - 0.28")
Max wire diameter	0.75 mm <sup>2</sup> (AWG20)

**M12 chassis connector**

AS-Interface V55	2 wire, 4-pin series
IO-Link interface V55	3 wire, 4-pin series
Digital interface V55	6 wire, 8-pin series

**Vibration**

Vibration	18 Hz-1kHz @ 7.54 g RMS
Shock	100 g

**Humidity**

Constant humidity	+40 °C / +140 °F, 21 days, 93% RH
Cyclic humidity	-25 °C / +55 °C (-13 °F / +131 °F), 93% RH, 12 cycles

**Accessories by functionality**

Valve "opening" speed reduction	0-100%. Outlet air fitting on ThinkTop
Valve "closing" speed reduction	0-100%. Inlet air fitting on actuator
Valve closing speed increase	Quick air exhaust, Ø 6 mm / Ø 0.24"

**7.2 Operational Data**

**ThinkTop LED indication**

ThinkTop features a 360-degree light guide. When the sensor target is within the respective setup position band, the corresponding colour lights up.



**Valve position**

	Actuator	<input checked="" type="checkbox"/> All De-energized	<input type="checkbox"/> Main valve open Energized
ThinkTop Mode	Factory setting	Green flashing	White flashing
	Operation	Green	White
	Not OK	Green/red flashing	White/red flashing

---

## 8 Spare Parts

For every delivered Alfa Laval Product, a spare part list is available.

This spare part list contains a range of the most common wear parts for the machinery. If any component not mentioned is required, please contact your local Alfa Laval representative for availability.

You can find our spare part catalogue at <https://hygienicfluidhandling-catalogue.alfalaval.com>.

**Always** use Alfa Laval genuine spare parts. The warranty of Alfa Laval products is dependent on use of Alfa Laval genuine spare parts.

### 8.1 Ordering Spare Parts

When ordering spare parts, please always state:

1. Serial number (if available)
2. Item number/spare part number (if available)
3. Capacity or other relevant identification

### 8.2 Alfa Laval Service

Alfa Laval is represented in all larger countries of the world.

Do not hesitate to contact your local Alfa Laval representative, with any questions or requirement of spare parts for Alfa Laval equipment.

## 8.3 Warranty - definition



The rules of Intended use are absolute. Use of the supplied Alfa Laval product is allowed only when in compliance with the technical data supplied with the Intended use.

Differing utilisation, other than agreed with Alfa Laval Kolding A/S, exclude any liability and warranty.

No modification or alteration of the supplied Alfa Laval product is allowed, unless explicit permission is granted by Alfa Laval Kolding A/S.



### Liability and warranty are excluded:

- If advice and instruction of operating instructions are ignored
- For incorrect operation or for insufficient maintenance of the supplied Alfa Laval product
- For any kind of change of function of the supplied Alfa Laval product without prior written agreement by Alfa Laval Kolding A/S
- If supplied Alfa Laval product is modified by non-authorised persons
- If using the supplied Alfa Laval product without attention of appropriate safety regulations. (See [Safety](#) on page 7)
- If protection equipment is not used and vessel process / ancillary equipment is not brought to a standstill
- If the supplied Alfa Laval product and ancillary parts are not properly maintained (to be executed in intervals and including fitting of prescribed replacement parts)

When exchanging parts, only original replacement parts, released from the manufacturer, must be used.

## 9 Parts List and Exploded View

### 9.1 ThinkTop V55

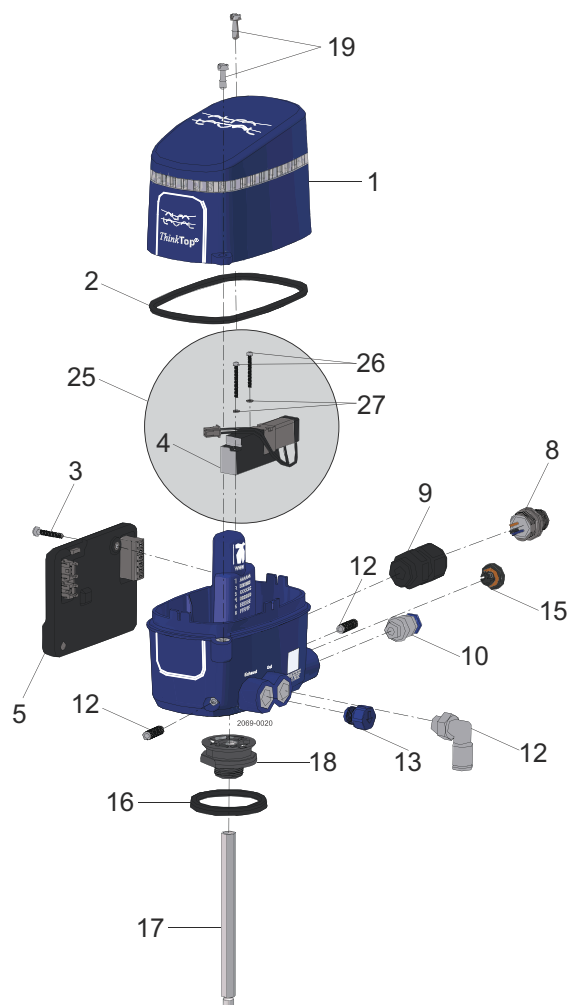

Pos.	Qty.	Denomination
1	1	Top cover, complete
2	1	Base seal
3	1	Screw Torx 10
4	1	Solenoid valve kit
5.1	1	Control board digital
5.2	1	Control board ASi 3.0
5.3	1	Control board IO-link
8.1	1	M12 plug, DIO, 8 pins/6 wires
8.2	1	M12 plug, ASi, 4 pins/2 wires
8.3	1	M12 plug, IO-link, 4 pins/3 wires
9.1	1	Cable gland, M16x1.5, Ø4.5-10
9.2	1	Cable gland, M16x1.5, Ø2-7mm
10.1	1	Air fitting, straight, 6mm

Pos.	Qty.	Denomination
10.2	1	Air fitting, straight, 1/4 inch
12.1	1	Air fitting angle, 6 mm
12.2	1	Air fitting, anglet, 1/4 inch
13	1	Exhaust plug
14	2	Screw set Hex 2.5
15	1	Gore vent
16	1	Lip seal
17	1	Sensor target
18	1	Adaptor
19	2	Screw M4 x11
25	1	Solenoid valve kit
26	2	Screw
27	2	Washer