

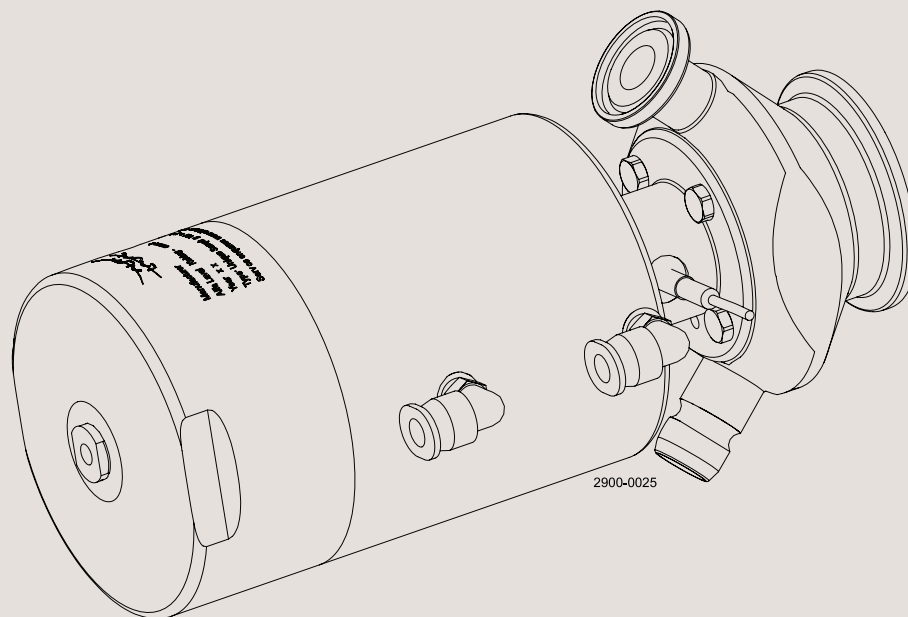

Instruction Manual

Unique Sampling Valve – Type P – Pneumatic Operated



ESE02212-EN8 2022-10

Original manual

The information herein is correct at the time of issue but may be subject to change without prior notice

1. Declarations of Conformity	4
2. Safety	6
2.1. Important information	6
2.2. Warning signs	6
2.3. Safety precautions	7
3. Installation	8
3.1. Unpacking/delivery	8
3.2. General installation	8
3.3. Valve body installation	9
3.4. Fitting of actuator - sizes 4 and 10	10
3.5. Fitting of actuator - size 25	12
3.6. Adjustment of valve	13
3.7. Installation of proximity switch (accessories)	14
3.8. Recycling information	14
4. Operation – Single Seat Valve	15
4.1. Operation	15
4.2. Sterilisation - single seat pneumatic actuator	16
4.3. Sampling - single seat pneumatic actuator	17
4.4. Troubleshooting	17
4.5. Recommended cleaning	18
5. Operation – Double Seat Valve	19
5.1. Operation	19
5.2. Sterilisation - double seat pneumatic actuator	20
5.3. Sampling - double seat pneumatic actuator	21
5.4. Troubleshooting	21
5.5. Recommended cleaning	22
6. Maintenance	23
6.1. General maintenance	23
6.2. Dismantling of valve	25
6.3. Valve assembly	25
6.4. Dismantling of single seat actuator	26
6.5. Assembly of single seat actuator	27
6.6. Dismantling of double seat actuator	28
6.7. Assembly of double seat actuator	33
7. Technical data	37
7.1. Technical data	37
8. Parts List and Service Kits	40
8.1. Actuator for USV size 4 double seat	40
8.2. Actuator for USV size 4 single seat	42
8.3. Actuator for USV size 10 double seat	44
8.4. Actuator for USV size 10 single seat	46
8.5. Actuator for USV size 25 double seat	48
8.6. Actuator for USV size 25 single seat	50

1 Declarations of Conformity

EU Declaration of Conformity

The Designated Company

Alfa Laval Kolding A/S, Albuen 31, DK-6000 Kolding, Denmark, +45 79 32 22 00

Company name, address and phone number

Hereby declare that

Unique Sampling Valve

Designation

Unique Sampling Valve Size 4 P, Unique Sampling Valve Size 10 P, Unique Sampling Valve Size 25 P

Type

is in conformity with the following directives with amendments:
- Machinery Directive 2006/42/EC

The person authorised to compile the technical file is the signer of this document.

Global Product Quality Manager

Title

Lars Kruse Andersen

Name

Kolding, Denmark

Place

2022-10-01

Date (YYYY-MM-DD)

Signature

This Declaration of Conformity replaces Declaration of Conformity dated 2016-06-01



1 Declarations of Conformity

UK Declaration of Conformity

The Designated Company

Alfa Laval Kolding A/S, Albuen 31, DK-6000 Kolding, Denmark, +45 79 32 22 00

Company name, address and phone number

Hereby declare that

Unique Sampling Valve

Designation

Unique Sampling Valve Size 4 P, Unique Sampling Valve Size 10 P, Unique Sampling Valve Size 25 P

Type

is in conformity with the following directives with amendments:
- The Supply of Machinery (Safety) Regulations 2008

Signed on behalf of: Alfa Laval Kolding A/S

Global Product Quality Manager

Title

Lars Kruse Andersen

Name

Kolding, Denmark

Place

2022-10-01

Date (YYYY-MM-DD)

Signature

DoC Revison_01_102022

**UK
CA**



2 Safety

*Unsafe practices and other important information are emphasised in this manual.
Warnings are emphasised by means of special signs.*

2.1 Important information

Always read the manual before using the valve!

WARNING

Indicates that special procedures must be followed to avoid serious personal injury.

CAUTION

Indicates that special procedures must be followed to avoid damage to the valve.

NOTE

Indicates important information to simplify or clarify procedures.

2.2 Warning signs

General warning:



Caustic agents:



All warnings in the manual are summarised on this page.

Pay special attention to the instructions below so that serious personal injury and/or damage to the valve are avoided.

2.3 Safety precautions

Installation:



Always read the technical data thoroughly (see chapter 7 Technical data)

Always release compressed air after use.

Never touch the moving parts if the actuator is supplied with compressed air.

Never touch the valve or the pipelines when processing hot liquids or when sterilising.

Never dismantle the valve with the valve and pipelines under pressure.

Never dismantle the valve when it is hot.

Operation:



Never dismantle the valve with the valve and pipelines under pressure.

Never dismantle the valve when it is hot.

Always read the technical data thoroughly (see chapter 7 Technical data)

Always release compressed air after use.

Never touch the valve or pipelines when processing hot liquids or when sterilising.

Never touch the moving parts if the actuator is supplied with compressed air.

Always rinse well with clean water after cleaning.



Always handle lye and acid with great care.

Maintenance:



Always read the technical data thoroughly (see chapter 7 Technical data)

Always release compressed air after use.

Never service the valve when it is hot.

Never service the valve with the valve and pipelines under pressure.

Never stick your fingers through the valve ports if the actuator is supplied with compressed air.

Never touch the moving parts if the actuator is supplied with compressed air.

Always use Alfa Laval genuine spare parts. The warranty of Alfa Laval products is dependent on the use of Alfa Laval genuine spare parts.

Transportation:

Always ensure that compressed air is released.

Always ensure that all connections are disconnected before attempting to remove the valve from the installation.

Always drain liquid out of valves before transportation.

Always use predesigned lifting points, if available.

Always ensure sufficient fixing of the valve during transportation - if specially designed packaging material is available, it must be used.

3 Installation

*The instruction manual is part of delivery. Study the instructions carefully.
The items refer to the Parts List and Service Kits section.*

3.1 Unpacking/delivery

Step 1

CAUTION

Alfa Laval cannot be held responsible for incorrect unpacking.

Check the delivery for:

1. Valve body
 2. Actuator
 3. Membrane
 4. Clamp ring (size 25 only)
 5. Plug (size 4 and 10 only)
-

Step 2

Remove any packing materials from the valve/valve parts.
Inspect the valve/valve parts for visible transport damages.
Avoid damaging the valve/valve parts.

3.2 General installation

Step 1



Always read the technical data thoroughly.
See chapter 7 Technical data



Always release compressed air after use.

CAUTION

Alfa Laval cannot be held responsible for incorrect installation.

Study the instructions carefully.

The valve is supplied as separate parts to facilitate welding.

The items refer to the Parts List and Service Kits section.

Check the valve for smooth operation after welding.

3.3 Valve body installation

Fitting of valve body

The valve body can be integrated into a tank, fitted on pipes or mounted with a clamp connection.

The valve must always be fitted so that the connections are placed vertically in relation to each other.

If the valve is fitted otherwise, it will not function appropriately.

Tank

When integrated into a tank, the valve is welded from the inside of the tank.

For a size 4 valve, a hole of $\text{Ø}29$ is made in the tank.

For a size 10 valve, a hole of $\text{Ø}38$ is made in the tank.

For a size 25 valve, a hole of $\text{Ø}70$ is made in the tank.

The connections are fitted so that they are placed vertically.

The body flushes with the inner side of the tank.

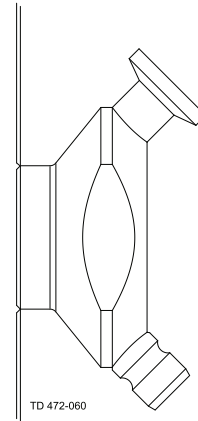

Pipes

Standard

The valve is delivered with a machined collar, which makes it possible to fit it onto a collar on a pipe.

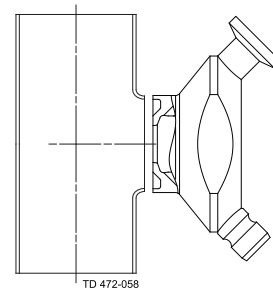

Clamp

The valve can also be mounted by using a clamp connection.

Size 4 & 10

Seal ring (EPDM)

25 mm (A): 9611-99-1358

38 mm (A): 9611-99-1359

Clamp ring: 211053

Size 25:

Seal ring (EPDM): 9611-99-1361

Clamp ring: 211055

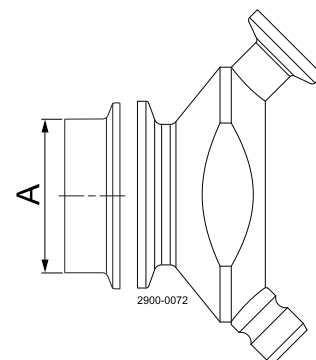

3 Installation

Study the instructions carefully.
The valve is supplied as separate parts to facilitate welding.
The items refer to the Parts List and Service Kits section.
Check the valve for smooth operation after welding.

3.4 Fitting of actuator – sizes 4 and 10

Step 1

Fit the membrane on the actuator.

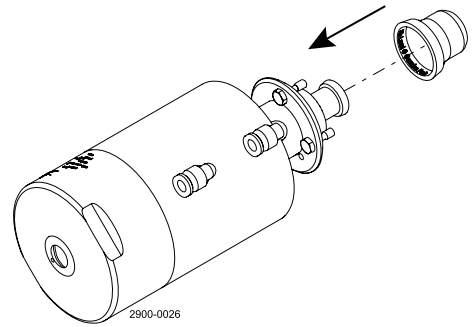

Step 2

Fit the actuator on the valve body.



Make sure that the two $\varnothing 3.2$ mm leak detection holes are facing downwards.

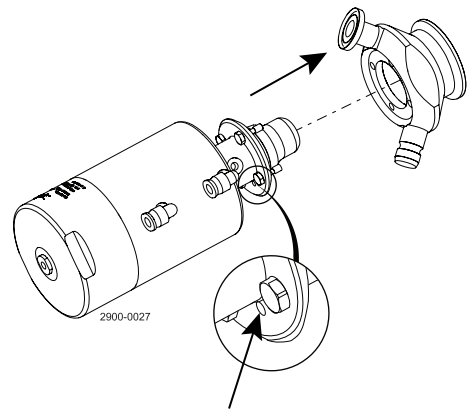

Step 3

Tighten screw with a torque of 2-3 Nm.

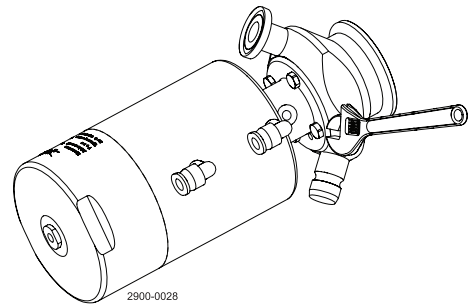

Study the instructions carefully.
The valve is supplied as separate parts to facilitate welding.
The items refer to the Parts List and Service Kits section.
Check the valve for smooth operation after welding.

Step 4

Fit the air hose on the actuator.

Double seat actuator

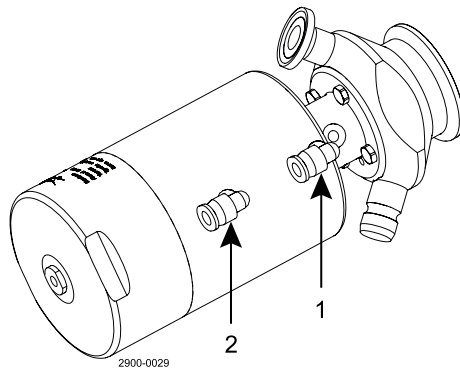

Single seat actuator

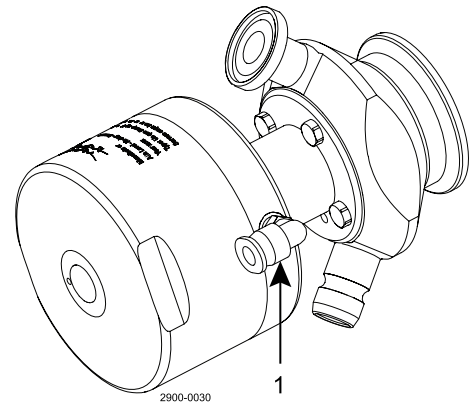

1. Sample/open connection
2. Steam/cleaning connection

3 Installation

Study the instructions carefully.

The valve is supplied as separate parts to facilitate welding.

The items refer to the parts list and service kit section.

Check the valve for smooth operation after welding.

3.5 Fitting of actuator – size 25

Step 1

Fit the membrane on the actuator.

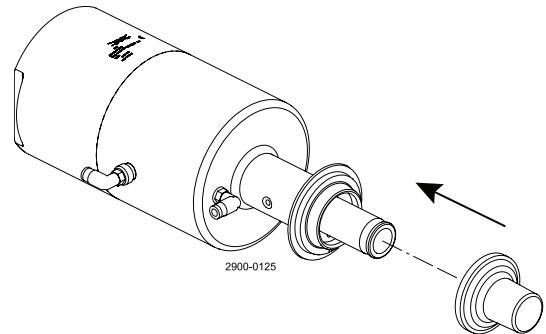

Step 2

Apply air to the open connection

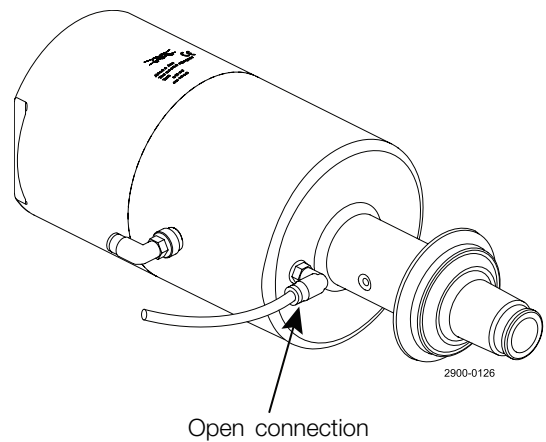

Step 3



Make sure that the two Ø3.2 mm leak detection holes are facing downwards

Mount the actuator to the valve body while air is applied to the open connection

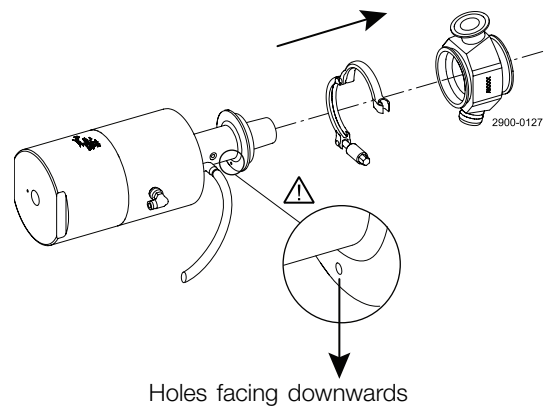

Step 4

Tighten the clamp ring with a torque of 12 Nm.

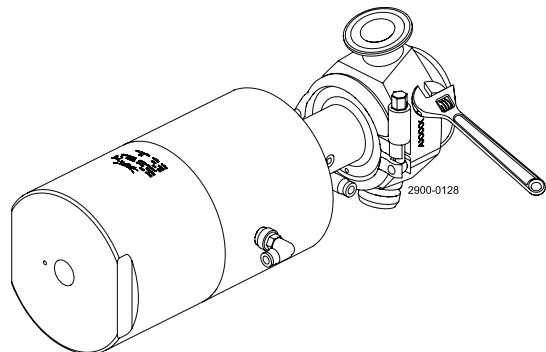

Study the instructions carefully.
 The valve is supplied as separate parts to facilitate welding.
 The items refer to the parts list and service kit section.
 Check the valve for smooth operation after welding.

3.6 Adjustment of valve

The valve is fully adjustable in its movement, which enables a precise sample every time.

Step 1

Remove the top plug.

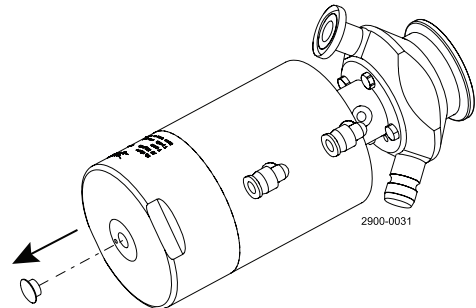

Step 2

Use a hexagon socket spanner to adjust the movement of the actuator. The actuator has by default a movement of:

Size 4	4 mm
Size 10	10 mm
Size 25	25 mm

Turn the spanner anticlockwise to decrease the movement of the actuator.
 Control the adjusted movement by applying air to the sample air connection (A1).

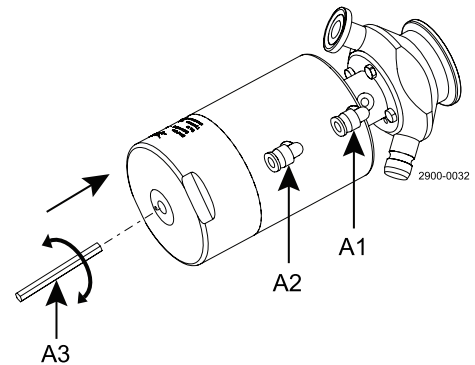

A1	Sample/open connection
A2	Steam/clean connection
A3	Hexagon socket spanner (Sizes 4 and 10 = 5 mm, size 25 = 10 mm)

Step 3

Mount the top plug.

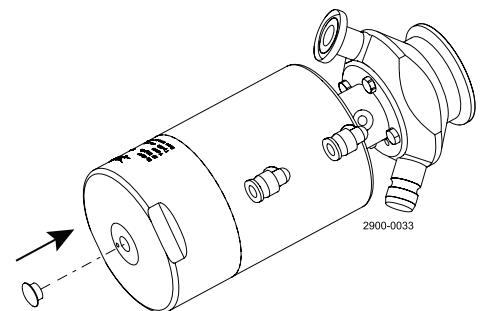

3 Installation

Study the instructions carefully.

The valve is supplied as separate parts to facilitate welding.

The items refer to the parts list and service kit section.

Check the valve for smooth operation after welding.

3.7 Installation of proximity switch (accessories)

The Unique Sampling Valve can be fitted with a proximity switch to indicate whether it is in the closed, open or cleaning position.

Single Seat:

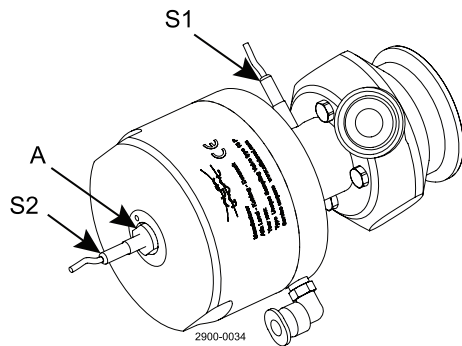

Double Seat:

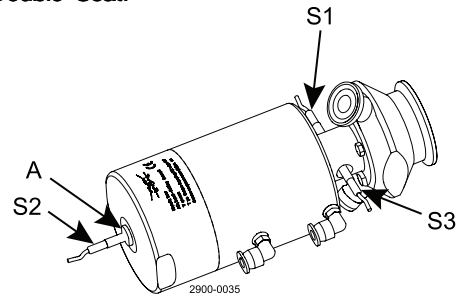

- S1 Proximity switch for closed valve
- S2 Proximity switch for open valve
- S3 Proximity switch for valve in cleaning position
- A Adaptor for proximity switch
 - Sizes 4 and 10: 9614-0174-01
 - Size 25: 9614-2579-01

3.8 Recycling information

• Unpacking

- Packing material consists of wood, plastics, cardboard boxes and, in some cases, metal straps.
- Wood and cardboard boxes can be reused, recycled or used for energy recovery.
- Plastics should be recycled or burnt at an authorised waste incineration plant.
- Metal straps should be sent for material recycling.

• Maintenance

- During maintenance, oil and worn parts in the machine are replaced.
- All metal parts should be sent for material recycling.
- Worn out or defective electronic parts should be sent to a licensed handler for material recycling.
- Oil and all non-metal worn parts must be handled in accordance with local regulations.

• Scrapping

- At the end of use, the equipment should be recycled according to relevant, local regulations. As well as the equipment itself, any hazardous residues from the process liquid must be considered and dealt with in a proper manner. When in doubt, or in the absence of local regulations, please contact your local Alfa Laval sales company.
-

4 Operation – Single Seat Valve

*Study the instructions carefully and pay special attention to the warnings!
Ensure that the valve operates smoothly.
The items refer to the Parts List and Service Kits section.*

4.1 Operation

Step 1



Always read the technical data thoroughly.
See chapter 7 Technical data



Always release compressed air after use.

CAUTION

Alfa Laval cannot be held responsible for incorrect operation.

Step 2



Never touch the valve or the pipelines when processing hot liquids or when sterilising.

Burning danger!

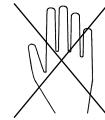

Step 3



Never touch the moving parts if the actuator is supplied with compressed air.

Moving parts!



4 Operation – Single Seat Valve

Study the instructions carefully.

The items refer to the Parts List and Service Kits section.

Handle scrap correctly.

4.2 Sterilisation – single seat pneumatic actuator

Step 1



Always sterilise the valve before taking a sample

Sterilisation procedure:

1. Make sure that the valve is in the closed position before sterilisation (no air is applied to air connection A1). If using proximity switches, S1 will become active.
2. Connect steam to the upper connection. It is advisable to use the Non-return valve (N) on the upper connection. This enables steaming and sampling without removing the steam line or using an unsterile blind cap.
3. Steam the valve for a period of 2 minutes, at a constant pressure of 2 bar. A pressure relief valve (P) is required. If using a pressure relief valve, release the steam by pulling the handle (P1) before removing the pressure relief valve (P) from the sampling valve.
4. The valve is now ready for taking a representative and sterile sample.

A1 = Air connection for open valve

A = Adaptor for proximity switch*
- sizes 4 and 10: 9614-0174-01
- size 25: 9614-0174-02

S1 = Proximity switch for closed valve*

S2 = Proximity switch for open valve*

N = Non-return valve*

G = Seal ring*
- sizes 4 and 10: 290273
- size 25: 9611-99-2012

C = Clamp ring*
- sizes 4 and 10: 211290
- size 25: 211053

P = Pressure relief valve*
- sizes 4 and 10: 9614-1957-01
- size 25 9614-1957-02

P1 = Handle for quick release of steam

P2 = Steam outlet - be careful!

* = accessories

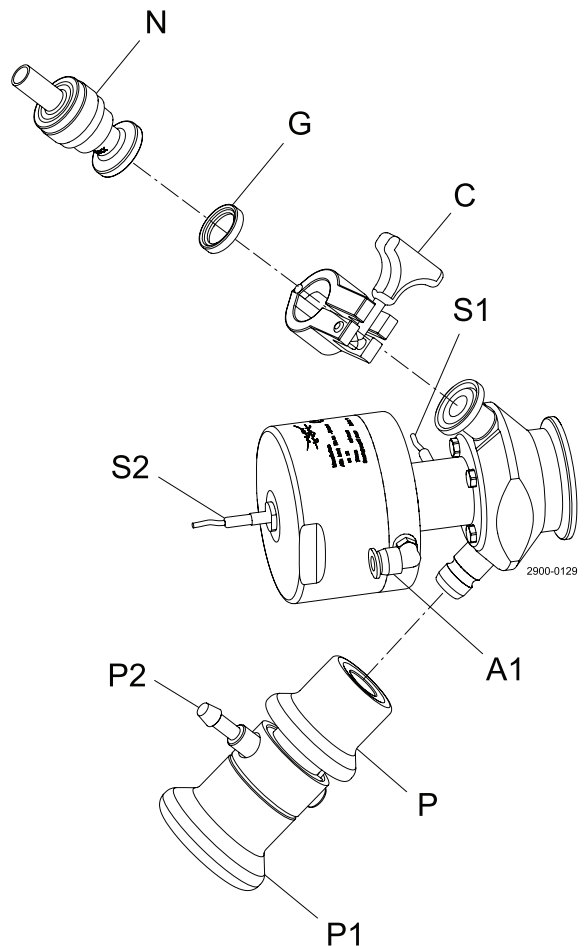

4 Operation – Single Seat Valve

Pay attention for possible faults. Study the instructions carefully.
The items refer to the Parts List and Service Kits section.

4.3 Sampling – single seat pneumatic actuator

Step 1

Taking a sample

1. Open the valve by supplying air to the A1 connection until the desired product flow is obtained.
2. Once the required amount of sample has been taken, shut off the supplied air.

NOTE

If the actuator is fitted with proximity switches, S1 is active when the valve is closed and S2 is active when the valve is open.

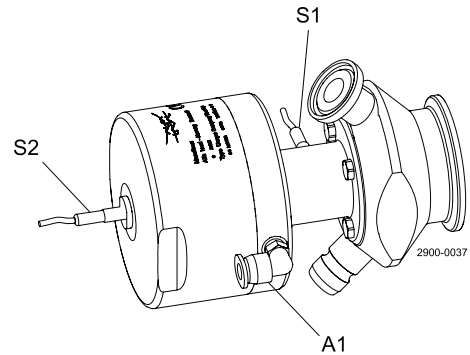

- A1 Air to open valve
- S1 Proximity switch to register that valve is open (accessories)
- S2 Proximity switch to register that valve is closed (accessories)

Step 2

Important!



Always sterilise the valve after taking a sample.

1. Once the sampling has taken place, it is very important that the valve is properly cleaned and sterilised, so as to avoid the sample remaining and being enclosed for shorter or longer periods at the time.
2. Therefore repeat the sterilisation procedure, (see section 4.2), each time the valve has been in use.

4.4 Troubleshooting

NOTE!

Study the maintenance instructions carefully before replacing worn parts.

Problem	Cause/r esult	Repair
External product leakage	Worn membrane	Replace the membrane
	Product pressure exceeds valve specification	Reduce the product pressure
The valve does not open/close	Product pressure exceeds actuator specification	Reduce product pressure
	Supplied air pressure is too low	Min. air pressure is 5 bar

4 Operation – Single Seat Valve

Study the instructions carefully and pay special attention to the warnings!

4.5 Recommended cleaning

Step 1



Always handle lye and acid with great care.

Caustic danger!



Always use rubber gloves!



Always use protective goggles!

Step 2



Never touch the valve or the pipelines when sterilising.

Burning danger!

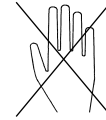

Step 3

Clean the plug and the seats correctly.

Pay special attention to the warnings!

Lift and lower valve plug momentarily!

Step 4

Examples of cleaning agents:

Use clean water, free from chlorides.

1. 1% by weight NaOH at 70° C

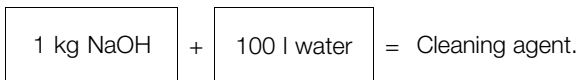

2. 0.5% by weight HNO₃ at 70° C

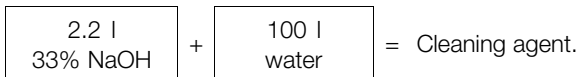
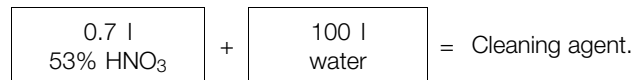

Step 5

1. Avoid excessive concentration of the cleaning agent.
2. Adjust the cleaning flow to the process.
3. **Always** rinse well with clean water after cleaning.

Always rinse!

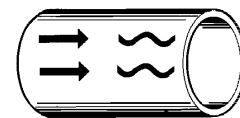

Clean water Cleaning agents

NOTE

The cleaning agents must be stored/disposed of in accordance with current regulations/directives.

5 Operation – Double Seat Valve

*Study the instructions carefully and pay special attention to the warnings!
Ensure that the valve operates smoothly.
The items refer to the Parts List and Service Kits section.*

5.1 Operation

Step 1



Always read the technical data thoroughly.
See chapter 7.

CAUTION

Alfa Laval cannot be held responsible for incorrect operation.



Always release compressed air after use.

Step 2



Never touch the valve or the pipelines when processing hot liquids or when sterilising.

Burning danger!

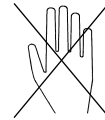

Step 3



Never touch the moving parts if the actuator is supplied with compressed air.

Moving parts!

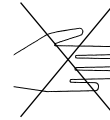

5 Operation – Double Seat Valve

Study the instructions carefully.

The items refer to the Parts List and Service Kits section.

Handle scrap correctly.

5.2 Sterilisation – double seat pneumatic actuator

Step 1



Always sterilise the valve before taking a sample

Sterilisation procedure:

1. Make sure that the valve is in closed position before sterilisation. (No air is applied to air connection A1) - If using proximity switches, S1 will become active.
2. Apply air to A2 in order to actuate the valve in cleaning position - inner seat is now sealed (if proximity switches are used, S3 will become active).
3. Connect steam to the upper connection. It is advisable to use the Non-return valve (N) (accessories) on the upper connection. This enables steaming and sampling without removing the steam line or using an unsterile blind cap
4. Steam the valve for a period of 2 minutes, at a constant pressure of 2 bar. A pressure relief valve (P) (accessories) is required. If using a pressure relief valve (P), release the steam by pulling the handle (P2) before removing the pressure relief valve from the sampling valve.
5. Shut off the air supply to air connection A2.
6. The valve is ready for taking a representative and sterile sample.

A1 = Air connection for open valve

A2 = Air connection for cleaning position

A = Adaptor for proximity switch*
- sizes 4 and 10: 9614-0174-01
- size 25: 9614-0174-02

S1 = Proximity switch for closed valve*

S2 = Proximity switch for open valve*

S3 = Proximity switch for cleaning position*

N = Non-return valve*

G = Seal ring*
- sizes 4 and 10: 290273
- size 25: 9611-99-2012

C = Clamp ring*
- size 4 and 10: 211290
- size 25: 211053

P = Pressure relief valve*
- sizes 4 and 10: 9614-1957-01
- size 25: 9614-1957-02

P1 = Handle for quick release of steam

P2 = Steam outlet - be careful!

* = accessories

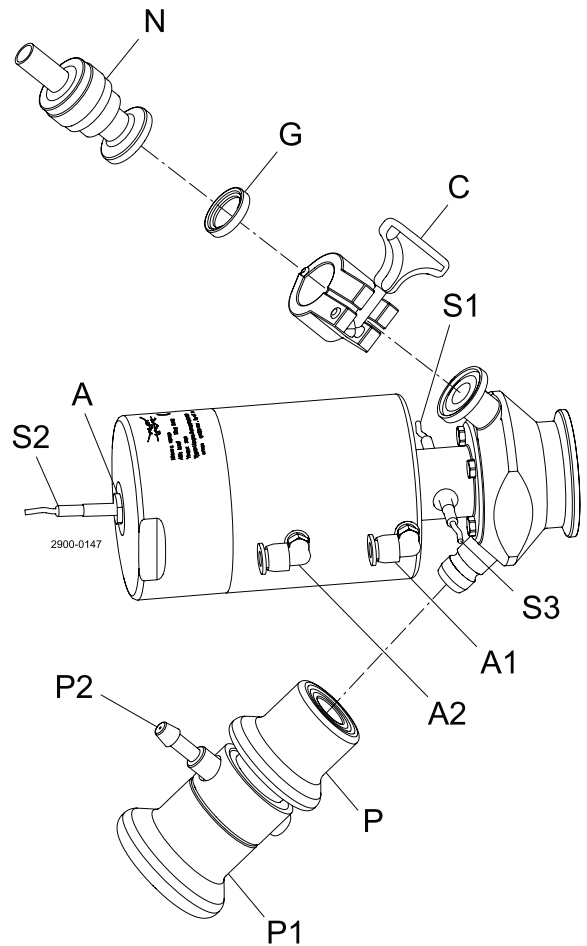

5 Operation – Double Seat Valve

Pay attention to possible faults. Study the instructions carefully.
The items refer to the Parts List and Service Kits section.

5.3 Sampling – double seat pneumatic actuator

Step 1

Taking a sample

1. Apply air to A1 until the desired product flow is obtained. (If proximity switches are used, S2 will become active.)
2. Once the required amount of sample has been taken, close the valve by removing the air from A1. (If proximity switches are used, S1 will become active.)

- A1 Air connection for open valve
S1 Proximity switch for closed valve (If mounted)
S2 Proximity switch for open valve (If mounted)

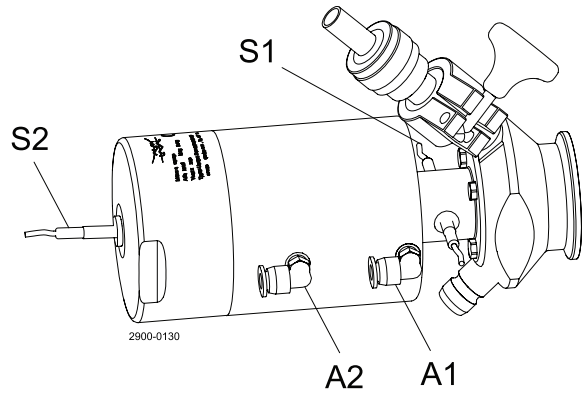

Step 2

Important!



Always sterilise the valve after taking a sample.

1. Once sampling has taken place, it is very important that the valve is properly cleaned and sterilised, so as to avoid the sample remaining and being enclosed for shorter or longer periods at the time.
2. Therefore repeat the sterilisation procedure (see section 5.2) each time the valve has been in use.

5.4 Troubleshooting

NOTE!

Study the maintenance instructions carefully before replacing worn parts.

Problem	Cause	Repair
External product leakage	Worn membrane	Replace the membrane
	Product pressure exceeds valve specification	Reduce the product pressure
The valve does not open/close	Product pressure exceeds actuator specification	Reduce product pressure
	Supplied air pressure is too low	Min. air pressure is 5 bar

5 Operation – Double Seat Valve

Study the instructions carefully and pay special attention to the warnings!

5.5 Recommended cleaning

Step 1



Always handle lye and acid with great care.

Caustic danger!



Always use rubber gloves!



Always use protective goggles!

Step 2



Never touch the valve or the pipelines when sterilising.

Burning danger!

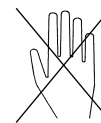

Step 3

Clean the plug and the seats correctly.

Pay special attention to the warnings!

Lift and lower valve plug momentarily!

Step 4

Examples of cleaning agents:

Use clean water, free from chlorides.

1. 1% by weight NaOH at 70° C

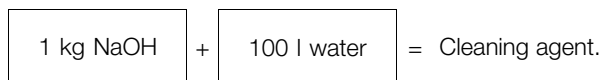

2. 0.5% by weight HNO₃ at 70° C

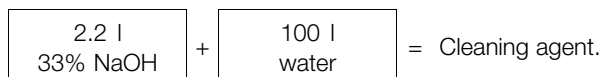
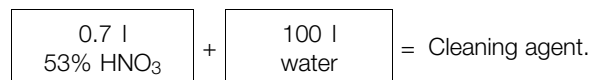

Step 5

1. Avoid excessive concentration of the cleaning agent.
2. Adjust the cleaning flow to the process.
3. **Always** rinse well with clean water after the cleaning.

Always rinse!

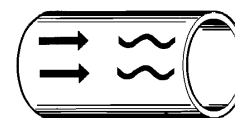

Clean water Cleaning agents

NOTE

The cleaning agents must be stored/disposed of in accordance with current regulations/directives.

Maintain the valve regularly. Study the instructions carefully and pay special attention to the warnings!
Always use Alfa Laval genuine spare parts and keep spare rubber seals and lip seals in stock. The warranty of Alfa Laval products is dependent on the use of Alfa Laval genuine spare parts. Check the valve for smooth operation after service.

6.1 General maintenance

Step 1



Always read the technical data thoroughly.
See chapter



Always release compressed air after use.

NOTE

All scrap must be stored/disposed of in accordance with current regulations/directives.

Step 2



Never service the valve when it is hot.



Never service the valve with the valve and pipelines under pressure.

Atmospheric pressure required!

Burning danger!

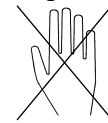

Step 3



Never stick your fingers through the valve ports if the actuator is supplied with compressed air.

Cutting danger!



Step 4



Never touch the moving parts if the actuator is supplied with compressed air.

Moving parts!

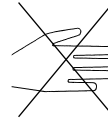

6 Maintenance

Maintain the valve regularly. Study the instructions carefully and pay special attention to the warnings!
Always use Alfa Laval genuine spare parts and keep spare rubber seals and lip seals in stock. The warranty of Alfa Laval products is dependent on the use of Alfa Laval genuine spare parts. Check the valve for smooth operation after service.

Below are some guidelines for maintenance and lubrication intervals. Please note that the guidelines are for normal working conditions in one shift.

	Membrane	Actuator
Preventive maintenance	Replace after 500-1000 samples (depending on working conditions).	Disassemble, clean and lubricate the actuator every 5 years (depending on working conditions).
Maintenance after leakage (leakage normally starts slowly)	Replace at the end of the day.	Disassemble, clean and lubricate the actuator when possible.
Planned maintenance	<ul style="list-style-type: none"> - Regular inspection for leakage and smooth operation - Keep a record of the valve - Use the statistics for inspection planning Replace after leakage	<ul style="list-style-type: none"> - Regular inspection for leakage and smooth operation - Keep a record of the actuator - Use the statistics for inspection planning
Lubrication	None	Before fitting Klüber Paraliq GTE 703 or similar

Pre-use check:

1. Supply compressed air to the actuator.
2. Open and close the valve several times to ensure that it operates smoothly.

Pay special attention to the warnings!

Recommended spare parts and service kits (see Section 9)

Warning!

Make sure that there never is a gap between the actuator top and actuator body when the valve is in use.

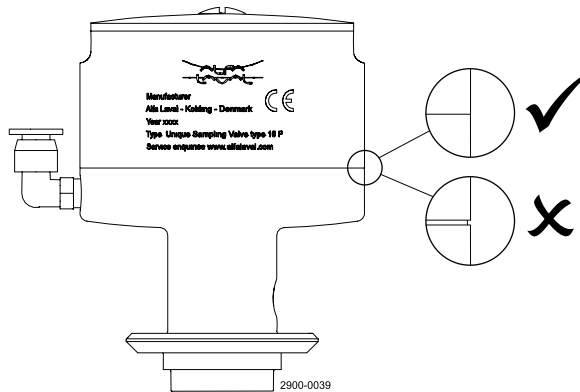

Study the instructions carefully. The items refer to the Parts List and Service Kits section. Handle scrap correctly.

NC = Normally closed.

NO = Normally open.

A/A = Air/air activated.

6.2 Dismantling of valve

Step 1

1. Undo screws/clamp ring

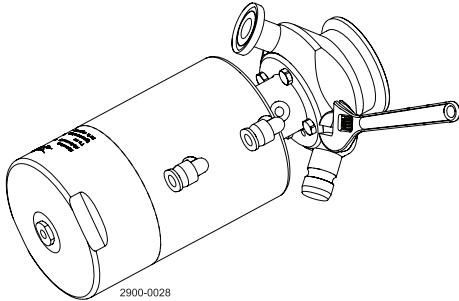

Sizes 4 and 10

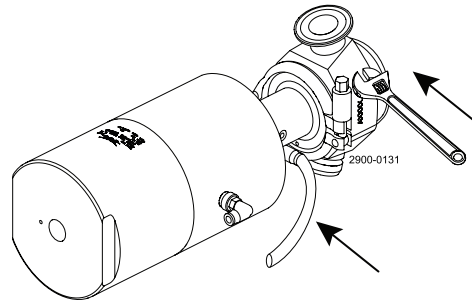

Size 25

Apply compressed air to the open connection before removing the clamp.

Step 2

1. Pull actuator from valve body.
2. Remove membrane.

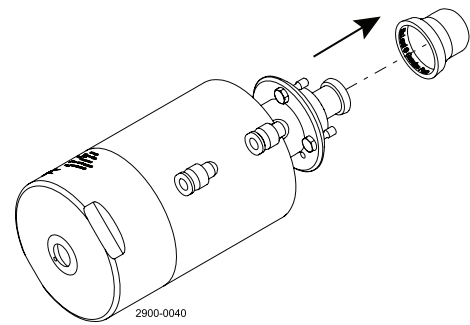

6.3 Valve assembly

Reverse order of section 6.2 Dismantling of valve.

6 Maintenance

Study the instructions carefully.

The items refer to the Parts List and Service Kits section.

Handle scrap correctly.

6.4 Dismantling of single seat actuator

If the actuator has to be dismantled due to membrane leakage or maintenance, follow the instruction described below.

Note: The actuator can be dismantled using regular tools.

Step 1

Remove top.

Spanner size:

- Size 4: 47 mm (9611-98-0111)

- Size 10: 66 mm (9611-98-0141)

- Size 25: 108 mm (9611-98-0115)

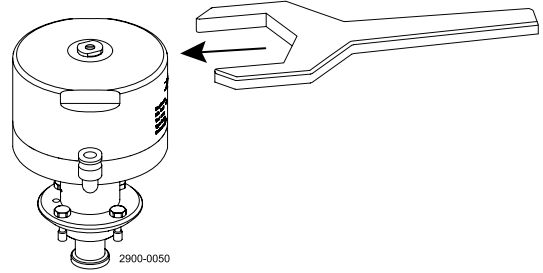

Step 2

Remove springs.

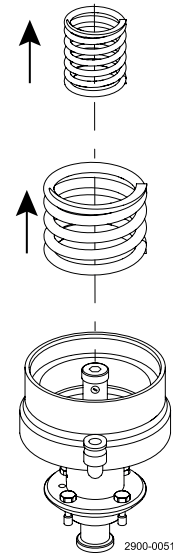

Step 3

Pull out piston.

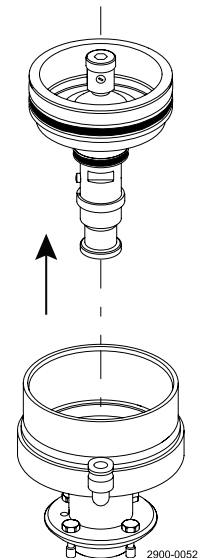

Study the instructions carefully.
The items refer to the Parts List and Service Kits section.
Handle scrap correctly.

6.5 Assembly of single seat actuator

Step 1

Assemble the actuator in reversed order of dismantling - section 6.4.
Don't forget to lubricate the actuator during assembly - see section 6.1.

Tighten top to the following torque:

- Size 4: **20 Nm**
- Size 10: **30 Nm**
- Size 25: **50 Nm**

Warning!

Make sure that there is no gap between the actuator top and actuator body when the actuator is reassembled.

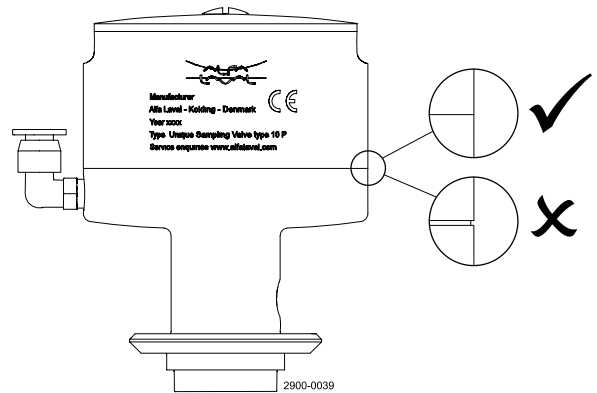

Step 2

After the actuator has been assembled, it is important to measure the piston position to ensure correct function of the valve.

Sizes 4 and 10

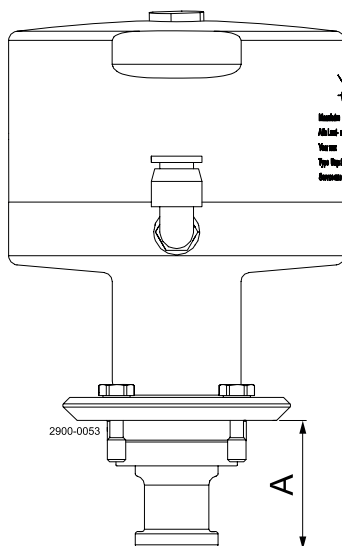

Size 25

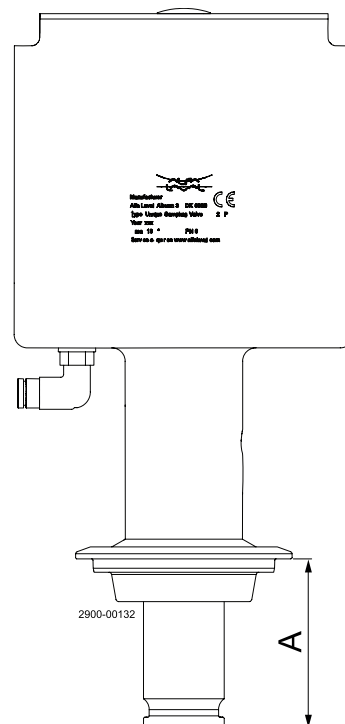

- A:
- Size 4: 19.1 - 19.3 mm
 - Size 10: 28 - 28.2 mm
 - Size 25: 63.05 - 63.25 mm

6 Maintenance

Study the instructions carefully.

The items refer to the Parts List and Service Kits section.

Handle scrap correctly.

6.6 Dismantling of double seat actuator

If the actuator has to be dismantled due to membrane leakage or maintenance, follow the instruction described below.

Note:

The actuator can be dismantled by using regular and some special tools.

Step 1

Remove top.

Spanner size:

- Size 4: 47 mm (9611-98-0111)
- Size 10: 66 mm (9611-98-0141)
- Size 25: 108 mm (9611-98-0115)

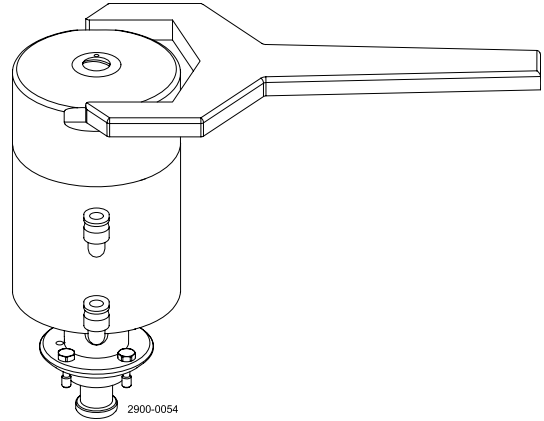

Step 2

Remove springs.

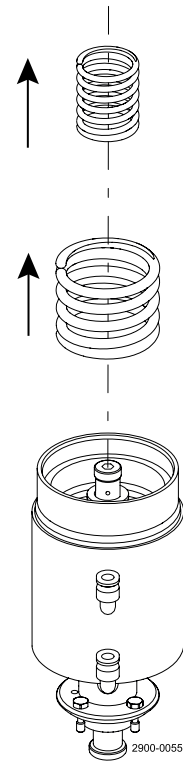

*Study the instructions carefully.
The items refer to the Parts List and Service Kits section.
Handle scrap correctly.*

Step 3

Pull up piston assembly.

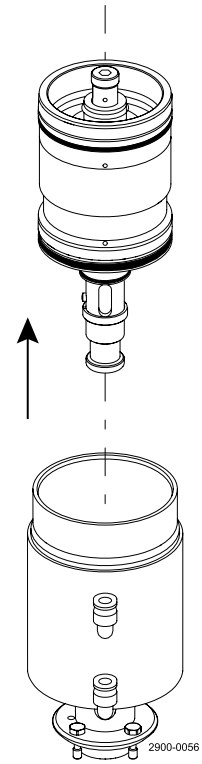

Step 4

Unscrew top nut.

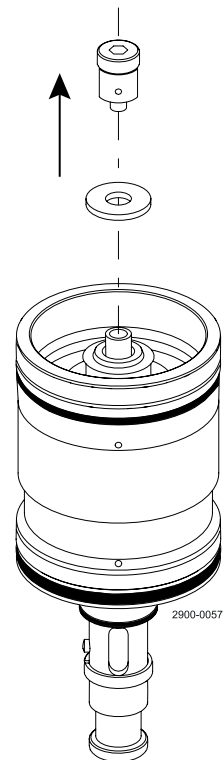

6 Maintenance

*Study the instructions carefully.
The items refer to the Parts List and Service Kits section.
Handle scrap correctly.*

Step 5

Remove inner stem and pin from piston assembly.

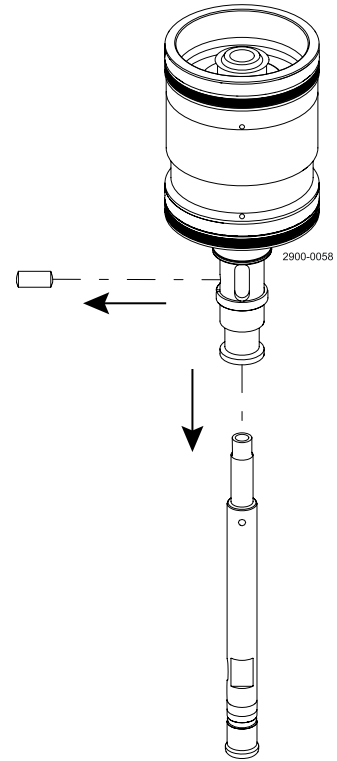

Step 6

Fit the hold tool in a vice. Fit the piston assembly into the hold tool.

Size 4: 9614-0239-01
Size 10: 9614-0239-02
Size 25: 9614-0239-03

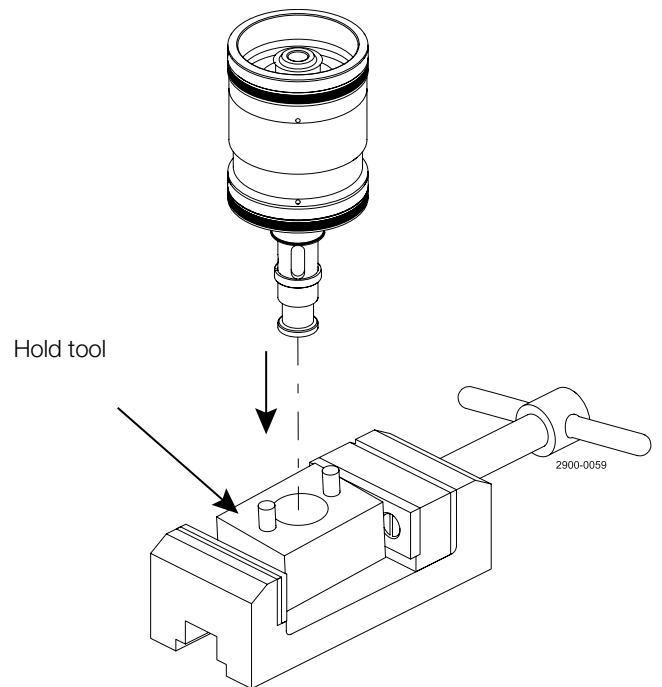

*Study the instructions carefully.
The items refer to the Parts List and Service Kits section.
Handle scrap correctly.*

Step 7

Unscrew the top piston with a socket spanner.

- A. Socket spanner
- B. Piston assembly
- C. Hold tool

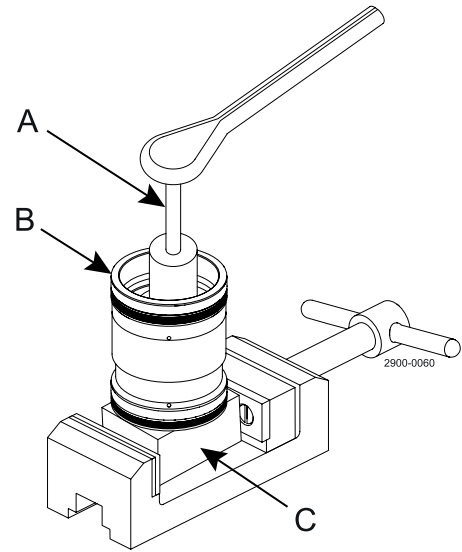

Step 8

Remove top piston, inner piston, spring disc and springs.

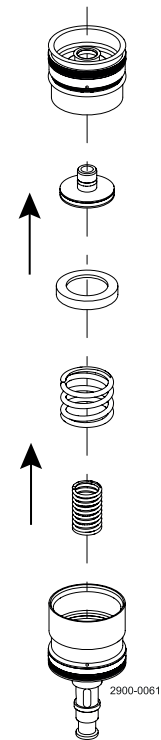

6 Maintenance

*Study the instructions carefully.
The items refer to the Parts List and Service Kits section.
Handle scrap correctly.*

Step 9

Remove outer stem.

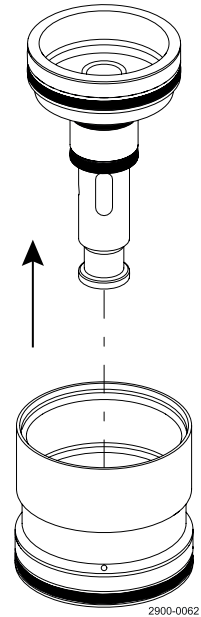

*Study the instructions carefully.
The items refer to the Parts List and Service Kits section.
Handle scrap correctly.*

6.7 Assembly of double seat actuator

Step 1

Mount the tool ring on the outer stem.

Note:

Don't forget to lubricate the actuator during assembly - see chapter 6.1 General maintenance.

Mount tool

Size 4: 9614-0258-01

Size 10: 9614-0258-02

Size 25: 9614-0258-03

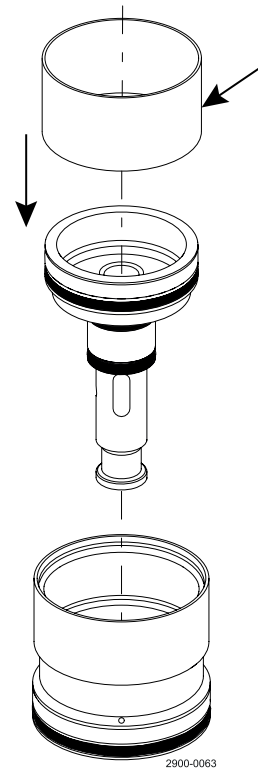

Step 2

Mount springs, spring disc, inner piston and top piston in the bottom piston.

Note:

Don't forget to lubricate the thread.

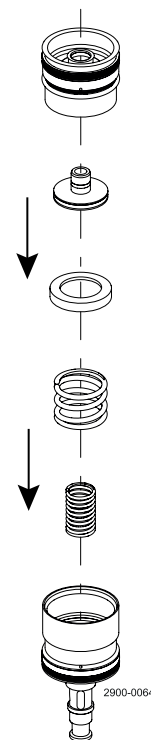

6 Maintenance

Study the instructions carefully.

The items refer to the Parts List and Service Kits section.

Handle scrap correctly.

Step 3

Tighten top to the following torque:

- Size 4: **20Nm**
- Size 10: **30Nm**
- Size 25: **50Nm**

Warning!

Make sure that there is no gap between the piston top and piston bottom when reassembled.

- A. Socket spanner
- B. Piston assembly
- C. Hold tool

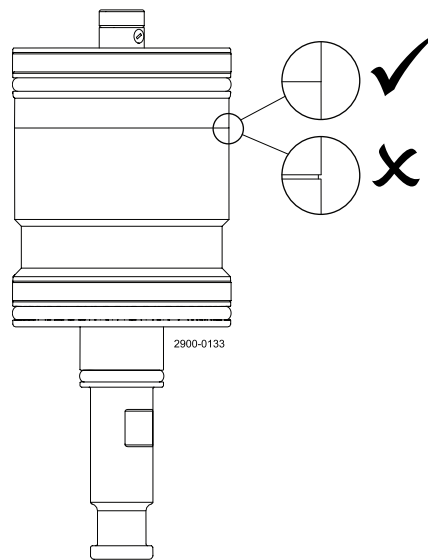
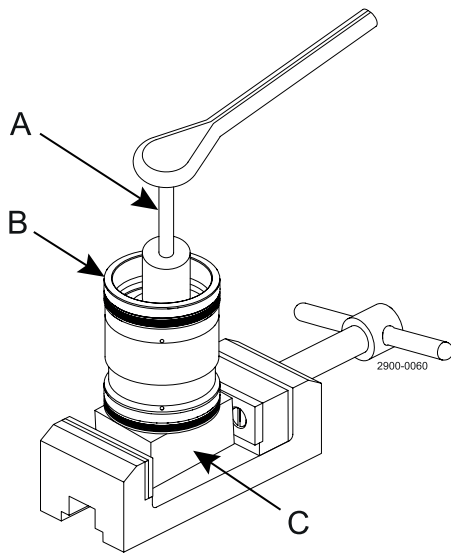

Step 4

Mount inner stem and pin in piston assembly.

Note:

Make sure that the inner stem is orientated correctly.

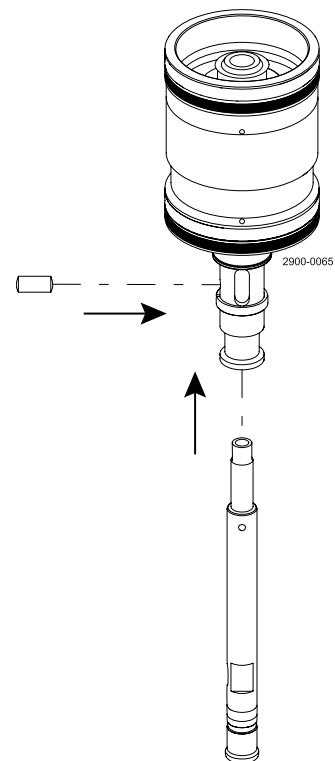

*Study the instructions carefully.
The items refer to the Parts List and Service Kits section.
Handle scrap correctly.*

Step 5

Mount top screw on inner stem.

Note:

Use Loctite 243 to secure nut.

Tighten nut to the following torque:

- Sizes 4 and 10: **3 Nm**
- Size 25: **5 Nm**

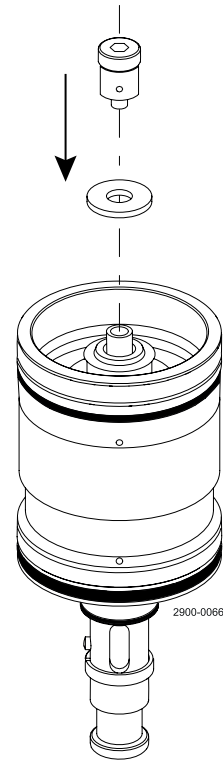

Step 6

Mount piston assembly, spring and actuator top.

Note:

Tighten top to the following torque:

- Size 4: **20 Nm**
- Size 10: **30 Nm**
- Size 25: **50 Nm**

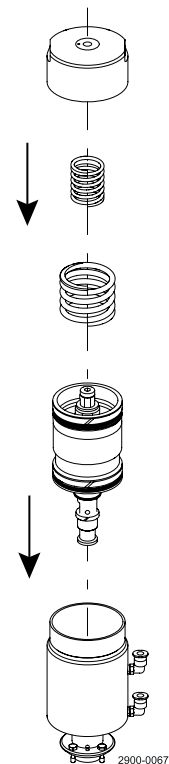

6 Maintenance

Study the instructions carefully.
The items refer to the Parts List and Service Kits section.
Handle scrap correctly.

Warning!

Make sure that there is no gap between the actuator top and actuator body when the actuator is reassembled.

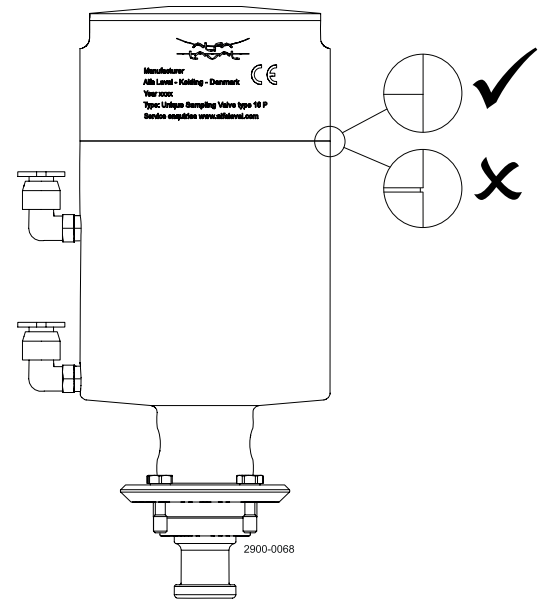

Step 7

After the actuator has been assembled, it is important to measure the piston in both closed and seat lift position to ensure correct function of the valve. After assembly, check that the actuator is operating smoothly.

Sizes 4 and 10

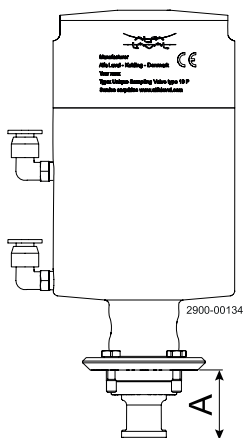

Size 25

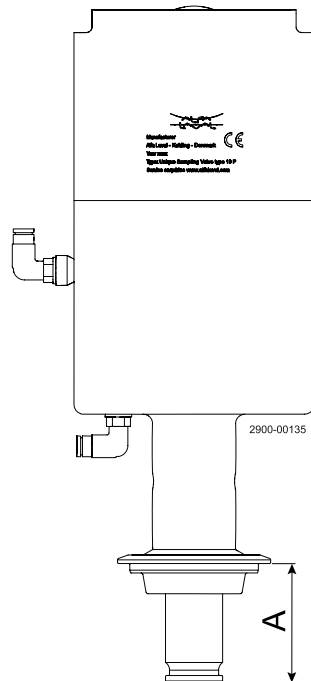

Sizes 4 and 10

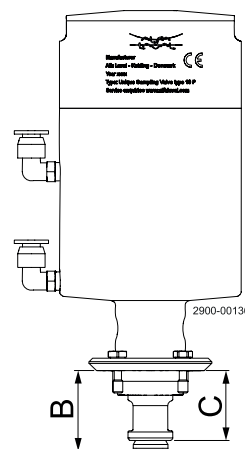

Size 25

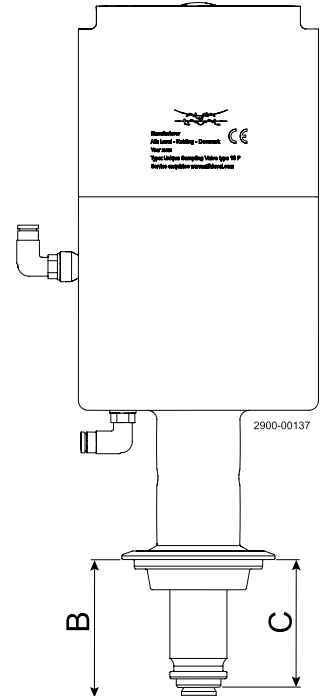

A:
Size 4: 19.1 - 19.3 mm
Size 10: 28.0 - 28.2 mm
Size 25: 63.05 - 63.24 mm

B:
Size 4: 21.0 - 21.2 mm
Size 10: 28.3 - 30.15 mm
Size 25: 66.85 - 67.15 mm

C:
Size 4: 17.4 - 17.6 mm
Size 10: 26.0 - 26.2 mm
Size 25: 58.25-58.45 mm

*It is important to observe the technical data during installation, operation and maintenance.
Inform all personnel about the technical data.*

7.1 Technical data

The patented double seat ensures representative sampling as the seat area is accessible for sterilisation.

The inner spindle pushes the membrane seal down onto the inner seat, closing off the product.

Once the inner spindle is in place, the outer spindle is retracted, moving the membrane seal away from the outer seat making it possible to remove any remaining product and sterilise the outer seat.

Data - valve/actuator	
Max. product pressure	600 kPa (6 bar).
Max. working temperature	121 °C
Max. air supplied	10 bar
Weight:	
- Size 4 Double Seat	1.5 kg
- Size 10 Single Seat	1.9 kg
- Size 10 Double Seat	3.3 kg
- Size 25 Single Seat	8.2 kg
- Size 25 Double Seat	13.5 kg
Materials - valve/actuator	
Product wetted steel parts	1.4404 (316L) (internal Ra < 0.8 µm)
Membrane seal	EPDM
Optional product wetted seals	Q

7 Technical data

It is important to observe the technical data during installation, operation and maintenance.
Inform all personnel about the technical data.

Weight (kg)

Valve Size	Size 4															
Valve Head	Handle Double Seat								Pneumatic Double seat							
Valve Body Nominal size	Tank	Tri-clamp	Collarded pipe						Tank	Tri-clamp	Collarded pipe					
			ISO 25	ISO 38	ISO 51	ISO 25	DIN 40	DIN 50			ISO 25	ISO 38	ISO 51	DIN 25	DIN 40	DIN 50
Weight (kg)	0.7	0.7	0.7	0.7	0.7	0.7	0.7	0.7	0.7	1.7	1.7	1.7	1.7	1.7	1.7	1.7

Valve Size	Size 10															
Valve Head	Handle Double Seat								Pneumatic Double seat							
Valve Body Nominal size	Tank	Tri-clamp	Collarded pipe						Tank	Tri-clamp	Collarded pipe					
			ISO 25	ISO 38	ISO 51	ISO 25	DIN 40	DIN 50			ISO 25	ISO 38	ISO 51	DIN 25	DIN 40	DIN 50
Weight (kg)	1.1	1.1	1.1	1.1	1.1	1.1	1.1	1.1	1.1	3.3	3.3	3.3	3.3	3.3	3.3	3.3

Valve Size	Size 25					
Valve Head	Pneumatic Double seat					
Valve Body Nominal size	Tank	Tri-clamp	Collarded pipe			
			ISO 51	ISO 63.5	DIN 50	DIN 65
Weight (kg)	13.5	13.5	13.5	13.5	13.5	13.5

Noise

At a distance of 1 metre away from and 1.6 metres above the exhaust, the noise level of a valve actuator will be approximately 77 db (A) without a noise damper and approximately 72 db (A) with a damper. (Measured at 7 bar air-pressure.)

8 Parts List and Service Kits

Always use Alfa Laval genuine spare parts.

The warranty of Alfa Laval products is dependent on the use of Alfa Laval genuine spare parts.

8.1 Actuator for USV size 4 double seat

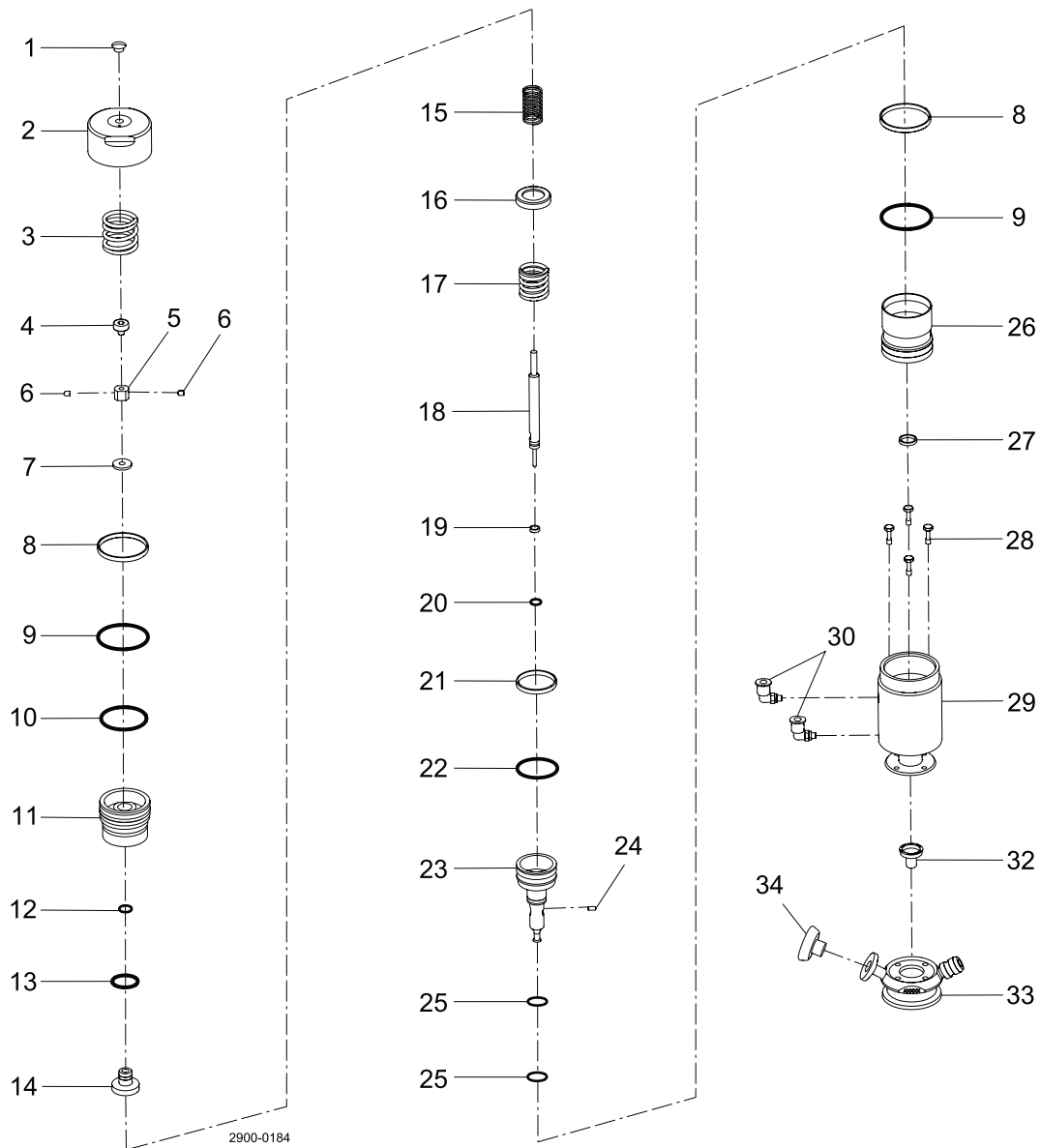

8 Parts List and Service Kits

Always use Alfa Laval genuine spare parts.

The warranty of Alfa Laval products is dependent on the use of Alfa Laval genuine spare parts.

Parts list

Pos.	Qty	Denomination
1	1	Actuator
2	1	Top plug
3	1	Actuator top
4	1	Spring
5	1	Adjuster screw
6	1	Adjuster nut
6 ▲	2	Set screw
7	1	Disc
8	2	Guide ring
9 ▲	2	O-ring
10 ▲	1	O-ring
11	1	Main piston top
12 ▲	1	O-ring
13 ▲	1	O-ring
14	1	Inner seat lift piston
15	1	Spring
16	1	Spring disc
17	1	Spring
18	1	Inner stem
19	1	Guide ring
20 ▲	1	O-ring
21	1	Guide ring
22 ▲	1	O-ring
23	1	Outer seat lift piston
24 ▲	1	Pin
25 ▲	2	O-ring
26	1	Main piston bottom
27	1	Guide ring
28	4	Mount screws
29	1	Actuator body
30	2	Air fitting angle
32	10	Membrane seal
33	1	Valve body
34	1	Plug for upper connection

Service kits

Denomination

Size 4

Service kit

▲ Service kit 9611924303

900-682/2

8 Parts List and Service Kits

Always use Alfa Laval genuine spare parts.

The warranty of Alfa Laval products is dependent on the use of Alfa Laval genuine spare parts.

8.2 Actuator for USV size 4 single seat

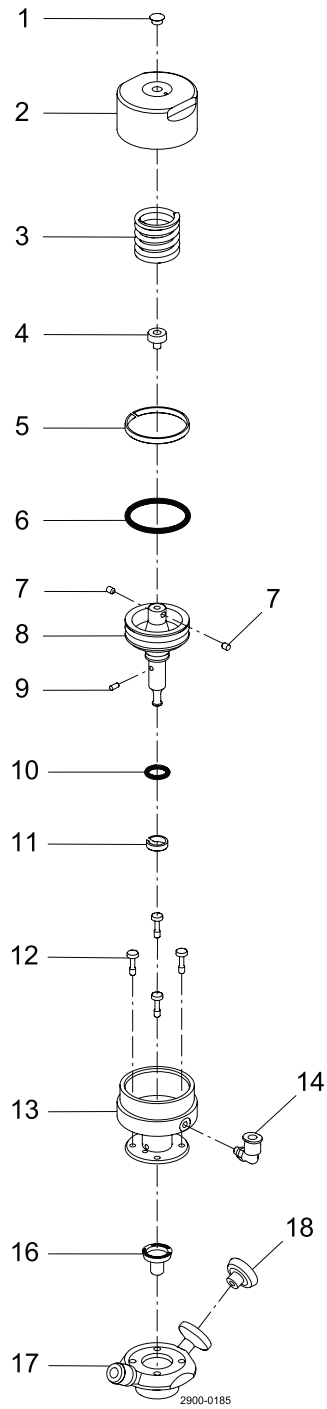

8 Parts List and Service Kits

Always use Alfa Laval genuine spare parts.

The warranty of Alfa Laval products is dependent on the use of Alfa Laval genuine spare parts.

Parts list

Pos.	Qty	Denomination
1	1	Actuator Top plug
2	1	Actuator top
3	1	Spring
4	1	Adjuster screw
5	1	Guide ring
6 ▲	1	O-ring
7 ▲	2	Set screw
8	1	Main piston
9 ▲	1	Pin
10 ▲	1	O-ring
11	1	Guide ring
12	4	Mount screws
13	1	Actuator body
14	1	Air fitting angle
16	10	Membrane seal
17	1	Valve body
18	1	Plug for upper connection

Service kits

Denomination

Size 4

Service kit

▲ Service kit 9611924304

8 Parts List and Service Kits

Always use Alfa Laval genuine spare parts.

The warranty of Alfa Laval products is dependent on the use of Alfa Laval genuine spare parts.

8.3 Actuator for USV size 10 double seat

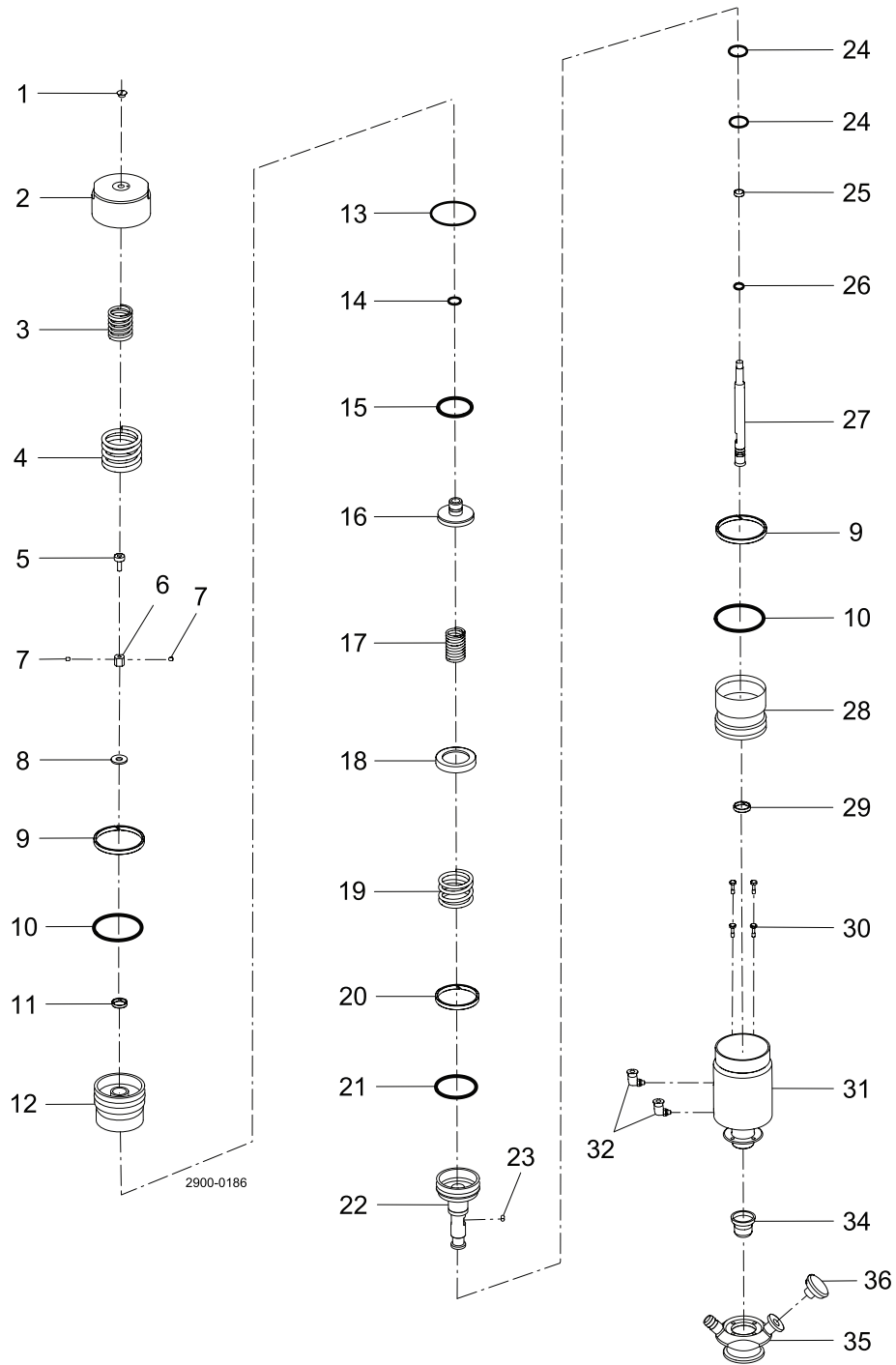

8 Parts List and Service Kits

Always use Alfa Laval genuine spare parts.

The warranty of Alfa Laval products is dependent on the use of Alfa Laval genuine spare parts.

Parts list

Pos.	Qty	Denomination
1	1	Actuator
2	1	Top plug
3	1	Actuator top
4	1	Spring
5	1	Spring
6	1	Adjuster screw
7	1	Adjuster nut
7 ▲	2	Set screw
8	1	Disc
9	2	Guide ring
10 ▲	2	O-ring
11	1	Guide ring
12	1	Main piston top
13 ▲	1	O-ring
14 ▲	1	O-ring
15 ▲	1	O-ring
16	1	Inner seat lift piston
17	1	Spring
18	1	Spring disc
19	1	Spring
20	1	Guide ring
21 ▲	1	O-ring
22	1	Outer seat lift piston
23 ▲	1	Pin
24 ▲	2	O-ring
25	1	Guide ring
26 ▲	1	O-ring
27	1	Inner stem
28	1	Main piston bottom
29	1	Guide ring
30	4	Mount screws
31	1	Actuator body
32	2	Air fitting angle
34	10	Membrane seal
35	1	Valve body
36	1	Plug for upper connection

Service kits

Denomination	Size 10
▲ Service kit	9611924305

8 Parts List and Service Kits

Always use Alfa Laval genuine spare parts.

The warranty of Alfa Laval products is dependent on the use of Alfa Laval genuine spare parts.

8.4 Actuator for USV size 10 single seat

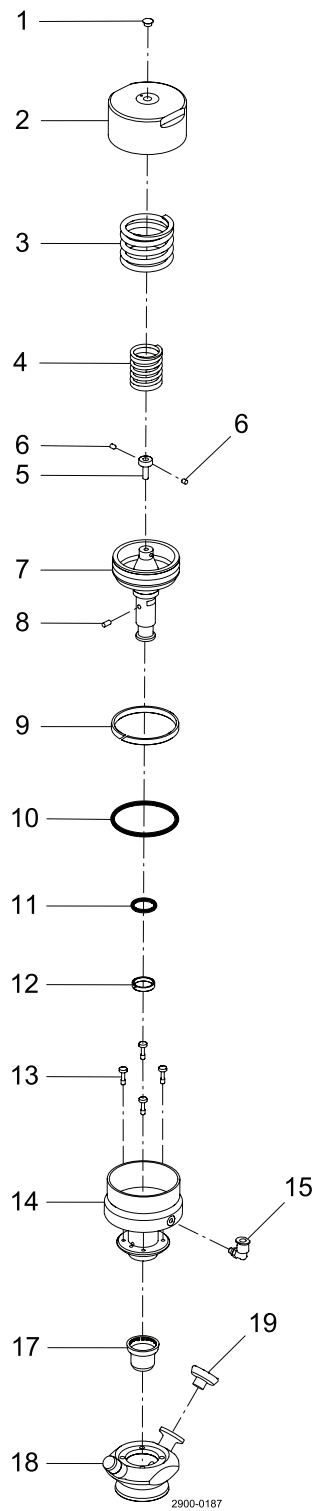

8 Parts List and Service Kits

Always use Alfa Laval genuine spare parts.

The warranty of Alfa Laval products is dependent on the use of Alfa Laval genuine spare parts.

Parts list

Pos.	Qty	Denomination
1	1	Actuator Top plug
2	1	Actuator top
3	1	Spring
4	1	Spring
5	1	Adjuster screw
6 ▲	2	Set screw
7	1	Main piston
8 ▲	1	Pin
9	1	Guide ring
10 ▲	1	O-ring
11 ▲	1	O-ring
12	1	Guide ring
13	4	Mount screws
14	1	Actuator body
15	1	Aiir fitting angle
17	10	Membrane seal
18	1	Valve body
19	1	Plug for upper connection

Service kits

Denomination

Service kit

▲ Service kit 9611924309

8 Parts List and Service Kits

Always use Alfa Laval genuine spare parts.

The warranty of Alfa Laval products is dependent on the use of Alfa Laval genuine spare parts.

8.5 Actuator for USV size 25 double seat

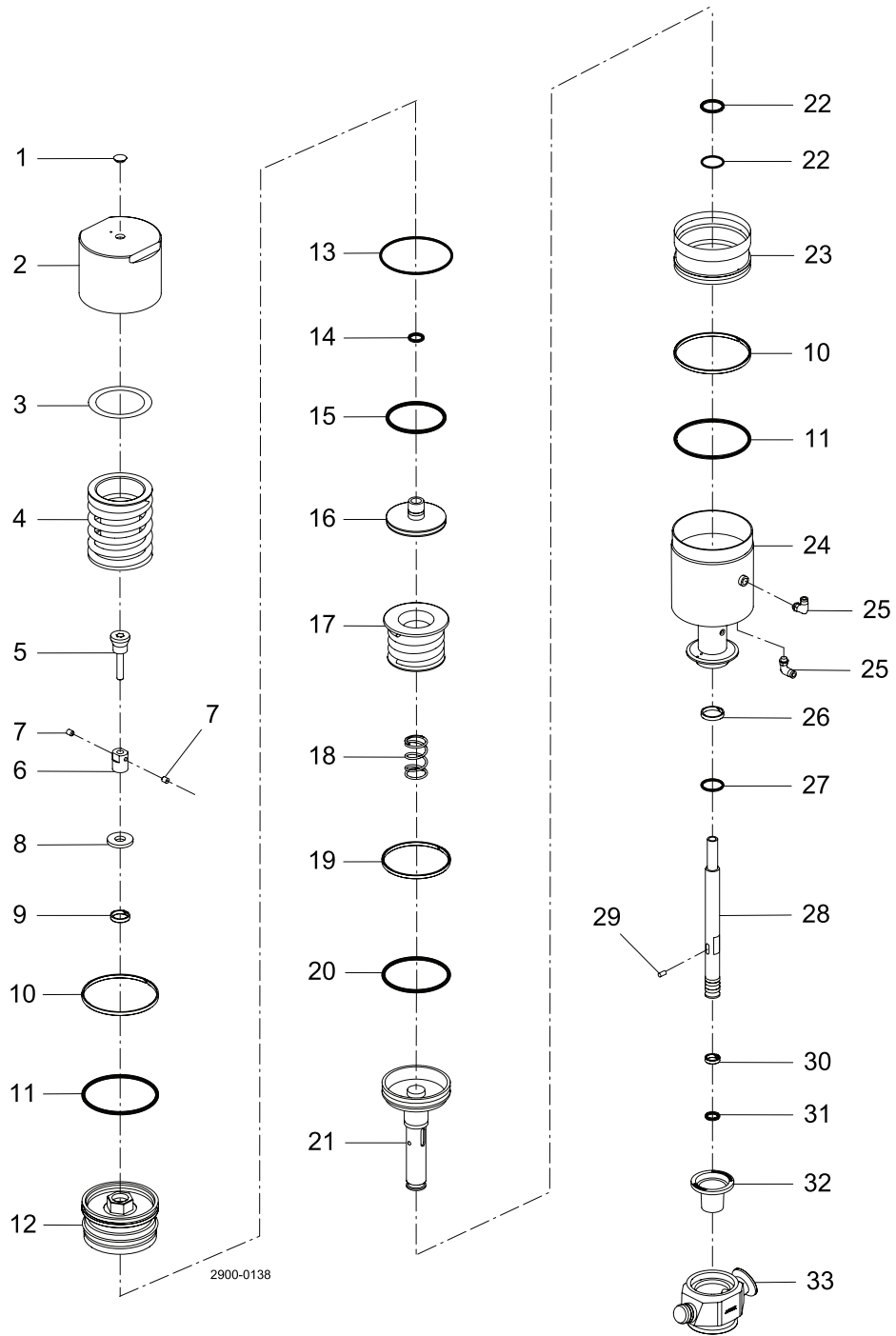

8 Parts List and Service Kits

Always use Alfa Laval genuine spare parts.

The warranty of Alfa Laval products is dependent on the use of Alfa Laval genuine spare parts.

Parts list

Pos.	Qty	Denomination
1	1	Actuator
2	1	Top plug
3	1	Actuator top
4	1	PTFE disc
5	1	Spring
6	1	Adjuster screw
7	1	Nut for adjustment
8 ▲	2	Set screw
9	1	Disc
10	1	Guide ring
11 ▲	2	Guide ring
12	2	O-ring
13	1	Upper piston
14 ▲	1	O-ring
15 ▲	1	O-ring
16	1	O-ring
17	1	Inner piston
18	1	Spring cage
19	1	Spring
20	1	Guide ring
21 ▲	1	O-ring
22 ▲	1	O-ring
23	2	Outer stem
24	1	O-ring
25	1	Lower piston
26	1	Actuator body
27	2	Air fitting
28	1	Guide ring
29 ▲	1	O-ring
30	1	Inner stem
31 ▲	1	Pin
32	1	Guide ring
33	1	O-ring
	10	Membrane seal
	1	Valve body

Service kits

Denomination

Service kit

▲ Service kit 9611924310

8 Parts List and Service Kits

Always use Alfa Laval genuine spare parts.

The warranty of Alfa Laval products is dependent on the use of Alfa Laval genuine spare parts.

8.6 Actuator for USV size 25 single seat

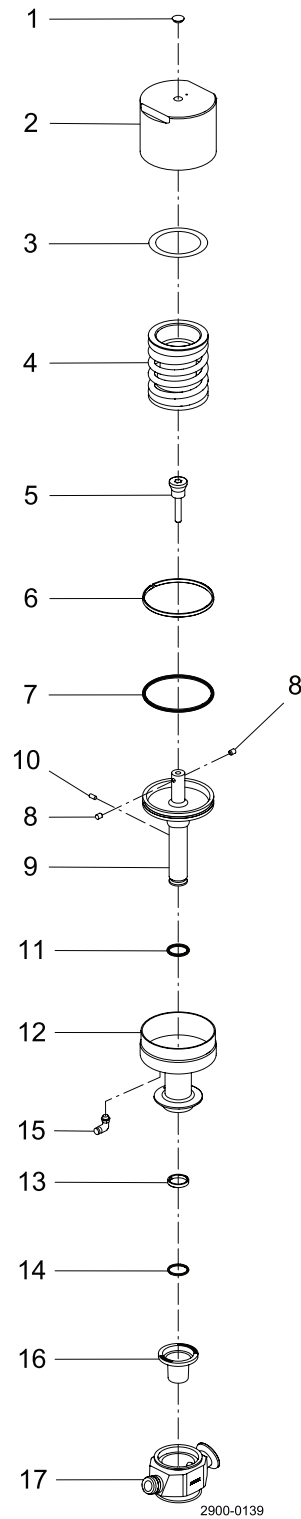

8 Parts List and Service Kits

Always use Alfa Laval genuine spare parts.

The warranty of Alfa Laval products is dependent on the use of Alfa Laval genuine spare parts.

Parts list

Pos.	Qty	Denomination
1	1	Actuator Top plug
2	1	Actuator top
3	1	PTFE disc
4	1	Spring
5	1	Adjuster screw
6	1	Guide ring
7 ▲	1	O-ring
8 ▲	2	Set screw
9	1	Main piston
10 ▲	1	Pin
11 ▲	1	O-ring
12	1	Actuator body
13	1	Guide ring
14 ▲	1	O-ring
15	1	Air fitting
16	10	Membrane seal
17	1	Valve body

Service kits

Denomination

Service kit

▲ Service kit 9611924311

How to contact Alfa Laval

Contact details for all countries are continually updated on our website.

Please visit www.alfalaval.com to access the information directly.

© Alfa Laval Corporate AB

This document and its contents is owned by Alfa Laval Corporate AB and protected by laws governing intellectual property and thereto related rights. It is the responsibility of the user of this document to comply with all applicable intellectual property laws. Without limiting any rights related to this document, no part of this document may be copied, reproduced or transmitted in any form or by any means (electronic, mechanical, photocopying, recording, or otherwise), or for any purpose, without the expressed permission of Alfa Laval Corporate AB. Alfa Laval Corporate AB will enforce its rights related to this document to the fullest extent of the law, including the seeking of criminal prosecution.