

Alfa Laval TK20 Semi-welded

Gasketed plate heat exchanger for demanding applications

Introduction

Alfa Laval Industrial semi-welded line is used when gaskets are not suitable for one of the process media. The semi-welded line can also withstand a higher design pressure compared to fully gasketed plate-and-frame heat exchangers.

The relatively short plate makes this model suitable for duties with short temperature programs and when a low pressure drop is appreciated. A large range of plate and gasket types is available.

Applications

- Chemicals
- Energy and Utilities
- Food, Dairy and Beverages
- HVAC and Refrigeration
- Marine and Transportation
- Mining, Minerals and Pigments
- Pulp and Paper
- Steel
- Water and Waste treatment

Benefits

- High energy efficiency – low operating cost
- Flexible configuration – heat transfer area can be modified
- Easy to install – compact design
- High serviceability – easy to open for inspection and cleaning and easy to clean by CIP
- Access to Alfa Laval's global service network

Features

Every detail is carefully designed to ensure optimal performance, maximum uptime and easy maintenance. Selection of available features, depending on configuration some features may not be applicable:



- Five-point alignment
- T-bar roller
- CurveFlow™ distribution area
- ClipGrip™ gasket attachment
- Leak chamber
- RefTight™ sealing system
- Compact frame
- Bearing boxes

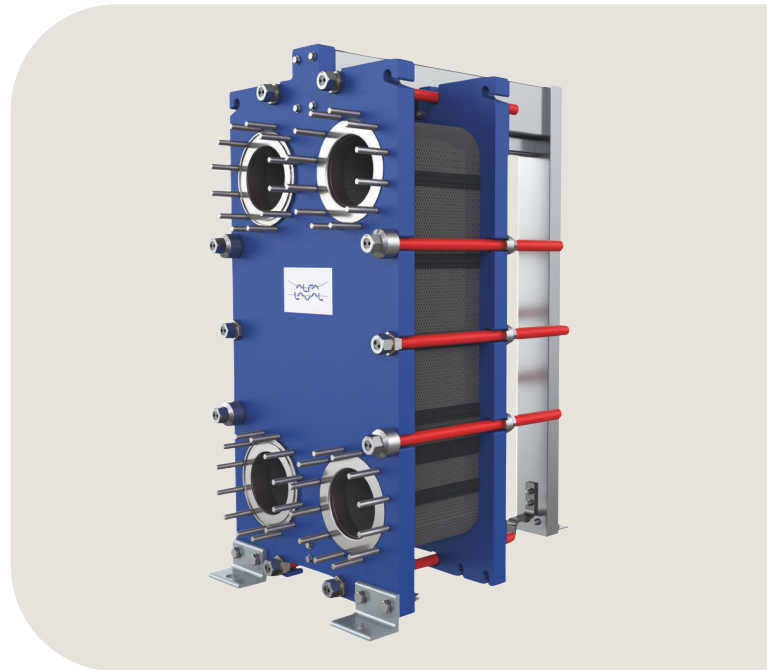

- Fixed bolt head
- Key hole bolt opening
- Lifting lug
- Lining
- Lock washer
- Swing feet
- Tightening bolt cover
- Optimized Alfa Laval drain connection

Alfa Laval 360° Service Portfolio

Our extensive service offering ensure top performance from your Alfa Laval equipment throughout its life cycle. The Alfa Laval 360 Service Portfolio include installation services, cleaning and repair as well as spare parts, technical documentation and trouble shooting. We also offer replacement, retrofit, integrity testing, monitoring and much more.

For information about our complete service offering and how to contact us - please visit www.alfalaval.com/service.

General remarks for technical information

- The global offering presented in this leaflet may not be available for all regions
- All combinations may not be configurable

Dimensional drawing

Measurements mm (inches)

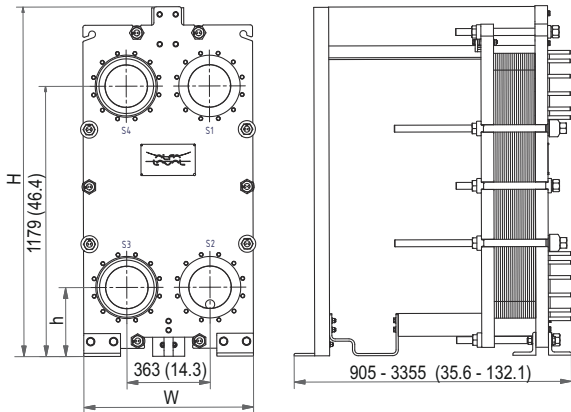

Frame type	H	W	h
FG	1525 (60.0")	740 (29.1")	301 (11.9")
FD	1525 (60.0")	785 (30.9")	301 (11.9")
FX	1560 (61.4")	900 (35.4")	331 (13.0")

The number of tightening bolts may vary depending on pressure rating.

Technical data

Plates	Type	Free channel, mm (inches)
TK20-BW	Semi-welded	2.5 (0.098)

Materials

Heat transfer plates	304/304L, 316/316L, 254 Ti
Field gaskets	NBR, EPDM, FKM NBR, EPDM, CR
Ring gaskets	NBR, EPDM, CR, HeatSeal
Flange connections	Metal lined: stainless steel, Alloy 254, titanium
Frame and pressure plate	Carbon steel, epoxy painted

Other materials may be available on request.

Operational data

Frame type	Max. design pressure barg (psig)	Max. design temperature °C (°F)
FG, pvcALS	15.5 (225)	200 (392)
FG, PED	16.0 (232)	50 (122)
FD, pvcALS	25.0 (362)	150 (302)
FD, ASME	20.7 (300)	150 (302)
FD, PED	25.0/362	150 (302)
FX, ASME	62.1 (900)	250 (482)
FX, PED	63.0 (914)	150 (302)

Extended pressure and temperature rating may be available on request.

Flange connections

Frame type	Connection standard	
FG, pvcALS	EN 1092-1 DN150 PN16	
	EN 1092-1 DN200 PN16	
	ASME B16.5 Class 150 NPS 6 ASME B16.5 Class 150 NPS 8 JIS B2220 16K 200A	
FG, PED	EN 1092-1 DN150 PN16	
	EN 1092-1 DN200 PN16	
	ASME B16.5 Class 150 NPS 6 ASME B16.5 Class 150 NPS 8	
FD, pvcALS	EN 1092-1 DN150 PN25	
	EN 1092-1 DN200 PN25	
	ASME B16.5 Class 300 NPS 6 ASME B16.5 Class 300 NPS 8 JIS B2220 20K 200A	
FD, ASME	ASME B16.5 Class 300 NPS 6 ASME B16.5 Class 300 NPS 8	
	FD, PED	EN 1092-1 DN200 PN16
EN 1092-1 DN200 PN25		
EN 1092-1 DN200 PN40 ASME B16.5 Class 300 NPS 6 ASME B16.5 Class 300 NPS 8		
FX, ASME	ASME B16.5 Class 150 NPS 8 ASME B16.5 Class 300 NPS 6 ASME B16.5 Class 300 NPS 8 ASME B16.5 Class 900 NPS 6 ASME B16.5 Class 600 NPS 6	
	FX, PED	EN 1092-1 DN200 PN16
		EN 1092-1 DN200 PN25
EN 1092-1 DN150 PN63 ASME B16.5 Class 150 NPS 8 ASME B16.5 Class 900 NPS 6		

Standard EN1092-1 corresponds to GOST 12815-80 and GB/T9124.1.

This document and its contents are subject to copyrights and other intellectual property rights owned by Alfa Laval Corporate AB. No part of this document may be copied, re-produced or transmitted in any form or by any means, or for any purpose, without Alfa Laval Corporate AB's prior express written permission. Information and services provided in this document are made as a benefit and service to the user, and no representations or warranties are made about the accuracy or suitability of this information and these services for any purpose. All rights are reserved.

How to contact Alfa Laval

Up-to-date Alfa Laval contact details for all countries are always available on our website at www.alfalaval.com