

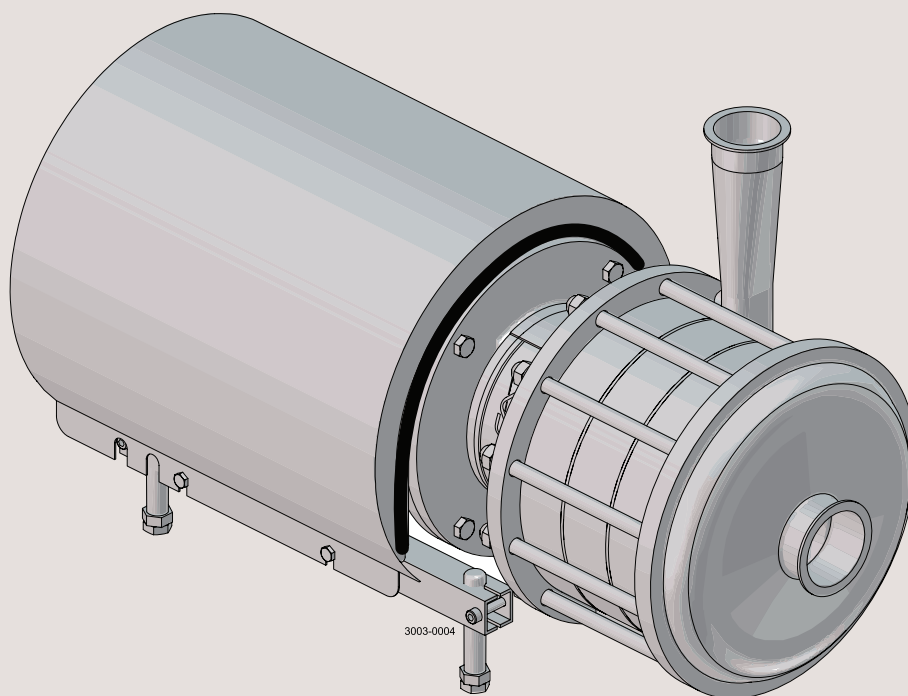

# Instruction Manual

LKH Multi-Stage Pump



100002859-EN9 2022-10

Original manual



# Table of contents

*The information herein is correct at the time of issue but may be subject to change without prior notice*

1. Declarations of Conformity .....	4
2. Safety .....	6
2.1. Important information .....	6
2.2. Warning signs .....	7
2.3. Safety precautions .....	8
3. Installation .....	10
3.1. Unpacking/delivery .....	10
3.2. Installation/Pre-use Check .....	12
3.3. Recycling information .....	17
4. Operation .....	18
4.1. Operation/Control .....	18
4.2. Trouble shooting .....	21
4.3. Recommended cleaning .....	22
5. Maintenance .....	24
5.1. General maintenance .....	24
5.2. Cleaning Procedure .....	28
5.3. Dismantling of pump/shaft seals .....	29
5.4. Assembly of Pump/Assembly of Shaft Seal – LKH-110 .....	33
5.5. Assembly of Pump/Assembly of Shaft Seal – LKH-120/P .....	38
6. Technical data .....	43
6.1. Technical data .....	43
6.2. Relubrication intervals .....	45
6.3. Torque Specifications .....	45
6.4. Weight (kg) .....	46
6.5. Noise emission .....	47
7. Parts list and service kits .....	48
7.2. LKH Multi-Stage – Wet end .....	49
7.3. LKH Multi-Stage – Motor dependent parts .....	51
7.4. LKH Multi-Stage – Shaft seal and Service kits .....	53

# 1 Declarations of Conformity

## EU Declaration of Conformity

The Designated Company

Alfa Laval Kolding A/S, Albuen 31, DK-6000 Kolding, Denmark, +45 79 32 22 00

Company name, address and phone number

Hereby declare that

Pump

Designation

LKH-112, LKH-112/P, LKH-113, LKH-113/P, LKH-114, LKH-114/P, LKH-122/P, LKH-123/P, LKH-124/P

Type

Serial number from 10.000 to 1.000.000

is in conformity with the following directives with amendments:

- Machinery Directive 2006/42/EC
- RoHS EU Directive 2011/65/EU and amendments

The person authorised to compile the technical file is the signer of this document.

Global Product Quality Manager

Title

Lars Kruse Andersen

Name

Kolding, Denmark

Place

2022-10-01

Date (YYYY-MM-DD)



Signature

This Declaration of Conformity replaces Declaration of Conformity dated 2013-12-03



# 1 Declarations of Conformity

## UK Declaration of Conformity

The Designated Company

Alfa Laval Kolding A/S, Albuen 31, DK-6000 Kolding, Denmark, +45 79 32 22 00

Company name, address and phone number

Hereby declare that

Pump

Designation

LKH-112, LKH-112/P, LKH-113, LKH-113/P, LKH-114, LKH-114/P, LKH-122/P, LKH-123/P, LKH-124/P

Type

Serial number from 10.000 to 1.000.000

is in conformity with the following directives with amendments:

- The Supply of Machinery (Safety) Regulations 2008
- The Restriction of the Use of Certain Hazardous Substances in Electrical and Electronic Equipment Regulations 2012

Signed on behalf of: Alfa Laval Kolding A/S

Global Product Quality Manager

Title

Lars Kruse Andersen

Name

Kolding, Denmark

Place

2022-10-01

Date (YYYY-MM-DD)



Signature

DoC Revison\_01\_102022

**UK  
CA**



## 2 Safety

---

*Unsafe practices and other important information are emphasized in this manual.  
Warnings are emphasized by means of special signs.  
**Always read the manual before using the pump!***

---

### 2.1 Important information

---

#### **WARNING**

Indicates that special procedures must be followed to avoid serious personal injury.

#### **CAUTION**

Indicates that special procedures must be followed to avoid damage to the pump.

#### **NOTE**

Indicates important information to simplify or clarify procedures.

---

**This Instruction manual is designed to provide the user with the information to perform tasks safely for all phases in the life time of the product supplied.**

**The User shall always read the safety section first. Hereafter the User can skip to the relevant section for the task to be carried out or for the information needed.**

**This is the complete manual for the supplied product.**

**Skills for personal:**

**Operators:**

**The operators shall read and understand the instruction manual for the supplied product**

**Maintenance personnel:**

**The maintenance personnel shall read and understand the instruction manual.**

**The maintenance personnel or technicians shall be skilled within the field required to carry out the maintenance work safely.**

**Trainees:**

**Trainees can perform tasks under the supervision of an experienced employee.**

**People in general:**

**The public shall not have access to the supplied product.**

---

#### **How to contact Alfa Laval**

Contact details for all countries are continually updated on our website.

Please visit [www.alfalaval.com](http://www.alfalaval.com) to access the information directly.

---

---

*Unsafe practices and other important information are emphasized in this manual.  
Warnings are emphasized by means of special signs.  
**Always read the manual before using the pump!***

---

### 2.2 Warning signs

---

**General warning:**



**Dangerous electrical voltage:**



**Caustic agents:**



## 2 Safety

---

*All warnings in the manual are summarized on this page.*

*Pay special attention to the instructions below so that severe personal injury and/or damage to the pump are avoided.*

---

### 2.3 Safety precautions

---

#### General

**Always** ensure that personnel must have experience with lifting operations.

**Always** ensure the lifting point to be in line with center of gravity. Adjust lifting point if necessary.

**Always** keep an eye on the load and stay clear during the lifting operation.

**Always** ensure that the lifting equipment is suitable for the specific pump.

**Always** use appropriate lifting equipment for heavy parts when relevant. Use lifting logs when applied.

To prevent unexpected start and contact with electrical live and moving parts.

**Always** disconnect the power supply safely:

– The power supply disconnecting device must be disconnected (in off position) and locked.

– In case the pump is capable of being plugged into an electrical supply, removal of the plug is sufficient, provided that the operator can check from any of the points to which he has access that the plug remains removed.

**Always** refer to the motor instruction manual for installation and maintenance of the motor.

**Never** touch the impeller through the inlet/outlet during start/stop as this can cause serious injury.

#### Installation:

**Always** read the technical data thoroughly. (See chapter 6 Technical data)



#### Pump without impeller screw:

**Always** remove the impeller before checking the direction of rotation.

**Never** start the pump if the impeller is fitted and the pump casing is removed.



#### Pump with Impeller screw:

**Never** start in the wrong direction of rotation with liquid in the pump.

**Always** have the pump electrically connected by authorised personnel. (See the motor instruction)



#### Operation:

**Always** read the technical data thoroughly. (See chapter 6 Technical data)

**Never** touch the pump or the pipelines when pumping hot liquids or when sterilising.

**Never** run the pump with both the suction side and the pressure side blocked.

**Never** run the pump when partially installed or not completely assembled.

**Necessary** precautions must be taken if leakage occurs as this can lead to hazardous situations.

**Always** handle lye and acid with great care.

**Never** use the pump for products not mentioned in the Alfa Laval pump selection program.

The Alfa Laval pump selection program can be acquired from your local Alfa Laval sales company.



#### Maintenance:

**Always** read the technical data thoroughly. (See chapter 6 Technical data)

**Never** service the pump when it is hot.

**Never** service the pump if pressurised.

**Always** use Alfa Laval genuine spare parts.



#### Motors with grease nipples:

**Always** lubricate according to motor manufacturer's recommended procedures.

**Always** locate and remove grease vent plugs, if provided, prior to adding grease.

**Always** check motor nameplate for grease type and lubrication intervals.





*All warnings in the manual are summarized on this page.*

*Pay special attention to the instructions below so that severe personal injury and/or damage to the pump are avoided.*

---

### **Transportation:**

#### **Transportation of the pump or the pump unit:**

**Never** lift or elevate in any way other than described in this manual

**Always** drain the pump head and accessories of any liquid

**Always** ensure that no leakage of lubricants can occur

**Always** transport the pump in its upright position

**Always** ensure that the unit is securely fixed during transportation

**Always** use the original packaging or similar during transportation

**Always** use suitable transport device ie. forklift or pallet lifter

### **Storage:**

Ideally as a guide Alfa Laval would recommend:

- Store supplied product as supplied in original packaging
  - Port opening should be protected against any ingress
  - Bare steel (not stainless) should be lightly oiled/greased
  - Store in a clean, dry place without direct sunlight or UV light
  - Temperature range -5 to 40°C
  - Relative humidity less than 60%
  - No exposure to corrosive substances (also air contained)
-

## 3 Installation

The LKH-110 and -120P pump is highly efficient and economical centrifugal pump, which meets the requirements of sanitary and gently product treatment and chemical resistance. LKH-110 and the LKH-120P is available in the following sizes, LKH-112, -113, -114 and LKH122/P, -123/P, -124/P. The instruction manual is part of the delivery. Study the instructions carefully. The large pump sizes are very heavy. Alfa Laval recommends the use of a lifting crane when handling the pump.

### 3.1 Unpacking/delivery

#### Step 1



**Always** use a lifting crane when handling the pump

#### CAUTION

Alfa Laval cannot be held responsible for incorrect unpacking.

#### WARNING:

Be aware that certain pump configurations can tilt, and thereby cause injuries to feet or fingers. The pump should be supported underneath the adaptor, when not installed in the process line.

#### Check the delivery for:

1. Complete pump.
2. Delivery note.
3. Instruction manual.
4. Motor instructions.
5. Test certificate, IF ORDERED!

#### Step 2

Remove possible packing materials from the inlet and the outlet.

Avoid damaging the inlet and the outlet.

Avoid damaging the connections for flushing liquid, if supplied.

\* Remove packing materials!

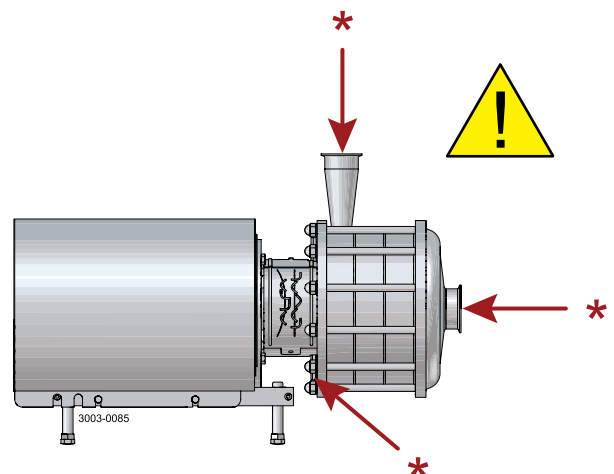

#### Step 3

Inspect the pump for visible transport damages.

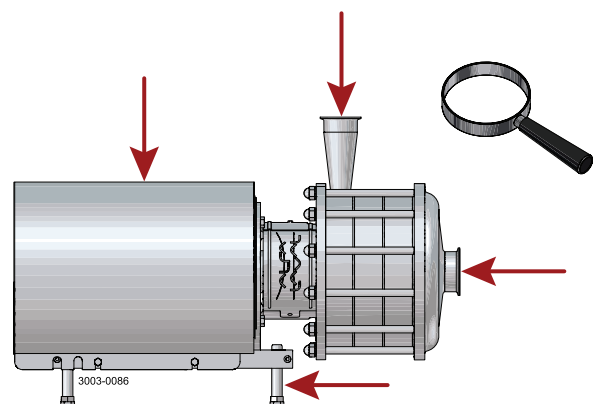

### 3 Installation

---

*The LKH-110 and -120P pump is highly efficient and economical centrifugal pump, which meets the requirements of sanitary and gently product treatment and chemical resistance. LKH-110 and the LKH-120P is available in the following sizes, LKH-112, -113, -114 and LKH122/P, -123/P, -124/P. The instruction manual is part of the delivery. Study the instructions carefully. The large pump sizes are very heavy. ALfa Laval recommends the use of a lifting crane when handling the pump.*

---

#### **Step 4**

Always remove the shroud, if fitted, before lifting the pump.

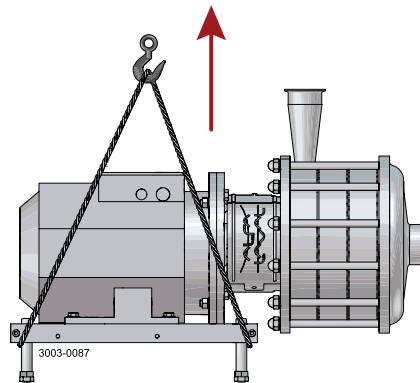

## 3 Installation

*Study the instructions carefully and pay special attention to the warnings!*

*The direction of rotation of the impeller can be checked by observing the direction of rotation of the motor fan.  
– See the indication label on the pump.*

### 3.2 Installation/Pre-use Check

#### Step 1



**Always** read the technical data thoroughly.  
(See chapter 6 Technical data)

Never start in the wrong direction of rotation with liquid in the pump. See step 6 Pre-use check



**Always** use a lifting crane when handling the pump.



**Always** have the pump electrically connected by authorised personnel. (See the motor instructions).

#### CAUTION

Alfa Laval cannot be held responsible for incorrect installation.

#### CAUTION

The pump does not prevent back flow when intentionally or unintentionally stopped. If back flow can cause any hazardous situations, precautions must be taken e.g. check the valve to be installed in the system preventing hazardous situations from arising.

#### CAUTION

If the pump has been stored for longer period of time there is a risk that the seal faces may stick together and consequently cause damage to the seal at start-up. Please ensure that the pump shaft can be rotated by hand before start-up.

#### WARNING:

Alfa Laval recommends the supply disconnecting device shall be in accordance with EN60204-1. Always disconnect the supply disconnecting device safely after installation before continuing the installation.

#### Step 2

Ensure at least 0.5 m (1.6 ft) clearance around the pump.

Ensure the floor/frame is able to support the weight of the pump. See Technical data and other environment requirements in section 6.

Ensure the pump is supported by all four feet equally.

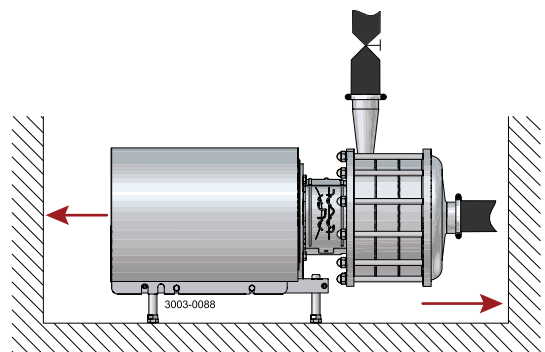

*Study the instructions carefully and pay special attention to the warnings!*

*The direction of rotation of the impeller can be checked by observing the direction of rotation of the motor fan.*

*– See the indication label on the pump.*

### Step 3

Check that the flow direction is correct.

O: Outlet

I: Inlet

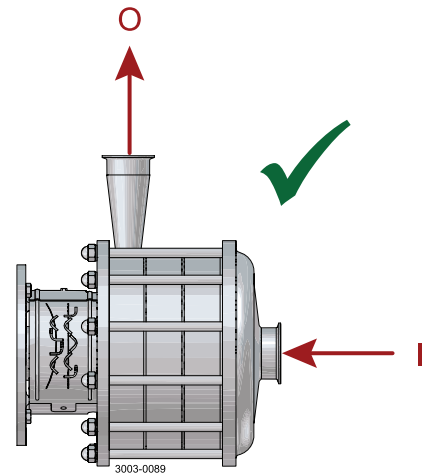

### Step 4

1. Ensure that the pipelines are routed correctly.

2. Ensure that the connections are tight.

3. Remember seal rings. Few bends

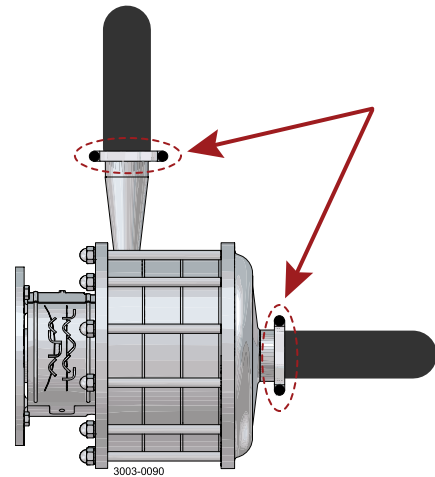

### 3 Installation

*Study the instructions carefully and pay special attention to the warnings!*

*The direction of rotation of the impeller can be checked by observing the direction of rotation of the motor fan.*

*– See the indication label on the pump.*

#### Step 5

**Avoid stressing the pump.**

**Piping system must be self-supported.**

**Pay special attention to:**

- Vibrations.
- Thermal expansion of the tubes.
- Excessive welding.
- Overloading of the pipelines.

Example of piping system self-supported.

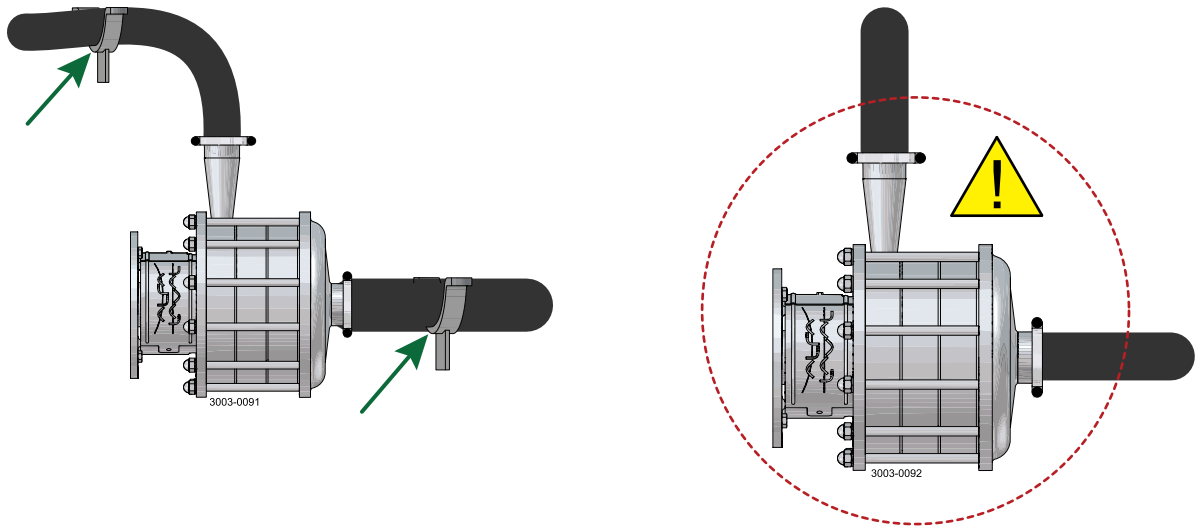

#### Step 6

Ensure correct alignment of pump inlet and outlet with piping system.

Alignment can be done by adjusting the pump legs.

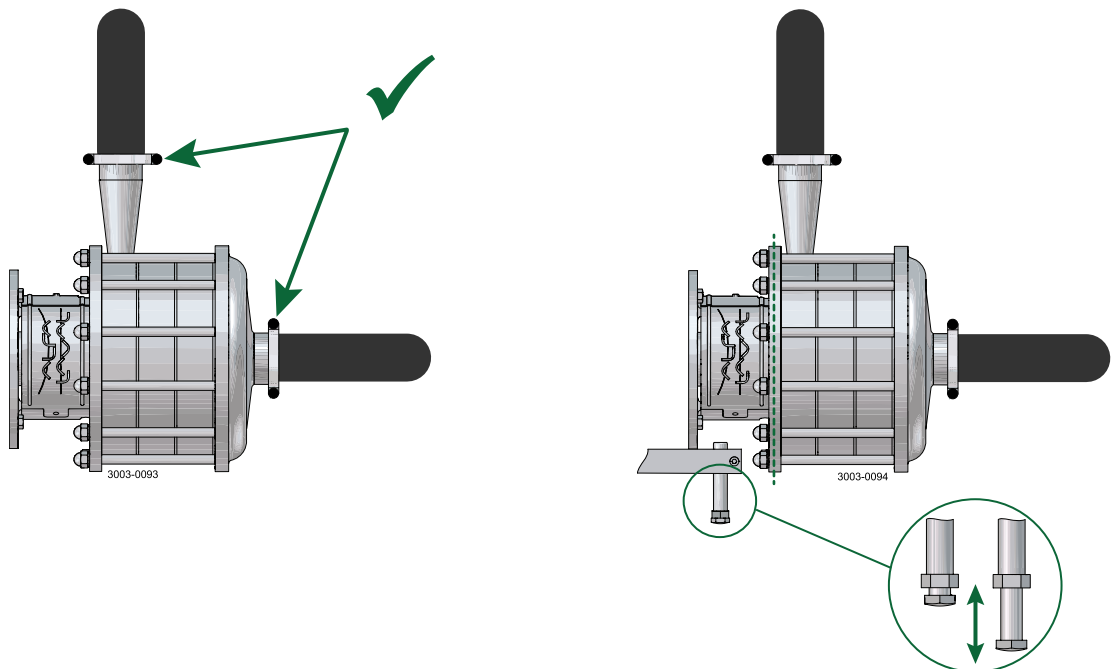

*Study the instructions carefully and pay special attention to the warnings!*

*The direction of rotation of the impeller can be checked by observing the direction of rotation of the motor fan.*

*– See the indication label on the pump.*

Centre of inlet and outlet to be aligned with centre of piping system.

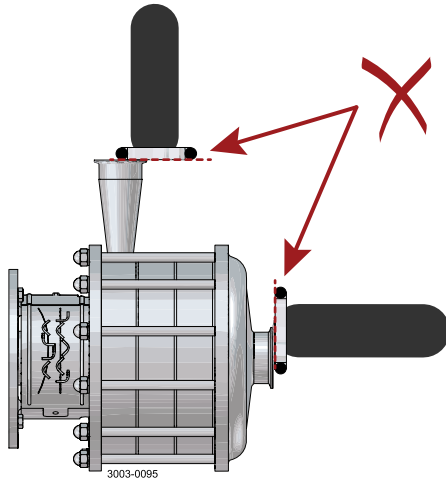

No gaps between connections on pump inlet and inlet pipe, and pump outlet and outlet pipe.

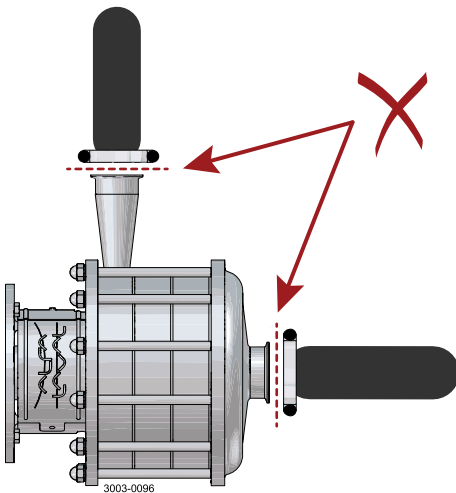

Angle between connections on pump inlet and inlet pipe, pump outlet and outlet pipe not allowed.

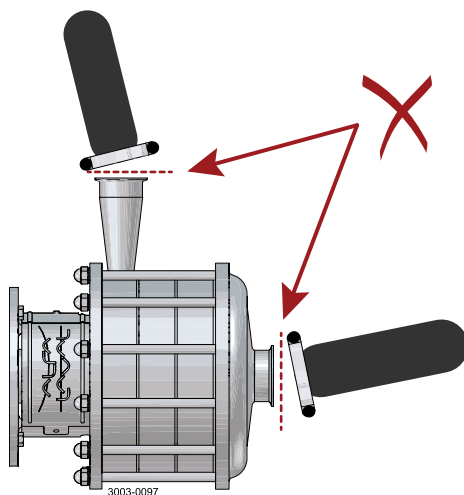

### 3 Installation

---

*Study the instructions carefully and pay special attention to the warnings!*

*The direction of rotation of the impeller can be checked by observing the direction of rotation of the motor fan.*

*– See the indication label on the pump.*

---

#### Note

In case of shaft seal leakage, the media will drip from the slot in the bottom of the adaptor. In case of shaft seal leakage, Alfa Laval recommends putting a drip tray underneath the slot to collect the leakage.

#### Step 7



**Never** start in the wrong direction of rotation with liquid in the pump

**Always** ensure the adaptor shield and motor fan guard are present and mounted correctly and allow no access to rotating parts before installing and starting the pump.

Pre-use check:

1. Connect power supply
2. Start and stop the motor momentarily.
3. Ensure that the direction of rotation of the motor fan is clockwise as viewed from the rear end of the motor.
4. Disconnect power supply safely.

\* Correct rotation direction! See the indication label!

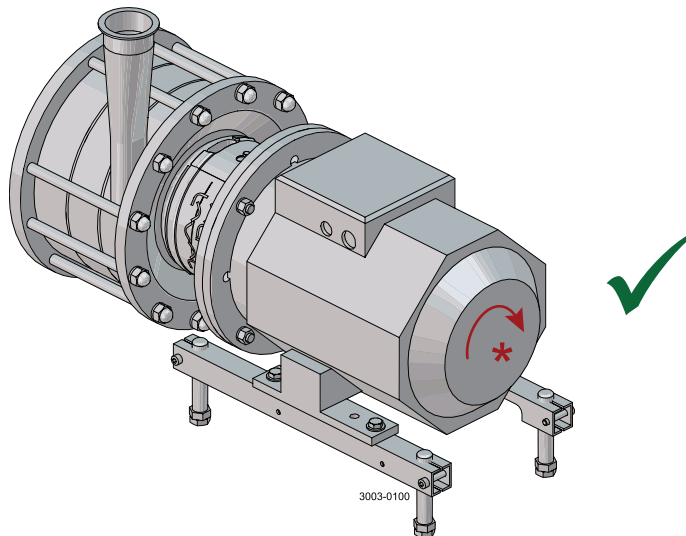



### 3.3 Recycling information

---

- **Unpacking**

- Packing material consists of wood, plastics, cardboard boxes and in some cases metal straps.
- Wood and cardboard boxes can be reused, recycled or used for energy recovery.
- Plastics should be recycled or burnt at a licensed waste incineration plant.
- Metal straps should be sent for material recycling.

- **Maintenance**

- During maintenance oil and wear parts in the machine are replaced.
- All metal parts should be sent for material recycling.
- Worn out or defective electronic parts should be sent to a licensed handler for material recycling.
- Oil and all non metal wear parts must be taken care of in agreement with local regulations.

- **Scrapping**

- At end of use, the equipment shall be recycled according to relevant, local regulations. Beside the equipment itself, any hazardous residues from the process liquid must be considered and dealt with in a proper manner. When in doubt, or in the absence of local regulations, please contact the local Alfa Laval sales company.
-

## 4 Operation

*Study the instructions carefully and pay special attention to the warnings!*

### 4.1 Operation/Control

#### Step 1



**Always** read the technical data thoroughly. See chapter 6 Technical data

#### CAUTION

Alfa Laval cannot be held responsible for incorrect operation/control.



**Never** touch the pump or the pipelines when pumping hot liquids or when sterilising.

#### Step 2



**Never** touch the pump or the pipelines when pumping hot liquids or when sterilising.

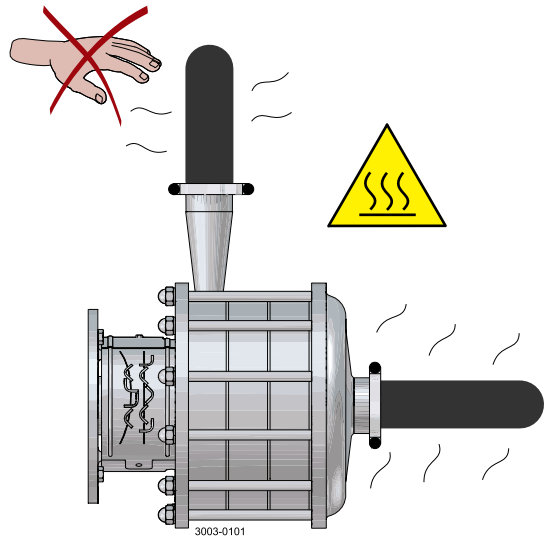

#### Step 3



**Never** run the pump with both the suction side and the pressure side blocked.

\* **Danger of explosion!** See warning label on pump.

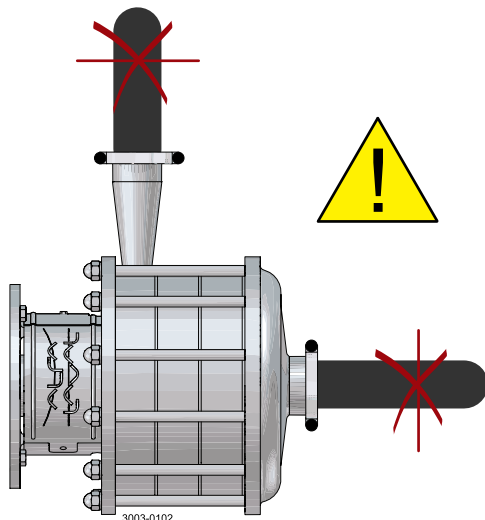

*Study the instructions carefully and pay special attention to the warnings!*

**Step 4**

**CAUTION**

The shaft seal must not run dry.

**CAUTION**

Never throttle the inlet side.

\* Do not allow to run dry

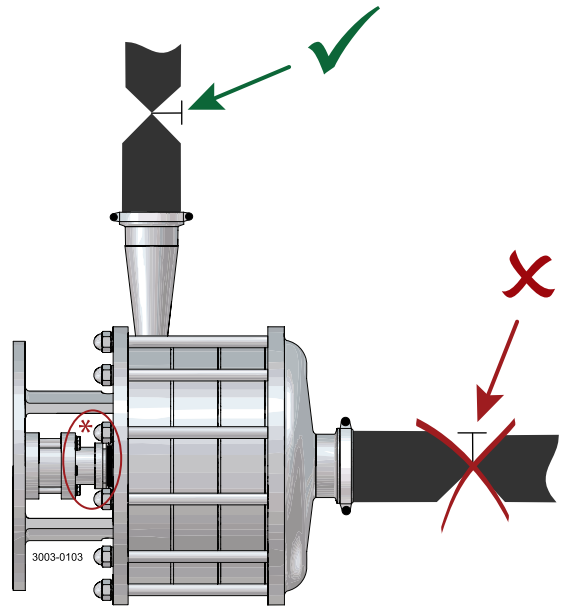

**Step 5**

**Flushed shaft seal:**

1. Connect the inlet of the flushing liquid correctly.
2. Regulate the water supply correctly.
3. Observe the steam data.

O: Outlet

I: Inlet

$T_{max} = 100^{\circ}C$

$P_{max} = 1 \text{ bar}$

(flush seal)

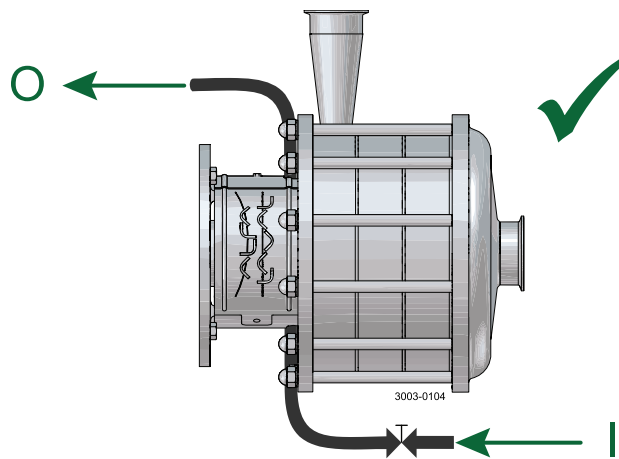

## 4 Operation

---

*Study the instructions carefully and pay special attention to the warnings!*

---

### Step 6

#### Control:

Reduce the capacity and the power consumption by means of:

- Throttling the pressure side of the pump.
- Reducing the impeller diameter.
- Reducing the speed of the motor.

\* Throttling!

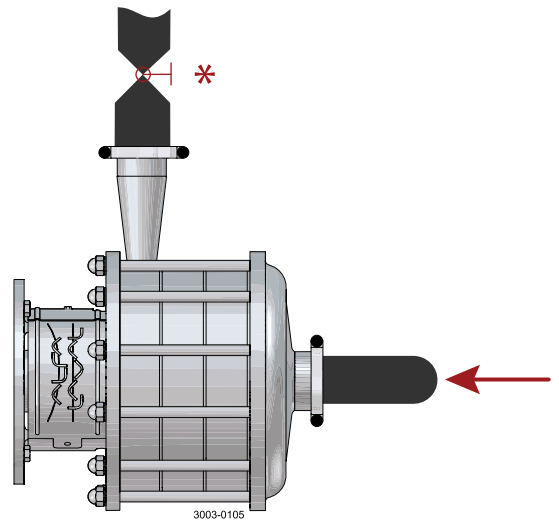

*Pay attention to possible faults.  
Study the instructions carefully.*

## 4.2 Trouble shooting

### NOTE!

Study the maintenance instructions carefully before replacing worn parts. – See section 5.1 General maintenance

Problem	Cause/result	Remedy
Overloaded motor	<ul style="list-style-type: none"> <li>- Pumping of viscous liquids</li> <li>- Pumping of liquids with high density</li> <li>- Low outlet pressure (counter pressure)</li> <li>- Lamination of precipitates from the liquid</li> </ul>	<ul style="list-style-type: none"> <li>- Larger motor or smaller impeller</li> <li>- Higher counter pressure (throttling)</li> <li>- Frequent cleaning</li> </ul>
<ul style="list-style-type: none"> <li>- Damage</li> <li>- Pressure reduction (sometimes to zero)</li> <li>- Increasing of the noise level</li> </ul>	<ul style="list-style-type: none"> <li>- Low inlet pressure</li> <li>- High liquid temperature</li> </ul>	<ul style="list-style-type: none"> <li>- Increase the inlet pressure</li> <li>- Reduce the liquid temperature</li> <li>- Reduce the pressure drop before the pump</li> </ul>
Leaking shaft seal	<ul style="list-style-type: none"> <li>- Dry run</li> <li>- Incorrect rubber grade</li> <li>- Abrasive particles in the liquid</li> </ul>	Replace: All wearing parts  If necessary: <ul style="list-style-type: none"> <li>- Change rubber grade</li> <li>- Select stationary and rotating seal ring in Silicon Carbide/Silicon Carbide</li> </ul>
Leaking O-ring seals	Incorrect rubber grade	Change rubber grade

## 4 Operation

The pump is designed for cleaning in place (CIP). CIP = Cleaning In Place.  
Study the instructions carefully and pay special attention to the warnings!  
NaOH = Caustic Soda.  
HNO<sub>3</sub> = Nitric acid.

### 4.3 Recommended cleaning

#### Step 1



**Always** handle lye and acid with great care.  
**Always** follow the instructions in the safety data sheet for the cleaning agent.

**Caustic danger!**



Always use rubber gloves!



Always use protective goggles!

#### Step 2



**Never** touch the pump or the pipelines when sterilizing.

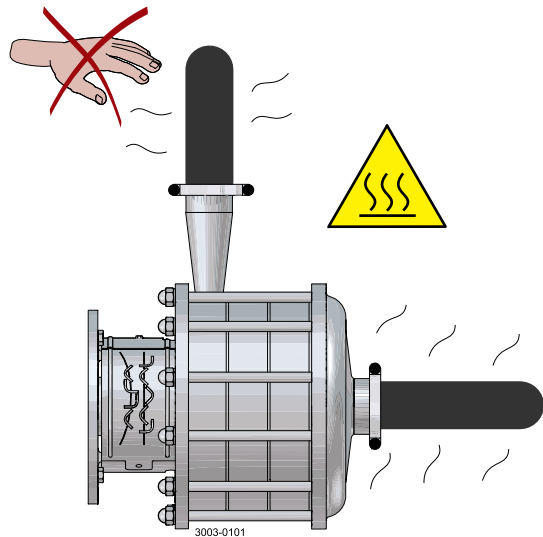

#### Step 3

**Examples of cleaning agents:** Use clean water, free from chlorides.

1. 1% by weight NaOH at 70°C (158°F).

1 kg (2.2 lb) NaOH	+	100 l (26.4 gal) water	= Cleaning agent.
-----------------------	---	---------------------------	-------------------

2.2 l (0.6 gal) 33% NaOH	+	100 l (26.4 gal) water	= Cleaning agent.
-----------------------------	---	---------------------------	-------------------

2. 0.5% by weight HNO<sub>3</sub> at 70°C (158°F).

0.7 l (0.2 gal) 53% HNO <sub>3</sub>	+	100 l (26.4 gal) water	= Cleaning agent.
---	---	---------------------------	-------------------

1. Avoid excessive concentration of the cleaning agent  
⇒ Dose gradually!
2. Adjust the cleaning flow to the process.  
Sterilization of milk/viscous liquids  
⇒ Increase the cleaning flow!

---

*The pump is designed for cleaning in place (CIP). CIP = Cleaning In Place.  
Study the instructions carefully and pay special attention to the warnings!  
NaOH = Caustic Soda.  
HNO<sub>3</sub> = Nitric acid.*

---

### Step 4



**Always** rinse well with clean water after using a cleaning agent.

#### NOTE

The cleaning agents must be stored/disposed of in accordance with current regulations/directives.

#### NOTE

If pumps are sterilised using steam, standard 3A requires the process system to be designed to automatically shut down if the product pressure in the system becomes less than that of the atmosphere and it cannot be started until the system is re-sterilised.

---

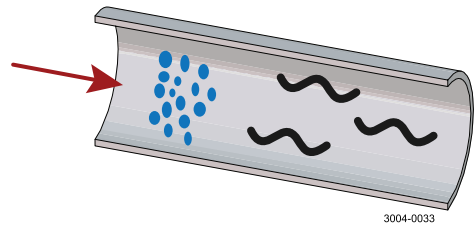

## 5 Maintenance

*Maintain the pump carefully. Study the instructions carefully and pay special attention to the warnings!  
Always keep spare shaft seals and rubber seals in stock.  
See separate motor instructions.*

### 5.1 General maintenance

#### Step 1



**Always** read the technical data thoroughly. See chapter 6 Technical data



**Always** disconnect the power supply when servicing the pump.

#### NOTE

All scrap must be stored/discharged in accordance with current rules/directives.

#### Step 2



**Never** service the pump when it is hot.



**Never** service the pump with pump and pipelines under pressure.

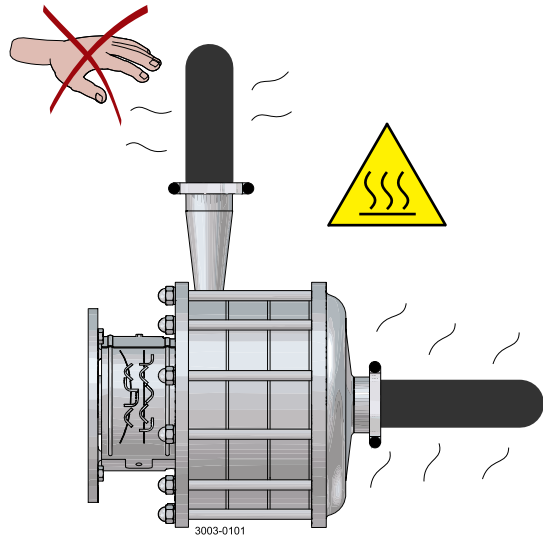

#### Step 3



**Never** service the pump when pump is pressurised.

#### CAUTION

Fit the electrical connections correctly if they have been removed from the motor during service.

#### CAUTION

Pay special attention to the warnings!

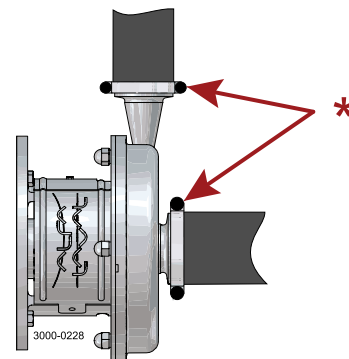

\*) Atmospheric pressure required!



*Maintain the pump carefully. Study the instructions carefully and pay special attention to the warnings!  
Always keep spare shaft seals and rubber seals in stock.  
See separate motor instructions.*

---

### **Step 4**

#### **Recommended spare parts:**

Order Service Kits from Service kits list  
(See chapter 7 Parts list and service kits).

#### **Ordering spare parts**

Contact your local Alfa Laval sales company.

#### **Note:**

If the pump is supplied with FEP O-rings, Alfa Laval recommends that the casing O-ring is replaced during pump maintenance.

## 5 Maintenance

*Maintain the pump carefully. Study the instructions carefully and pay special attention to the warnings!  
Always keep spare shaft seals and rubber seals in stock.  
See separate motor instructions.*

### Safety check

A visual inspection of adaptor shield and motor fan guard must be carried out every 12 months. If loss or damage to shield or guard, especially when this leads to deterioration of safety performance, it shall be replaced.

The fixing of shield and guards should only be replaced with fixings of the same or an equivalent type.

### Inspection acceptance criteria:

- It is not possible to reach the shaft or fan
- The shield and guard must be securely mounted
- Ensure that the screws are tightened

### Procedure in case of non-acceptance:

- Fix and/or replace the shield or guard.

	Shaft seal	Rubber seals	Motor bearings
Preventive maintenance	<b>Replace after 12 months:</b> (one-shift) - Stationary and rotating seal ring - Quad-/O-rings	Replace when replacing the shaft seal	
Maintenance after leakage (leakage normally starts slowly)	<b>Replace at the end of the day:</b> - Stationary and rotating seal ring - Quad-/O-rings	Replace when replacing the shaft seal	
Planned maintenance	<ul style="list-style-type: none"> <li>- Regular inspection for leakage and smooth operation</li> <li>- Keep a record of the pump</li> <li>- Use the statistics for planning of inspections</li> </ul> <b>Replace after leakage:</b> <ul style="list-style-type: none"> <li>- Stationary and rotating seal ring</li> <li>- Quad-/O-rings</li> </ul>	Replace when replacing the shaft seal	Yearly inspection is recommended <ul style="list-style-type: none"> <li>- Replace complete bearing if worn</li> <li>- Ensure that the bearing is axially locked (See motor instructions)</li> </ul>
Lubrication	<b>Before fitting</b> Lubricate the O-rings with silicone grease or silicone oil	<b>Before fitting</b> Silicone grease or silicone oil	See "Relubrication Intervals", section 6.2 Relubrication intervals on page 45

### Pre-use check

#### CAUTION!

Fit the electrical connections correctly if they have been removed from the motor during servicing. (See pre-use check in section 3 Installation).

*Maintain the pump carefully. Study the instructions carefully and pay special attention to the warnings!  
Always keep spare shaft seals and rubber seals in stock.  
See separate motor instructions.*

---

**Pay special attention to warnings!**

1. Start and stop the motor momentarily
  2. Ensure that the pump operates smoothly.
-

## 5 Maintenance

---

*Maintain the pump carefully. Study the instructions carefully and pay special attention to the warnings!  
Always keep spare shaft seals and rubber seals in stock.  
See separate motor instructions.*

---

### 5.2 Cleaning Procedure

---

#### **Cleaning Procedure for Soiled Impeller Screw Tapped Hole:**

**Warning:** Always follow the instructions in the safety data sheet for the cleaning agent.

1. Remove stub shaft (7) per section 4 of Service manual.
2. Submerge and soak Stub Shaft for 5 minutes in COP tank with 2% caustic wash
3. Scrub the blind tapped impeller screw hole vigorously by plunging a clean 1/2" diameter sanitary bristle pipe brush in and out of the hole for two minutes while submerged.
4. Soak Stub Shaft (7) in acid sanitizer for 5 minutes, then scrub blind tapped hole as described in step 3 above.
5. Rinse well with clean water and blow-dry blind tapped hole with clean air.
6. Swab test the inside of the tapped hole to determine cleanliness.
7. Should the swab test fail, repeat steps 2 thru 6 above until swab test is passed.

Should swab testing continue to fail, or time is of the essence, install a new (spare) Stub Shaft (7).

---

*Study the instructions carefully. The items refer to the parts list and service kits section.  
Handle scrap correctly.  
\* : Relates to the shaft seal.*

### 5.3 Dismantling of pump/shaft seals

#### Step 1

Remove the cap nuts (29), washer (30), pump cover (49) and O-ring (32).

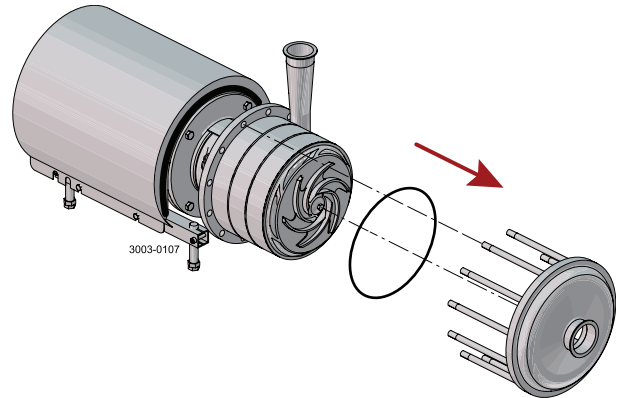

#### Step 2

##### Flushed shaft seal:

Unscrew tubes (25) using a spanner..

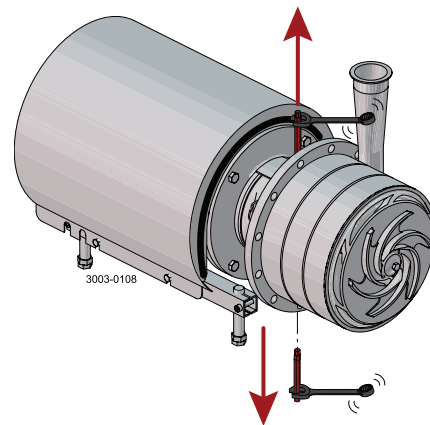

#### Step 3

Remove screw (16) and adaptor guard (17).

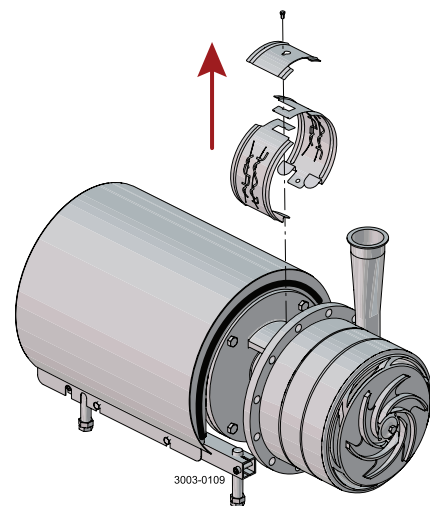

## 5 Maintenance

Study the instructions carefully. The items refer to the parts list and service kits section.  
Handle scrap correctly.

\* : Relates to the shaft seal.

### Step 4

Remove impeller screw (47) O-ring (41) and impeller (45).

\* Counterhold with a screwdriver!

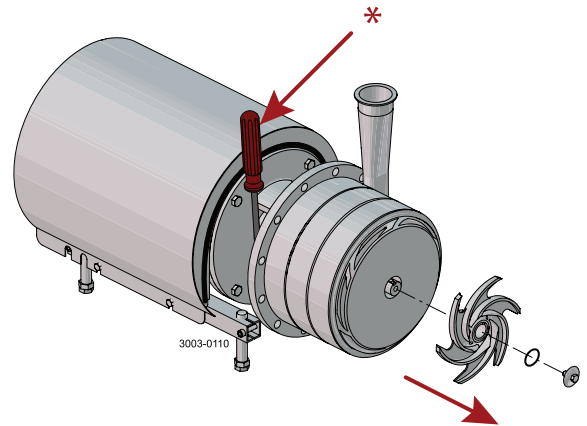

### Step 5

1. Remove intermediate casing (46) (3 or 4 stage) and/or pump casing (42).
2. Remove impeller (45) and O-rings (41) in between the stages.

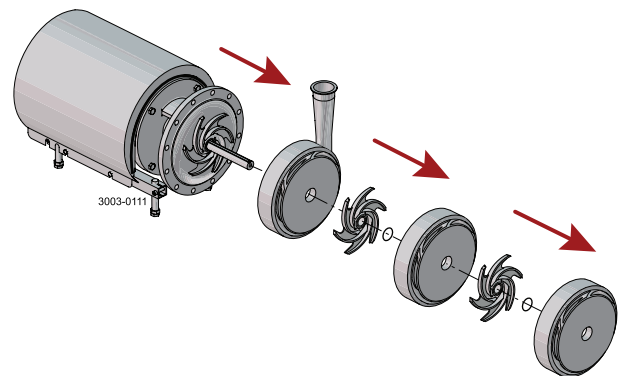

### Step 6

Remove guide vanes (44) and O-ring (43) from intermediate casing (3 or 4 stage) and /or pump casing (42).

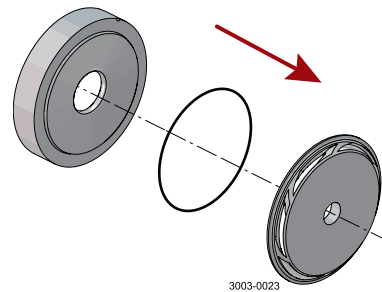

### Step 7

Remove impeller (40) and the rotating part of the shaft seal, and remove O-ring (41) from impeller.

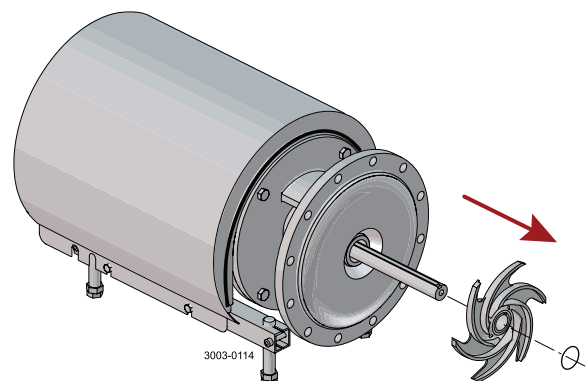

Study the instructions carefully. The items refer to the parts list and service kits section.  
 Handle scrap correctly.  
 \* : Relates to the shaft seal.

### Step 8

Remove space ring (35) and the rotating part of the seal from the impeller.

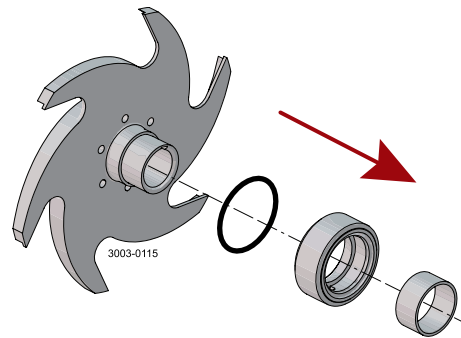

### Step 9

Remove rotating seal ring (36) the quad rings/O-rings (37, 39) and the supporting (38a) from rotating seal housing (38).

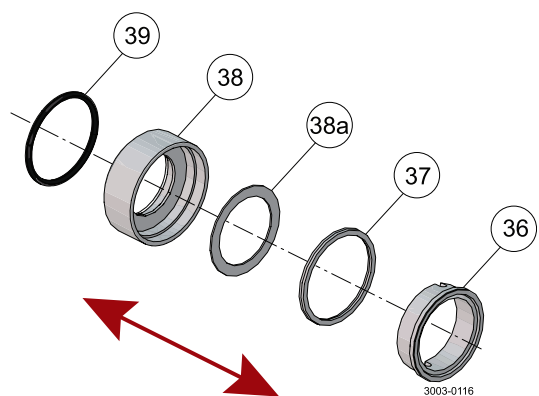

### Step 10

1. Remove the nuts (20), the washers (21) and back plate (31).
2. Remove O-ring (32) from the back plate.

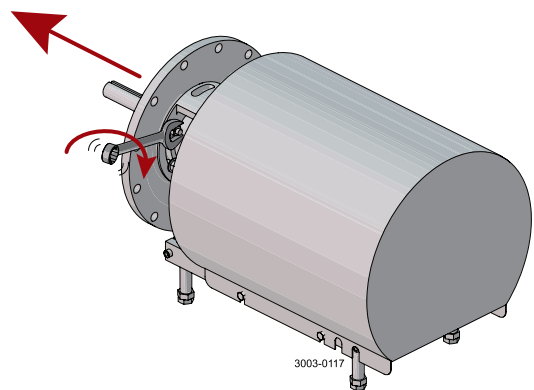

### Step 11

1. Remove stationary seal ring (34).
2. Remove O-ring (33) from the stationary seal ring.

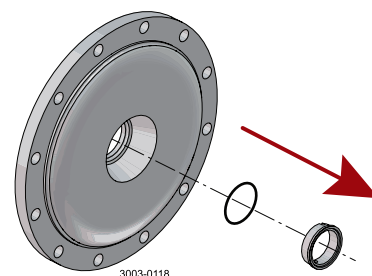

## 5 Maintenance

Study the instructions carefully. The items refer to the parts list and service kits section.  
Handle scrap correctly.

\* : Relates to the shaft seal.

### Step 12

#### Flushed shaft seal:

1. Remove the screws (24) and seal housing (26).
2. Remove lip seal (28) and O-ring (27) from the seal housing.
3. Remove seal ring (23) from stub shaft (11).
4. Remove O-ring (22) from the seal ring.

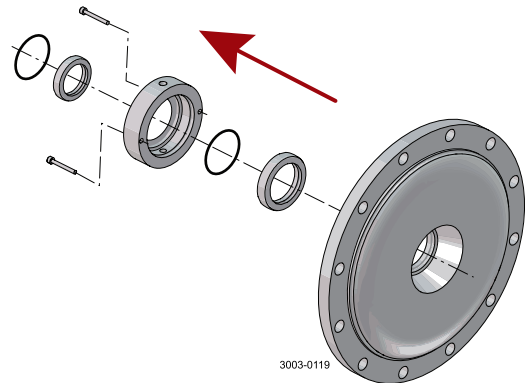

### Step 13

1. Remove scroud (2).
2. Remove nuts (7), washers (8), screws (19) and adaptor (18).

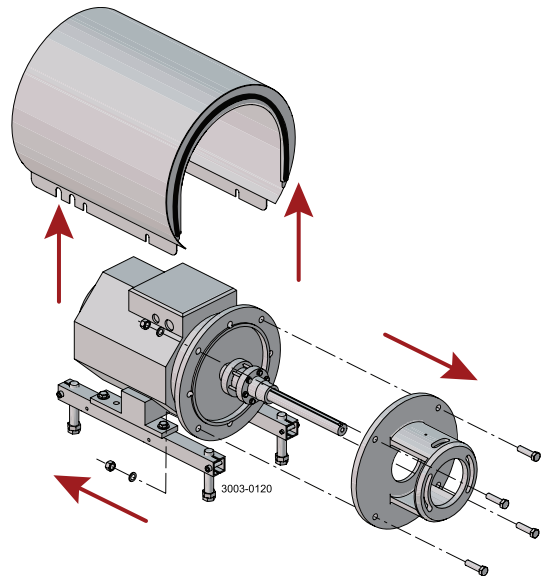

### Step 14

1. Loosen the screws (15).
2. Remove stub shaft (11) and the compression rings (9,13).

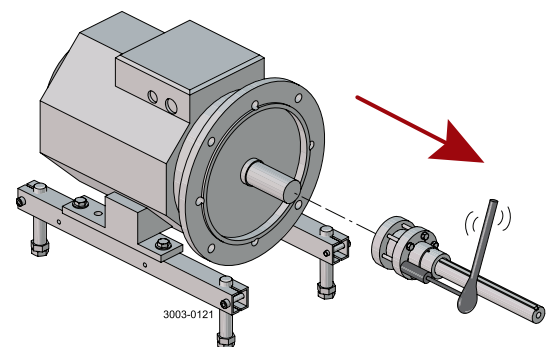

### Step 15

Remove the screws (15), washers (15a) and the compression rings (9,13).

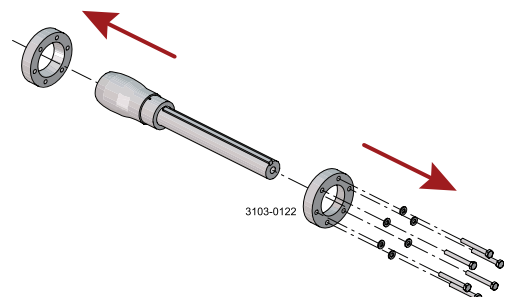



Study the instructions carefully. The items refer to the parts list and service kits section.  
Handle scrap correctly.

\* : Relates to the shaft seal.

### 5.4 Assembly of Pump/Assembly of Shaft Seal – LKH-110

#### Step 1

1. Fit the compression rings (9,13), washers (15a) and the screws (15) on stub shaft (11).
2. Fit the stub shaft on the motor shaft.
3. Check the clearance between the end of the stub shaft and the motor flange.

\* 10–20 mm  
(0.394–0.787 inch)

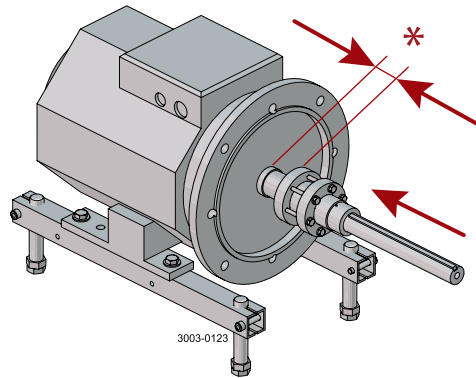

#### Step 2

1. Tighten the screws (15) evenly.
2. Ensure that stub shaft (11) can be moved on the motor shaft.

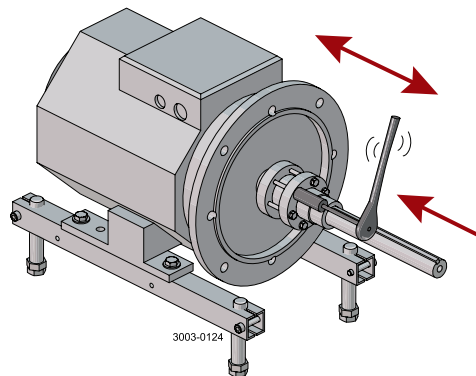

#### Step 3

Fit adaptor (18), screws (19), washers (8) and nuts (7).

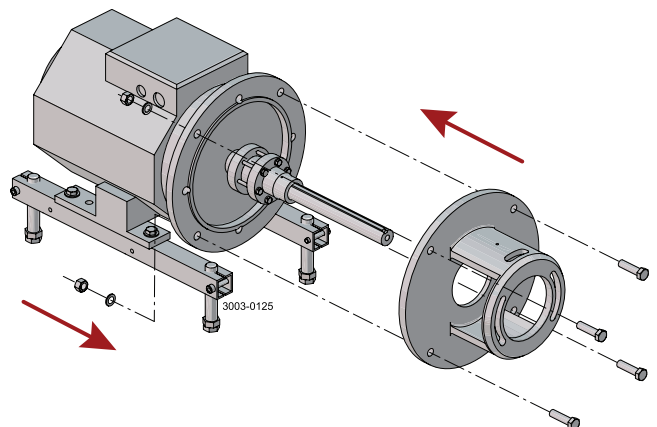

## 5 Maintenance

Study the instructions carefully. The items refer to the parts list and service kits section.  
Handle scrap correctly.

\* : Relates to the shaft seal.

### Step 4

Fit back plate (31), washers (21) and nuts (20).

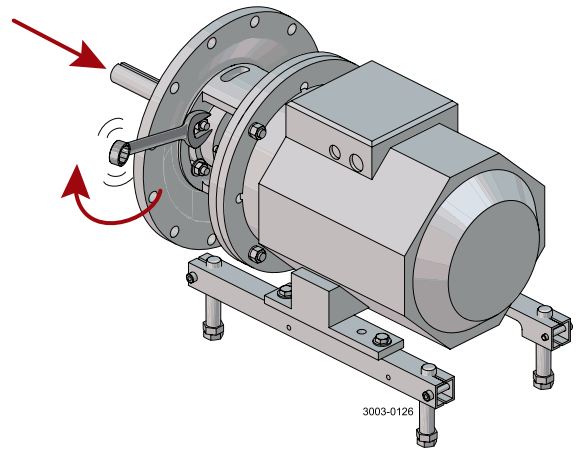

### Step 5

1. Assemble the rotating part of the shaft seal.
2. Fit the seal part and the space ring on impeller (40).

#### CAUTION!

Ensure that the driver in the rotating seal housing enters the notch in the rotating seal ring.

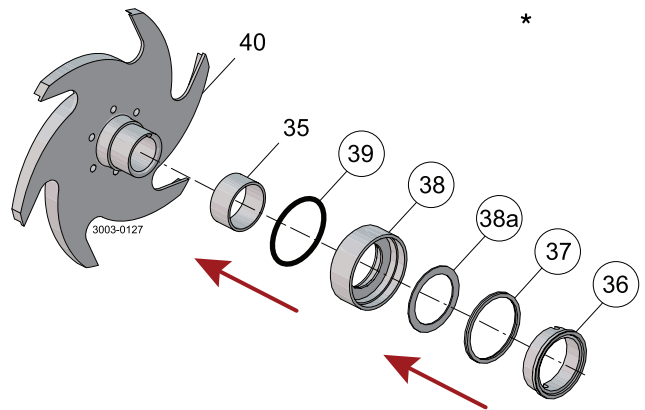

### Step 6

1. Fit impeller (40,45) on stub shaft (11). Fit and tighten impeller screw (47).
2. Ensure that the clearance between impeller (40) and back plate (31) is 1mm (0.0394 inch).

\* 1 mm

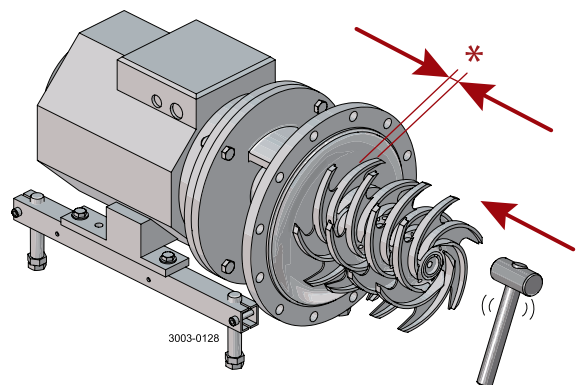

Study the instructions carefully. The items refer to the parts list and service kits section.  
Handle scrap correctly.

\* : Relates to the shaft seal.

### Step 7

1. Remove impeller screw (47) and remove impeller (40,45) and back plate (31).
2. Tighten the screws (15) evenly to 15Nm. (11 lbf-ft)

\* 15 Nm (11 lbf-ft)

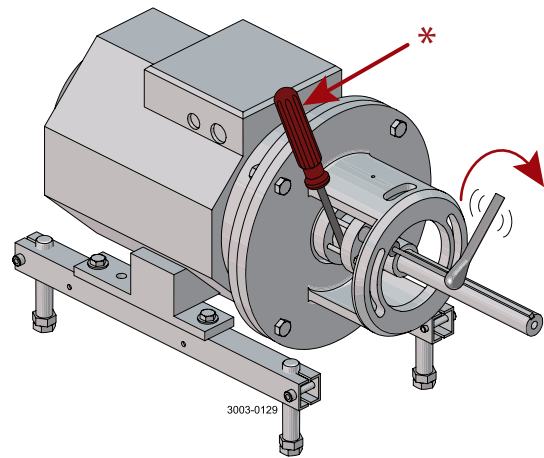

### Step 8

1. Fit O-ring (33) on stationary seal ring (34).
2. Press the stationary seal ring in back plate (31).

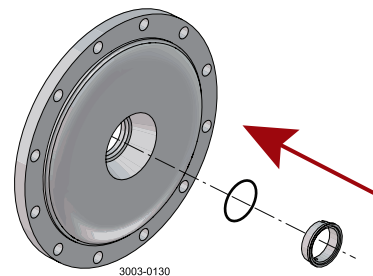

### Step 9

#### Flushed shaft seal:

1. Fit lip seal (28) in seal housing (26).
2. Fit O-ring (27) in the seal housing.
3. Fit the housing on back plate (31) and tighten the screws (24).

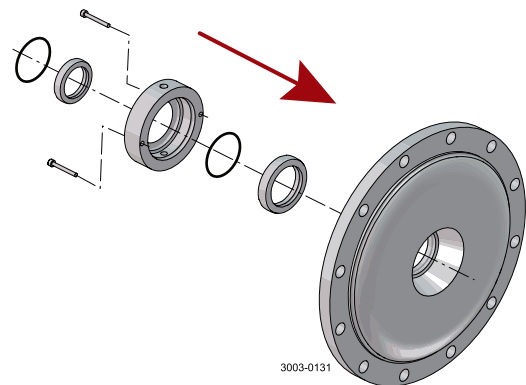

### Step 10

1. Fit back plate (31), washers (21) and nuts (20).
2. Fit O-ring (41) in impeller. Fit impeller (40) with shaft seal parts and space ring on shaft (11).
3. Fit O-ring (32) on the back plate.

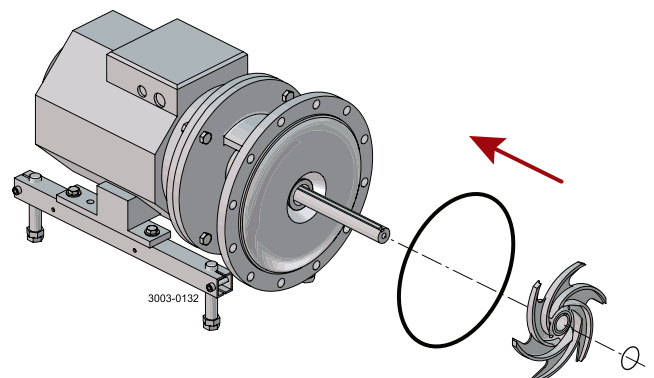

## 5 Maintenance

Study the instructions carefully. The items refer to the parts list and service kits section.  
Handle scrap correctly.

\* : Relates to the shaft seal.

### Step 11

LKH-112:

1. Fit pump casing (42) on back plate (31).
2. Fit O-ring (43) on casing. Fit guide vanes (44).
3. Fit O-ring (32) on guide vanes (44).
4. Go to Step 14

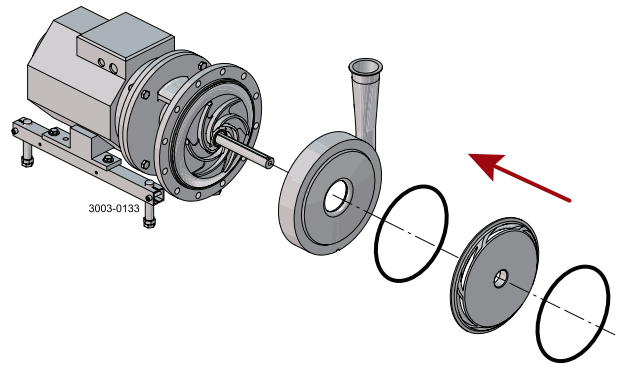

### Step 12

LKH-113:

1. Fit O-ring (41) in impeller (45). Fit impeller (45) on shaft (11).
2. Fit intermediate casing (46).
3. Fit O-ring (43) on intermediate casing (46). Fit guide vane (44).
4. Fit O-ring (32) on guide vanes (44).
5. Go to Step 14

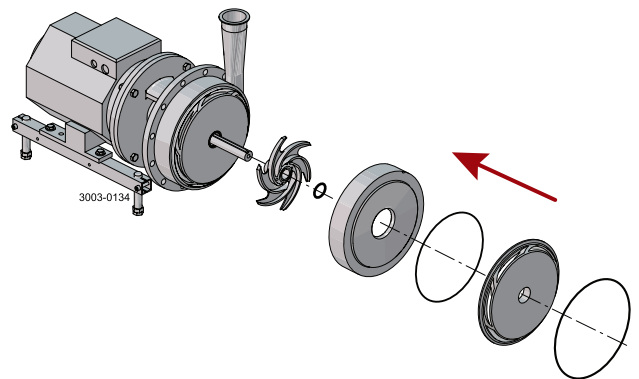

### Step 13

LKH-114:

1. Fit O-ring (41) in impeller (45). Fit impeller (45) on shaft (11).
2. Fit intermediate casing (46).
3. Fit O-ring (43) on intermediate casing (46). Fit guide vane (44).
4. Fit O-ring (32) on guide vanes (44).

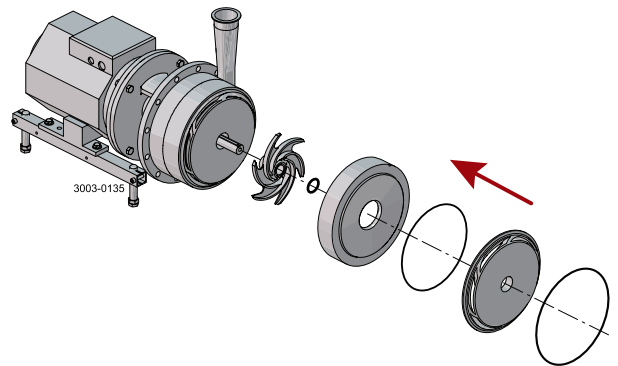

### Step 14

1. Fit impeller (45) and O-ring (41) .
2. Fit and tighten impeller screw (47).

\* Counterhold with a screwdriver!

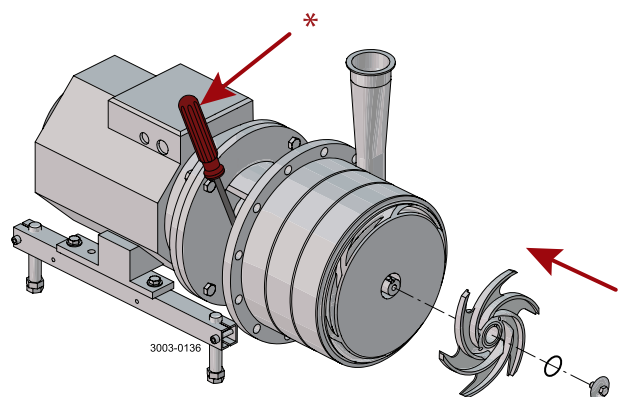

Study the instructions carefully. The items refer to the parts list and service kits section.  
Handle scrap correctly.

\* : Relates to the shaft seal.

### Step 15

1. Fit O-ring (32) and pump cover (49).
2. Fit washers (30) and cap nuts (29).
3. Tighten four cap nuts in following order. First 12 o'clock then 3, 9 o'clock and finally 6 o'clock. The rest to follow in random order. Torque values from Technical data section 6.3 are to be used.
4. **NOTE! Tighten impeller screw with a socket wrench through the inlet.**
5. **NOTE! Rotate the pump shaft by hand and insure the impellers runs smoothly without touching.**

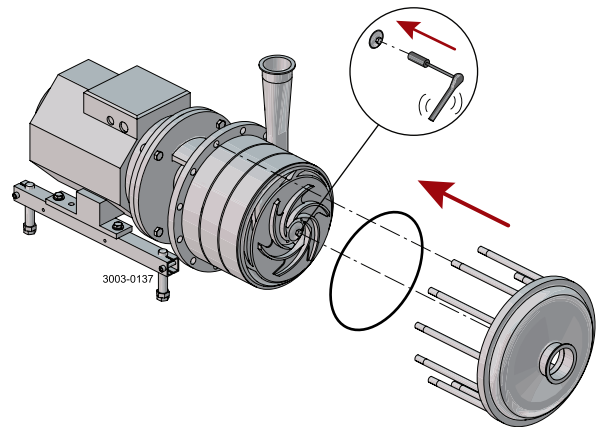

### Step 16

1. Fit shroud (2).
  2. Fit safety guard (17) and screw (16).
- If pump is not supplied with flush connections the holes in the adaptor shall be covered by the guard.

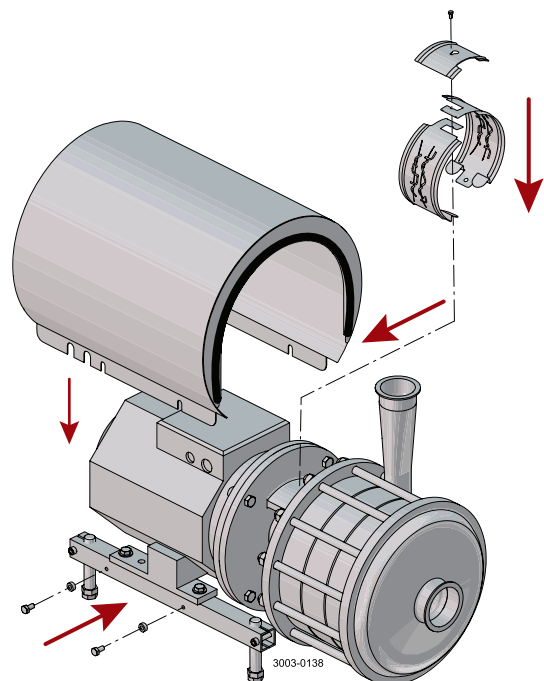

### Step 17

#### Flushed shaft seal:

Fit the tubes (25) on seal housing (26).

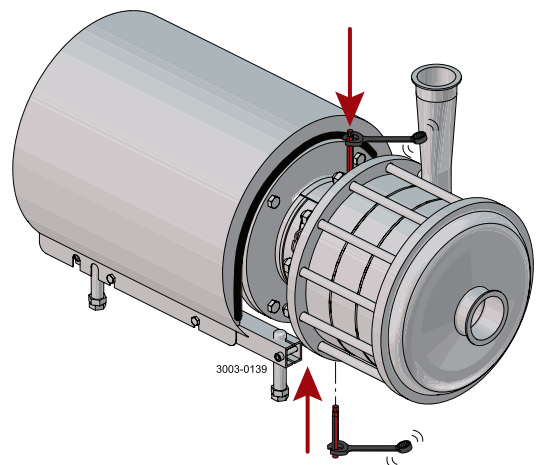

## 5 Maintenance

Study the instructions carefully. The items refer to the parts list and service kits section.  
Lubricate the rubber seals before fitting them.  
\* : Relates to the shaft seal.

### 5.5 Assembly of Pump/Assembly of Shaft Seal – LKH-120/P

#### Step 1

1. Fit the compression rings (9,13) and the screws (15) on stub shaft (11).
2. Fit the stub shaft on the motor shaft.
3. Check the clearance between the end of the stub shaft and the motor flange.

\* 10–20 mm  
(0,394–0,787 inch)

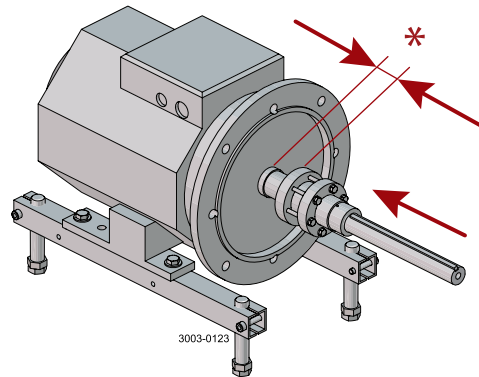

#### Step 2

1. Tighten the screws (15) evenly.
2. Ensure that stub shaft (11) can be moved on the motor shaft.

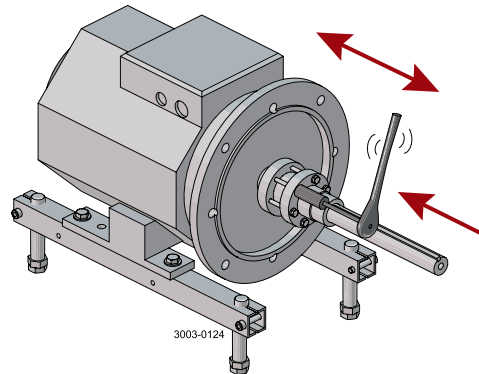

#### Step 3

- Fit adaptor (18), screws (19), washers (8) and nuts (7).

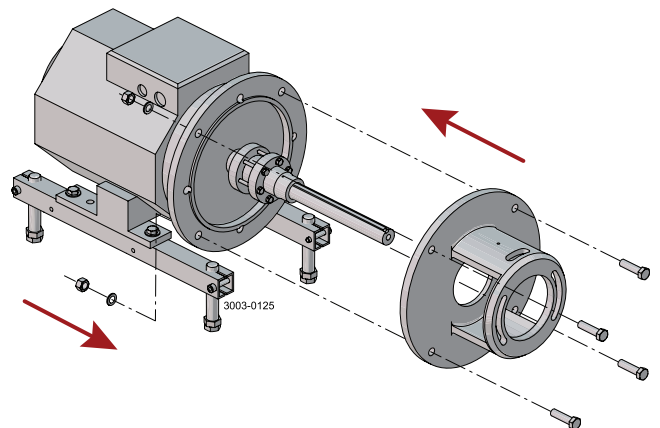

#### Step 4

1. Fit O-ring (37) on stationary seal ring (34).
2. Press the stationary seal ring in back plate (31).

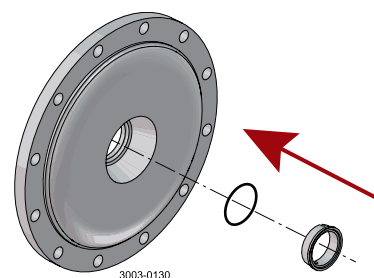

Study the instructions carefully. The items refer to the parts list and service kits section.  
Lubricate the rubber seals before fitting them.  
\* : Relates to the shaft seal.

### Step 5

#### Flushed shaft seal:

1. Fit lip seal (28) in seal housing (26).
2. Fit O-ring (27) in the seal housing.
3. Fit the housing on back plate (31) and tighten the screws (24).
4. Fit seal ring (23) with O-ring (22) on stub shaft (11).

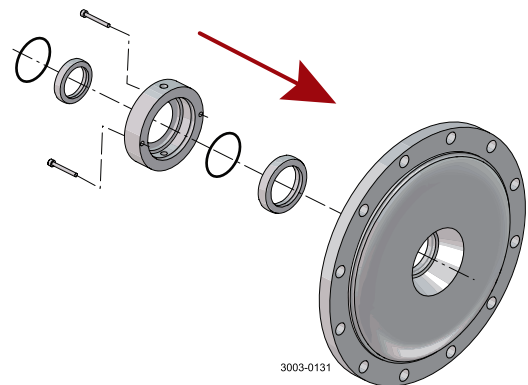

### Step 6

Fit back plate (31), washers (21) and nuts (20).

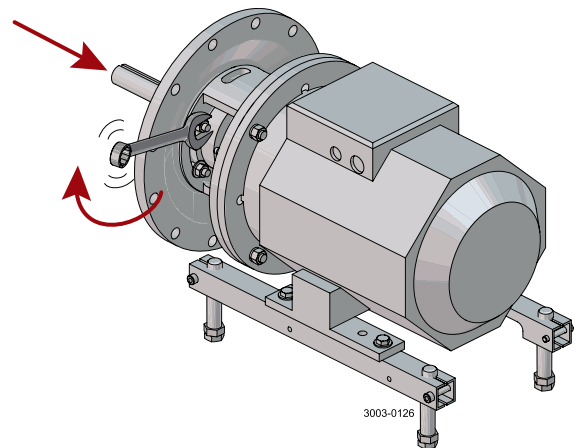

### Step 7

1. Assemble the rotating part of the shaft seal.
2. Fit the seal part and the space ring on impeller (40).

#### CAUTION!

Ensure that the driver in the rotating seal housing enters the notch in the rotating seal ring.

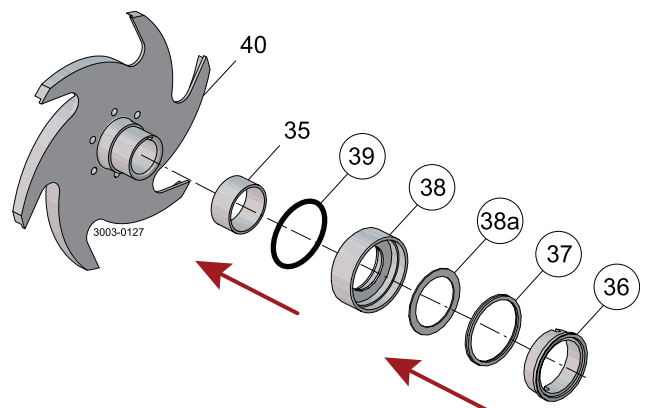

## 5 Maintenance

*Study the instructions carefully. The items refer to the parts list and service kits section.  
Lubricate the rubber seals before fitting them.  
\* : Relates to the shaft seal.*

### Step 8

1. Fit back plate (31), washers (21) and nuts (20).
2. Fit O-ring (41) in impeller. Fit impeller (40) with shaft seal parts and space ring on shaft (11).
3. Fit O-ring (32) on the back plate.

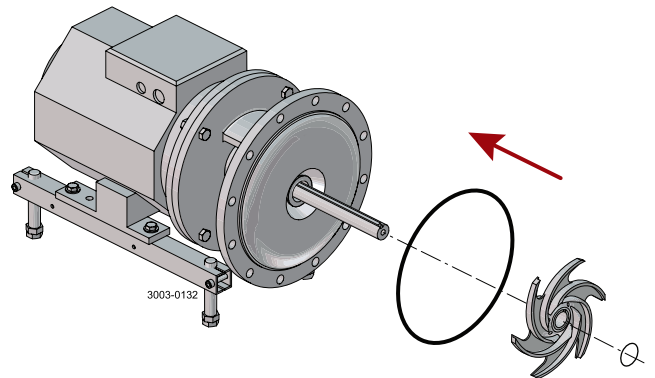

### Step 9

LKH-122/P:

1. Fit pump casing (42) on back plate (31).
2. Fit O-ring (43) on casing. Fit guide vanes (44).
3. Fit O-ring (32) on guide vanes (44).
4. Go to Step 12

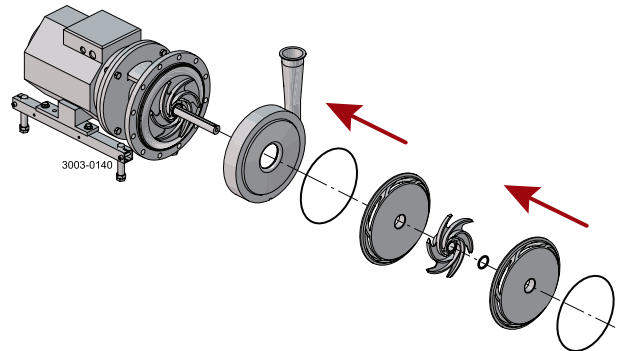

### Step 10

LKH-123/P:

1. Fit O-ring (41) in impeller (45). Fit impeller (45) on shaft (11).
2. Fit intermedia casing (46).
3. Fit O-ring (43) on intermediate casing (46). Fit guide vane (44).
4. Fit O-ring (32) on guide vanes (44).
5. Go to Step 12

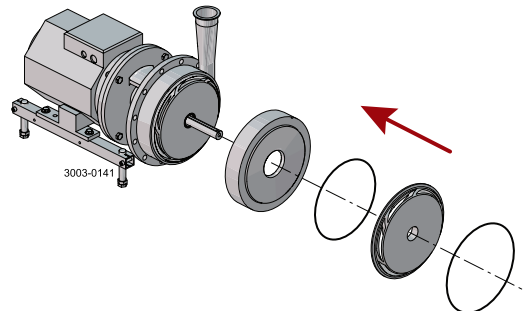

### Step 11

LKH-124/P:

1. Fit O-ring (41) in impeller (45). Fit impeller (45) on shaft (11).
2. Fit intermediate casing (46).
3. Fit O-ring (43) on intermediate casing (46). Fit guide vane (44).
4. Fit O-ring (32) on guide vanes (44).

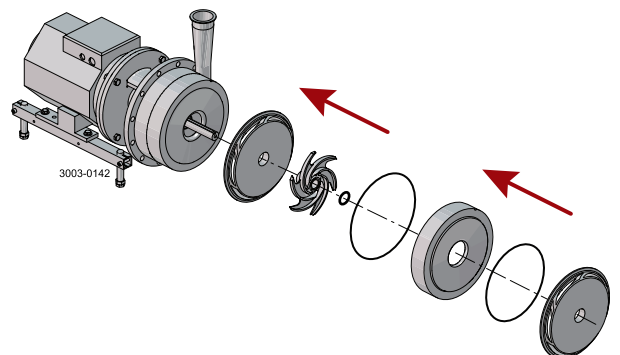



Study the instructions carefully. The items refer to the parts list and service kits section.  
Lubricate the rubber seals before fitting them.  
\* : Relates to the shaft seal.

### Step 12

1. Fit impeller (45) and O-ring (41).
2. Fit and tighten impeller screw lightly (47).

\* Counterhold with a screwdriver!

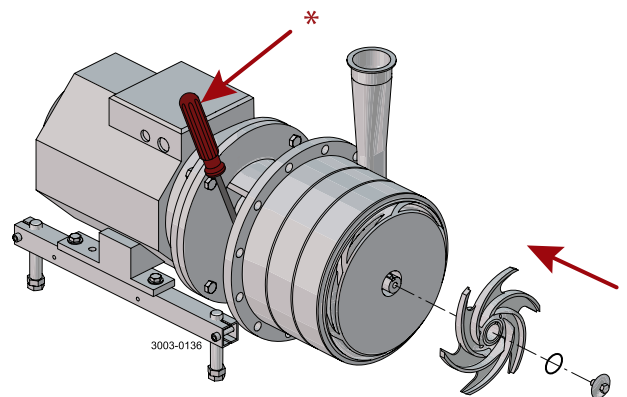

### Step 13

1. Fit O-ring (32) and pump cover (49).
2. Fit the washers (30) and the cap nuts (29).
3. Tighten four cap nuts in following order. First 12 o'clock then 3, 9 o'clock and finally 6 o'clock. The rest to follow in random order. Torque values from Technical data section 6.3 are to be used.
4. **NOTE! Tighten impeller screw (47) with a socket wrench through the inlet.**

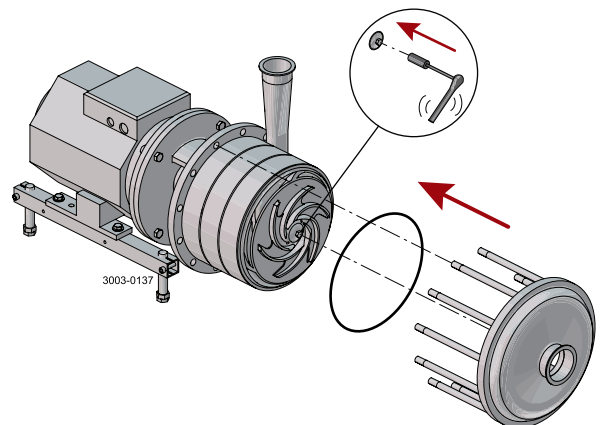

### Step 14

1. Push the shaft completely forward until the impeller touches the cover and zero set the dial gauge.
2. Push back the shaft 0.6 mm (0.0236 inch).
3. Tighten the screws in the compression coupling with 18 Nm (13.3 lbf-ft).
4. **NOTE! Rotate the pump shaft by hand and insure the impellers runs smoothly without touching.**

**Note:** Special tool for dial gauge is optional (9612927801)

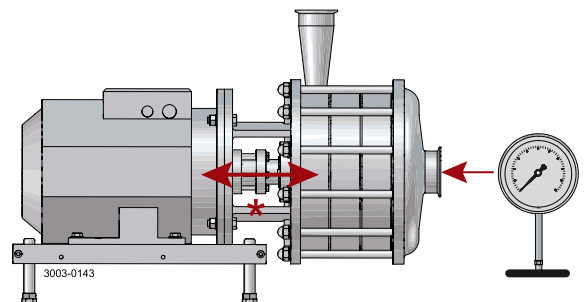

\* Torque 18 Nm (13.3 lbf-ft)

## 5 Maintenance

---

*Study the instructions carefully. The items refer to the parts list and service kits section.  
Lubricate the rubber seals before fitting them.  
\* : Relates to the shaft seal.*

---

### Step 15

1. Fit shroud (2).
2. Fit safety guard (17) and screw (16).

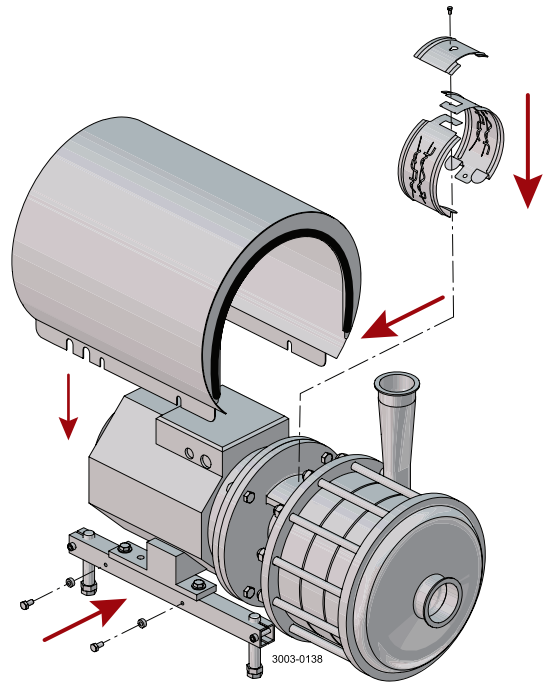

### Step 16

#### Flushed shaft seal:

Fit the tubes (25) on seal housing (26).  
If pump is not supplied with flush connections the holes in the adaptor shall be covered by the guard.

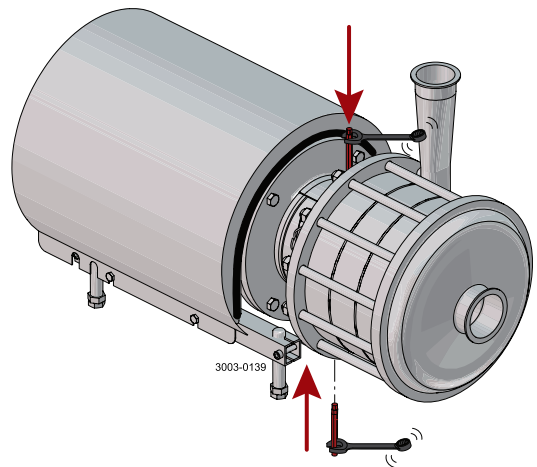

*It is important to observe the technical data during installation, operation and maintenance.  
Inform possible personnel about the technical data.*

## 6.1 Technical data

The LKH-110 and -120P pump is highly efficient and economical centrifugal pump, which meets the requirements of sanitary and gently product treatment and chemical resistance. LKH-110 and the LKH-120P is available in the following sizes, LKH-112, -113, -114 and LKH122/P, -123/P, -124/P. The instruction manual is part of the delivery. Study the instructions carefully. The large pump sizes are very heavy. Alfa Laval therefore recommends the use of a lifting crane when handling the pump.

**>40°C**

**Max inlet pressure**

Pump size	Speed and shaft seal material			
	C/SiC	Max 50Hz	SiC/SiC	Max 60Hz
	Max inlet pressure (bar)			
LKH-112	10	10	10	10
LKH-113	10	10	10	10
LKH-114	10	10	10	10
LKH-112/P	N/A	20	N/A	15
LKH-113/P	N/A	20	N/A	20
LKH-114/P	N/A	20	N/A	20
LKH-122/P	10	30	N/A	30
LKH-123/P	10	30	N/A	30
LKH-124/P	N/A	25	N/A	20

**<40°C**

**Max inlet pressure**

Pump size	Speed and shaft seal material			
	C/SiC	Max 50Hz	SiC/SiC	Max 60Hz
	Max inlet pressure (bar)			
LKH-112	10	10	10	10
LKH-113	10	10	10	10
LKH-114	10	10	10	10
LKH-112/P	N/A	30	N/A	30
LKH-113/P	N/A	30	N/A	30
LKH-114/P	N/A	25	N/A	25
LKH-122/P	10	30	N/A	30
LKH-123/P	10	30	N/A	30
LKH-124/P	N/A	25	N/A	20

Data						
Speed	Max. inlet pressure:				Motor	Backplate
	Max 50Hz		Max 60Hz			
Shaft seal material	C/SiC	SiC/SiC	C/SiC	SiC/SiC		
Pump size						
LKH-112	10	10	10	10	Std	Std
LKH-113	10	10	10	10	Std	Std
LKH-114	10	10	10	10	Std	Std
LKH-112/P	N/A	30	N/A	30	Special	Reinforced
LKH-113/P	N/A	30	N/A	30	Special	Reinforced
LKH-114/P	N/A	25	N/A	25	Special	Reinforced
LKH-122/P	10	30	N/A	30	Special	Std
LKH-123/P	10	30	N/A	30	Special	Std
LKH-124/P	N/A	25	N/A	20	Special	Std

## 6 Technical data

*It is important to observe the technical data during installation, operation and maintenance.  
Inform possible personnel about the technical data.*

<b>Data</b>			
Temperature range	-10°C to +140°C	(EPDM)	(14°F to 284°F)
Noise level	60-80 dB(A)		
Max. speed	3600 rpm		
<b>Materials</b>			
Product wetted steel parts	AISI 316L and Duplex steel		
Other steel parts	Stainless steel		
Product wetted seals	EPDM (standard)		
Other O-rings	EPDM		
Alternative seals	Nitrile (NBR), Fluorinated rubber (FPM)		
Finish	Standard Blasted		
<b>Shaft seal</b>			
Seal types	Single internal or flushed seal		
Max. temperature flush media	70°C		
Max. water pressure (flushed seal)	Normal atmosphere	(max. 1 bar)	(14.5 psi)
Water consumption (flushed seal)	0.25 - 0.5 l/min.	(0.07-0.13 gal/min)	
Material, stationary seal ring	Silicon carbide		
Material, rotating seal ring	Carbon or silicon carbide		
Material, Quad-/O-rings	EPDM (standard)		
<b>Motor</b>			
Foot-flanged motor acc. to IEC metric standard 2 poles = 3000/3600 rpm. at 50/60 Hz IP55 (drain hole with labyrinth plug), insulation class F			
Motor types:	<ul style="list-style-type: none"> <li>- Standard motor with a fixed ball bearing on drive side</li> <li>- Special motor with fixed special bearings</li> </ul>		
<b>NOTE:</b> Special motor must be ordered if required.			

**Relubrication interval 50 Hz (3000 rpm)/Relubrication interval 60 Hz (3600 rpm).** (Vendor) quantity in Drive End/quantity in Non Drive End.

## 6.2 Relubrication intervals

For recommended grease types and general maintenance follow the recommendations in the motor instruction manual.

For relubrication intervals see motor name plate.

For further information contact your local Alfa Laval Technical Support.

**Warning: Polyurea based (used on e.g LKH85 motors) must not be mixed with Lithium based grease or vice versa.**

## 6.3 Torque Specifications

Below table specifies the tightening torques for the screws, bolts and nuts in this pump.

Always use below torques if no other values are stated. This can be a matter of personal safety.

Size	Tightening torque	
	Nm	lbf-ft
M8	20	14.8
M10	40	29.5
M12	67	49.0
M14	110	81.0

## 6 Technical data

*Relubrication interval 50 Hz (3000 rpm)/Relubrication interval 60 Hz (3600 rpm). (Vendor) quantity in Drive End/quantity in Non Drive End.*

### 6.4 Weight (kg)

#### Pump Type: LKH-110

Size	90 1.5kW	100 3kW	112 4kW	132		160		
				5.5kW	7.5kW	11kW	15kW	18.5kW
112	63	77	83	99	114	155	166	220
113		80	56	118	118	158	169	223
114				121	121	163	174	228

Weight can vary depending of configuration. Weight is only to be seen as a reference value during handling, transporting and packaging.

#### Pump Type: LKH-120

Size	180 22kW	30kW	200 37kW	45kW	250	
					55kW	75kW
122	247	330	370	374		
123	277	350	390	394	510	545
124		367	407	411	527	562

Weight can vary depending of configuration. Weight is only to be seen as a reference value during handling, transporting and packaging.

*Relubrication interval 50 Hz (3000 rpm)/Relubrication interval 60 Hz (3600 rpm). (Vendor) quantity in Drive End/quantity in Non Drive End.*

## 6.5 Noise emission

Pump Type	Sound pressure level (dBA)
LKH-5	60
LKH-10	69
LKH-15	72
LKH-20	70
LKH-25	74
LKH-35	71
LKH-40	75
LKH-45	70
LKH-50	75
LKH-60	77
LKH-70	88
LKH-75	79
LKH-85	86
LKH-90	75
LKH-112	70
LKH-113	69
LKH-114	68
LKH-122	75
LKH-123	77
LKH-124	80
SolidC-1	68
SolidC-2	72
SolidC-3	73
SolidC-4	72
MR-166	76
MR-185	82
MR-200	81
MR-300	82
GM	54
FM-OS	61

The above LKH noise levels are the same for LKH PF, LKHI, LKH UltraPure, LKH Evap, LKHex.  
The above SolidC noise levels are the same for SolidC UltraPure.

The noise measurements have been carried out with original motor and shroud, approximately at the Best Efficiency Point (BEP) with water at ambient temperature and at 50 Hz.

Very often the noise level generated by the flow through the process system (eg. valves, pipes, tanks etc.) is much higher than what is generated by the pump itself. Therefore it is important to consider the noise level from the total system and take the necessary precautions with regards to personal safety if required.

## 7 Parts list and service kits

**Relubrication interval 50 Hz (3000 rpm)/Relubrication interval 60 Hz (3600 rpm).** (Vendor) quantity in Drive End/quantity in Non Drive End.

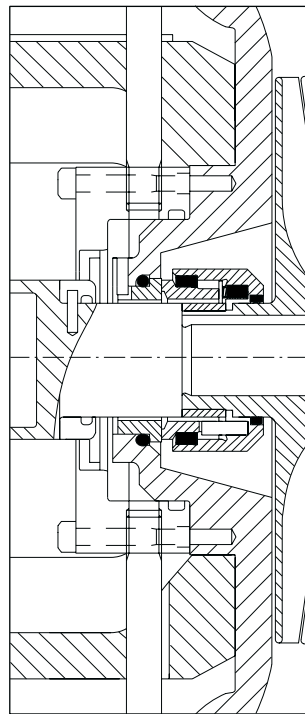
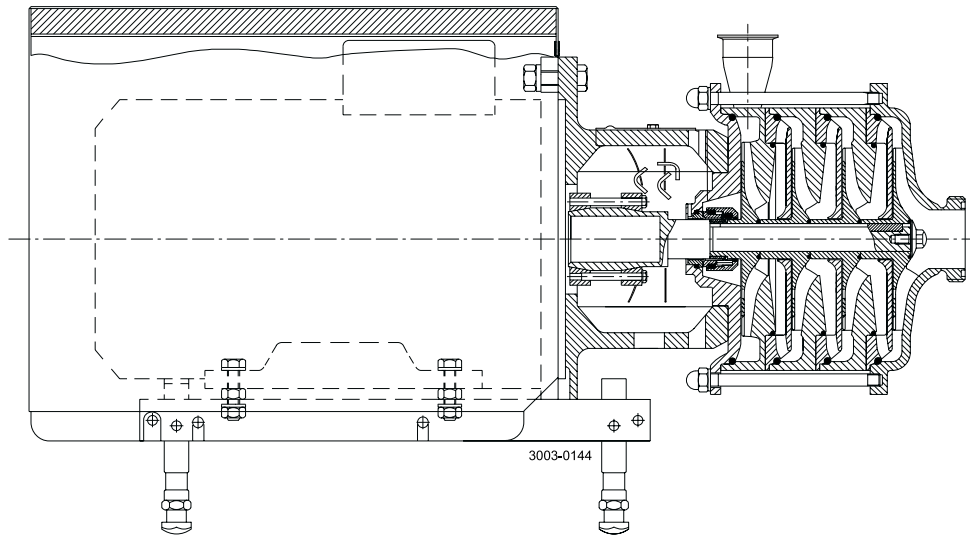

3003-0051





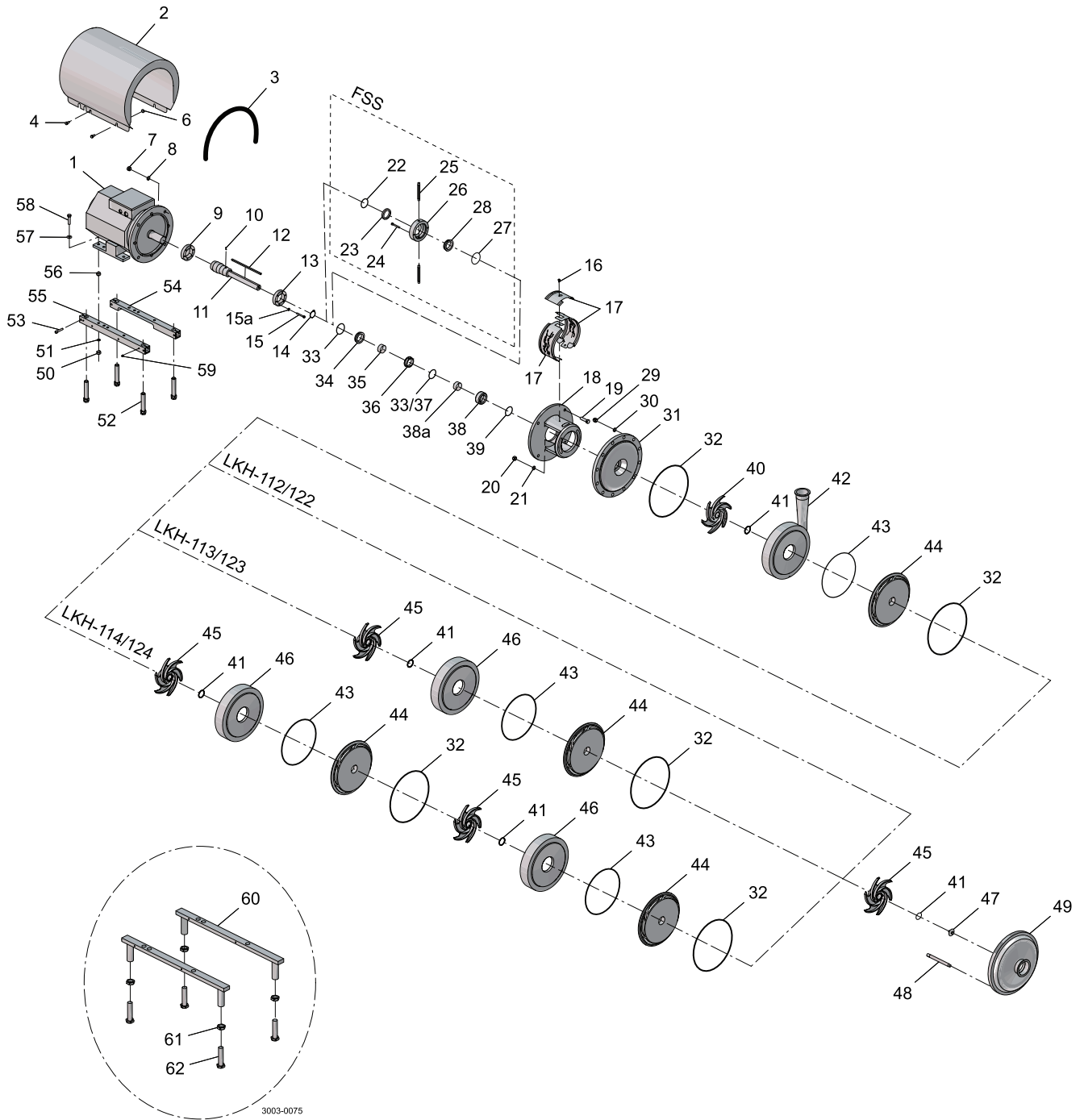





7.2 LKH Multi-Stage - Wet end



## 7 Parts list and service kits

---

### Parts list

Pos.	Qty	Denomination
12	1	Key
20	2	Nut
21	2	Washer
29	6	Cap nut
30	6	Washer
31	1	Back plate std. blasted
32    	2	O-ring
40	1	Impeller back std. blasted
41	2	O-ring
42		Pump casing
43    	1	O-ring
44	1	Guide vanes blasted
45	1	Impeller std. blasted
46	1	Intermediate casing blasted
47	1	Impeller screw std. Blasted
48	6	Bolt
49		Pump Cover
63	1	Set of 8 springs for rotating sealhousing

---

7.3 LKH Multi-Stage – Motor dependent parts

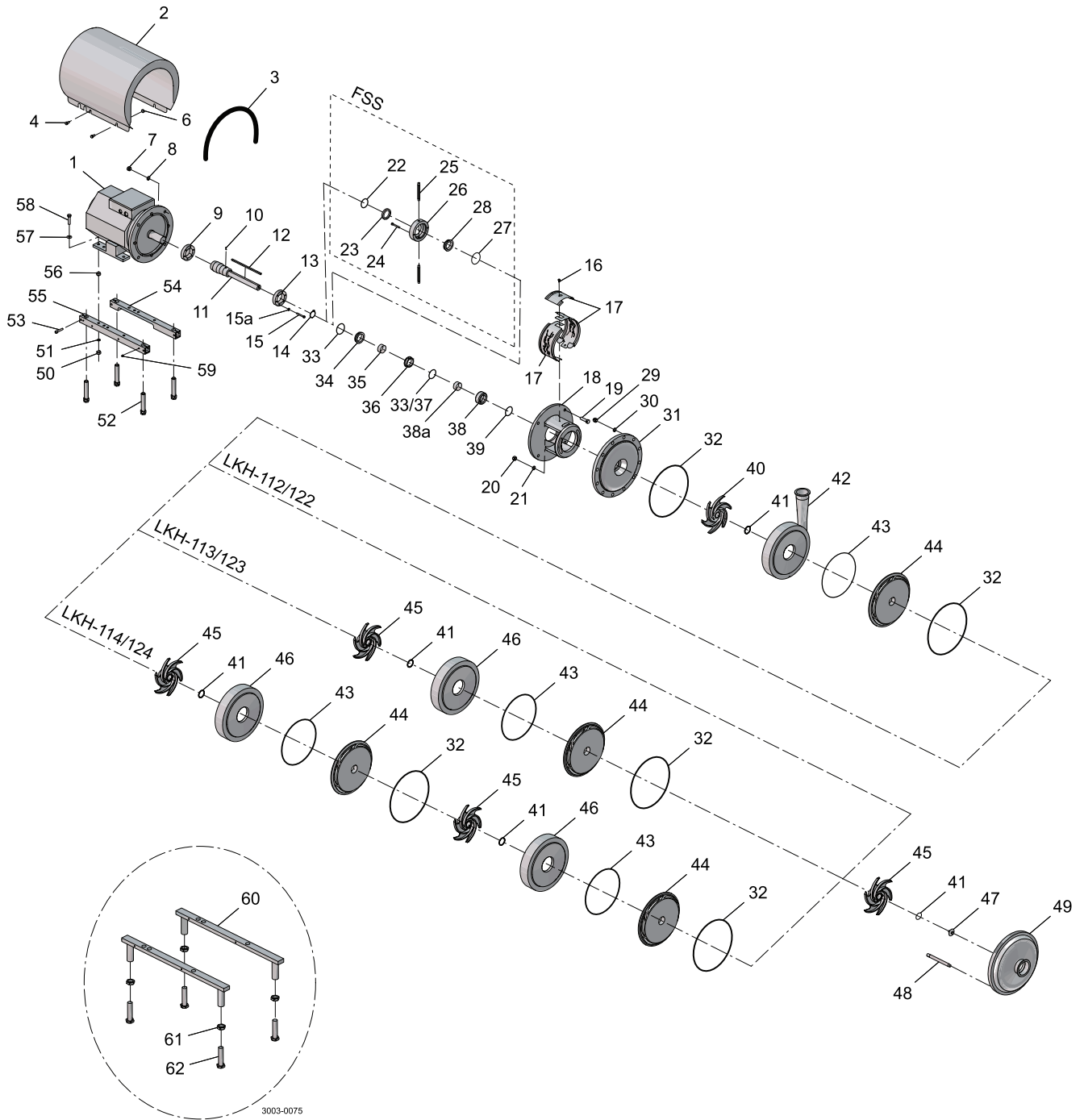

## 7 Parts list and service kits

---

### Parts list

Pos.	Qty	Denomination
1	1	Motor ABB 3000rpm
2	1	Shroud
3	1	Edge list
4	4	Screw
6	4	Distance sleeve
7	4	Nut for adaptor
8	1	Connex pin
9	1	Compression ring
10	1	Connex pin
11	1	Shaft
13	1	Compression ring
14	1	Retaining ring
15	6	Screw
15a	6	Washer
16	1	Screw
17	1	Safety guard set
18	1	Adaptor
19	4	Screw for adaptor
50	4	Nut
51	4	Spring washer
52	4	Leg
53	4	Screw
54	1	Support bar
55	1	Support bar
56	4	Nut
57	4	Washer
58	4	Screw
59	4	Pivot screw
60	2	Leg bracket
61	4	Nut for leg
62	4	Screw for leg

---

7.4 LKH Multi-Stage – Shaft seal and Service kits

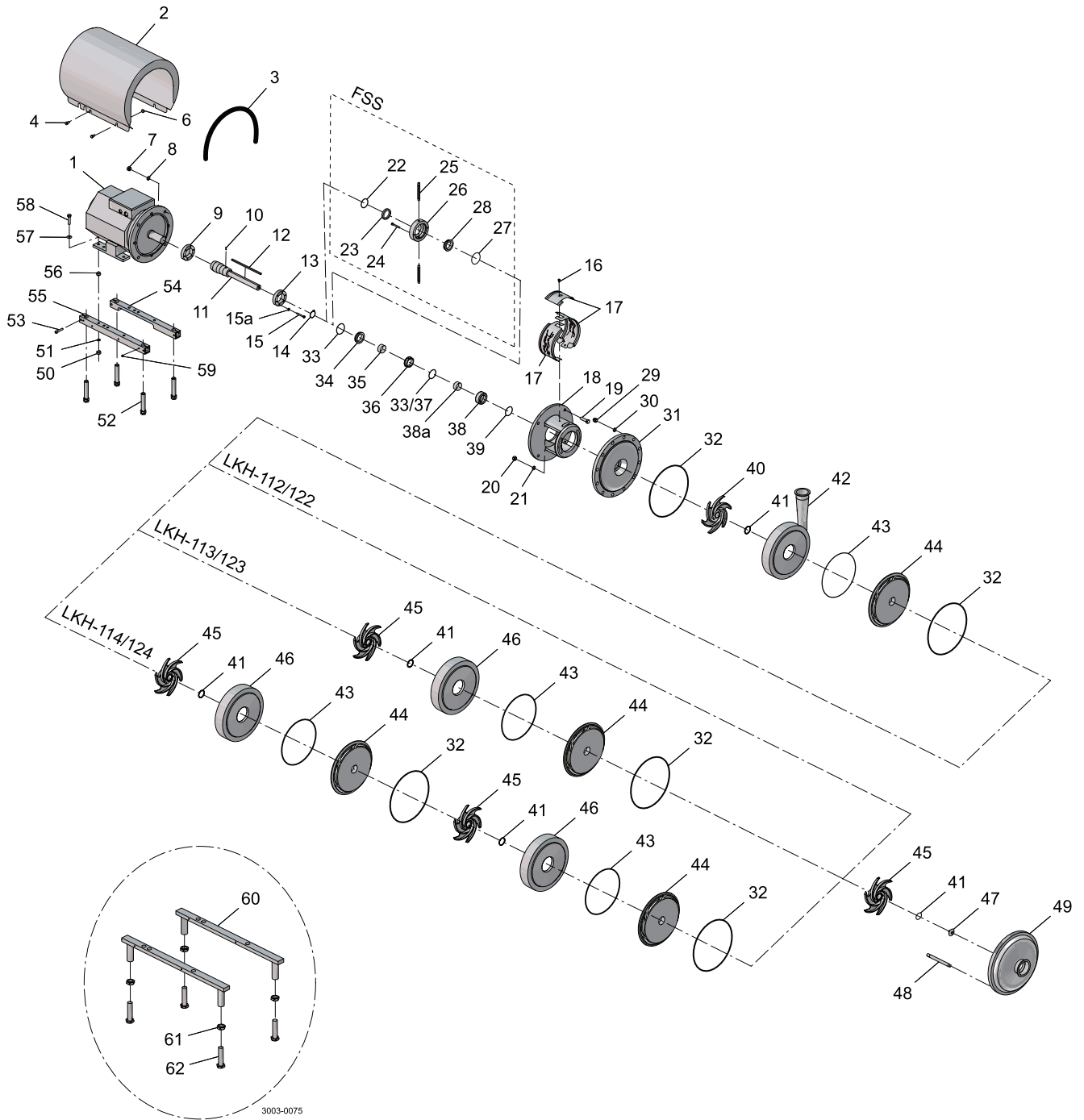

## 7 Parts list and service kits

### Parts list

Pos.	Qty	Denomination
□○		Shaft seal complete
◆■		Shaft seal complete
□○		Shaft seal complete
◆■		Shaft seal complete
22	1	O-ring
23	1	Sleeve
24	2	Screw
25	2	Tube
26	1	Seal housing
27	1	O-ring
28	1	Lip seal
33	1	O-ring
	1	O-ring
	1	O-ring (EPDM)
34	1	Stationary seal ring
	1	Stationary seal ring
35	1	Spacing ring
36	1	Rotating seal ring
	1	Rotating seal ring
37	1	Quad ring
	1	Quad ring
38	1	Rotating seal housing
38a	1	Support ring
	1	Support ring
39	1	Quad ring
	1	Quad ring
60	1	Set of 8 springs for rotating sealhousing (incl. In pos 38)

### Service kits

Denomination	EPDM	NBR
<b>Service kit for single shaft seal C/SIC</b>		
□ Service kit C/SIC LKH-112/ LKH-112P .....	9611922096	9611922097
Service kit C/SIC LKH-113/ LKH-113P .....	9611922102	9611922103
Service kit C/SIC LKH-114/ LKH-114P .....	9611922108	9611922109
Service kit C/SIC LKH-122 .....	9611922409	9611922410
Service kit C/SIC LKH-123 .....	9611922934	9611922935
Service kit C/SIC LKH-124 .....	9611922679	9611922941
<b>Service kit for single shaft seal SIC/SIC</b>		
■ Service kit SIC/SIC LKH-112/ LKH-112P .....	9611922655	9611922656
Service kit SIC/SIC LKH-113/ LKH-113P .....	9611922661	9611922662
Service kit SIC/SIC LKH-114/ LKH-114P .....	9611922667	9611922668
Service kit SIC/SIC LKH-122 .....	9611922673	9611922674
Service kit SIC/SIC LKH-123 .....	9611922679	9611922680
Service kit SIC/SIC LKH-124 .....	9611922685	9611922686
<b>Service kit for flushed shaft seal C/SIC</b>		
○ Service kit C/SIC LKH-112/ LKH-112P .....	9611922099	9611922100
Service kit C/SIC LKH-113/ LKH-113P .....	9611922105	9611922106
Service kit C/SIC LKH-114/ LKH-114P .....	9611922111	9611922112
Service kit C/SIC LKH-122 .....	9611922412	9611922413
Service kit C/SIC LKH-123 .....	9611922937	9611922938
Service kit C/SIC LKH-124 .....	9611922943	9611922944

**Service kit for flushed shaft seal SIC/SIC**

♦	Service kit SIC/SIC LKH-112/ LKH-112P .....	9611922658	9611922659
	Service kit SIC/SIC LKH-113/ LKH-113P .....	9611922664	9611922665
	Service kit SIC/SIC LKH-114/ LKH-114P .....	9611922670	9611922671
	Service kit SIC/SIC LKH-122 .....	9611922676	9611922677
	Service kit SIC/SIC LKH-123 .....	9611922682	9611922683
	Service kit SIC/SIC LKH-124 .....	9611922688	9611922689

Parts marked with ◻♦◉■ are included in the service kits.

Recommended Spare Parts: Service kits. <sup>(900732/3)</sup>

Conversion single to flushed shaft seal : Please order Flushed service kit + pos. 24+25+26

---

**How to contact Alfa Laval**

Contact details for all countries are continually updated on our website.

Please visit [www.alfalaval.com](http://www.alfalaval.com) to access the information directly.

© Alfa Laval Corporate AB

This document and its contents is owned by Alfa Laval Corporate AB and protected by laws governing intellectual property and thereto related rights. It is the responsibility of the user of this document to comply with all applicable intellectual property laws. Without limiting any rights related to this document, no part of this document may be copied, reproduced or transmitted in any form or by any means (electronic, mechanical, photocopying, recording, or otherwise), or for any purpose, without the expressed permission of Alfa Laval Corporate AB. Alfa Laval Corporate AB will enforce its rights related to this document to the fullest extent of the law, including the seeking of criminal prosecution.