

Note that all unique customer requirements (i.e tolerance) need to be verified thru Alfa Laval.

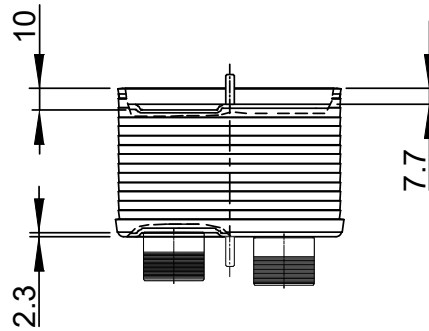
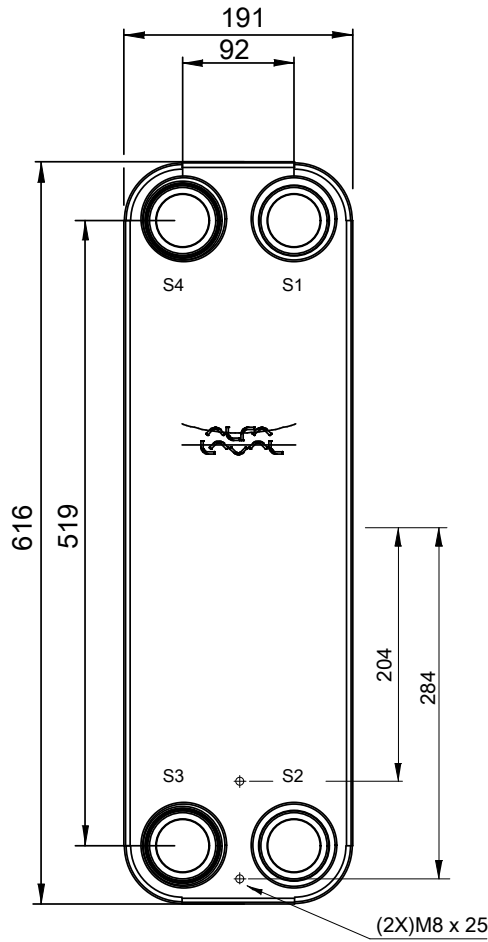
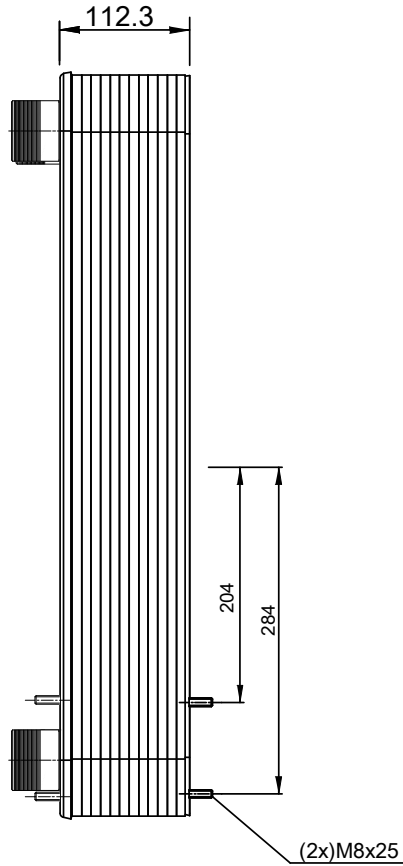
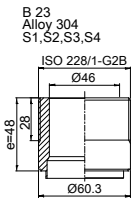

HEATING SURFACE  
 NETWEIGHT 19.9 kg  
 OPERATING WEIGHT kg  
 PLATE MATERIAL ALLOY 316  
 PLATE GROUPING 1\*18L/1\*19L

ALL DIMENSIONS IN MILLIMETERS

SIDE	MEDIA	INLET	TEMP.	OUTLET	TEMP.	FLOW RATE	PRESSURE DROP	LIQUID VOL.
1		S1		S2				3.99 dm <sup>3</sup>
2		S3		S4				3.78 dm <sup>3</sup>

PRESSURE VESSEL APPROVAL

PED



CB110-38L-F (3287119374)

[www.alfalaval.com](http://www.alfalaval.com)

CUSTOMER NAME / REF. NO.

TOTAL LENGTH 175.3 mm  
 TOTAL WIDTH 191.0 mm  
 TOTAL HEIGHT 616.0 mm

COMPANY / REF.



1/15/2024  
 REV 0