

Note that all unique customer requirements (i.e tolerance) need to be verified thru Alfa Laval.

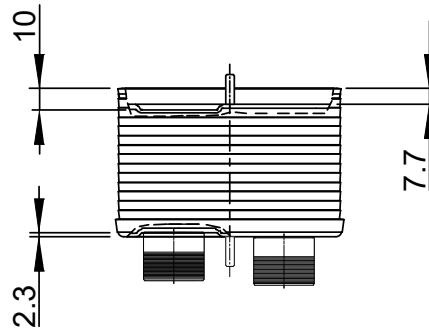

B 23
Alloy 316
S1,S2,S3,S4

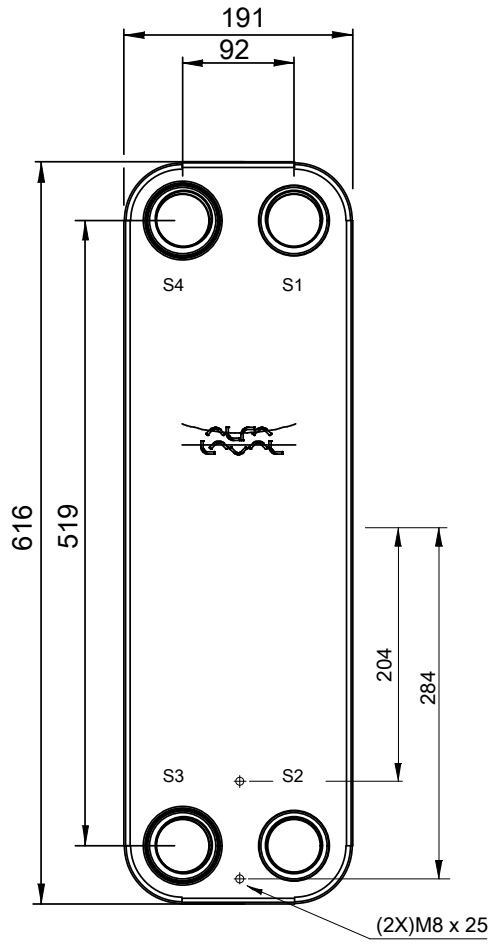
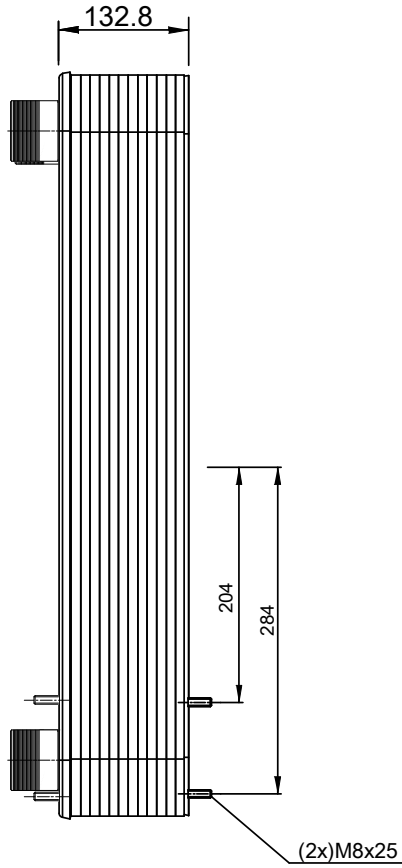
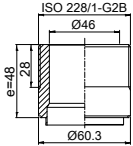

HEATING SURFACE
NETWEIGHT 22.7 kg
OPERATING WEIGHT kg
PLATE MATERIAL ALLOY 316
PLATE GROUPING 1*22H/1*23H

ALL DIMENSIONS IN MILLIMETERS

SIDE	MEDIA	INLET	TEMP.	OUTLET	TEMP.	FLOW RATE	PRESSURE DROP	LIQUID VOL.
1		S1		S2				4.83 dm ³
2		S3		S4				4.62 dm ³



PRESSURE VESSEL APPROVAL

PED

CB110-46H (3287101558)

www.alfalaval.com

CUSTOMER NAME / REF. NO.

COMPANY / REF.

TOTAL LENGTH 195.8 mm
TOTAL WIDTH 191.0 mm
TOTAL HEIGHT 616.0 mm



1/15/2024
REV 0