

ALS / ALB

Agitators

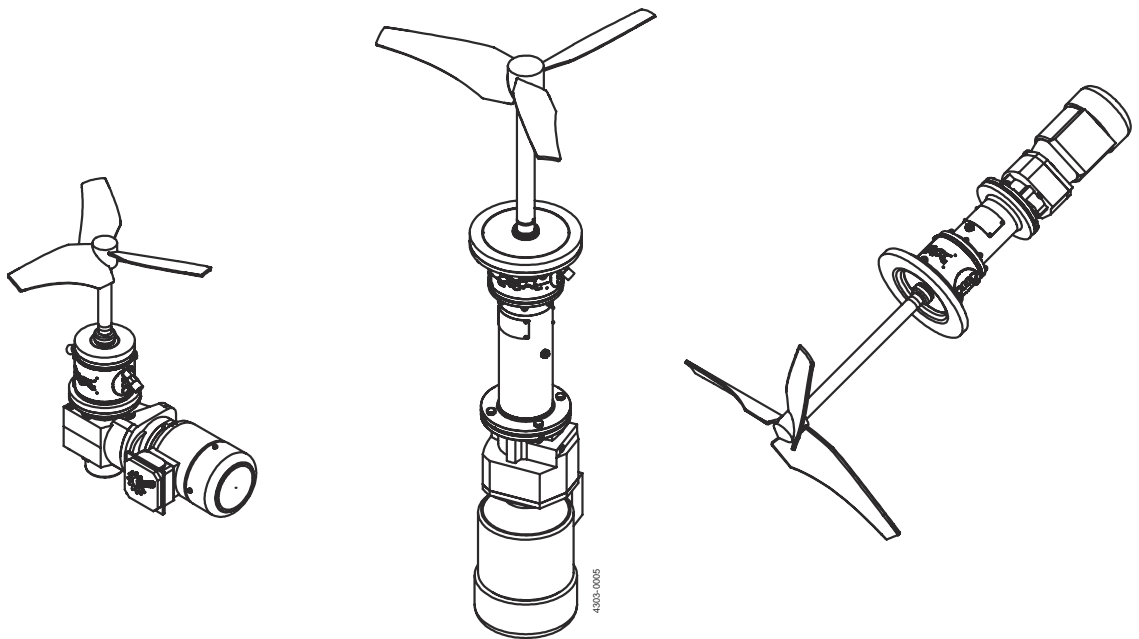

Lit. Code

200007949-1-EN-GB

Instruction manual

Published by
Alfa Laval Kolding A/S
Albuen 31
DK-6000 Kolding, Denmark
+45 79 32 22 00

The original instructions are in English

© Alfa Laval AB 2026-01

This document and its contents are subject to copyrights and other intellectual property rights owned by Alfa Laval AB (publ) or any of its affiliates (jointly "Alfa Laval"). No part of this document may be copied, re-produced or transmitted in any form or by any means, or for any purpose, without Alfa Laval's prior express written permission. Information and services provided in this document are made as a benefit and service to the user, and no representations or warranties are made about the accuracy or suitability of this information and these services for any purpose. All rights are reserved.

Contents

1	Declarations of Conformity	5
1.1	EU Declaration of Conformity.....	5
1.2	UK Declaration of Conformity.....	6
2	Safety	7
2.1	Safety signs.....	8
2.2	Safety precautions.....	9
2.3	Warning Signs in Text.....	12
2.4	Requirements of Personnel.....	13
2.5	Recycling Information.....	14
3	Introduction	15
3.1	Intended use.....	15
4	Installation	17
4.1	Unpacking/delivery.....	17
4.2	General installation.....	20
4.2.1	Welding flange.....	21
4.2.1.1	Guidelines for installing Flat Shaped Welding Flange (FSWF), ALS Agitator.....	22
4.2.1.2	Guidelines for installing Flat Shaped Welding Flange (FSWF), ALB Agitator.....	22
4.2.2	Welding procedure, flange (FSWF) without nose, ALS Agitator.....	23
4.2.3	Welding procedure, flange (FSWF) with nose, ALB Agitator.....	26
4.2.4	Mounting Agitator.....	28
4.2.5	Pre-use check.....	31
5	Operation	35
5.1	General operation.....	35
5.2	Operation/Control.....	35
5.3	Troubleshooting.....	37
5.4	Cleaning recommendations.....	39
5.5	Temperature limits.....	39
5.6	Pressure limits.....	40
6	Maintenance	41
6.1	General maintenance.....	41
6.1.1	Preventive maintenance.....	42
6.2	Replacement of drive unit with bearing frame.....	42
6.3	Replacement of drive unit (without bearing frame).....	44
6.4	Replacement of drive unit (Motor and shaft unit).....	45

6.5	Dismantling and mounting shaft (with bearing frame except BC160).....	46
6.6	Replacement of bearings, type B20, B25, B25/30, B35, B35/40, B45, B45/50, B55, B55/60.....	48
6.7	Replacement of bearings, type BC160DH.....	50
6.8	Replacement of bearing, type BC160D.....	51
6.9	Replacement of bearings type BC160.....	53
6.10	Replacement of shaft seal, type D.....	55
6.11	Replacement of shaft seal, type DC.....	58
6.12	Replacement of shaft seal, type S1.....	60
6.13	Replacement of shaft seal, type S2.....	62
6.14	Replacement of shaft seal, type S3.....	64
7	Technical Data.....	67
7.1	General technical data.....	67
7.2	Mounting angle for side mounted Agitator type ALS.....	67
7.3	Mounting angle for bottom mounted Agitator type ALB.....	68
7.4	Connecting flush – Seal type D.....	68
7.5	Connecting flush – Seal type DC.....	70
7.6	Tightening torques for bolt connections.....	71
7.7	Shaft alignment.....	72
7.8	Spider coupling.....	73
7.9	Storage.....	74
8	Parts Lists and Exploded Views.....	75
8.1	Agitator main components, drive end.....	75
8.2	Agitator main components, Wet end.....	77
8.3	Bearing frame, B20, B25, B25/30, B35, B35/40, B45, B45/50, B55, B55/60.....	79
8.4	Bearing frame BC160/35, BC160D/30, BC160DH/30.....	81
8.5	Shaft seal, type D.....	83
8.6	Shaft seal, type DC.....	84
8.7	Shaft seal, type S1.....	85
8.8	Shaft seal, type S2.....	86
8.9	Shaft seal, type S3.....	87
8.10	Tools.....	88
9	Appendix.....	89
9.1	Drive unit instructions.....	89

1 Declarations of Conformity

1.1 EU Declaration of Conformity

The designated company

Alfa Laval Kolding A/S, Albuen 31, DK-6000 Kolding, Denmark, +45 79 32 22 00

Company name, address and phone number

Hereby declare that

Designation	Serial no(s)
Agitator - EnSaFoil	AAC000000001-AAC999999999, 10.000-100.000, 100700000001-100799999999
ALX-ME-(GX)-BC160D(H)/30(L)F-SX-SH-PXXXXYYYY	ALX = ALB or ALS
ALX-ME-(GX)-BC160/35(L)F-SX-SH-PXXXXYYYY	GX = GC, GR or GP
ALX-ME-(GX)-BXX/XX(L)F-SX-SH-PXXXXYYYY	BXX/XX = B25/30, B35, B35/40, B45, B45/50, B55, B55/60
ALX-ME-(GX)-BC160D(H)/30(L)F-D(C)-SH-PXXXXYYYY	SX = S1, S2, S3
ALX-ME-(GX)-BC160/35(L)F-D(C)-SH-PXXXXYYYY	SH = S200-S2000
ALX-ME-(GX)-BXX/XX(L)F-D(C)-SH-PXXXXYYYY	PXXXX = E125, E150, E175, E200, E225, E250, E300, E350, E400, E450, E500, E550, E600, E650, E700, E750, E800, E900, E1000, E1100, E1300, E1500, E1700, E1900
ALX-ME-(GX)-ZZ(L)F-SX-SH-PXXXXYYYY	YYYY = D2P, D2LP, D3P, D3LP, D2G, D2LG, D3G, D3LG, U2P, U2LP, U3P, U3LP, U2G, U2LG, U3G, U3LG
ALX-ME-(GX)-ZZ(L)F-D(C)-SH-PXXXXYYYY	ZZ = 30, 35, 40, 45, 50, 55, 60, 65, 70, 75, 80, 90
Type	Type variation

is in conformity with the following directives with amendments:

- Machinery Directive 2006/42/EC
- RoHS Directive 2011/65/EU and amendments

The person authorised to compile the technical file is the signer of this document.

Vice President BU Hygienic Fluid Handling
Head of Product Management

Mikkel Nordkvist

Title

Name

Kolding, Denmark

1 January 2026



Place

Date (YYYY-MM-DD)

Signature

DoC Revison_ 02_012026



1.2 UK Declaration of Conformity

The designated company

Alfa Laval Kolding A/S, Albuen 31, DK-6000 Kolding, Denmark, +45 79 32 22 00

Company name, address and phone number

Hereby declare that

Agitator - EnSaFoil	AAC000000001-AAC999999999, 10.000-100.000, 100700000001-1007999999999
Designation	Serial no(s)
ALX-ME-(GX)-BC160D(H)/30(L)F-SX-SH-PXXXXYYYY	ALX = ALB or ALS
ALX-ME-(GX)-BC160/35(L)F-SX-SH-PXXXXYYYY	GX = GC, GR or GP
ALX-ME-(GX)-BXX/XX(L)F-SX-SH-PXXXXYYYY	BXX/XX = B25/30, B35, B35/40, B45, B45/50, B55, B55/60
ALX-ME-(GX)-BC160D(H)/30(L)F-D(C)-SH-PXXXXYYYY	SX = S1, S2, S3
ALX-ME-(GX)-BC160/35(L)F-D(C)-SH-PXXXXYYYY	SH = S200-S2000
ALX-ME-(GX)-BXX/XX(L)F-D(C)-SH-PXXXXYYYY	PXXXX = E125, E150, E175, E200, E225, E250, E300, E350, E400, E450, E500, E550, E600, E650, E700, E750, E800, E900, E1000, E1100, E1300, E1500, E1700, E1900
ALX-ME-(GX)-ZZ(L)F-SX-SH-PXXXXYYYY	YYYY = D2P, D2LP, D3P, D3LP, D2G, D2LG, D3G, D3LG, U2P, U2LP, U3P, U3LP, U2G, U2LG, U3G, U3LG
ALX-ME-(GX)-ZZ(L)F-D(C)-SH-PXXXXYYYY	ZZ = 30, 35, 40, 45, 50, 55, 60, 65, 70, 75, 80, 90
Type	Type variation

is in conformity with the following directives with amendments:

- The Supply of Machinery (Safety) Regulations 2008
- The Restriction of the Use of Certain Hazardous Substances in Electrical and Electronic Equipment Regulations 2012

Signed on behalf of: Alfa Laval Kolding A/S.

Vice President BU Hygienic Fluid Handling

Head of Product Management

Mikkel Nordkvist

Title

Name

Kolding, Denmark

1 January 2026



Place

Date (YYYY-MM-DD)

Signature

DoC Revison_ 03_012026



2 Safety

Read this first



This Instruction Manual is designed for operators and service engineers working with the supplied Alfa Laval product.

Operators must read and understand the **Safety, Installation and Operating** instructions of the supplied Alfa Laval product before carrying out any work or before you put the supplied Alfa Laval product into service!

Not following the instructions can result in serious accidents.

This documentation describes the authorized way to use the supplied Alfa Laval product. Alfa Laval will take no responsibility for injury or damage if the equipment is used in any other way.

This Instruction Manual is designed to provide the user with the information to perform tasks safely for all phases in the lifetime of the supplied Alfa Laval product.

The operator shall always read the chapter **Safety** first. Hereafter the operator can skip to the relevant section for the task to be carried out or for the information needed.

Always read the chapter **Technical Data** thoroughly.

This is the complete Instruction Manual for the supplied Alfa Laval product.



NOTE

The illustrations and specifications in this Instruction Manual were effective at the date of printing. However, as continuous improvements are our policy, we reserve the right to alter or modify the Instruction Manual without prior notice or any obligation.



The English version of the Instruction Manual is the original manual. Alfa Laval cannot be held responsible for incorrect translations. In case of doubt, the English version applies.

2.1 Safety signs

Mandatory action signs

	General mandatory action sign.
	Refer to instruction manual.
	Use ear protection in noisy environments - noise protector.

Warning signs

	General warning.
	Electricity.
	Corrosive substance.

2.2 Safety precautions

NOTE

Unsafe practices and other important information are emphasised in this Instruction manual.

Warnings are emphasised by means of special signs.

All warnings in the Instruction manual are summarised on these pages.







Always read the Instruction manual before using the Agitator.

Illustrations are only to illustrate the problem and is NOT a drawing of the current Agitator.







WARNING

Pay special attention to the instructions below so that severe personal injury and/or damage to the Agitator are avoided.





Installation

 	<p>Always read <i>Technical Data</i> on page 67 thoroughly.</p> <p>Always follow installation instructions thoroughly (see <i>Installation</i> on page 17).</p>
	<p>Never expose the Agitator to undue vibrations or shocks.</p>
	<p>Never start the Agitator in the wrong rotation direction.</p>
	<p>Ensure that the tank media is not corrosive to the Agitator.</p>
	<p>Only install the Agitator in environments within temperature limit: -20°C and +40°C.</p> <p>Only install the Agitator in altitudes less than 1000 m above sea level.</p>
	<p>Never touch the moving parts while the Agitator is connected to the power supply.</p>

Operation

 	<p>Always read <i>Technical Data</i> on page 67 thoroughly.</p> <p>Always read supplier instructions thoroughly (see <i>Appendix</i> on page 89).</p>
	<p>Never start the Agitator in the wrong rotation direction.</p>
	<p>Always rinse well with clean water after cleaning.</p>
	<p>Beware of temperature limitations.</p>
	<p>Never operate continuously within 20% of critical oscillation speed (see <i>Technical Data</i> on page 67).</p>
	<p>Never touch the moving parts while the Agitator is connected to the power supply.</p>



Maintenance

 	<p>Always read <i>Technical Data</i> on page 67 thoroughly.</p> <p>Always follow the maintenance instruction thoroughly (see <i>Maintenance</i> on page 41).</p> <p>Always follow the maintenance instruction from drive unit supplier (see <i>Appendix</i> on page 89).</p> <p>Always study the parts list and assembly drawing carefully (see <i>Parts Lists and Exploded Views</i> on page 75).</p>
	<p>Never touch the moving parts while the Agitator is connected to the power supply.</p> <p>Always disconnect the power supply while servicing the Agitator.</p>
	<p>Ensure correct rotation direction of impeller before startup and after any maintenance which might have impact on the direction.</p>

Transportation

	<p>Always transport the Agitator in original packaging.</p> <p>Always support the shaft adequately, to protect shaft and bearings.</p> <p>Never expose the Agitator to undue vibrations or shocks.</p> <p>Control for oil leakage on gears with vent screw.</p>
---	--

Storage

	<p>Store the Agitator in dry and clean environments. Rotate shaft every second week to ensure seal faces do not stick together.</p>
 	<p>Alfa Laval recommends:</p> <ul style="list-style-type: none"> • Store the supplied Alfa Laval product as supplied in original packaging • Port opening(s) should be protected against ingress • Bare steel (not stainless) should be lightly oiled/greased • Store in a clean, dry place without direct sunlight or UV light • Temperature range -5° C to +40° C (23° F - 104° F) • Relative humidity less than 60% • No exposure to corrosive substances (including contained air) • Rinse supplied Alfa Laval product with clean water before storage

Noise

	<p>Beware of Agitator in operation can produce sound levels in excess of 85dB(A).</p>
--	---

2.3 Warning Signs in Text

Pay attention to the safety instructions in this Instruction Manual.

Below are definitions of the four grades of warning signs used in the text where there is a risk for injury to personnel or damage to the supplied Alfa Laval product.

 **DANGER**

Indicates an imminently hazardous situation which, if not avoided, will result in death or serious injury.

 **WARNING**

Indicates a potentially hazardous situation which, if not avoided, could result in death or serious injury.

 **CAUTION**

Indicates a potentially hazardous situation which, if not avoided, may result in minor or moderate damage to the supplied Alfa Laval product.

 **NOTE**

Indicates important information to simplify or clarify procedures.

2.4 Requirements of Personnel

Operators

The operators shall read and understand this Instruction Manual.

Maintenance personnel

The maintenance personnel shall read and understand this Instruction Manual. The maintenance personnel or technicians shall be skilled within the field required to carry out the maintenance work safely.

Trainees

Trainees can perform tasks under the supervision of an experienced employee.

People in general

The public shall not have access to the supplied Alfa Laval product.

In some cases, specially skilled personnel may need to be hired (i.e. electricians, welders). In some cases the personnel has to be certified according to local regulations with experience of similar types of work.

2.5 Recycling Information

Unpacking

Packing material may consist of wood, plastics, cardboard boxes and in some cases metal straps.



- Wood and cardboard boxes can be reused, recycled or used for energy recovery
- Plastics should be recycled or burnt at a licensed waste incineration plant
- Metal straps should be sent for material recycling

Maintenance

During maintenance, oil (if used) and wear parts in the supplied Alfa Laval product should be replaced.

- Oil and all non-metal wear parts must be disposed of in accordance with local regulations
- Rubber and plastics should be burnt at a licensed waste incineration plant. If not available they should be disposed of in accordance with local regulations
- Bearings and other metal parts should be sent to a licensed handler for material recycling
- Seal rings and friction linings should be disposed of to a licensed land fill site. Check your local regulations
- All metal parts should be sent for material recycling
- Worn out or defected electronic parts should be sent to a licensed handler for material recycling

Scrapping

At end of use, the equipment must be recycled in accordance with the relevant local regulations. Besides the equipment itself, any hazardous residues from the process liquid must be considered and dealt with in a proper manner. When in doubt, or in the absence of local regulations, please contact your local Alfa Laval sales company.

3 Introduction

The Alfa Laval ALS is a side-mounted agitator for hygienic mixing and blending in atmospheric and pressurized tanks. Its versatile, modular and hygienic design enables customization to meet the requirements of virtually any duty and ensures cost-effective, energy-efficient operation. Exceptional cleanability through Cleaning-in-Place makes the ALS agitator ideal for use in sterile and aseptic applications. An ATEX-certified version is available for use in potentially explosive environments.

The Alfa Laval ALB is a bottom-mounted agitator for hygienic mixing and blending in atmospheric and pressurized tanks. Its versatile, modular and hygienic design enables customization to meet the requirements of virtually any duty and ensures cost-effective, energy-efficient operation. Exceptional cleanability through Cleaning-in-Place makes the ALB agitator ideal for use in sterile and aseptic applications.

3.1 Intended use

- The Alfa Laval Agitator is only for mixing/stirring of liquids in a tank
- The Agitator is only for mounting positions as specified on the nameplate by the first group of letters of the type designation

ALT(B)- is for top mounting, ALS- is for side mounting and ALB- is for bottom mounting. The exact mounting angle is specified on the nameplate and must be followed. Definitions on mounting angles can be seen in section [Mounting angle for side mounted Agitator type ALS](#) on page 67 and section [Mounting angle for bottom mounted Agitator type ALB](#) on page 68.

- The different duties and operation data like pressure, speed and media temperature, which the Agitator is designed for, can be found in the Alfa Laval quotation agreement¹ and may not be exceeded by all means
- If the Agitator is installed in pressurized tanks local regulations and legislations must be met

¹ The Alfa Laval quotation agreement has been exchanged during the quote process between a technical purchaser and Alfa Laval. If you are not in hold of the Alfa Laval quotation agreement, please get through to your local Alfa Laval contact, inform the Agitator serial number and article number which is stated on the Name Plate and you will obtain the Alfa Laval quotation agreement.

This page is intentionally left blank.

4 Installation

4.1 Unpacking/delivery

NOTE

The instruction manual is part of the delivery.

Study the instructions carefully and pay special attention to the warnings!

Alfa Laval cannot be held responsible for incorrect unpacking.

WARNING

Always use lifting equipment when handling the Agitator, see lifting instructions below.

Inspect the delivery for visible transportation damages - all issues to be reported to carrier.

Check the delivery for:

1. Complete Agitator
2. Nameplate designations
3. Delivery note
4. Separate instruction manuals from suppliers (see [Appendix](#) on page 89).

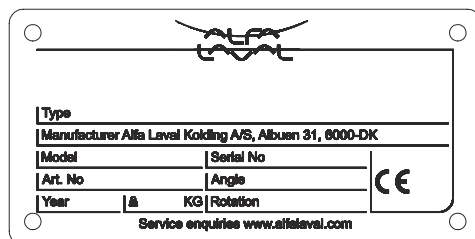

Lifting instructions

WARNING

Always use the correct lifting equipment (see Agitator weight on name plate).

Locate centre of gravity before moving the Agitator.

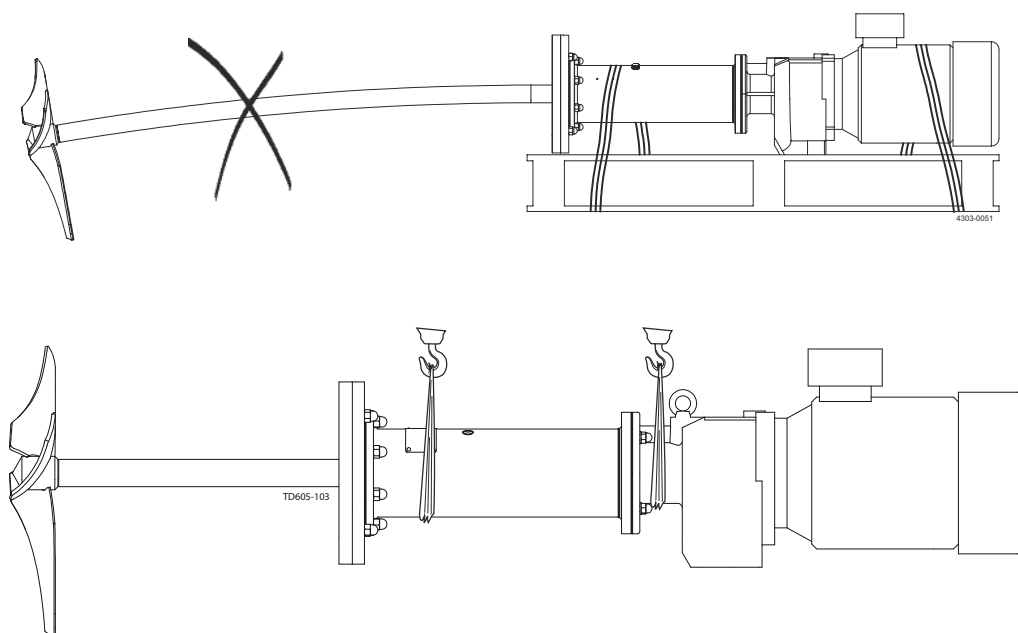

! WARNING

Do **NOT** use eye bolts on gear motor to lift the Agitator. They are only for gear motor removal.

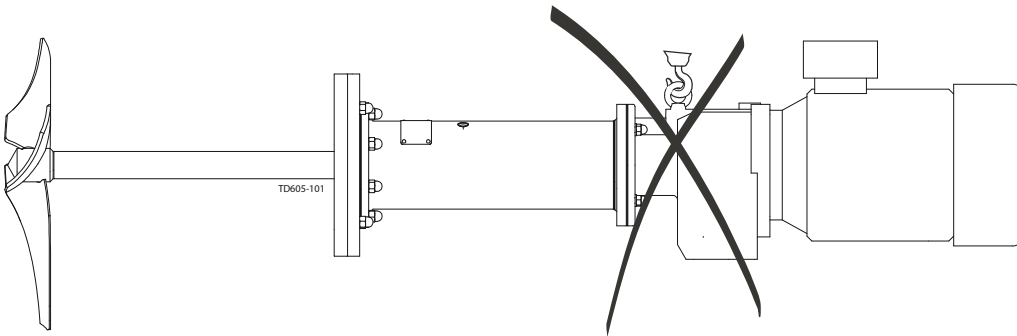
**! WARNING**

Do **NOT** use eye bolts on shroud (if any) to lift the Agitator. They are only for shroud removal.

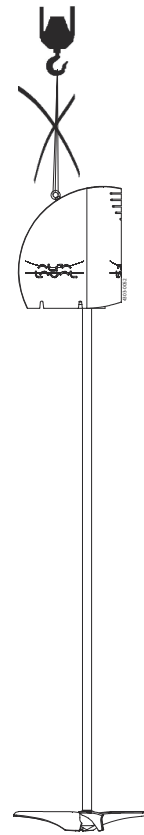
**! CAUTION**

Alfa Laval recommends **NOT** to use shaft as lifting point but long shafts must be supported adequately during lifting to protect shaft, bearings and seals arrangements.

Gear motor/motor may be used for lifting the assembled Agitator.

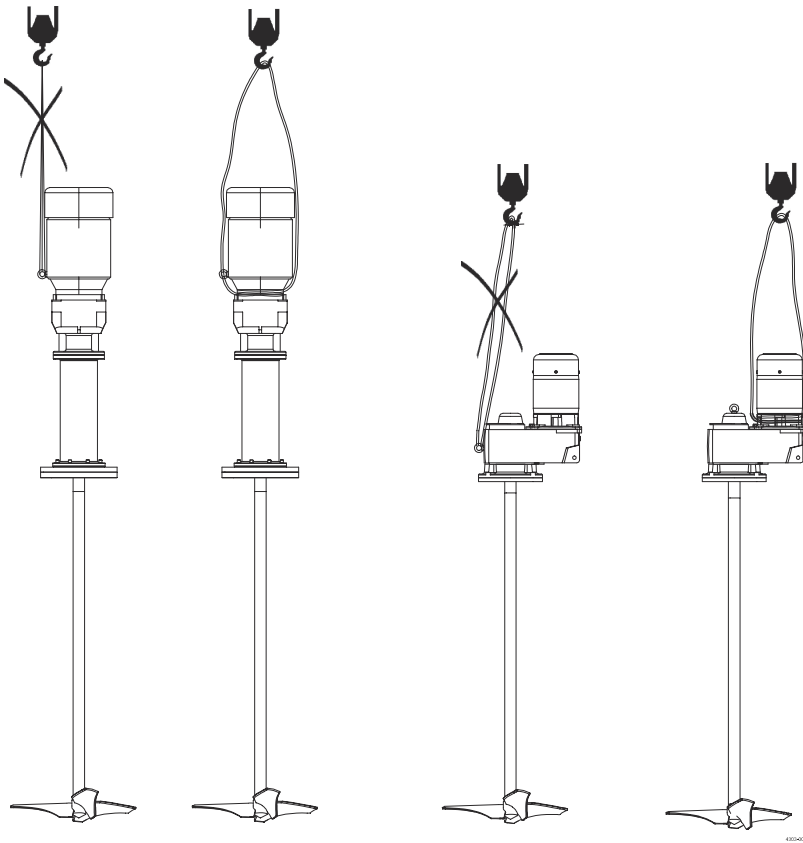
**NOTE**

If possible, lift the Agitator in horizontal position, and in two points.

During transportation**WARNING**

Always support the shaft adequately to protect shaft and bearings.

Never expose the Agitator to undue vibrations or shocks.

Control for oil leakage on gears with vent screw.

4.2 General installation

NOTE

Study the instructions carefully and pay special attention to the warnings!

Always check the Agitator before operation - see [Pre-use check](#) on page 31.

The Agitator is for permanent fastening.

Make sure that the motor correspond to the environment.

WARNING

Always read the [Technical Data](#) on page 67 thoroughly.

Only install this Agitator in mounting angle according to the name plate (see [Technical Data](#) on page 67).

Always use lifting equipment when handling the Agitator (see [Unpacking/delivery](#) on page 17).

Always have safety elements removed by authorized personnel.

Never cover or remove the nameplate.

WARNING

Never connect to power supply during installation or service.

Always have the Agitator connected to power supply by authorized personnel.



NOTE

Alfa Laval highly recommends to install motor protection guard to protect the motor from overloading.

Never install a none Alfa Laval shroud on the Agitator as it can lead to overheat and a breakdown of the motor.

4.2.1 Welding flange



Only authorized personnel to weld in flanges.
Alfa Laval cannot be held responsible for incorrect installation.

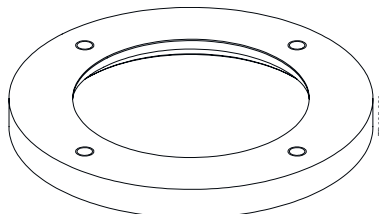

- 1 Dismantle the welding flange if fitted onto the Agitator.

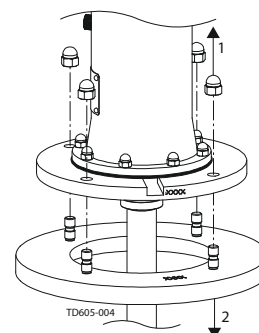

- 2 Ensure that the tank, where the welding flange is to be welded in, can handle the forces applied by the agitator: Torque M_v , Bending torque M_b and Side thrust F_s .

The values are depending on the Agitator configuration. The following information is required to calculate the forces:

- P: Power of the motor in [kW]
- n: Speed of Agitator shaft [RPM]
- S: Shaft length according to Agitator type designation -Sxxxx- in [mm]
- D: Largest impeller diameter according to Agitator designation -Pxxx- in [mm]

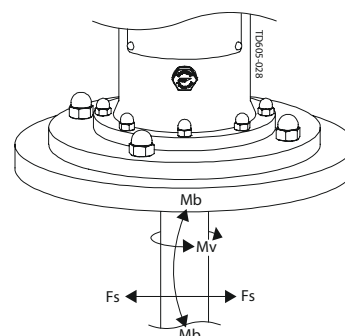

The values can be calculated as follows:

Type ALS / ALB:
$M_v \text{ [Nm]} = 23873 \times P / n$
$F_s \text{ [N]} = 1.8 \times M_v \times 1000 / D$
$M_b \text{ [Nm]} = F_s \times S / 1000$

- 3 During the design phase of the tank, ensure sufficiently rigidity of the tank.

Ensure that the max. bending angle (A), at loads from Step 2 does not exceed according to below scheme.

RPM:	<100	>100
A° (max bending angle at applied loads):	0.1	0.05

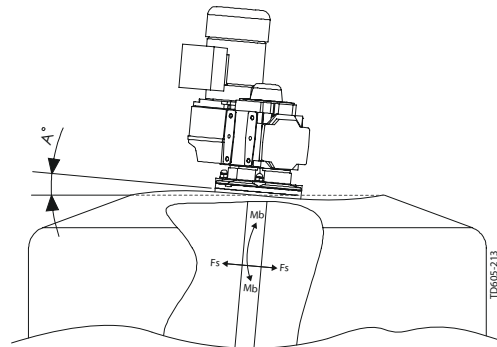

4.2.1.1 Guidelines for installing Flat Shaped Welding Flange (FSWF), ALS Agitator

For mounting flange without nose



Alfa Laval recommend that all other welding tasks on the tank are finished before cutting the hole for the flange.

ALS Agitator must be installed in the tank as shown in section [Mounting angle for side mounted Agitator type ALS](#) on page 67 which can be achieved as shown on the illustration below.

1. Tank wall
2. Cone for welding flange
3. Welding flange

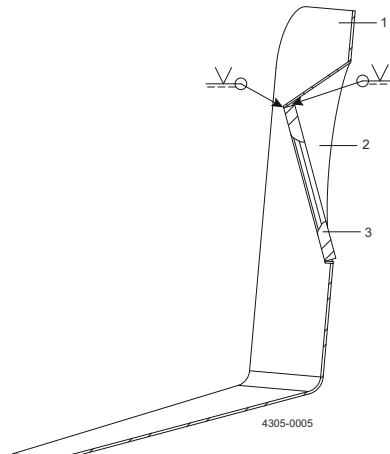
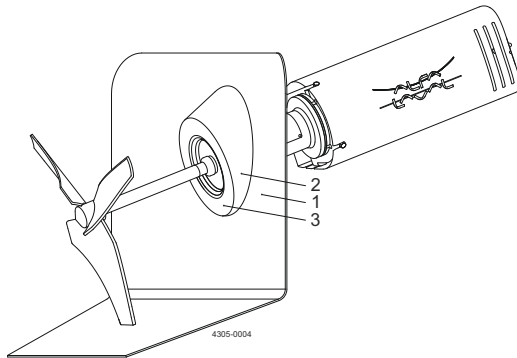

4.2.1.2 Guidelines for installing Flat Shaped Welding Flange (FSWF), ALB Agitator

For mounting flange with nose



Alfa Laval recommend that all other welding tasks on the tank are finished before installing welding flange in the tank.

ALB Agitator must be installed in the tank as shown in section [Mounting angle for bottom mounted Agitator type ALB](#) on page 68 which can be achieved as shown on the illustration below.

In case of installation of Welding Flange parallel to tank bottom surface (shaft perpendicular to tank bottom surface) it is always recommended to use a bead/cone. This is to ensure that tank bottom stresses / forces are not transmitted directly to the Welding Flange increasing the risk of leakages.

1. Tank bottom
2. Cone for welding flange
3. Welding flange

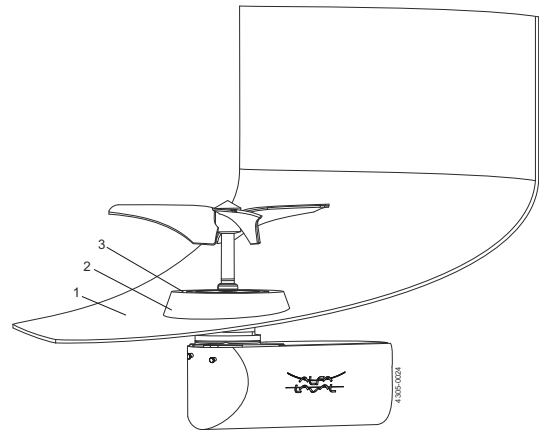

1. Tank bottom
2. Cone for welding flange
3. Welding flange
4. Weldings

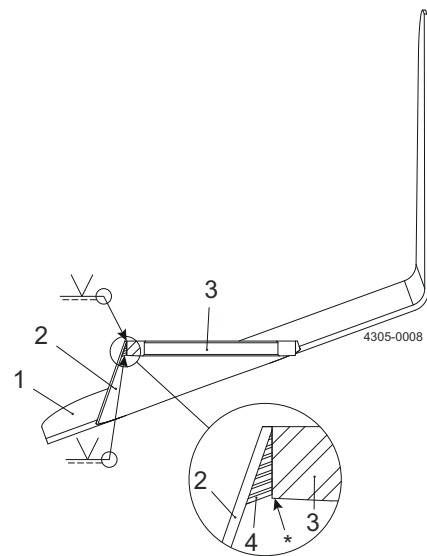

CAUTION

Ensure that no weldings are applied to the outside surface of the welding flange* as the Agitators mounting flange has the same size as the welding flange. If weldings by mistake are applied to the surface of the welding flange it must be removed by grinding, or the like, to ensure a correct fit and installation of the mounting flange.

4.2.2 Welding procedure, flange (FSWF) without nose, ALS Agitator

For mounting flange without nose

- 1 **Always** allow flange to cool to ambient temperature after each section has been welded.

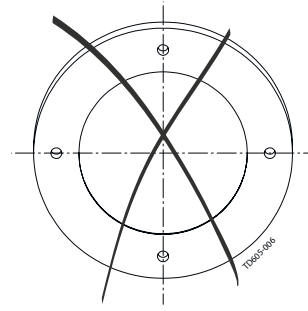

a) Position the flange correctly.

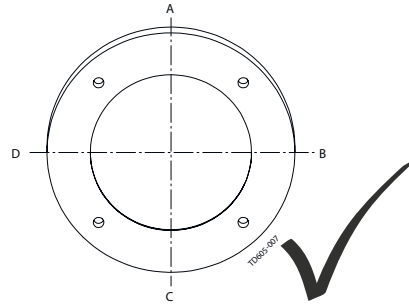

- 2 Spot weld from outside.

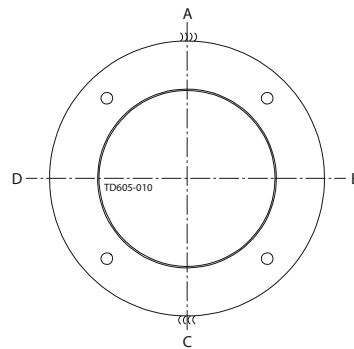

a) Adjust alignment!

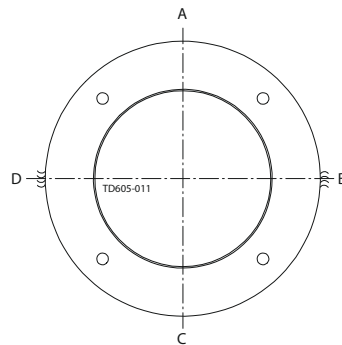

- 3 Weld the following sections first from outside then from inside, and cool with air between each section.

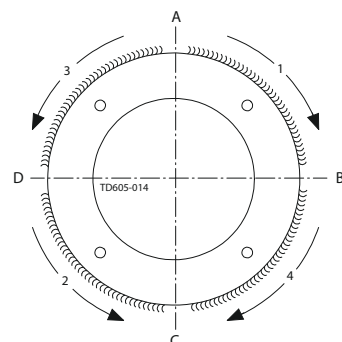

- 4 Ensure that the surface flatness tolerance equals 0.25 after welding. Grind and polish the welding flange. Use a solid straight ruler and a feeler gauge to determine the flatness.

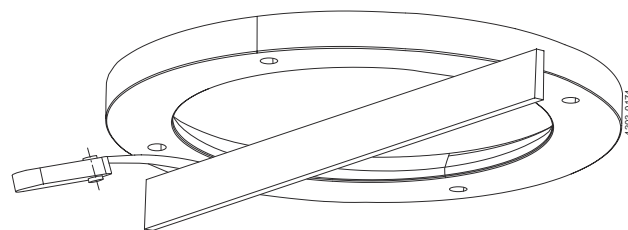

4.2.3 Welding procedure, flange (FSWF) with nose, ALB Agitator

NOTE

Alfa Laval recommend a welding tool with, if possible, build in cooling by flowing water, to be made and fixed to the FSWF to ensure shape and form of the FSWF during welding and installation.

In general Alfa Laval recommend to weld the welding flange onto a bended rim of the tank bottom plate – this is to secure adequate flexibility at high loads, e.g. when the tank is filled. If a bended rim is impossible to obtain due to a high plate thickness, Alfa Laval recommend to weld the welding flange onto a cone shaped plate section.

If not following the above recommendations there will be a risk that the flange can deform, especially at high tank fillings, which can cause a leakage between the welding flange and the agitator mounting flange.

- 1 Position the flange correctly.

Always allow flange to cool to ambient temperature after each section has been welded.

- 2 Spot weld from outside.

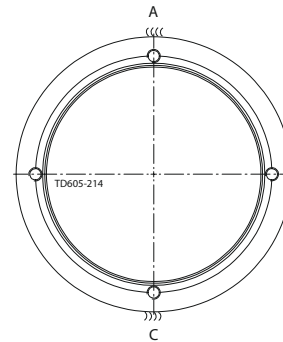

a) Adjust alignment!

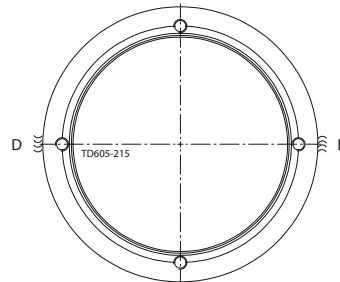

- 3 Spot weld from inside.

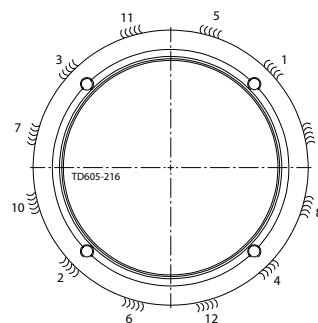

- 4 Weld the following sections first from inside then from outside and cool to ambient temperature after each section has been welded.

a) Cool with air!

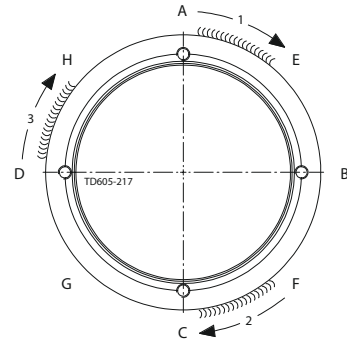

b) Cool with air!

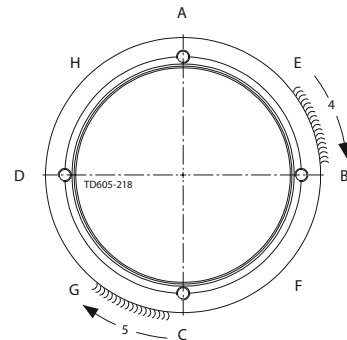

c) Cool with air!

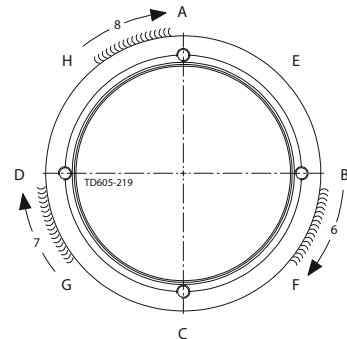

- 5 Remove the welding tool.

Ensure that the surface flatness tolerance equals ± 0.1 mm.

Grind and polish the welding flange.

4.2.4 Mounting Agitator

CAUTION

Always ensure that mounting is carried out according to description shown in section [Mounting angle for side mounted Agitator type ALS](#) on page 67 and [Mounting angle for bottom mounted Agitator type ALB](#) on page 68.

Always refer to tightening torques in section [Tightening torques for bolt connections](#) on page 71 when tightening bolts.

1 Place impeller device(s) in the tank.

Ensure that tank and Agitator surfaces are clean.

Ensure that drain (I) is pointing downwards.

For gears with vent screw, ensure the vent is pointing upwards and the rubber plug (III) is removed (see [Drive unit instructions](#) on page 89).

1) Standard vent plug

2) Transport securing device

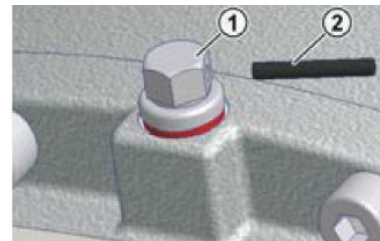
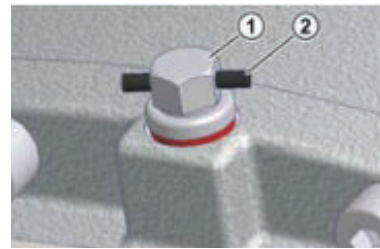
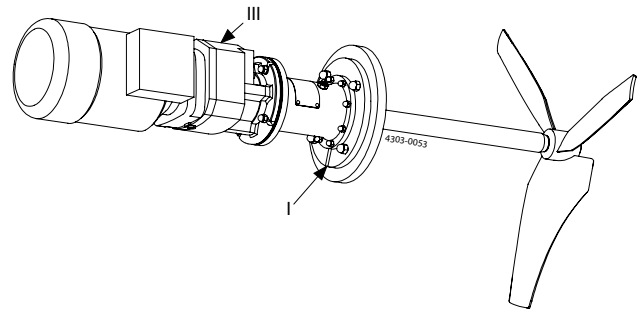

2 Mount the Agitator onto the tank.

3 Mount impeller device(s) onto shaft.

All-weld propeller to shaft with one welding seam at a time, cool with air and continue with one welding until welding is according to illustration. Use welding procedures which introduce as less heat, tension and bending to the shaft as possible.

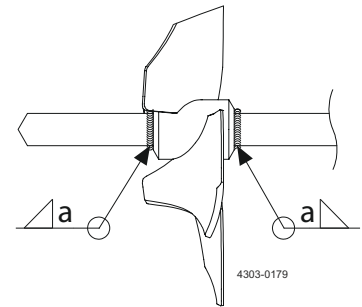
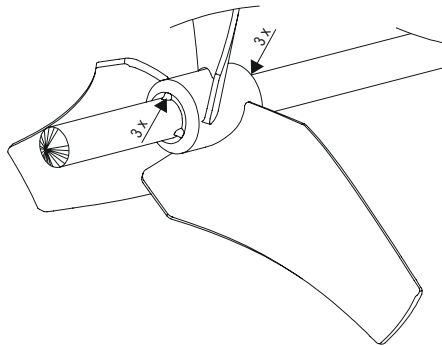

Hub diameter (mm)	a - dimension (mm)
Ø30	1.1
Ø40	1.8
Ø55, Ø80, Ø120	2.8

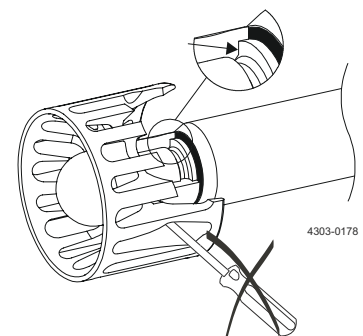
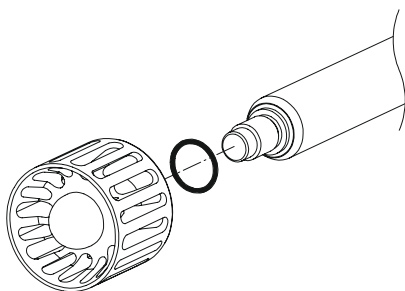
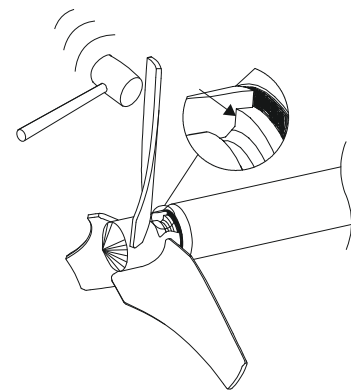
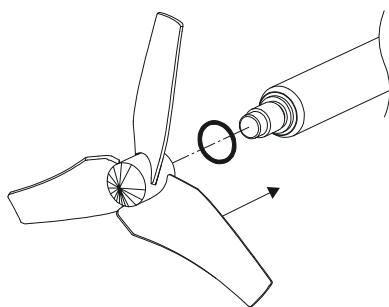
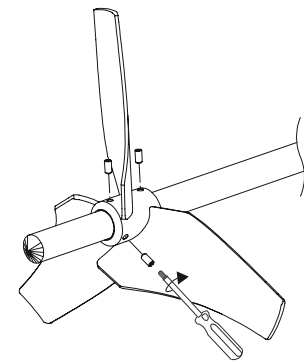
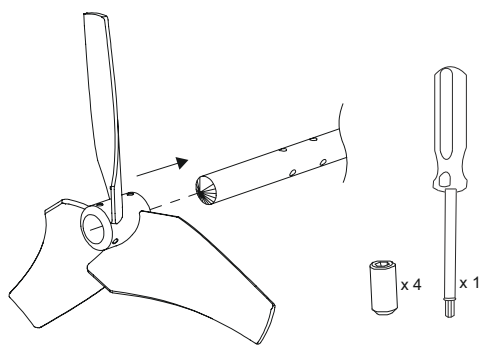

- 4 Ensure the impeller device orientation is correct according to the direction of the desired flow. The direction is determined by the letter "D" or "U" in the last part of the agitator type description. E.g. -P400D3P has the letter "D" which means the flow direction is away from the drive unit. -P400U3P has the letter "U" which means the flow direction is towards the drive unit.

- 5 Ensure the impeller is positioned, keeping minimum radial distance to the tank.

Clearance $> S/15$ and clearance > 100 mm

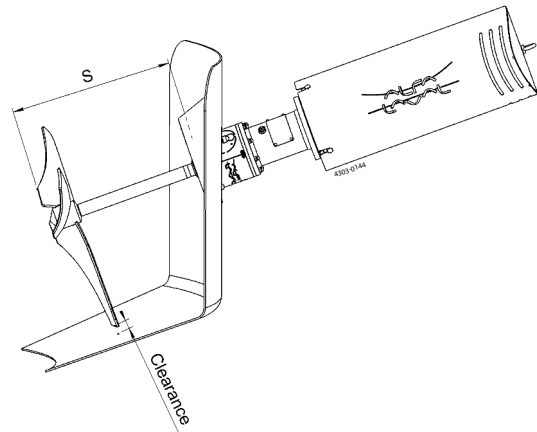

- 6 If propellers has been all-welded to the shaft (not if it has been all-welded to the shaft-end) it can be necessary to align the shaft, using heat and or bending forces according to specifications and instructions in chapter [Shaft alignment](#) on page 72.

WARNING

Do **NOT** connect the power supply until installation is completed.

CAUTION

Follow instructions in section [Drive unit instructions](#) on page 89.

Ensure that the rotation direction is according to nameplate.

Always perform pre-use check before operation (see section [Pre-use check](#) on page 31).

NOTE

On closed tanks, Alfa Laval recommends installing a manhole circuit breaker, cutting power supply if hatch is open.

4.2.5 Pre-use check

NOTE

Study the instructions carefully and pay special attention to the warnings!

Always check the Agitator before operation - see section [Pre-use check](#) on page 31.

The Agitator is only designed to operate according to data given in section [Intended use](#) on page 15, [Mounting angle for side mounted Agitator type ALS](#) on page 67 and [Mounting angle for bottom mounted Agitator type ALB](#) on page 68.

Check the rotation direction before operation.

Always make sure that the motor corresponds to the environment.

WARNING

Never install the Agitator in environments which deviate from those given in section [Intended use](#) on page 15 and [Technical Data](#) on page 67.

Always ensure that all alignment specifications given in section [Shaft alignment](#) on page 72 are followed.

- 1 Go through section [Safety precautions](#) on page 9.
- 2 Check the fastenings.
- 3 Check O-ring and impeller are correctly fitted.
- 4 Check impellers **CANNOT** collide with tank vessel at any point during a full rotation.
Clearance > $S/15$ and clearance > 100 mm

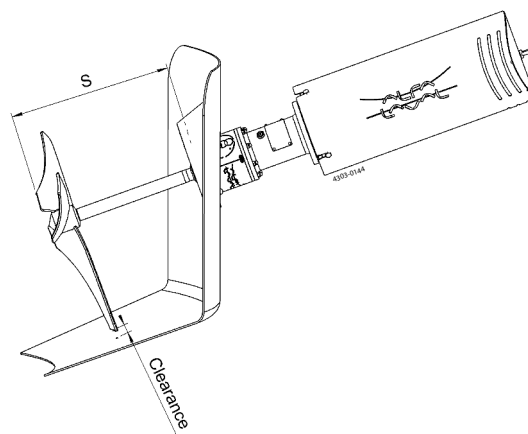

5 Seal type S1, S2, S3

- Ensure the sealing surfaces are not stuck together, by slowly turning shaft by hand
- Ensure that the seal is always submerged during operation

NOTE

Dry running will damage the seal faces.

6 Seal Type D

Ensure the sealing surfaces are not stuck together, by slowly turning shaft by hand.

Ensure that the seal never runs dry.

Ensure flush connections are installed in such way that air pockets are avoided.

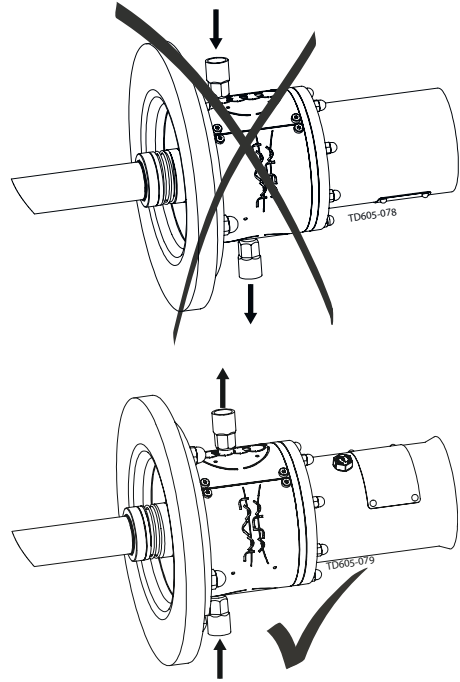

7 Seal Type DC

Ensure the sealing surfaces are not stuck together, by slowly turning shaft by hand.

Ensure that the seal never runs dry.

Ensure flush connections are installed in such way that air pockets are avoided.

Ensure that the distance pieces (1) on the seal are mounted as shown on illustration.

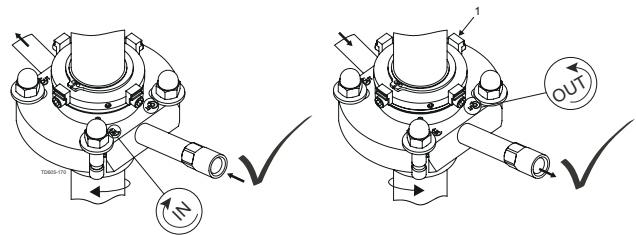

8 Ensure that drain (I) is pointing downwards.

For gears with vent screw, ensure the vent is pointing upwards and the rubber plug (III) is removed (see [Drive unit instructions](#) on page 89 and mounting instructions in section [Mounting Agitator](#) on page 28).

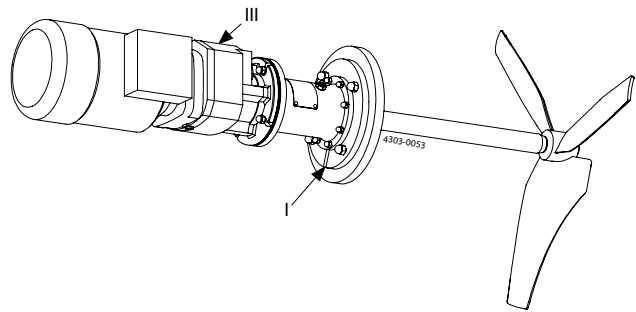

9 (Only for agitators with bearing frame)

Ensure that the PreVent valve is refitted in the bearing frame.

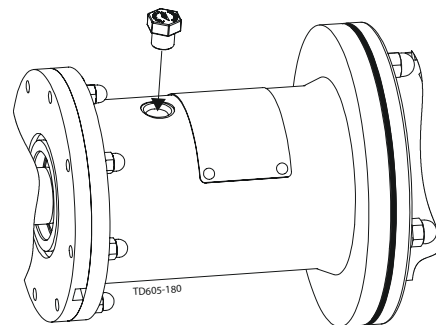

- 10 Ensure that the rotation direction is according to nameplate before starting the Agitator.

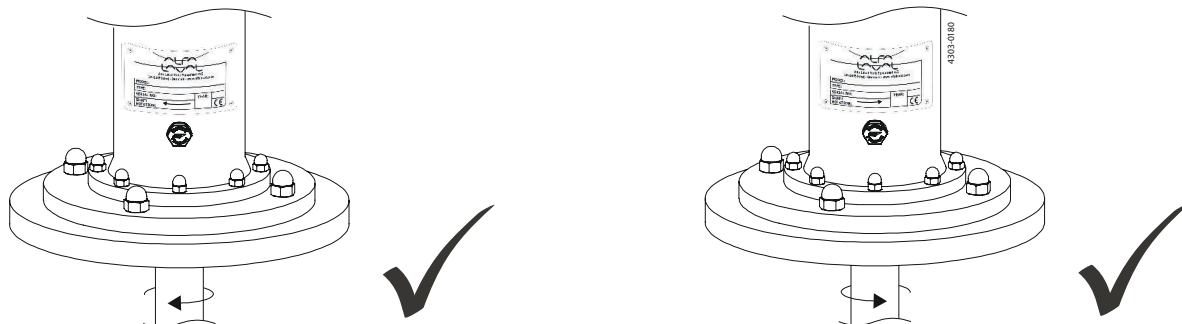

- 11 If frequency converter drive is used, it must be ensured NOT to operate continuously within +/-20% of critical oscillation speed (see section *Intended use* on page 15 and *Technical Data* on page 67).

- 12 Alfa Laval recommend a soft starter or a frequency converter for the Agitator to reduce the load on tank and Agitator. For operation instructions from suppliers see *Appendix* on page 89.

The ramp up and ramp down time should be about 2-5 seconds.

This page is intentionally left blank.

5 Operation

5.1 General operation

NOTE

Study the instructions carefully and pay special attention to the warnings!

Always check the Agitator before operation - see [Pre-use check](#) on page 31.

Alfa Laval recommends a soft starter or a frequency converter for the Agitator to reduce the load on tank and Agitator. For operation instructions from suppliers (see chapter [Appendix](#) on page 89).

5.2 Operation/Control

WARNING

If deviation from normal operation and intended use shown in section [Intended use](#) on page 15, immediately switch off the Agitator and find the cause of failure (see section [Troubleshooting](#) on page 37).

The Agitator is designed to max 5 starts per hour.

NOTE

Inspect the Agitator regularly

Drive unit

	Inspect / Clean / Lubricate			
	Supplier instruction	Weekly	Monthly	Half-yearly
Motor	x			
• Clean surfaces - to avoid overheating		x		
Gear	x			
• Clean vent screw (if any)		x		
• Check for oil leakage		x		

Flange

	Inspect / Clean / Lubricate			
	Supplier instruction	Weekly	Monthly	Half-yearly
Clean drain			x	

Sealing

	Inspect / Clean / Lubricate				
	Supplier instruction	Weekly	Monthly	Half-yearly	Yearly
Mechanical seal					
• NOT flushed: S1, S2, S3			x		
• Flushed: D, DC			x		

Bearing frame

	Inspect / Clean / Lubricate			
	Supplier instruction	Weekly	Monthly	Half-yearly
Clean PreVent screw		x		
Check spider clearance				x
Check gaskets				x
Lubricate radial seals				x

Impeller device

	Inspect / Clean / Lubricate			
	Supplier instruction	Weekly	Monthly	Half-yearly
Sticky media				
• Clean impeller device			x	
Abrasive media				
• Check blade thickness ¹			x	
• Check fastening of pointed set screws			x	

¹ If any suspicion of reduction in blade thickness, contact Alfa Laval and inform serial no stated on the name plate.

5.3 Troubleshooting

Problem: Not starting

Part	Cause/result	Remedy
Drive unit	<ul style="list-style-type: none"> Defect Fault at power supply 	Dismantle drive unit, check for correct rotation. Replace drive unit. Check power supply connection. Check voltage and frequency correspond with name plate. Check frequency converter adjustment correspond to name plate.
Agitator	<ul style="list-style-type: none"> Obstructed 	Check Agitator can rotate freely without striking anything.
Bearing frame		Ensure that retainer bolt has been removed.

Problem: Vibrations

Part	Cause/result	Remedy
Impeller device	<ul style="list-style-type: none"> Damaged Unbalanced impeller Damage to shaft seal 	Contact Alfa Laval. Clean impeller device. Replace sealing.
Shaft	<ul style="list-style-type: none"> Damaged 	Contact Alfa Laval.
Other	<ul style="list-style-type: none"> Deviation from normal operation Increased / decreased temperature 	Operation circumstances must equal to those it was designed for ¹ .

¹ See section *Intended use* on page 15

Problem: Unusual noise

Part	Cause/result	Remedy
Bearing frame	<ul style="list-style-type: none"> Bearing gap Wear or damaged bearings 	Replace bearings and all gaskets in bearing frame immediately. Replace bearings and all gaskets in bearing frame.
Drive unit	<ul style="list-style-type: none"> Defect Bearing gap Increased / decreased power No grease 	Replace drive unit. Renovate or change the drive unit immediately. Switch of power supply. Replace drive unit.
Sealing	<ul style="list-style-type: none"> Wear sealing Seal is not flushed ² Seal surfaces stick together 	Replace sealing. Replace sealing and ensure that the seal never run dry ² . Separate surfaces carefully and clean them - ensure that seals are sufficient cleaned before still stand.
Other	<ul style="list-style-type: none"> Deviation from normal operation Circuit overload 	Operation circumstances must equal to those it was designed for ¹ .

¹ See section *Intended use* on page 15

² Type S and S3 are designed for dry running

Problem: Leakage

Part	Cause/result	Remedy
Gear	<ul style="list-style-type: none"> Oil leakage 	Renovate or change the gear immediately.
Sealing	<ul style="list-style-type: none"> CIP fluid or other 	Replace sealing.

Problem: Continuously breakdown

Part	Cause/result	Remedy
Drive unit	<ul style="list-style-type: none"> Defect Too high frequency 	Replace motor. Regulate frequency down.
Other	<ul style="list-style-type: none"> Deviation from normal operation 	Operation circumstances must equal to those it was designed for ¹ .

Problem: Performance

Part	Cause/result	Remedy
Drive unit	<ul style="list-style-type: none"> Wrong frequency 	Check frequency connection.
Agitator	<ul style="list-style-type: none"> Reverse direction 	Inspect the Agitator carefully.
Other	<ul style="list-style-type: none"> Deviation from normal operation 	Operation circumstances must equal to those it was designed for ¹ .

¹ See section *Intended use* on page 15

5.4 Cleaning recommendations

WARNING

Ensure the drain in flange is not clogged up by cleaning drain regularly.

Ensure that all surfaces in contact with product are totally clean in order not to contaminate the product.

Pay special attention to:

- Impeller device surfaces
- Surfaces between impeller devices and shaft
- Surfaces around sealing
- Surfaces around weldings

CAUTION

Mechanical seals are designed for cleaning in place (CIP) and sterilising in place (SIP).

NOTE

Always rinse well with clean water after the cleaning.

5.5 Temperature limits

The highest allowable ambient temperature is 40°C.

For applications without bearing frame (not ATEX):

The highest allowable continuous temperature of the SHAFT that goes into the gear motor is 105°C.

Shorter periods with higher application temperatures, eg. 10-20 minutes during a sterilization phase or the like, can be allowed and accepted without changing the oil service interval and without reducing the lifetime of the gear motor.

If longer periods with exceeded application temperatures are required, the actual temperature of the oil in the gear motor must be measured.

The highest allowable oil temperature is 140°C and the oil service interval, which at 70°C is about 40.000 hours, will be reduced by 50% for each 15K the oil temperature is increased above the 70°C.

For applications with bearing frame (not ATEX):

The highest allowable continuous temperature of the SHAFT that goes into the bearing frame is 105°C.

Shorter periods with higher application temperatures, eg. 10-20 minutes during a sterilization phase or the like, can be allowed and accepted without changing the service interval and without reducing the lifetime of the bearings.

If longer periods with exceeded application temperatures are required, the actual temperature of the bearings must be measured.

The highest allowable bearing temperature, without changing the service interval, is 120°C.

5.6 Pressure limits

The ALS and ALB Agitator can be equipped with different shaft seal types with different operating properties. The shaft seal is selected according to the application.

In below table you will find the maximum allowable tank pressure during operation for the different seal types.

Seal type	Tank pressure (barg)		Designation
	Min.	Max.	
-S1-	-0.5	6.0	Single mechanical shaft seal, High pressure and high speed
-S2-	-0.5		Single mechanical shaft seal, High pressure and high speed
-S3-	-0.5	1.5	Single mechanical shaft seal, High pressure and high speed
-D-	-1.0	4.5 ¹	Double mechanical shaft seal w. flush. Medium pressure and high speed
-DC-	-1.0	6.0	Double mechanical shaft seal w. flush. High pressure and high speed

¹ If the seal faces are submerged, the maximum tank pressure can be increased to 6.0bar(g).

NOTE

Above pressures are not taking limitations on flange connections according to local pressure regulations into consideration.

Be aware that the operating pressure limits for the shaft seal can be lower than the tank design pressure.

6 Maintenance

6.1 General maintenance

NOTE

Read the instructions carefully.

The items refer to the parts lists in section

For maintenance instructions from suppliers, see chapter [Appendix](#) on page 89.

Always ensure that mounting is according to chapter [Technical Data](#) on page 67.

Ensure totally clean surfaces during mounting - also remove remaining loctite residue on threads.

Always refer to tightening torques in section [Tightening torques for bolt connections](#) on page 71.

All scrap must be stored/disposed of in accordance with current rules and directives.

Always use original Alfa Laval spare parts.

WARNING

If possible, always dismantle the Agitator from tank before dismantling it.

For lifting instruction, please refer to chapter [Installation](#) on page 17.



WARNING

Maintenance of the Agitator should only be performed by authorized personnel.

Always read the [Technical Data](#) on page 67 thoroughly.

Always ensure that the mounting is according to Agitator described in section [Intended use](#) on page 15 and chapter [Technical Data](#) on page 67.

Always disconnect the power supply when servicing the Agitator.

Always use proper tools.

Always replace worn sealing elements before reassembling.

Follow the dismantling and assembly instructions to the letter.

After maintenance, section [Pre-use check](#) on page 31 must be read thoroughly before operation.

6.1.1 Preventive maintenance

To ensure that your Alfa Laval machine operates efficiently, it is essential to follow a simple preventive maintenance programme, which will keep your machine in good working conditions. Good maintenance requires careful attention at regular intervals!

The following recommended preventive maintenance procedures are based on the average operating conditions of most Alfa Laval machines. However, you will appreciate that a machine, which is subject to rough and dirty conditions, will need more frequent attention than one working in ideal conditions. We trust that you will adjust your maintenance programme to meet the demands of your normal operating conditions.

Sealing

	Replace every:				
	500 hour or yearly	1000 hour or yearly	3000 hour or yearly	6000 hour or every 3rd year	10000 hour or every 3rd year
Mechanical seal					
• NOT flushed: S1, S2, S3				x	
• Flushed: DC, D					x

Bearing frame

	Replace every:				
	500 hour or yearly	1000 hour or yearly	3000 hour or yearly	6000 hour or every 3rd year	10000 hour or every 3rd year
• Spider type coupling (if any)					x
• Static seals					x
• Radial seals			x		
• Bearings, rpm < 700					x
• Bearings, rpm > 700				x	

6.2 Replacement of drive unit with bearing frame

- 1 Remove shroud, if any.

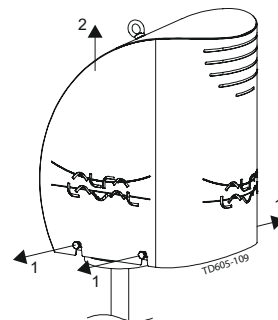

2 Loosen cap nuts.

CAUTION

If dismantling motor from gear:

- Follow supplier instructions
- Ensure that the gear oil is contained.
- A cog wheel may be mounted onto the motor shaft.

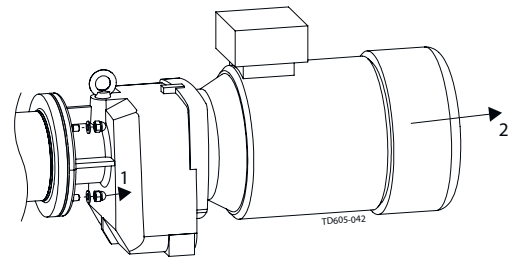

3 Release the gear motor from the Agitator.

CAUTION

There is a spider type coupling mounted onto the gear motor shaft.

4 Lift up the drive unit and pull it away.

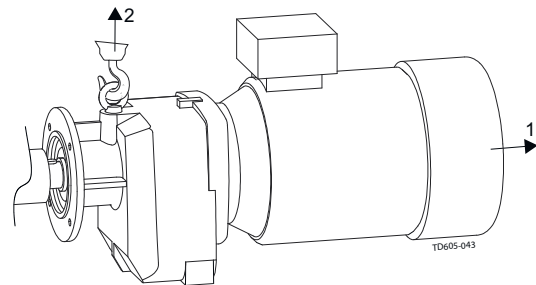

- 5
1. Loosen coupling screws.
 2. Pull the coupling of the gear motor shaft.

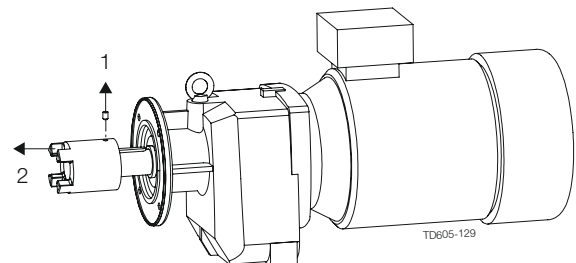

6 Replace drive unit.

Mount coupling.

NOTE

Coupling part can be heated to 80-120°C for easier mounting onto gear motor shaft.

CAUTION

Ensure that the axial position of the coupling is according to illustration. The value XX is to be found in section [Spider coupling](#) on page 73.

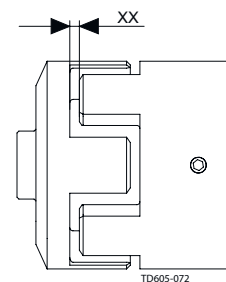

- 7 Replace spider if necessary.
 Use Loctite® 243 before fastening screws.
 Always refer to tightening torques in section [General technical data](#) on page 67 when tightening bolts.

- 8 Mount drive unit reverse as dismantling.

6.3 Replacement of drive unit (without bearing frame)

- 1 Remove shroud, if any.

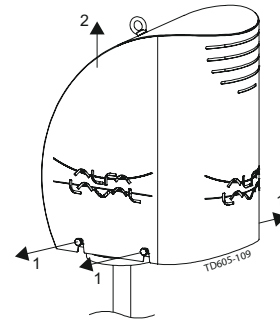

- 2
1. Dismantle Agitator from welding flange.
 2. Lift up Agitator.

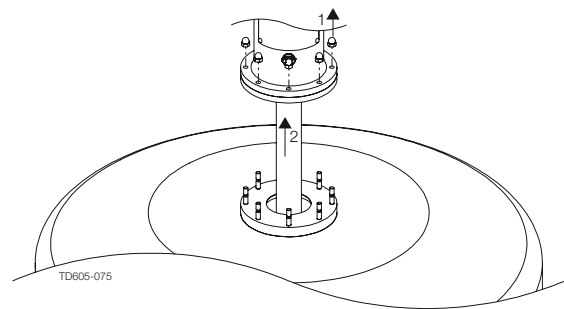

- 3 Before dismantling drive unit, please see instructions in [Replacement of shaft seal, type D](#) on page 55 and [Replacement of shaft seal, type S3](#) on page 64, depending on seal type.

- 4 Loosen cap nuts.



If dismantling motor from gear:

- Follow supplier instructions
- Ensure that the gear oil is contained
- A cog wheel may be mounted onto the motor shaft.

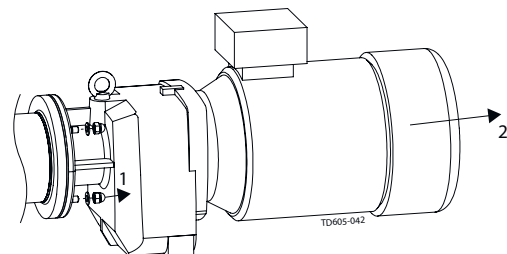

- 5 Release the gear motor from the Agitator.
Refer to supplier instructions.

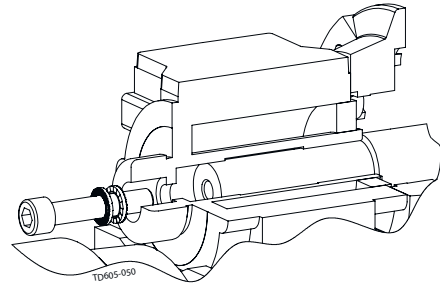

a)



There is a Nord-lock® washer mounted on the gear fastening the shaft.

The washer consists of two parts attached to each other with some silicone as shown on the picture. It is important that the two parts are positioned as shown.

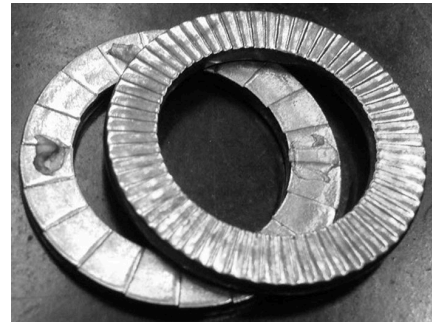

- 6 Lift up the drive unit and pull it away.

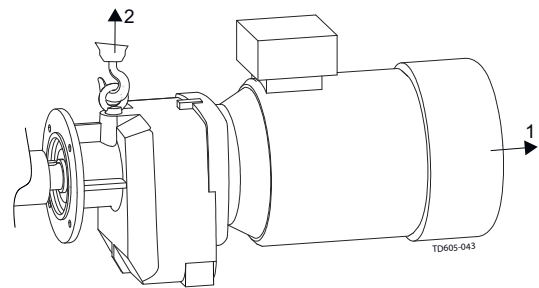

- 7 Replacement drive unit.

- 8 Use Loctite® 243 before fastening screws.

Always refer to tightening torques in section [Tightening torques for bolt connections](#) on page 71.

- 9 Mount drive unit reverse as dismantling.

6.4 Replacement of drive unit (Motor and shaft unit)

- 1 Remove shroud, if any.

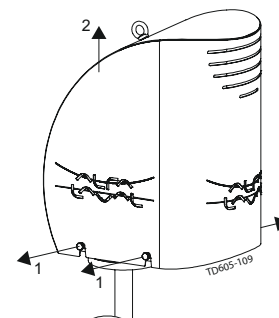

- 2 Loosen cap nuts.

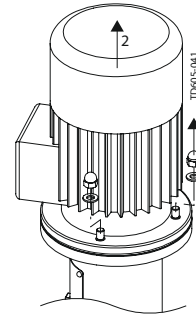

- 3 Release the motor from the Agitator.



Motor and shaft are one complete unit.

- 4 Lift up the drive unit and pull it away.

- 5 Replace drive unit.

- 6 Use Loctite® 243 before fastening screws.

Always refer to tightening torques in section [Tightening torques for bolt connections](#) on page 71.

- 7 Mount drive unit reverse as dismantling.

6.5 Dismantling and mounting shaft (with bearing frame except BC160)

1. Dismantle Agitator from welding flange.
2. Lift up Agitator.

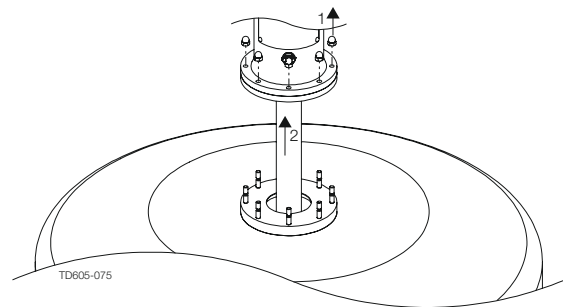

2. 1. Dismantle drive unit as described in section [Replacement of drive unit with bearing frame](#) on page 42.
2. Remove PreVent valve.

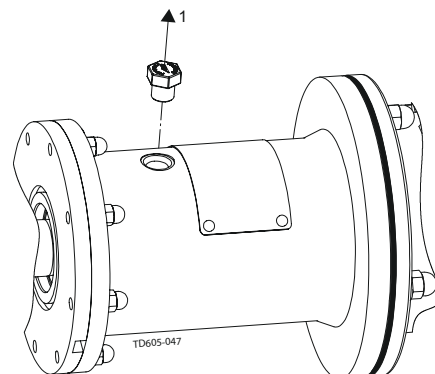

- 3 Looking through the PreVent valve hole, rotate shaft until shaft locking hole aligns.

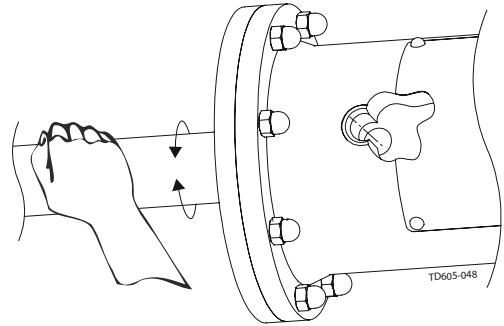

- 4
1. Mount retainer bolt tool for shaft locking.
 2. Remove centre bolt.

NOTE

Extra retainer bolt tool can be acquired if needed (see section [Tools](#) on page 88 or Spare Part Manual).

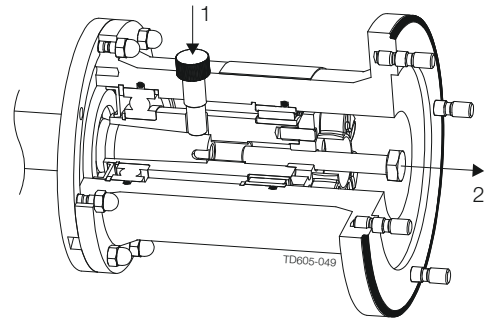

- 5 Remove spider and coupling part.

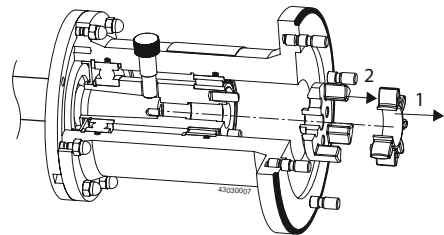

- 6 Dismantle shaft by mounting extractor bolt tool.

Keep turning extractor bolt until shaft is forced from the bearing frame.

NOTE

Extra extractor bolt tool can be acquired if needed (see section [Tools](#) on page 88 or Spare Part Manual).

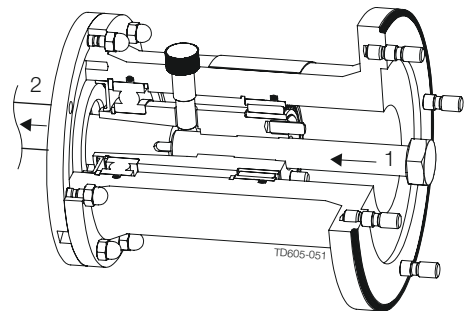

- 7 Mount shaft reverse as dismantling

CAUTION

Ensure that oil trap ring, if any, is refitted correct during mounting.

6.6 Replacement of bearings, type B20, B25, B25/30, B35, B35/40, B45, B45/50, B55, B55/60

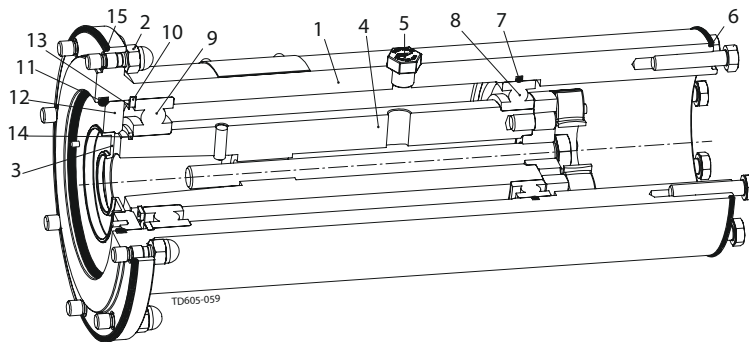

NOTE

Positions referred to in following instructions can be seen in the above illustration.

1. Dismantle shaft as described in section *Dismantling and mounting shaft (with bearing frame except BC160)* on page 46.
2. Remove retainer bolt in step 4 in section *Dismantling and mounting shaft (with bearing frame except BC160)* on page 46.

2.
 1. Remove cap nuts (2).
 2. Remove lantern or mounting flange if no lantern is used from bearing frame.

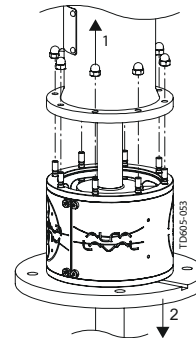

3.
 1. Push cover (12) into bearing frame.
 2. Remove o-ring (11).

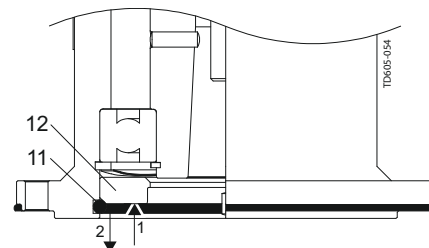

- 4 Remove cover (12) including radial seal (3) and spring (13).

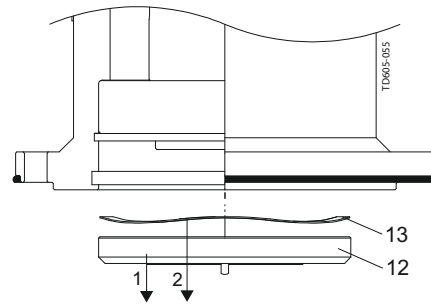

- 5 Remove outer circlip (10) carefully. Use suited pliers.

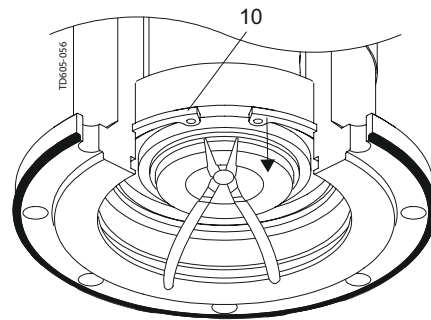

- 6
1. Pull out drive shaft (4) including bearings (8, 9).
 2. Remove o-ring (7)

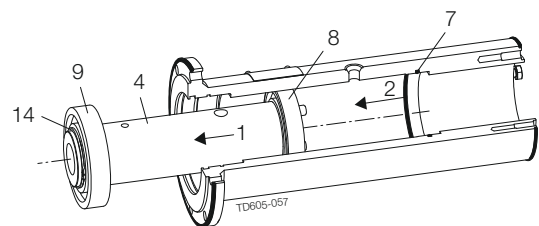

- 7
1. Remove inner circlip (14) carefully. Use suited pliers.
 2. Remove bearings (8, 9).

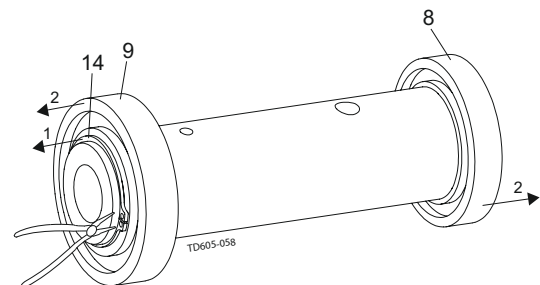

- 8
1. Replace bearings (8, 9) and o-rings (6, 7, 11, 15).
 2. Assembly of bearing frame is reverse as dismantling.

CAUTION

Only apply force to inner bearing rings when mounting bearings on drive shaft.

Only apply force to outer bearing rings when mounting drive shaft with bearings into bearing frame.

6.7 Replacement of bearings, type BC160DH

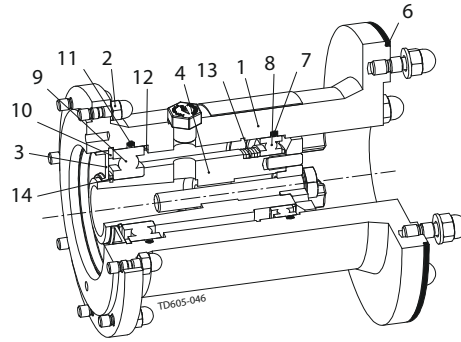

NOTE

Positions referred to in following instructions can be seen in the above illustration.

- 1 Dismantle shaft as described in section *Dismantling and mounting shaft (with bearing frame except BC160)* on page 46.

- 2
 1. Remove cap nuts (2).
 2. Remove lantern or mounting flange if no lantern is used from bearing frame.

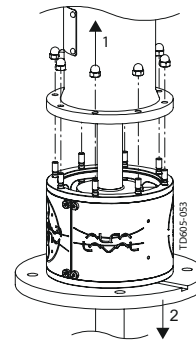

- 3 Remove radial seal (3).

NOTE

Alfa Laval recommends replacing the radial seal.

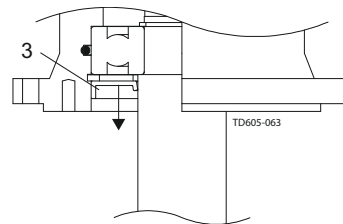

- 4 Remove outer circlip (10) carefully. Use suited pliers.

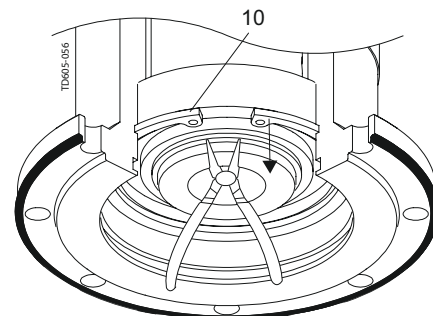

- 5
 1. Pull out drive shaft (4) including bearings (8, 9).
 2. Remove O-rings, (7), (11).

6

1. Remove spring ring (13).
2. Remove inner circlip (14) carefully. Use suited pliers.
3. Remove bearings (8, 9).

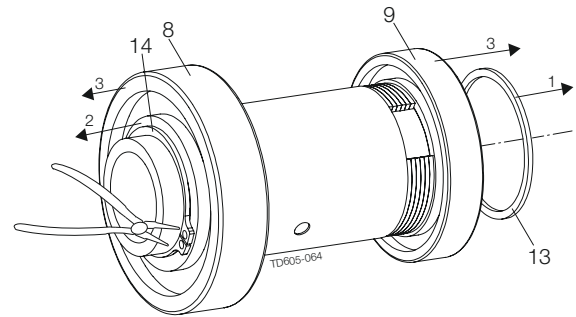

7

1. Replace bearings (8, 9) and o-rings (6, 7, 11).
2. Assembly of bearing frame is reverse as dismantling.

CAUTION

Only apply force to inner bearing rings when mounting bearings on drive shaft.

Only apply force to outer bearing rings when mounting drive shaft with bearings into bearing frame.

6.8 Replacement of bearing, type BC160D

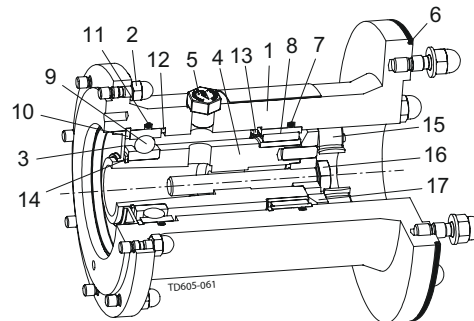

NOTE

Positions referred to in following instructions can be seen in the above illustration.

1

- 1 Dismantle shaft as described in section *Dismantling and mounting shaft (with bearing frame except BC160)* on page 46 .

2

1. Remove cap nuts (2).
2. Remove lantern or mounting flange if no lantern is used from bearing frame

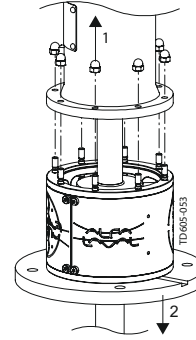

3

3. Remove radial seal (3).

NOTE

Alfa Laval recommends replacing the radial seal.

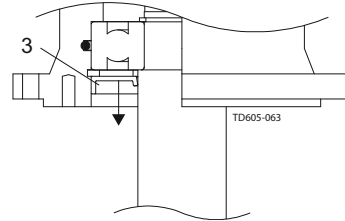

4

4. Remove outer circlip (10) carefully. Use suited pliers.

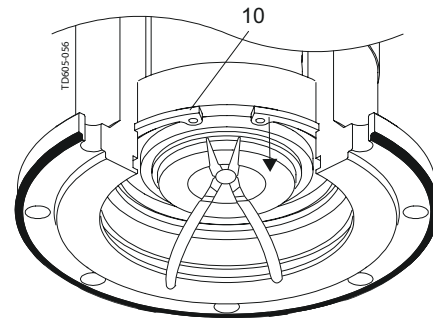

5

1. Pull out drive shaft (4) including bearings (8a, 9).
2. Pull out circlip (12) or let it stay in bearing frame.

NOTE

Outer bearing ring (8b) should stay in bearing frame

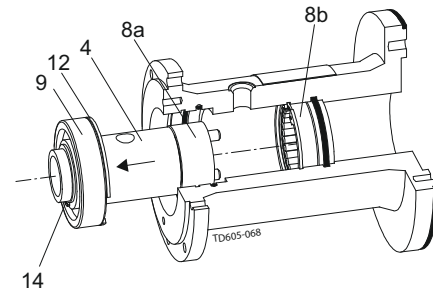

6

1. Remove upper circlip (13) carefully. Use suited pliers
2. Push out, using applicable tool, the outer bearing ring (8b).
3. Remove o-rings (7, 11).

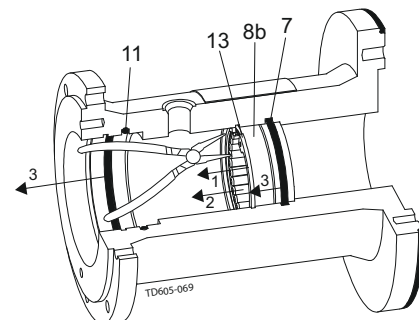

- 7
1. Remove inner circlip (14) carefully. Use suited pliers.
 2. Remove bearings (8a, 9)

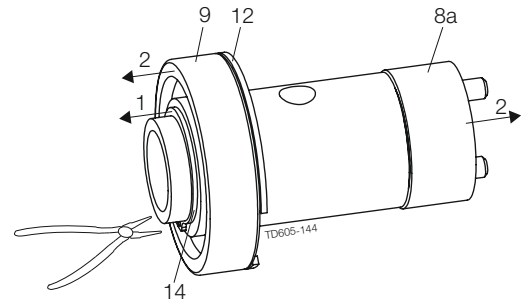

- 8
1. Replace bearings (8a, 8b), (9) and o-rings (6, 7, 11).
 2. Assembly of bearing frame is reverse as dismantling.

CAUTION

Only apply force to inner bearing rings when mounting bearings on drive shaft.

Only apply force to outer bearing rings when mounting drive shaft with bearings into bearing frame.

6.9 Replacement of bearings type BC160

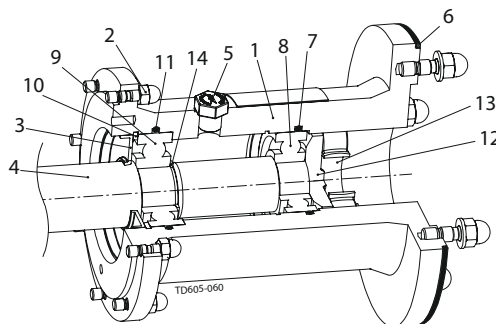

NOTE

Positions referred to in following instructions can be seen in the above illustration.

- 1
1. Dismantle drive unit as described in section [Replacement of drive unit with bearing frame](#) on page 42.

2

1. Remove cap nuts (2).
2. Remove lantern or mounting flange if no lantern is used from bearing frame.

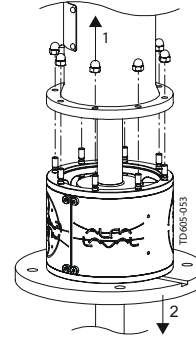

3

3. Remove radial seal (3).



Alfa Laval recommends replacing the radial seal.

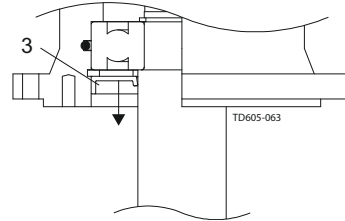

4

4. Remove outer circlip (10) carefully. Use suited pliers.

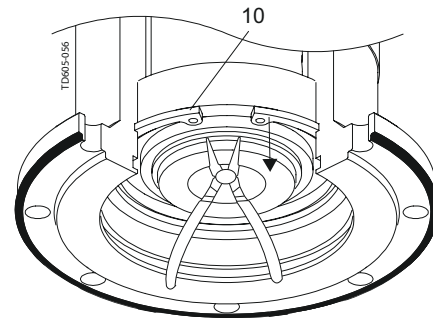

5

1. Pull out shaft (4) including bearings (8, 9).
2. Remove o-rings (7, 11).

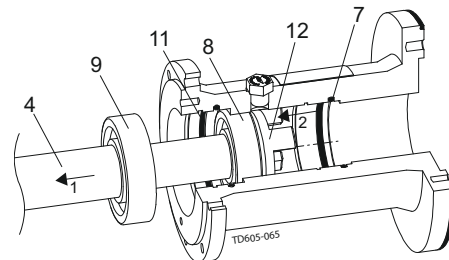

6

1. Secure shaft (4), without causing surface damage to it.
2. Remove coupling (12) by turning it the opposite direction indicated by arrow on nameplate.

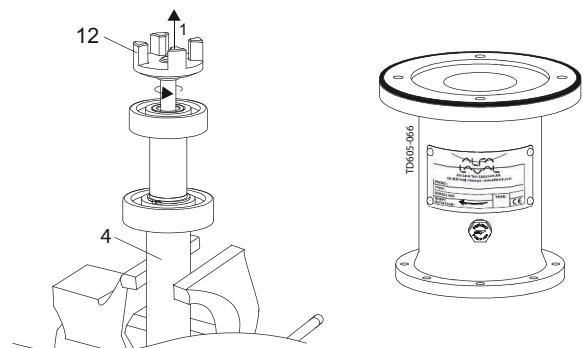

7

1. Remove bearing (8).
2. Remove inner circlip (14) carefully. Use suited pliers.
3. Remove bearing (9).

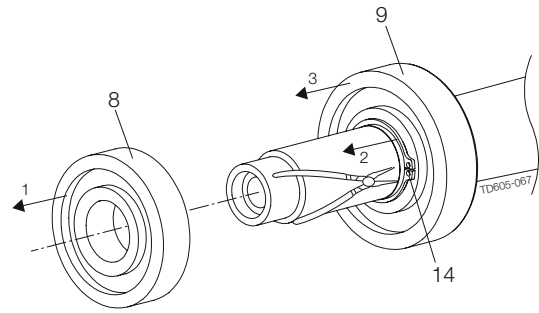

8

1. Replace bearings (8, 9) and o-rings (6, 7, 11).
2. Assembly of bearing frame is reverse as dismantling.

CAUTION

Only apply force to inner bearing rings when mounting bearings on drive shaft.

6.10 Replacement of shaft seal, type D

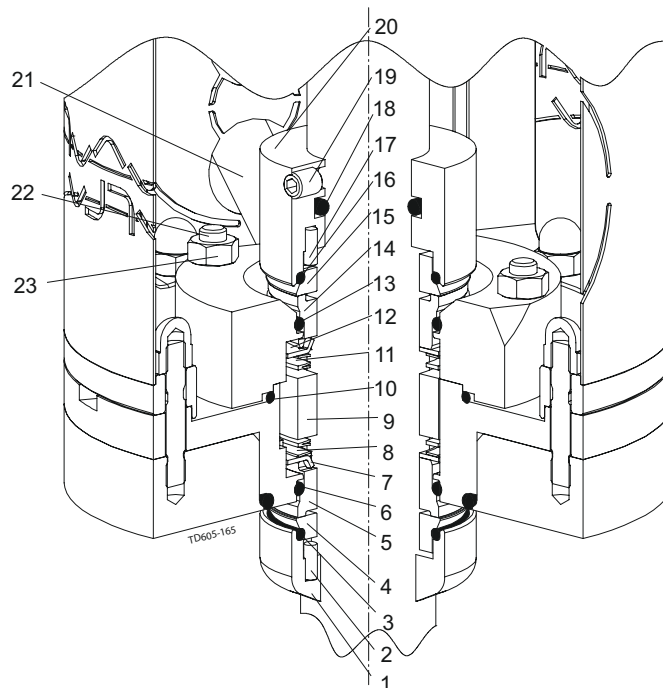

NOTE

To replace seals easier, use detergent.

Ensure subsequent to seal replacement, that all seal faces are totally clean, using alcohol.

Positions referred to in following instructions can be seen in the above illustration.

If possible, **always** dismantle the Agitator from the tank before dismantling any parts.

1. Dismantle Agitator from welding flange.
2. Lift up Agitator

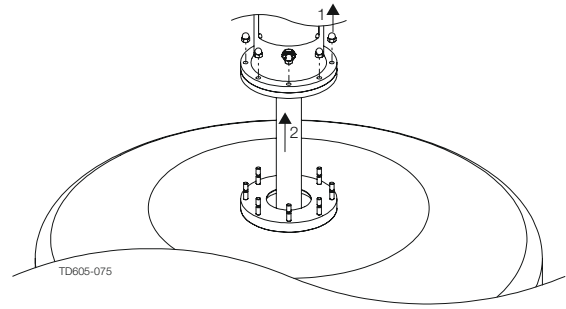

1. Remove flush connections (21).
2. Remove guards from lantern.

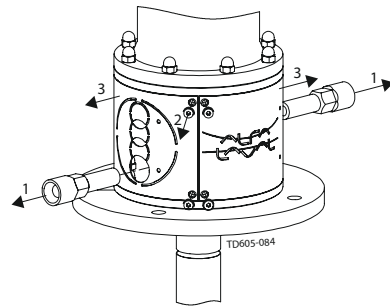

3. Move oil trap ring and o-rings, if any, along the shaft.

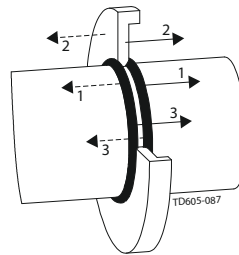

1. Loosen pointed screw (19).
2. Move the rotary seal housing (20) and rotary seal part (15, 16, 18) carefully along the shaft.

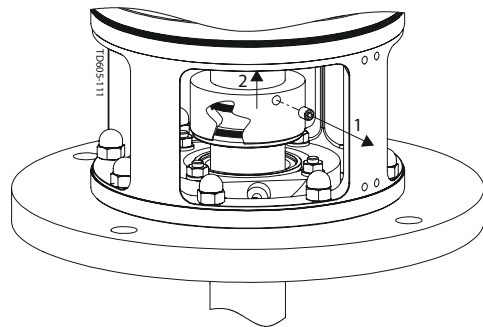

5. Dismantle drive unit as described in section [Replacement of drive unit with bearing frame](#) on page 42.

6

1. Dismantle shaft as described in section *Replacement of drive unit (without bearing frame)* on page 44 or *Dismantling and mounting shaft (with bearing frame except BC160)* on page 46, depending on actual agitator type.
2. Remove shaft and rotary seal parts (3, 4) carefully, avoiding contact.

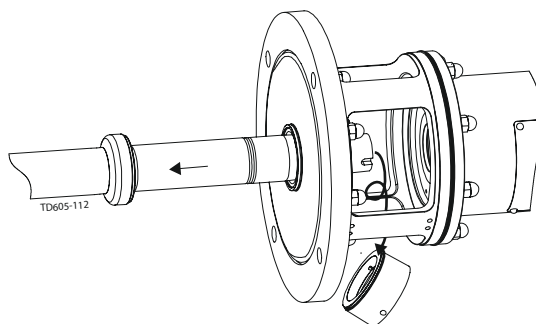

CAUTION

Ensure rotary seal housing and rotary seal part do **NOT** fall when shaft is removed.

7

1. Remove nuts (23) and washers, securing stationary seal housing.
2. Remove stationary seal housing.

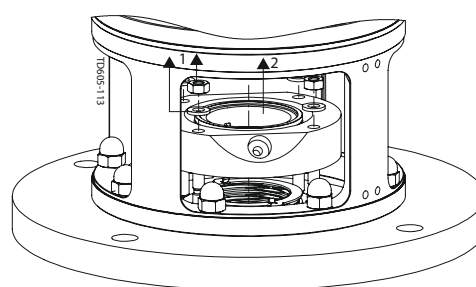

8

1. Replace all seal parts.
2. Assemble Agitator reverse as dismantling.

CAUTION

Ensure clearance between rotary and stationary seal housing is 2.75 mm.

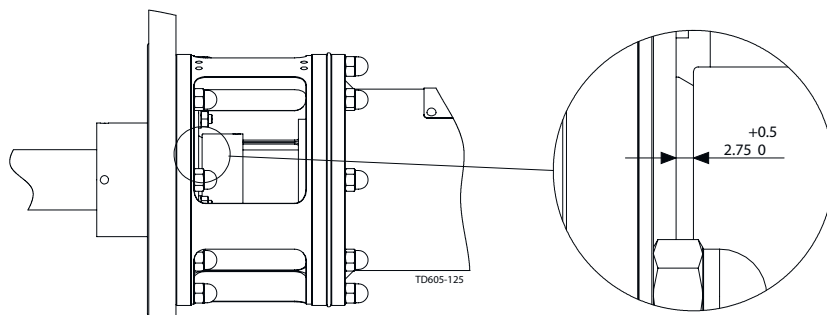

6.11 Replacement of shaft seal, type DC

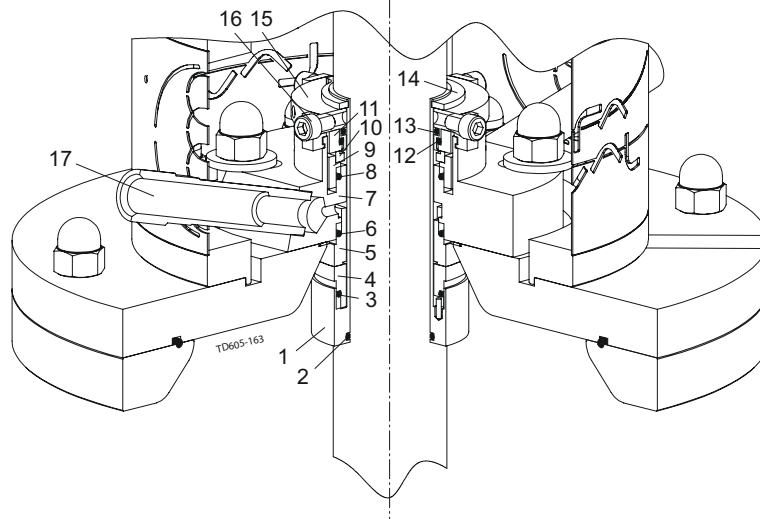

NOTE

To replace seals easier, use detergent.

Ensure subsequent to seal replacement, that all seal faces are totally clean, using alcohol.

Positions referred to in following instructions can be seen in the above illustration.

1. Dismantle Agitator from welding flange.
2. Lift up Agitator.

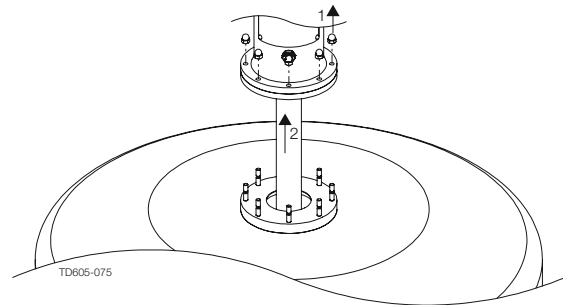

2. Remove flush connections (17).
2. Remove guards from lantern.

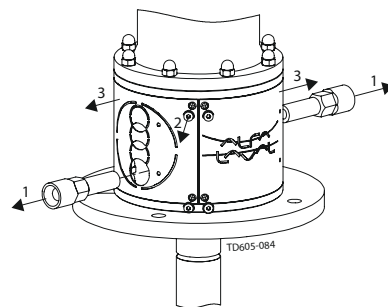

- 3**
1. Rotate distance pieces as shown in step 10.
 2. Loosen pointed screws (the pointed screws are not the screws that fasten the distance pieces).
 3. Loosen cap nut, securing the seal
 4. Ensure the seal can move along the shaft (up to 10 mm).

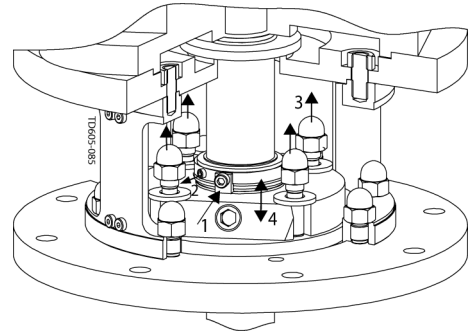

- 4** Move oil trap ring and o-rings, if any, along the shaft.

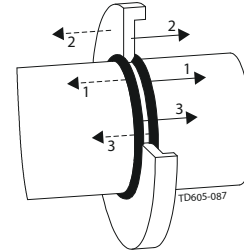

- 5** Remove cap nuts, securing mounting flange.

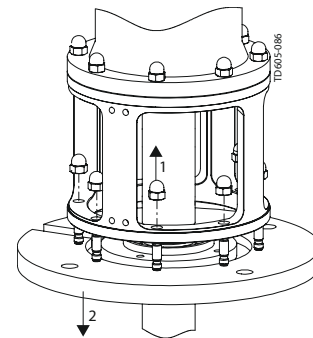

- 6** Dismantle shaft, as described in section [Replacement of drive unit \(without bearing frame\)](#) on page 44 or [Dismantling and mounting shaft \(with bearing frame except BC160\)](#) on page 46 depending on agitator type and carefully remove lantern.

- 7** Lift lantern and drive unit flange.

- 8** Remove DC seal.

- 9**
1. Replace sealing.
 2. Assemble Agitator reverse as dismantling.

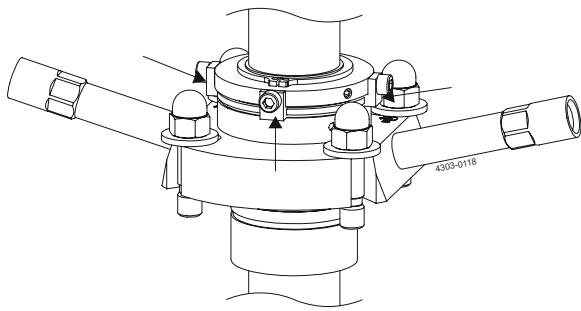

During mounting / dismounting

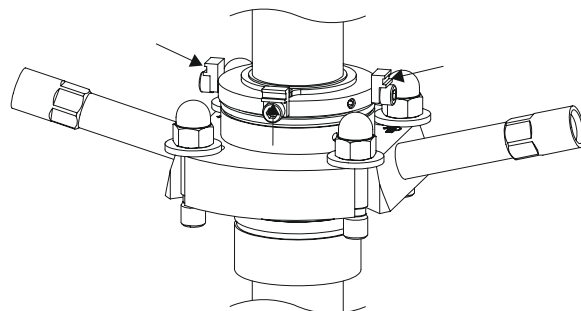

Before start

NOTE

Ensure distance pieces are oriented correctly during mounting or dismounting.

6.12 Replacement of shaft seal, type S1

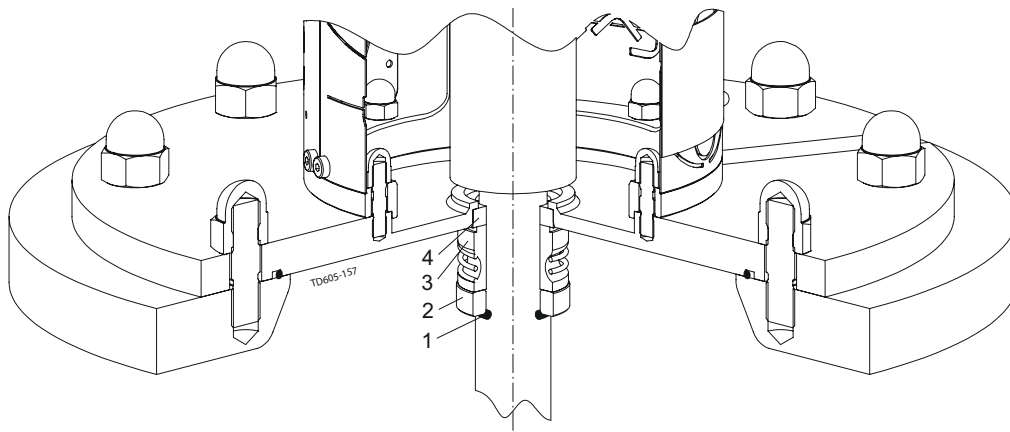

NOTE

To replace seals easier, use detergent.

Ensure subsequent to seal replacement, that all seal faces are totally clean, using alcohol.

If possible, **always** dismantle the Agitator from the tank before dismantling any parts.

Positions referred to in following instructions can be seen in the above illustration.

1. Dismantle Agitator from welding flange.
2. Lift up Agitator.

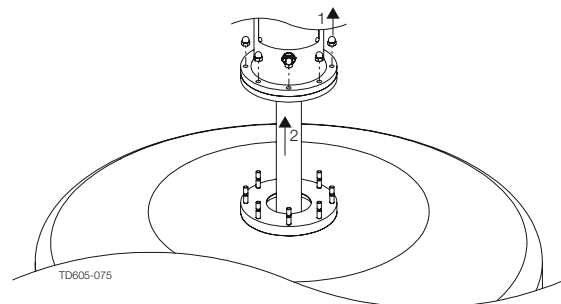

- 2
1. Move o-ring (1) along the shaft.
 2. Move counter ring (2) along the shaft.
 3. Move rotary seal ring (3) along the shaft.

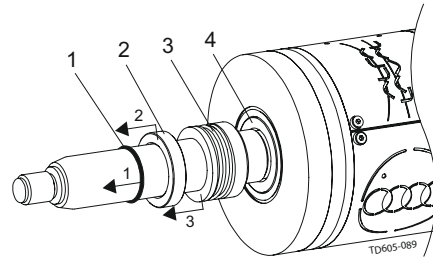

- 3
1. Remove guards from lantern if lantern is used.

- 4
1. Remove cap nuts (if still here).
 2. Move the mounting flange, including stationary seal ring (4), carefully along the shaft.

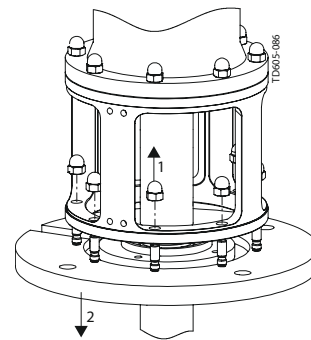

- 5
1. Move oil trap ring and o-rings, if any, along the shaft.

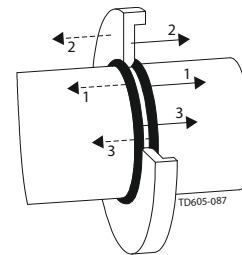

- 6
1. If necessary, dismantle drive unit as described in chapter [Replacement of drive unit with bearing frame](#) on page 42.

- 7
1. Push stationary seal ring (4) out of the mounting flange.

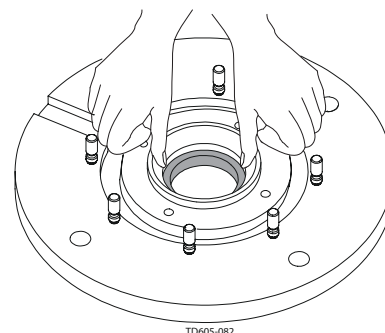

- 8
1. Remove all seal parts from shaft.

- 9
1. Replace all seal parts.
 2. Assemble Agitator reverse as dismantling.

6.13 Replacement of shaft seal, type S2

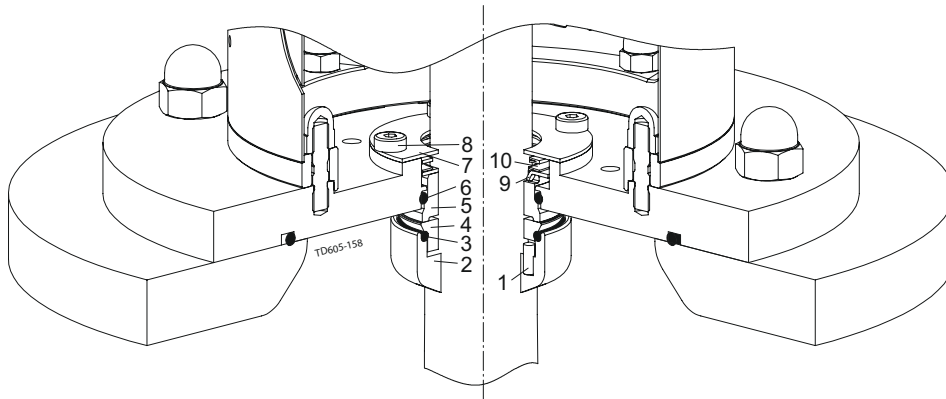

NOTE

To replace seals easier, use detergent.

Ensure subsequent to seal replacement, that all seal faces are totally clean, using alcohol.

If possible, **always** dismantle the Agitator from the tank before dismantling any parts.

Positions referred to in following instructions can be seen in the above illustration.

1. Dismantle Agitator from welding flange.
2. Lift up Agitator

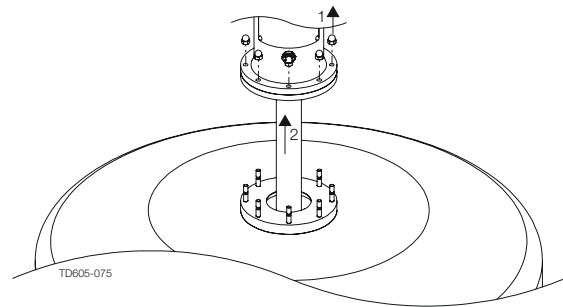

2. Remove guards from lantern if lantern is used.

3. Move oil trap ring and o-rings, if any, along the shaft.

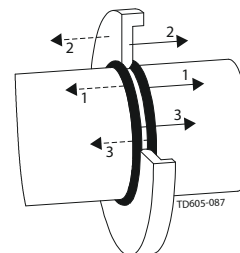

4. Remove carefully the shaft without dismantling drive unit.

5. Remove rotary seal part from shaft.

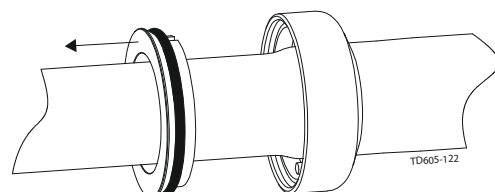

- 6** Remove stationary seal part and o-ring from mounting flange.

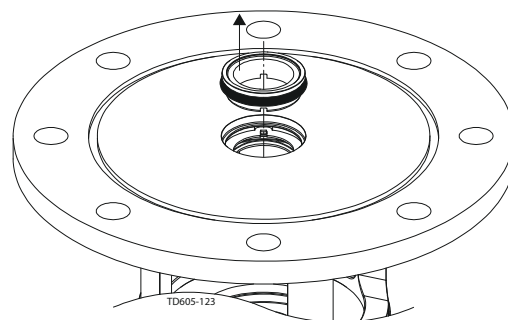

- 7**
1. Remove screws.
 2. Remove retainer ring.
 3. Remove spring and stationary drive ring.

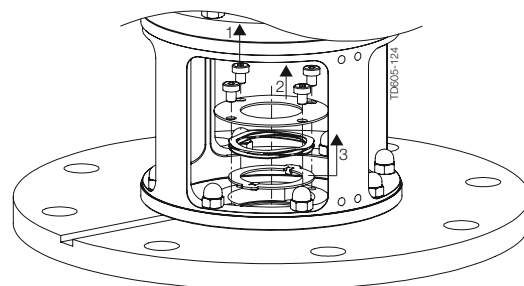

- 8**
1. Replace all seal parts.
 2. Assemble Agitator reverse as dismantling.

6.14 Replacement of shaft seal, type S3

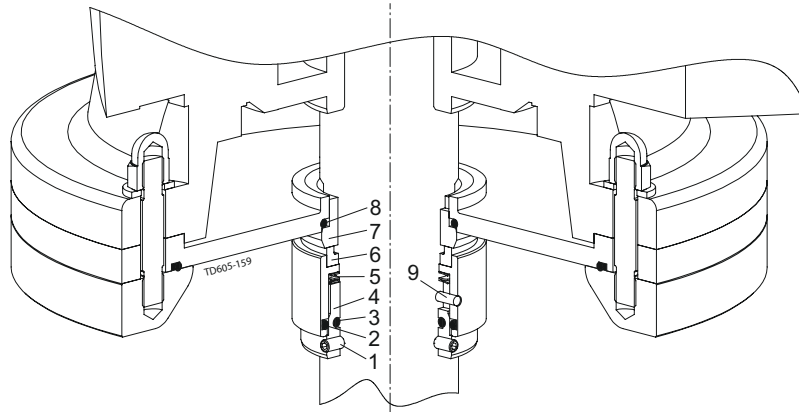

NOTE

To replace seals easier, use detergent.

Ensure subsequent to seal replacement, that all seal faces are totally clean, using alcohol.

If possible, **always** dismantle the Agitator from the tank before dismantling any parts.

Positions referred to in following instructions can be seen in the above illustration.

1. Dismantle Agitator from welding flange.
2. Lift up Agitator.

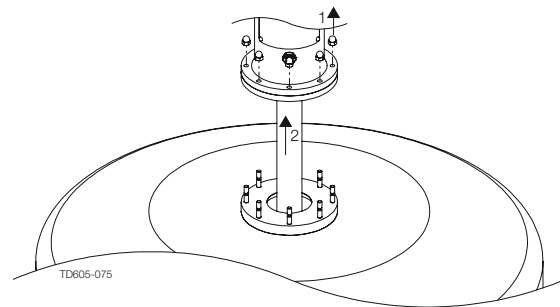

2. Loosen pointed screws (1), securing rotary seal housing onto the shaft.
3. Move the seal housing, including rotary seal part, by pulling it carefully along the shaft, avoiding contact.

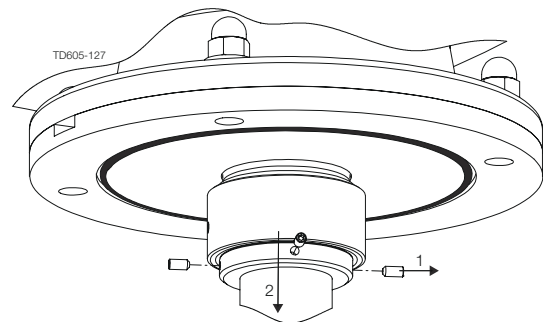

NOTE

Use mild detergent to reduce friction.

3

1. Remove guards from lantern.
2. Remover cap nuts.
3. Move the mounting flange, including stationary seal ring, carefully along the shaft, avoiding contact.

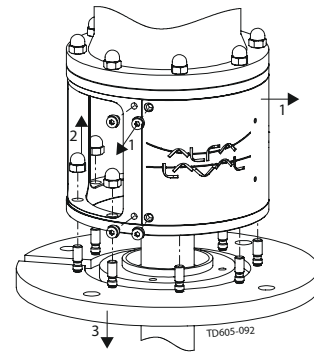

4

4. Move oil trap ring and o-rings, if any, along the shaft.

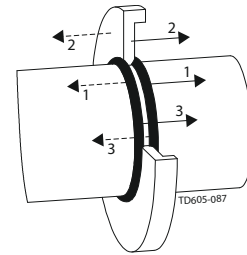

5

5. Push stationary seal ring (7) out of the mounting flange.

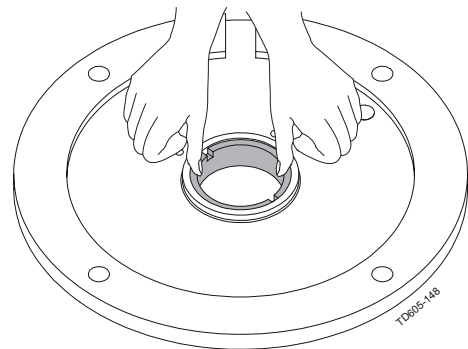

6

6. Remove all seal parts from shaft.

7

1. Replace all seal parts.
2. Assemble Agitator reverse as dismantling and position the rotating seal element according to measure x.

	Shaft size		
	Ø30	Ø35	Ø40
Measure x	36	36	38

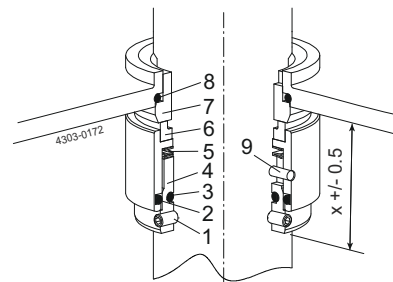

This page is intentionally left blank.

7 Technical Data

NOTE

Technical data must be observed during installation, operation and maintenance.
All personnel should be informed about the technical data.

7.1 General technical data

NOTE

All dimensions in mm unless otherwise stated.

The Alfa Laval Agitator is available in various configurations and is configured to solve the specific application. Therefore, specific information like weight, size, critical oscillation speed and duties can be found in the supplied Alfa Laval quotation agreement.

Important installation information about weight and mounting angle can be found on the supplied Agitator name plate as shown on the illustration.

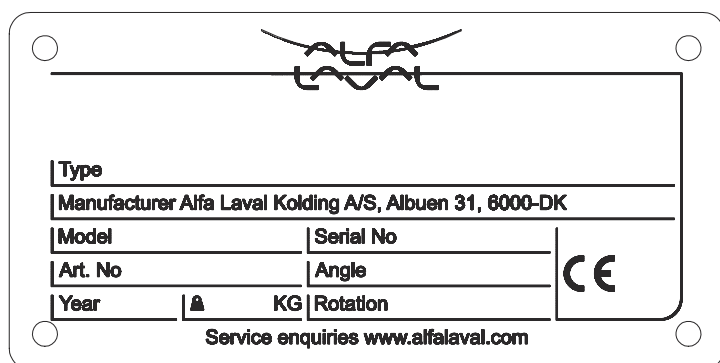

7.2 Mounting angle for side mounted Agitator type ALS

To ensure optimal agitation the side mounted Agitator must be installed in the mounting angle specified on the name plate, as described in the Alfa Laval quotation agreement and as shown in the illustration.

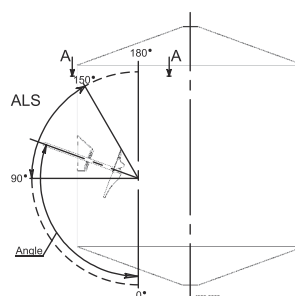

The side mounted Agitator must also be installed in either an offset distance (E) from the center of the tank or it must be installed an offset angle (E*) from the center of the tank as shown on illustration section A-A.

The distance (E) can be calculated as follows:

$$E = C \times \tan(5-7^\circ), \text{ where } C = \text{tank radius}$$

If the offset angle is chosen it must be as follows: $E^* = 5-7^\circ$

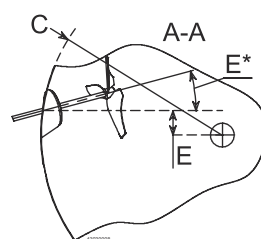

NOTE

In certain cases the offset angle E^* is recommended to be larger - e.g. 10-12°.
- it will be communicated via the Alfa Laval quotation agreement.

7.3 Mounting angle for bottom mounted Agitator type ALB

To ensure optimal agitation the bottom mounted Agitator must be installed in the mounting angle specified on the name plate, as described in the Alfa Laval quotation agreement and as shown on the illustration.

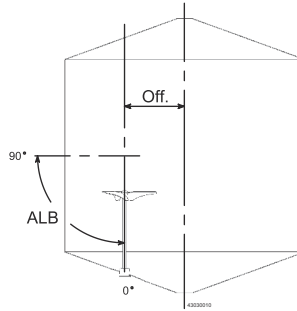

7.4 Connecting flush – Seal type D

Flush connection:

In and out: Male 1/2"-14 BSP (ISO 7/1-Rp)

Flushing pressure: Max. 2.0 bar(g)

Flush media pressure recommendation to prevent flush media contamination by the product media:

(flush media pressure > tank operating pressure)

- Flushing pressure \geq (Tank operating pressure + 0.1 bar)

NOTE

Tank pressure cannot be higher than 1.9 bar(g) due to the maximum flushing pressure. If higher tank pressure is needed the next flush media pressure recommendation must be followed.

Flush media pressure recommendation to prevent product media contamination by the flush media:

(tank operating pressure > flush media pressure)

- Flushing pressure \leq (Tank operating pressure – 0.1 bar)
- (Tank operating pressure – Flushing pressure) \leq 2.5 bar

NOTE

If the tank pressure is more than 2.5 bar(g) greater than the flushing pressure, there will be a risk of dry running on the primary seal faces when the seal faces are not submerged. When the seal faces are submerged there is no limit on the pressure difference during operation.

Flush media flow recommendation:

- Flushing flow rate > 0.25 ltr/min
- Lower flushing flow rate is allowed as long as the temperature difference between in- and outlet is < 10°C

Flush media type recommendation:

- White oils
- Water
- Wet steam
- Alcohol
- Always use appropriately in- and outlet temperatures given for current seal elastomers
- Inlet temperature to be 15°C below actual fluid boiling point (temperature and pressure dependent)
- Always use wet steam (H₂O) if steam is used as flushing fluid
- Inlet temperature ≤ 121°C

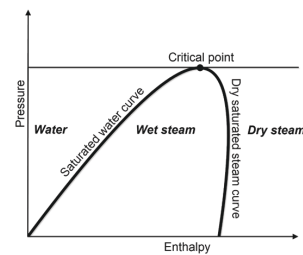

Sterile barrier at seal type D and DC:

- Use a sterile supply system with preferred sterilization temperature and water / wet steam as flush type and ensure that above recommendations are followed.

Ensure flush connections are not installed or oriented in such way that air pockets will appear. In some cases initial air pockets near the seal surfaces (e.g. at bottom mounted agitators ALB) cannot be avoided. It has been tested and verified that an initial flow rate without air at 5 ltr/min lasting for 30 seconds while the agitator is running ensures that all air in seal and flushing chamber will be flushed out.

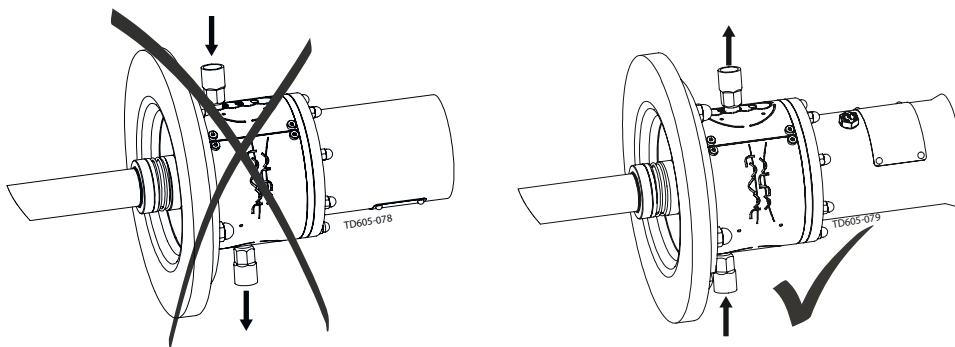

NOTE

Alfa Laval recommends installing a pressure relief valve to ensure pressure never exceed specifications.

Alfa Laval recommends installing a non-return valve onto the inlet connection, to ensure that the seal never runs dry.

If higher flushing pressure is desired, please contact Alfa Laval for advice.

7.5 Connecting flush – Seal type DC

Flush connection:

In and out: Male 1/2"-14 BSP (ISO 7/1-Rp)

Flushing pressure max. 7.0 bar(g)

Flush media pressure recommendation to prevent flush media contamination by the product media:

(flush media pressure > tank operating pressure)

- Flushing pressure \geq (Tank operating pressure + 0.1 bar)

Flush media pressure recommendation to prevent product media contamination by the flush media:

(tank operating pressure > flush media pressure)

- Flushing pressure \leq (Tank operating pressure – 0.1 bar)
- (Tank operating pressure – Flushing pressure) \leq 2.5 bar

NOTE

NOTE If the tank pressure is more than 2.5 bar(g) greater than the flushing pressure, there will be a risk of dry running on the primary seal faces when the seal faces are not submerged. When the seal faces are submerged there is no limit on the pressure difference during operation

Flush media flow recommendation:

- Flushing flow rate > 0.25 ltr/min
- Lower flushing flow rate is allowed as long as the temperature difference between in- and outlet is < 10°C

Flush media type recommendation:

- White oils
- Water
- Wet steam

- Alcohol
- - Always use appropriately in- and outlet temperatures given for current seal elastomers
 - Inlet temperature to be 15°C below actual fluid boiling point (temperature and pressure dependent)
 - Always use wet steam (H₂O) if steam is used as flushing fluid
 - Inlet temperature ≤ 121°C

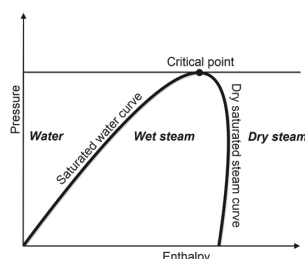

Sterile barrier at seal type D and DC:

- Use a sterile supply system with preferred sterilization temperature and water / wet steam as flush type and ensure that above recommendations are followed

Ensure that connection of outlet and inlet is correct, with regard to Agitator rotation direction! Ensure that the distance pieces (1) on the seal are mounted as shown on illustration.

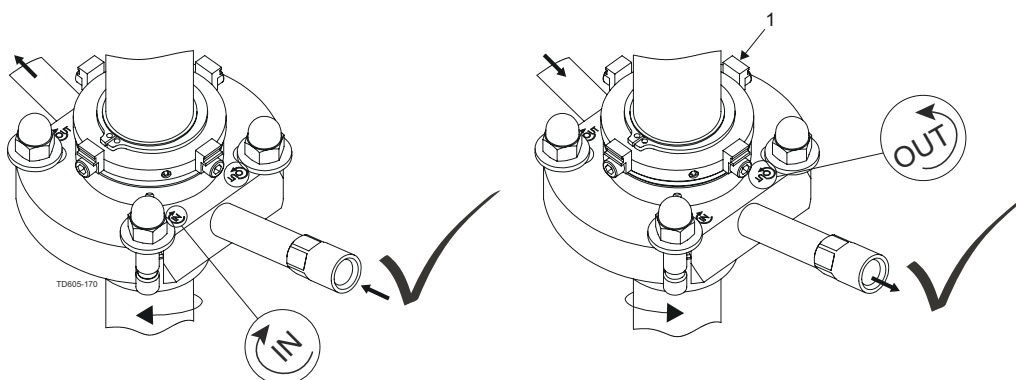

NOTE

Alfa Laval recommends installing a pressure relief valve to ensure pressure never exceed specifications.

Alfa Laval recommends installing a non-return valve onto the inlet connection, to ensure that the seal never runs dry.

If higher flushing pressure is desired, please contact Alfa Laval for advice.

7.6 Tightening torques for bolt connections

CAUTION

Use Loctite® before fastening.

Do **NOT** use air powered tools.

M4	M5	M6	M8	M10	M12	M14	M16	M18	M20	M22	M24
3 Nm	6 Nm	11 Nm	26 Nm	51 Nm	88 Nm	141 Nm	218 Nm	308 Nm	439 Nm	582 Nm	724 Nm

7.7 Shaft alignment

Shaft to be aligned in bearing frame or in gear motor.

RPM up to:	50	100	500	1000	2800
U (max radial tolerance, ALS/ ALB)	0.4	0.3	0.2	0.1	0.05

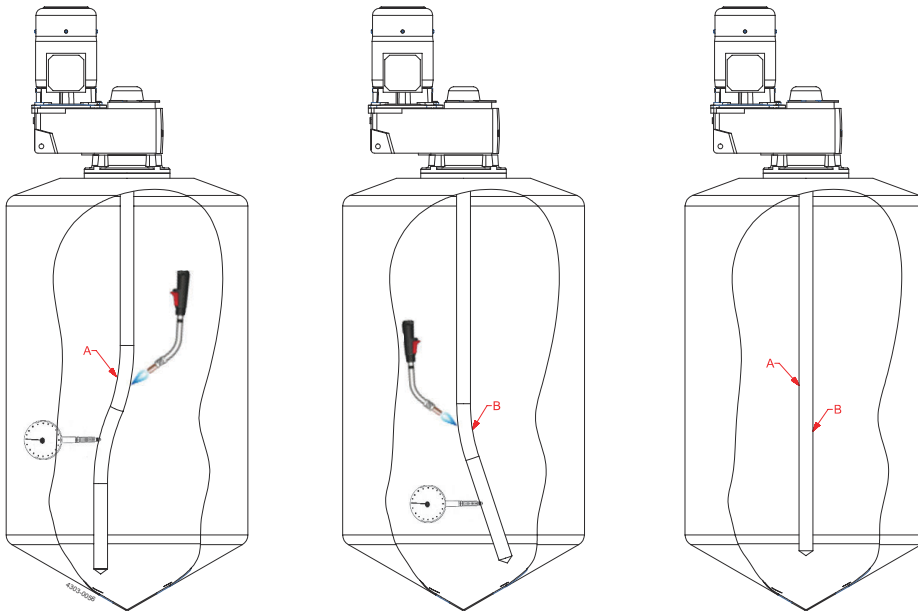
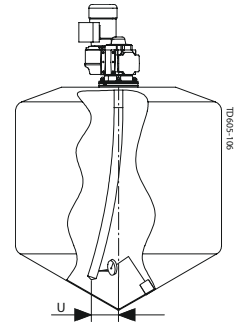

After propellers has been welded onto the shaft and / or two shaft parts has been welded together - the shaft must be aligned. If the shafts has been welded according to Alfa Laval's recommendations shown below – the required alignment will be very little as the amount of introduced heat to the shaft is minimized and due to the fact that all shafts has been aligned before delivery from Alfa Laval.

“All-weld shaft connections and propellers to shaft with one welding seam at a time, cool with air and continue with one welding until welding is according to illustration. Use welding procedures which introduce as less heat, tension and bending to the shaft as possible.”

Required tool:

1. A gas-welding torch supplied with a mixture of Acetylene and Oxygen gas.
2. A dial indicator.

Procedure:

- 1 Alignment of the shaft is carried out in steps from the bearing frame / gear motor and down to the shaft end.
- 2 If the shaft has been exposed to uneven heat around “A” (due to welding of shaft connection or welding of propeller onto shaft) a possible bend can be introduced around “A”.

- 3 The dial indicator is located about 500-2000 mm below “A” (but above the next bend “B”) and the shaft is rotated until the shaft is pointing to the left as shown on the picture.
- 4 The welding torch is used on the opposite site of the bend (the right side of the shaft in this example) about 25-50 mm further up or down from the welding area “A”. The welding torch is positioned very near the shaft surface without moving it and the surface of the shaft is rapidly heated up (1-10 seconds depending on shaft bend) until a Ø2-10 mm red spot is observed. Observing the dial indicator the shaft will, during the heating process, bend even more to the wrong direction but during cooling it bends back to a “more” align position.
- 5 The shaft is cooled down with compressed air until the temperature of the part of the shaft around A is the same as the rest of the shaft and the surrounding temperature (2-10 minutes depending on amount of heat introduced).
- 6 Step 3), 4) and 5) are repeated until the alignment is according the specified “U” (which is a function of speed and agitator type).
- 7 The next position “B” where the shaft has been exposed to uneven heat is located (due to welding of shaft connection or welding of propeller onto shaft).
- 8 The dial indicator is located 500-2000 mm below “B” (but above the next bend) or at the shaft end if the shaft does not have any other bends and the shaft is rotated until the shaft is pointing to the right as shown on the picture.
- 9 The welding torch is used on the opposite site of the bend (the left side of the shaft in this example) about 25-50 mm further up or down from the welding area. The welding torch is positioned very near shaft surface without moving it and the surface of the shaft is rapidly heated up (1-10 seconds depending on shaft bend) until a Ø2-10 mm red spot is observed.
- 10 The shaft is cooled down with compressed air until the temperature of the part of the shaft around A is the same as the rest of the shaft and the surrounding temperature (2-10 minutes depending on amount of heat introduced).
- 11 Step 8), 9) and 10) are repeated until the alignment is according the specified “U” (which is a function of speed and agitator type).
- 12 The spot areas where the shaft has been heated and aligned using the welding torch must be cleaning using chemical pickling and or mechanical abrasive polishing.

7.8 Spider coupling

Axial alignment and tooth thickness [mm]:

	Bearing frame type:				
	BC160/35BC160D/ 30BC160DH/30	B20B25B25/30	B35B35/40	B45B45/50	B55B55/60
X:	2	2	2.5	3	3.5
Ynew:	8.5	8.5	10.9	13.3	17.7
Ymin:	5.6	5.6	7.9	10.3	13.7

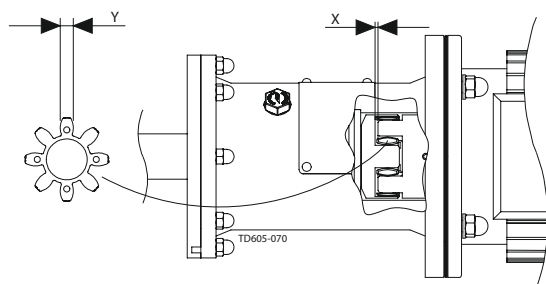
**CAUTION**

During check of spider ensure that all dust is removed before reassembly.

7.9 Storage

Store the Agitator in dry and clean environments.

Rotate shaft every second week to ensure seal faces do not stick together.

8 Parts Lists and Exploded Views

8.1 Agitator main components, drive end

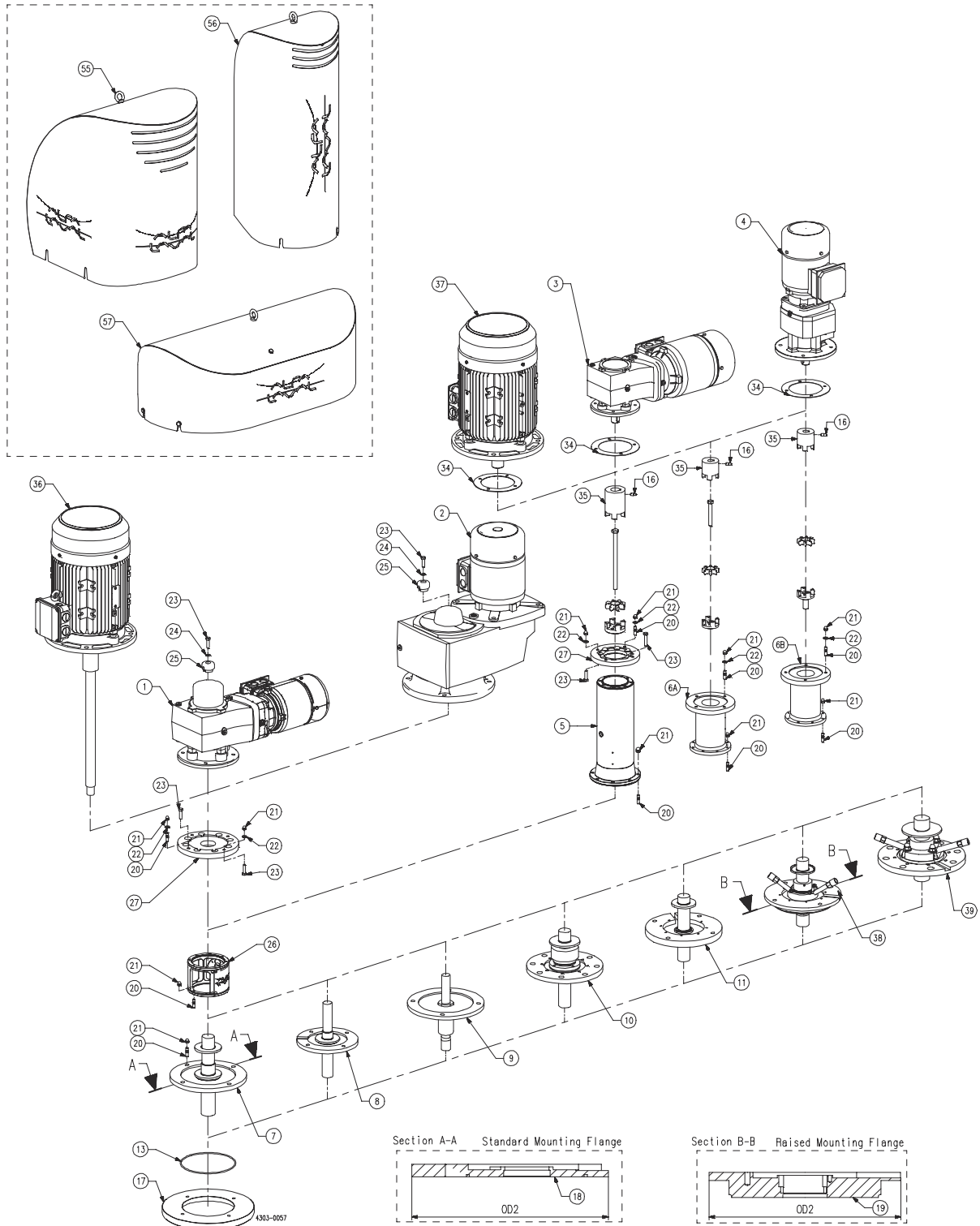

Pos.	Qty.	Denomination
1	1	GR gear motor, hollow shaft
2	1	GR gear motor, hollow shaft
3	1	GR gear motor, output shaft
4	1	GR gear motor, output shaft
5	1	Bearing frame, B20, B25, B25/30, B35, B35/40, B45, B45/50, B55, B55/60
6	1	Bearing frame, BC160/35, BC160D/30, BC160DH/30
7	1	Shaft seal type R
8	1	Shaft seal type G
9	1	Shaft seal type V
10	1	Shaft seal type S
11	1	Shaft seal type S3
13	1	O-ring
16	X ¹⁾	Screw
17	1	Welding flange
18	1	Mounting flange, standard

Pos.	Qty.	Denomination
19	1	Mounting flange, raised
20	X ¹⁾	Stud
21	X ¹⁾	Cap nut
22	X ¹⁾	Washer
23	X ¹⁾	Screw
24	1	Washer, Nord Lock
25	1	Fixing element
26	1	Lantern, complete
27	1	Drive unit flange
34	1	Flat gasket
35	1	Coupling
36	1	Motor and shaft unit
37	1	Motor
38	1	Shaft seal type D
39	1	Shaft seal type DC

 **NOTE**

X Quantity may vary depending on Agitator type. Will be informed upon request.

Find item numbers in the Spare part manual available from the on-line [Alfa Laval product catalogue Anytime](#) or in the [Close at hand spare part catalogue](#).

8.2 Agitator main components, Wet end

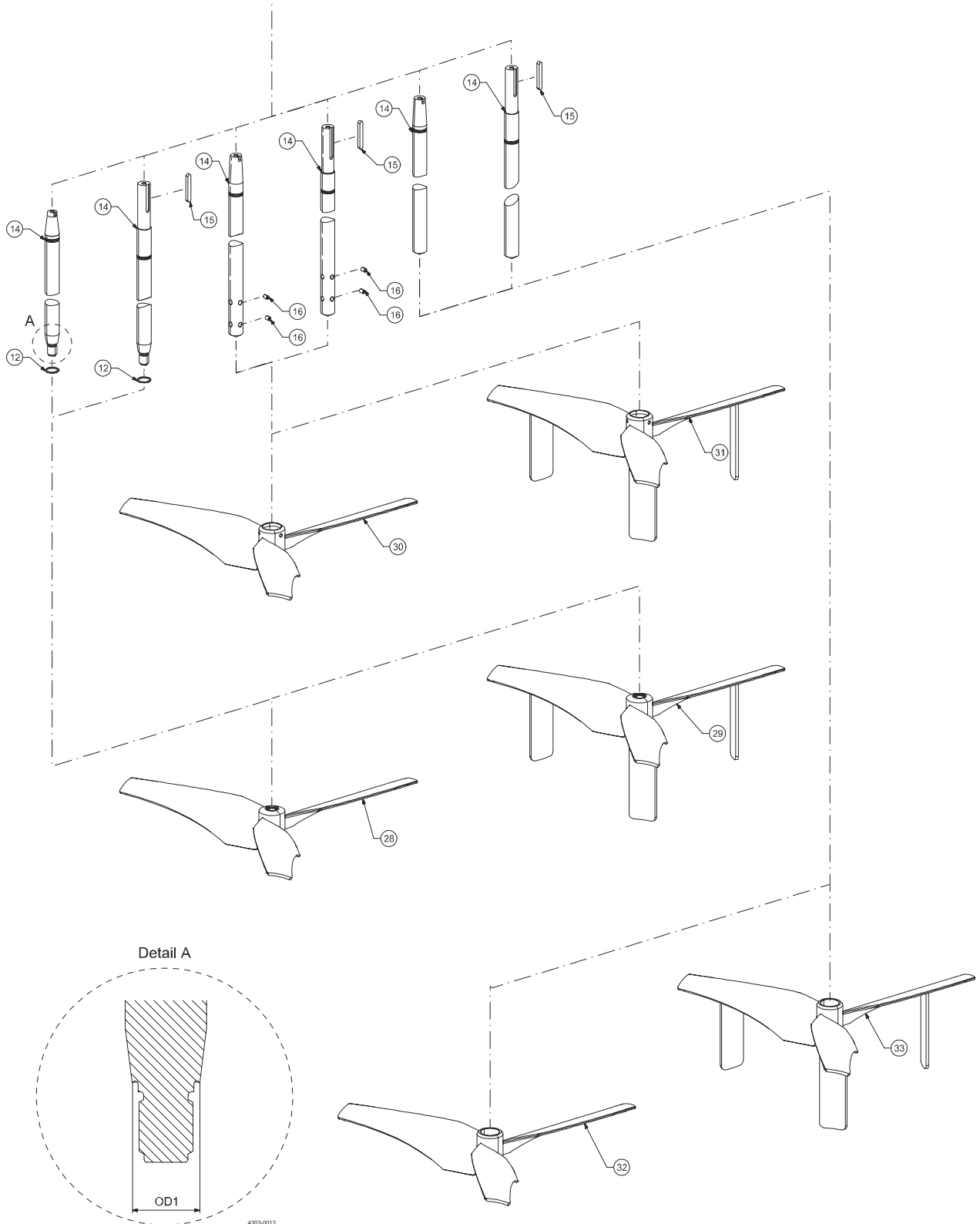

Pos.	Qty.	Denomination
12	1	O-ring
14	1	Shaft
15	1	Parrallel key
16	X	Screw, pointed
28	1	Impeller device, EnSaFoil, (ESF), w. thread
29	1	Impeller device, EnSaFoil Low level, (ESFL), w. thread

Pos.	Qty.	Denomination
30	1	Impeller device, EnSaFoil, (ESF), w. screws
31	1	mpeller device, EnSaFoil Low level, (ESFL), w. screws
32	1	Impeller device, EnSaFoil, (ESF), welding
33	1	Impeller device, EnSaFoil Low level, (ESFL), welding

 **NOTE**

X Quantity may vary depending on Agitator type. Will be informed upon request.

Find item numbers in the Spare part manual available from the on-line [Alfa Laval product catalogue Anytime](#) or in the [Close at hand spare part catalogue](#).

8.3 Bearing frame, B20, B25, B25/30, B35, B35/40, B45, B45/50, B55, B55/60

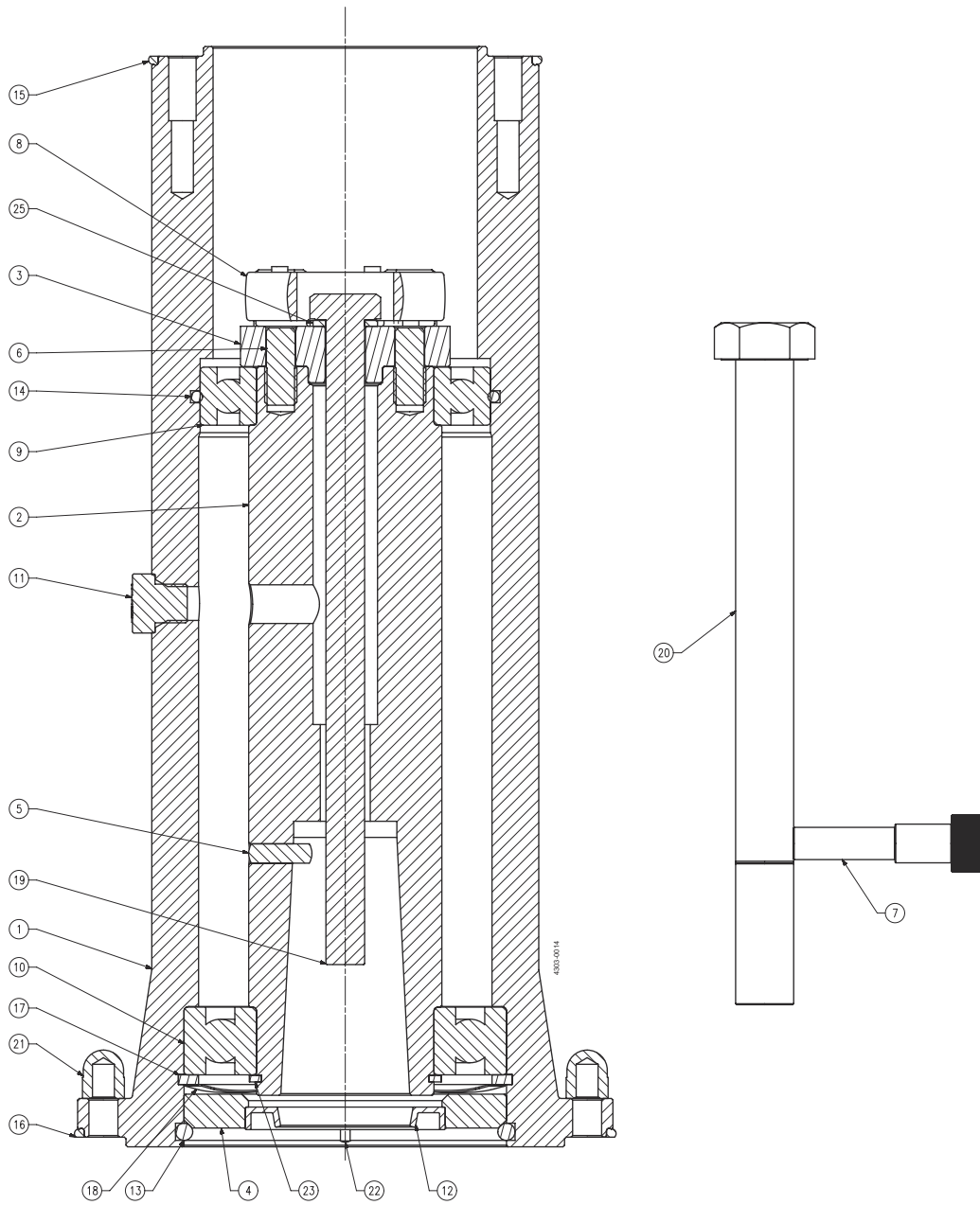

Pos.	Qty.	Denomination
1	1	Bearing frame - housing
2	1	Drive shaft
3	1	Coupling
4	1	Cover
5	1	Pin
6	2	Pin
7	1	Tool, retainer bolt
8	1	Spider
9	1	Bearing
10	1	Bearing
11	1	PreVent Valve
12	1	Seal, radial

Pos.	Qty.	Denomination
13	1	O-ring
14	1	O-ring
15	1	O-ring
16	1	O-ring
17	1	Circlip, inner
18	1	Spring, wave
19	1	Screw
20	1	Extractor bolt
21	8	Cap nut
22	2	Pin
23	1	Circlip, outer
25	1	Washer

 **NOTE**

Find item numbers in the Spare part manual available from the on-line [Alfa Laval product catalogue Anytime](#) or in the [Close at hand spare part catalogue](#).

8.4 Bearing frame BC160/35, BC160D/30, BC160DH/30

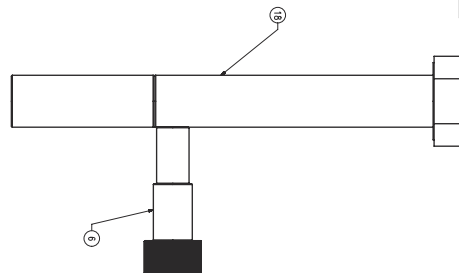
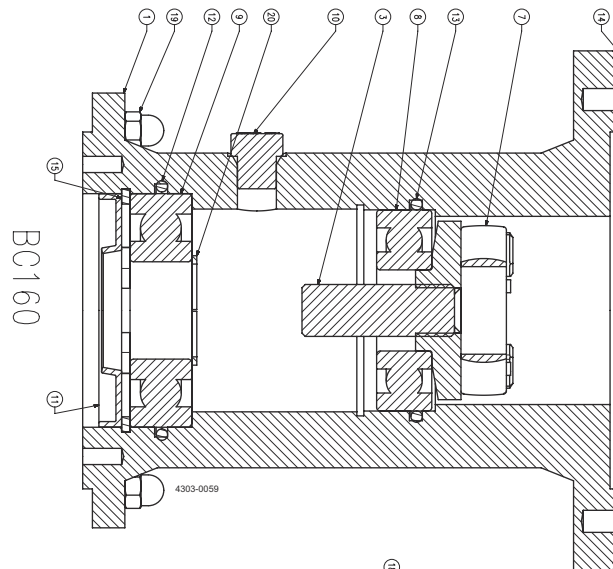
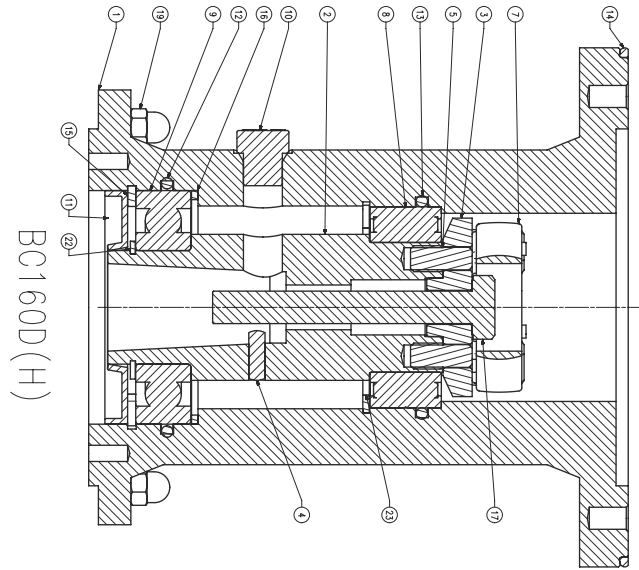

Pos.	Qty.	Denomination
1	1	Bearing frame - housing
2	1	Drive shaft
3	1	Coupling
4	1	Pin
5	2	Pin
6	1	Tool, retainer bolt
7	1	Spider
8	1	Bearing
9	1	Bearing
10	1	PreVent Valve
11	1	Seal, radial

Pos.	Qty.	Denomination
12	1	O-ring
13	1	O-ring
14	1	O-ring
15	1	Circlip, inner
16	1	Seeger ring
17	1	Screw
18	1	Extractor bolt
19	8	Cap nut
20	2	Circlip, outer
22	1	Circlip, outer
23	1	Circlip, inner

 **NOTE**

Find item numbers in the Spare part manual available from the on-line [Alfa Laval product catalogue Anytime](#) or in the [Close at hand spare part catalogue](#).

8.5 Shaft seal, type D

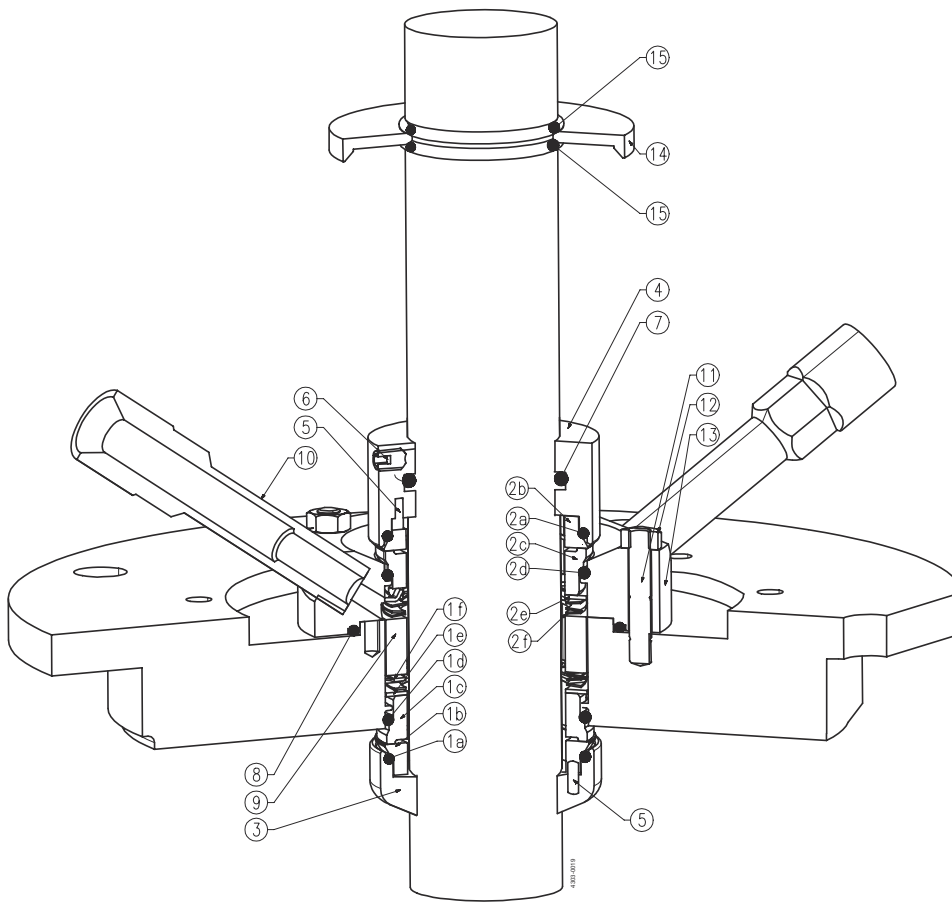

Pos.	Qty.	Denomination
1	1	Seal
2	1	Seal
3	1	Ring, counter ¹
4	1	Ring, counter
5	4	Pin
6	1	Screw
7	1	O-ring
8	1	O-ring

Pos.	Qty.	Denomination
9	1	Spacer
10	2	Flush, connection ½"-14 BSP
11	4	Stud
12	4	Nut
13	1	Seal housing
14	1	Oil trap
15	2	O-ring

¹ Welded onto shaft - maintenance must be carried out by Alfa Laval.

NOTE

Find item numbers in the Spare part manual available from the on-line [Alfa Laval product catalogue Anytime](#) or in the [Close at hand spare part catalogue](#).

8.6 Shaft seal, type DC

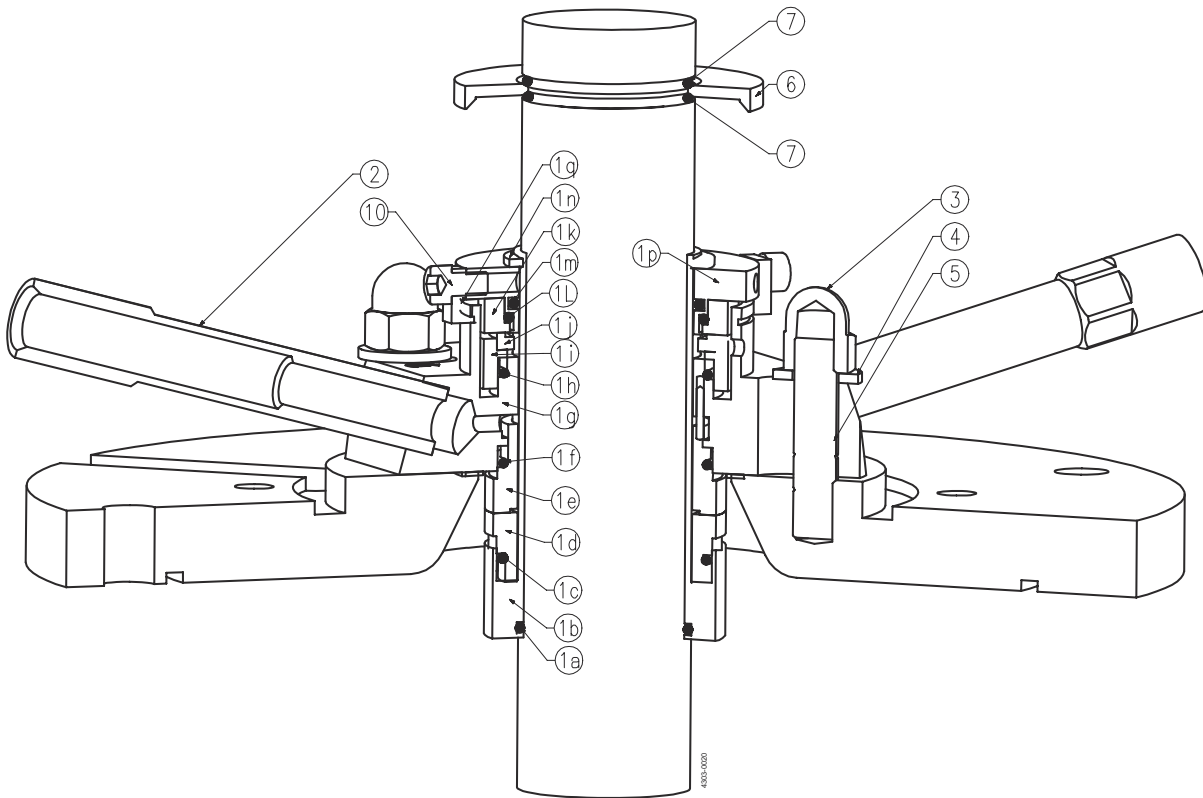

Pos.	Qty.	Denomination
1	1	DC seal
2	2	Flush
3	4	Cap nut
4	4	Washer

Pos.	Qty.	Denomination
5	4	Stud
6	1	Oil trap
7	2	O-ring

NOTE

Find item numbers in the Spare part manual available from the on-line [Alfa Laval product catalogue Anytime](#) or in the [Close at hand spare part catalogue](#).

8.7 Shaft seal, type S1

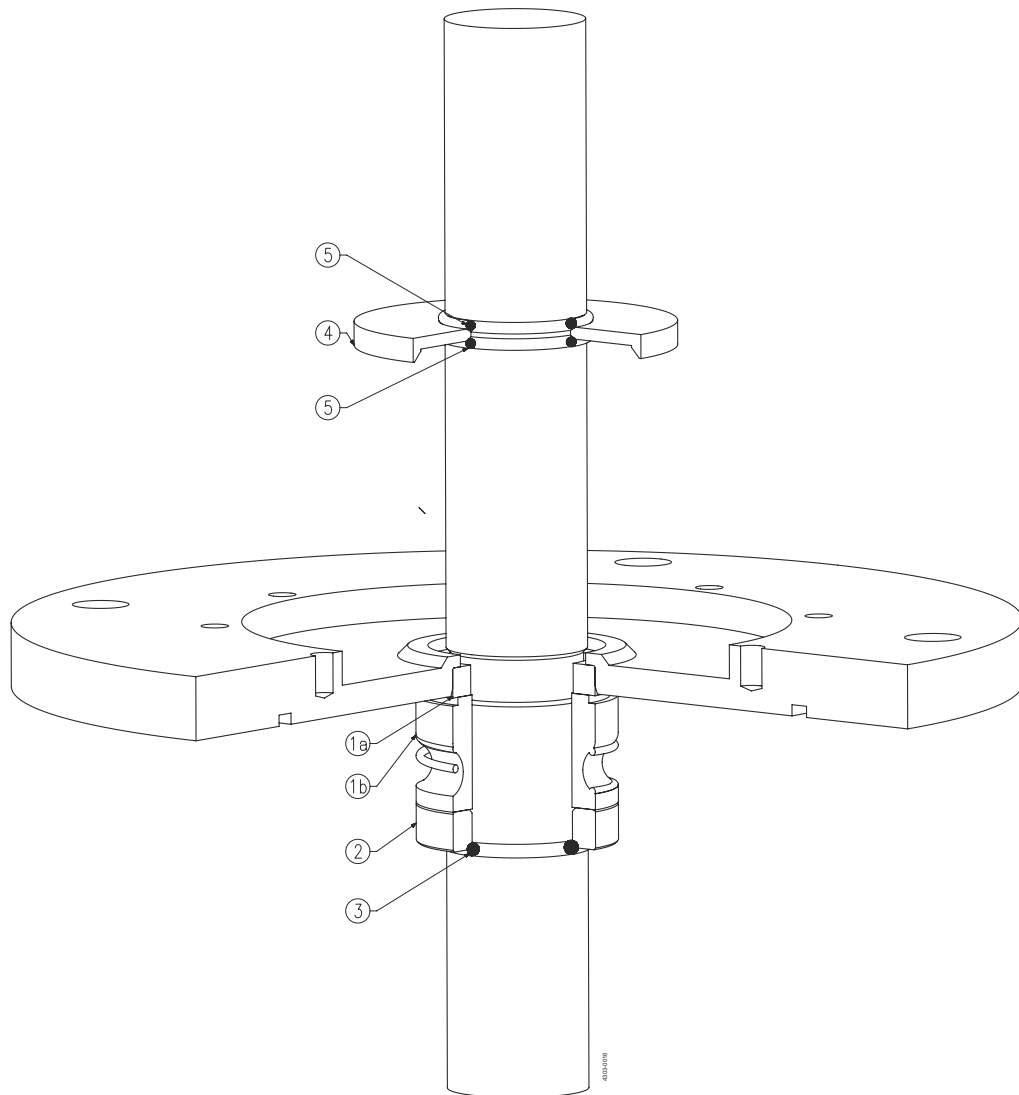

Pos.	Qty.	Denomination
1	1	S1 seal
2	1	Ring, retainer
3	2	O-ring

Pos.	Qty.	Denomination
4	1	Oil/Fluid trap
5	2	O-ring

 **NOTE**

Find item numbers in the Spare part manual available from the on-line [Alfa Laval product catalogue Anytime](#) or in the [Close at hand spare part catalogue](#).

8.8 Shaft seal, type S2

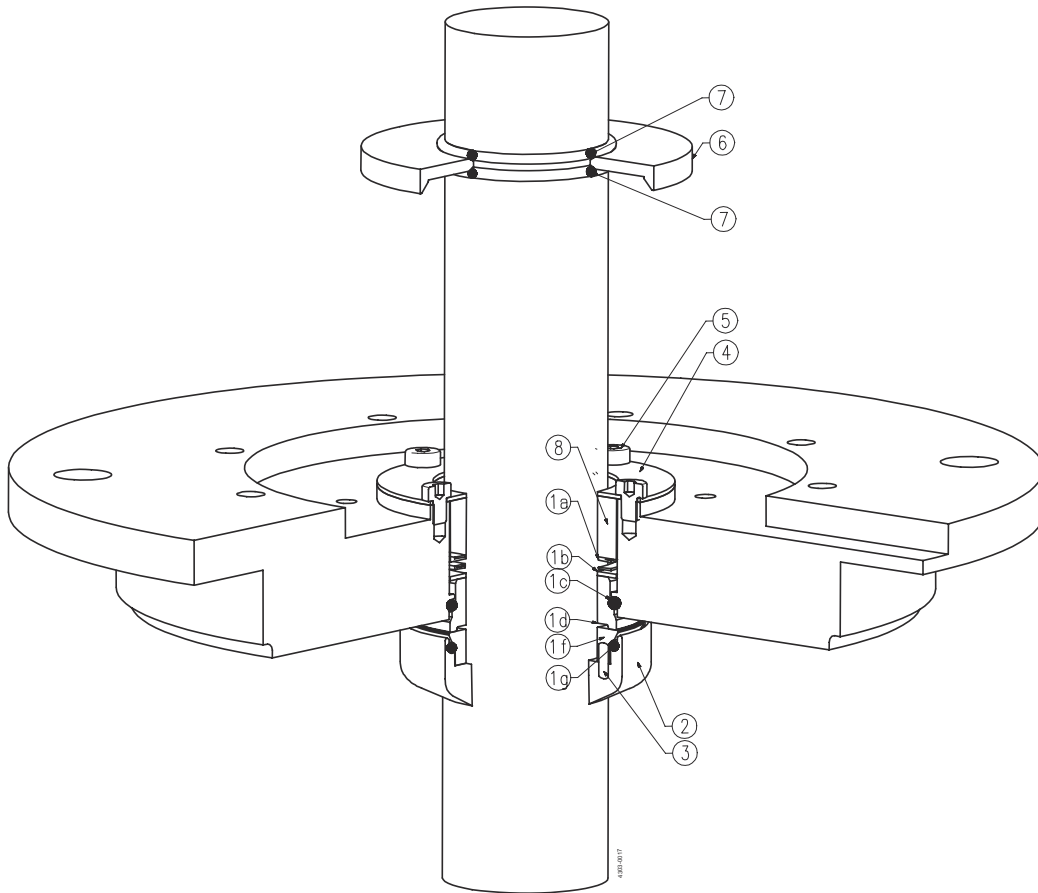

Pos.	Qty.	Denomination
1	1	S2 seal
2	1	Ring, counter ¹
3	2	Pin
4	1	Ring, retainer

Pos.	Qty.	Denomination
5	4	Screw
6	1	Oil/Fluid trap
7	2	O-ring
8	1	Spacer

¹ Welded onto shaft - maintenance must be carried out by Alfa Laval.

NOTE

Find item numbers in the Spare part manual available from the on-line [Alfa Laval product catalogue Anytime](#) or in the [Close at hand spare part catalogue](#).

8.9 Shaft seal, type S3

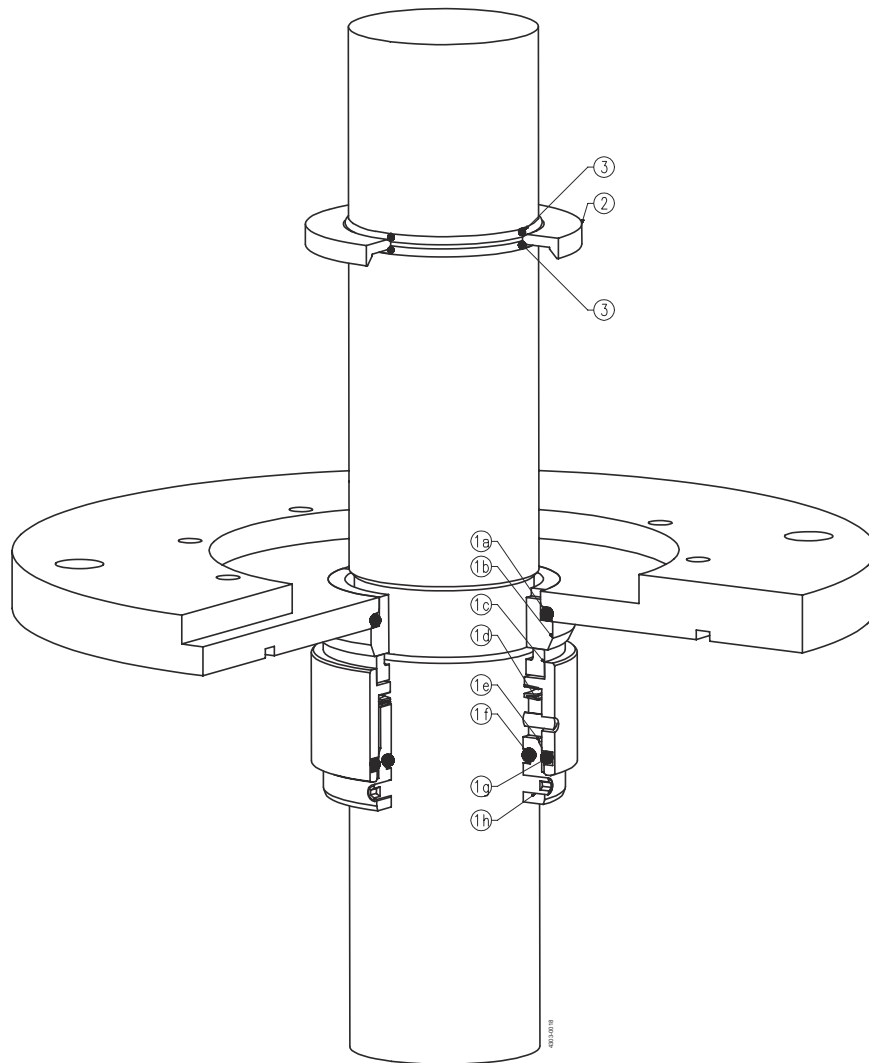

Pos.	Qty.	Denomination
1	1	S3 seal
2	1	Oil/Fluid trap
3	2	O-ring



NOTE

Find item numbers in the Spare part manual available from the on-line [Alfa Laval product catalogue Anytime](#) or in the [Close at hand spare part catalogue](#).

8.10 Tools

Retainer bolt and extractor bolt for bearing frame

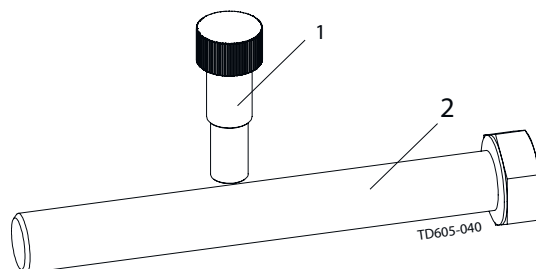
Pos	Denomination	BC160D(H)/30	B25, B25/30	B35, B35/40	B45, B45/50	B55, B55/60
		Item no.	Item no.	Item no.	Item no.	Item no.
1	Retainer bolt	TE2604036760	TE2604010700	TE2604010100	TE2604010890	TE2604010900
2	Extractor bolt	TE2601000331	TE2601000331	TE2601000336	TE2601000334	TE2601000334



9 Appendix

9.1 Drive unit instructions

The drive unit is supplied by sub supplier and all important installation requirement is transferred to the Agitator instruction manual. For further information regarding maintenance and storage of the drive unit please find the drive unit instruction manual by below links.

For agitators with gears please find the drive unit instruction manual by below link:

<https://www.nord.com/cms/en/documentation/manuals/manuals.jsp>

For agitators with direct drive (motor only) please find the motor instruction manual by below link:

<http://www.hoyer motors.com/Catalogues-30304.htm>