

Alfa Laval SBV Sanitary Ball Valve

Ball valves

Introduction

The Alfa Laval Sanitary Ball Valve (SBV) is a hygienic ball valve designed with a bore diameter the same size as the pipeline diameter. The full-bore design with zero flow restriction and minimum pressure drop makes the SBV the optimum choice to handle high-viscosity or particulate liquids. It is also ideal for use in pigging systems to prevent product waste and optimize plant performance.

Application

The Alfa Laval SBV is ideal for use across the dairy, food, beverage, brewery, chemical and many other industries.

All ball valves feature a cavity behind the ball. General considerations must be considered when selecting ball valve configuration vs. product and application.

Benefits

- Reliable full-flow performance, especially for pigging systems
- Compact, straightforward hygienic design
- Versatile operation with automated or manual control
- Durable and water hammer-safe

Standard design

The Alfa Laval sanitary ball valve consists of a valve body and two body flanges, a ball fitting into sealing seats, and a stem connecting to either a pneumatic actuator or a manual handle. The actuator is maintenance-free and prepared for position indication with inductive proximity switches. Actuated valves are delivered normally closed (NC) and can easily be rebuilt to normally open (NO).

The valve can also be fitted with the Alfa Laval sensing and control unit. Two inspection holes in the bonnet connecting the valve body and actuator enable easy inspection of the stem seal for tightness.

Standard design enables product recovery using pigging systems.

To optimise valve cleaning; a cavity cleaning option is available improving cleaning of the cavity of the valve.

The optional cavity fillers can further minimize product volumes in the cavity of the valve. Considerations are to be made on cleaning, as this option is not available in combination with cavity clean option.



Using ball valve technology; please consider valve and valve configuration (cavity filler or cavity cleaner) vs. product and cleaning parameters e.g. products with high viscosity, high sugar or high protein content vs. chemical, heat and time of cleaning. Alfa Laval recommend that products are not left to dry in the valve, as cleaning could be more demanding in e.g. time, heat and consumption of cleaning medias.

Working principle

The Alfa Laval SBV sanitary ball valve has a precision-made ball with full bore positioned inside the valve body between two flanges and two PTFE valve seats. A 90° rotation of the valve stem enables opening or closing the valve. A specially selected PTFE-grade material secures long lifetime. The use of spring-loaded, self-adjusting seal rings ensures the reliability of the valve stem sealing. Either a pneumatic actuator or a manually-operated handle with lockable positions enables valve operation. Valve screws enable assembly and disassembly for easy inspection and maintenance.

Technical Data

Temperature range	
Ambient (air):	+4 °C to +45 °C / +39 °F to +113 °F
Operating (medium dependent):	+0 °C to +95 °C / +32 °F to +203 °F
Sterilization (SIP 30 min):	EPDM +140 °C / +284 °F
	PTFE +130 °C / +266 °F
	NBR +100 °C / +212 °F
	FPM +140 °C / +284 °F
	Q +90 °C / +194 °F

Pressure	
Max. product pressure:	16 bar / 232 psi
Min. product pressure:	Full vacuum
Pressure range	
Working pressure:	16 bar / 232 psi
Cleaning pressure:	3 bar / 44 psi

ATEX	
Classification:	II 2 G D ¹

¹ This equipment is outside the scope of the directive 2014/34/EU and must not carry a separate CE marking according to the directive as the equipment has no own ignition source

Leak rate:	A (DIN EN 12266-1)
------------	--------------------

Physical Data

Materials	
Product wetted steel parts:	1.4404
Other steel parts:	1.4307
External surface finish:	Semi-bright (blasted)
Internal surface finish:	Bright (polished), Ra < 0.8 µm
Product wetted seals:	EPDM
Other seals:	NBR



If welding both flanges, ensure that the flanges can be moved axially 30-40 mm depending on size to allow for valve maintenance (see manual for further details).

Actuated valves are delivered NC (normally closed) and are easily rebuilt to NO (normally open). See manual for further details.

Options

- Male parts or clamp liners in accordance with required standard.
- Actuator for mounting of Alfa Laval Sensing and control units.
- Cavity cleaning (connections ISO 228 - G 1/2")
- Cavity filler (encapsulating valve seats).
- Handle and bracket for inductive proximity switches (manual valves).
- Product wetted elastomer seals of NBR, Q or FPM.

Dimensions (mm)

Cavity cleaning connections (optional)

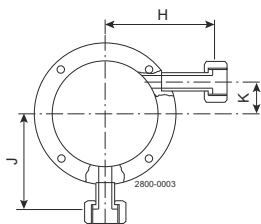

Figure 1. DN/OD 25 - 63.5 / DN 25-65

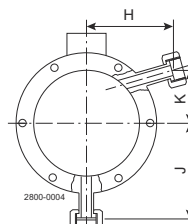

Figure 2. DN/OD 76.1 - 101.6 / DN 80-100

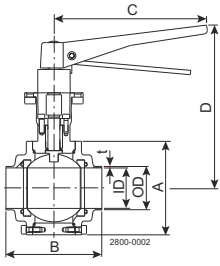

Figure 3. SBV manual

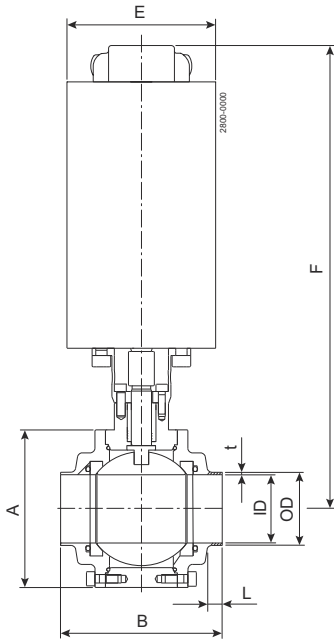

Figure 4. SBV with actuator

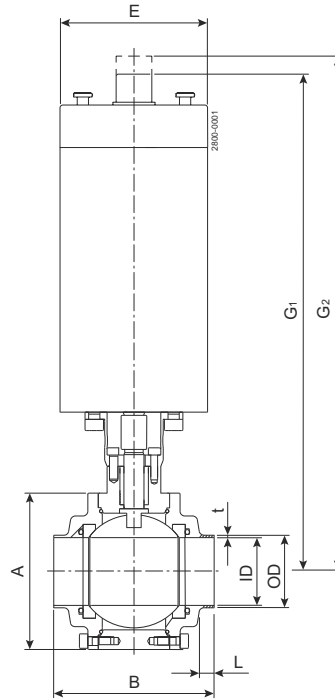

Figure 5. SBV with actuator for ThinkTop

Size	Inch tube						DIN tube					
	DN/OD		DN				DN					
	25	38	51	63.5	76.1	101.6	25	40	50	65	80	100
A	74	95	110	130	159	195	74	95	110	130	159	195
OD	25	38	51	63.5	76.1	101.6	29	41	53	70	85	104
ID	21.8	34.8	47.8	60.3	72.9	97.6	26	38	50	66	81	100
t	1.6	1.6	1.6	1.6	1.6	2	1.5	1.5	1.5	2	2	2
B	93	103	113	125	163	220	93	103	113	125	163	220
C	180	180	180	180	180	291	180	180	180	180	180	291
D	117	125	135	145	156	206	117	125	135	145	156	206
E	104	104	104	104	104	129	104	104	104	104	104	129
F	307	315	324	335	346	395	307	315	324	335	346	395
G1	334	342	350	362	372	422	334	342	350	362	372	422
G2	344	352	360	372	382	432	344	352	360	372	382	432
H	70.5	79	84	90.5	104	114	70.5	79	84	90.5	104	114
J	55	65.5	73	83	97.5	115.5	55	65.5	73	83	97.5	115.5
K	13	19	25	33	54.5	65.5	13	19	25	33	54.5	65.5
L	7.48	7.48	7.48	7.48	9.89	15.80	7.48	7.48	7.48	7.48	9.89	15.80
Weight manual (kg)	2.3	3.4	4.8	7	13.5	27	2	3.1	4.5	6.4	12.3	24
Weight actuated (kg)	6.7	7.8	9.2	11.4	17.9	35.8	6.4	7.5	8.9	10.8	17.9	32.8
Weight with												
ThinkTop® adapter (kg)	8.6	9.7	11.1	13.3	19.8	37.7	8.3	9.4	10.8	12.7	19.8	34.7

This document and its contents are subject to copyrights and other intellectual property rights owned by Alfa Laval AB (publ) or any of its affiliates (jointly "Alfa Laval"). No part of this document may be copied, re-produced or transmitted in any form or by any means, or for any purpose, without Alfa Laval's prior express written permission. Information and services provided in this document are made as a benefit and service to the user, and no representations or warranties are made about the accuracy or suitability of this information and these services for any purpose. All rights are reserved.

200002786-5-EN-GB

© Alfa Laval AB

How to contact Alfa Laval

Up-to-date Alfa Laval contact details for all countries are always available on our website at www.alfalaval.com