

LIFTING LUGS ARE DELIVERED UNASSEMBLED

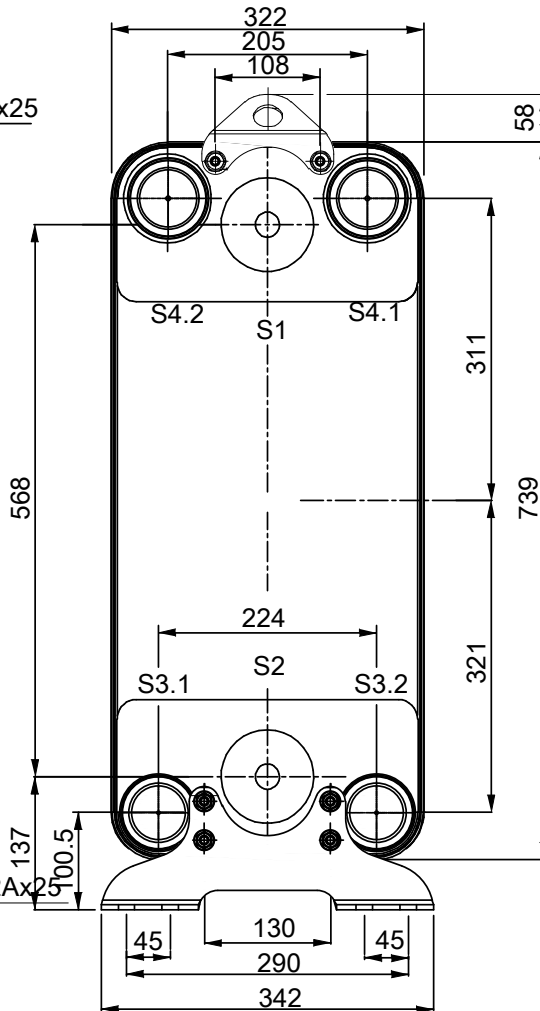

FEET ARE DELIVERED UNASSEMBLED

Diagonal flow type 6-ports:
Circuit 1 :S3.1-S4.1
Circuit 2 :S3.2-S4.2

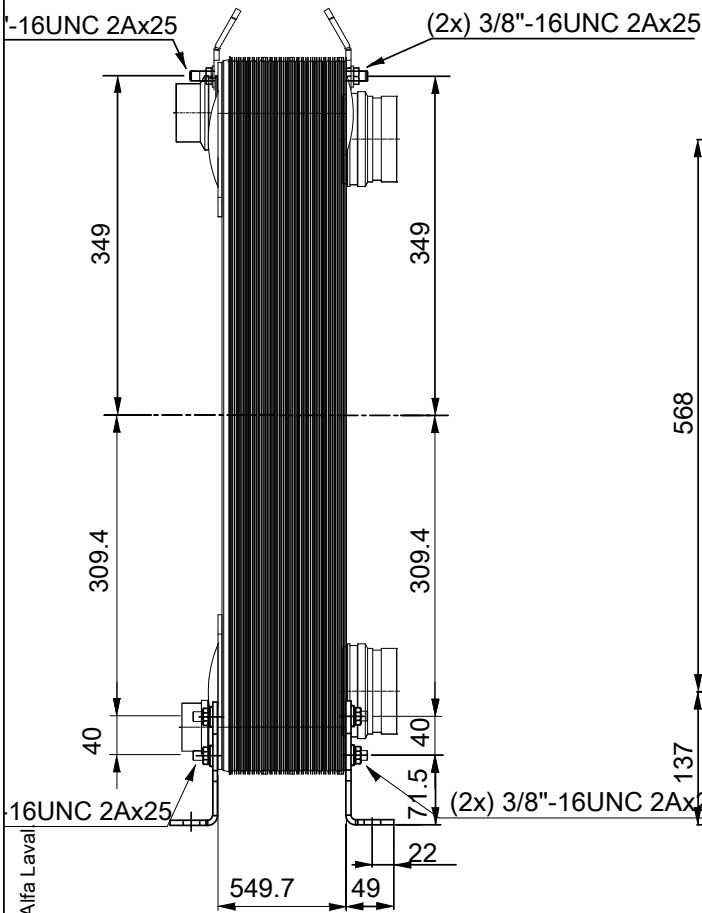
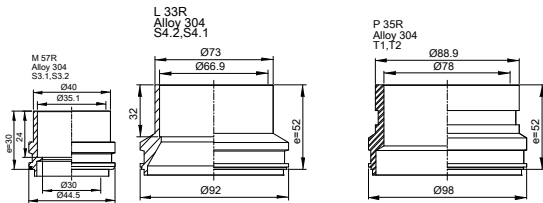
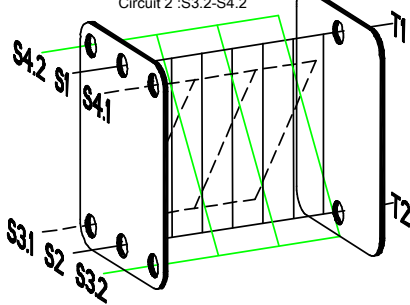

HEATING SURFACE
NETWEIGHT 188.6 kg
OPERATING WEIGHT kg
PLATE MATERIAL ALLOY 316
PLATE GROUPING 1*51HR|1*51HR|1*103HR

T1 T2 T3.1 T3.2 T4.1 T4.2 locations on back side correspond to S1 S2 S3.1 S3.2 S4.1 S4.2 on front side

ALL DIMENSIONS IN MILLIMETERS

SIDE	MEDIA	INLET	TEMP.	OUTLET	TEMP.	FLOW RATE	PRESSURE DROP	LIQUID VOL.
1		S4.2, T2		S3.2, T1				48.4 dm ³
2		S4.1		S3.1				25.5/25.5 dm ³

Note that all unique customer requirements (i.e tolerance) need to be verified thru Alfa Laval

PRESSURE VESSEL APPROVAL UL

ACH-500DQ-206H-F (3287084585)

www.alfalaval.com

CUSTOMER NAME / REF. NO.

COMPANY / REF.

TOTAL LENGTH 652.2 mm
TOTAL WIDTH 322.0 mm
TOTAL HEIGHT 838.0 mm

1/15/2024
REV 0