

Note that all unique customer requirements (i.e tolerance) need to be verified thru Alfa Laval.

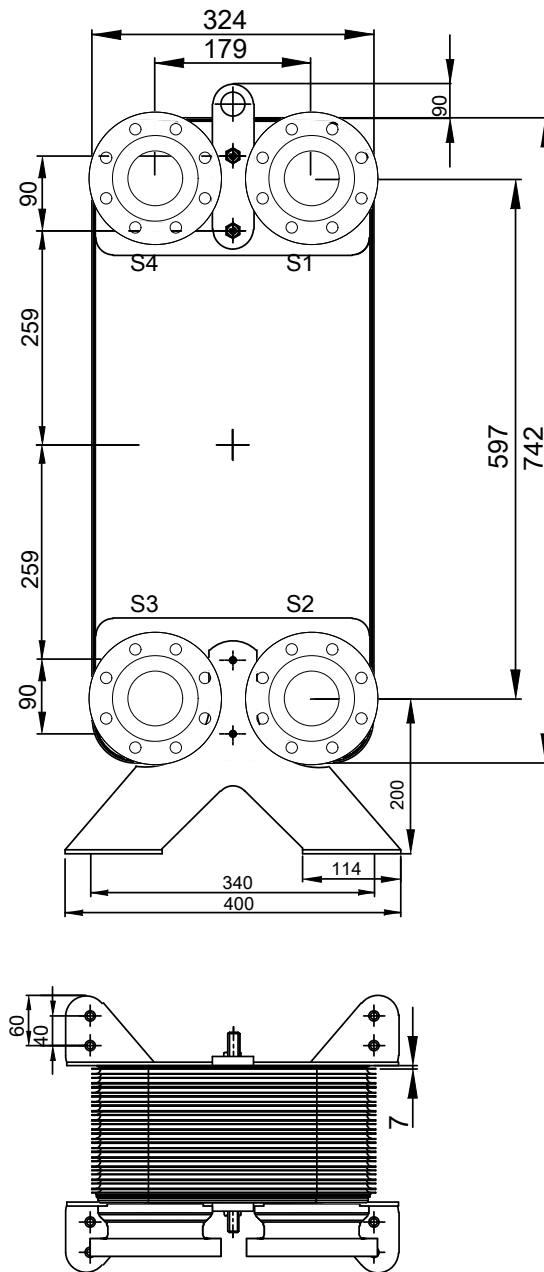
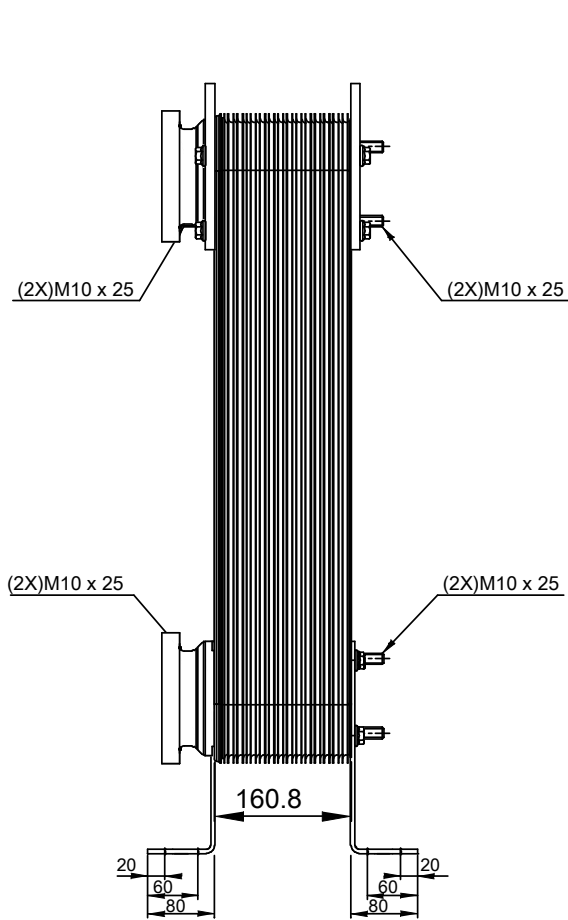
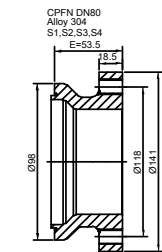

T1 T2 T3 T4 locations on back side correspond to S1 S2 S3 S4 on front side

HEATING SURFACE
 NETWEIGHT 64.2 kg
 OPERATING WEIGHT kg
 PLATE MATERIAL ALLOY 316
 PLATE GROUPING 1*34AHH/1*35AHL

ALL DIMENSIONS IN MILLIMETERS

SIDE	MEDIA	INLET	TEMP.	OUTLET	TEMP.	FLOW RATE	PRESSURE DROP	LIQUID VOL.
1		S1		S2				22.3 dm ³
2		S3		S4				14.1 dm ³

PRESSURE VESSEL APPROVAL

PED/UK



CB210-70AH-F (3075035778)

www.alfalaval.com

CUSTOMER NAME / REF. NO.

TOTAL LENGTH 320.8 mm
 TOTAL WIDTH 324.0 mm
 TOTAL HEIGHT 959.0 mm

COMPANY / REF.



4/16/2024
 REV 0