

Gasketed plate heat exchangers

All products

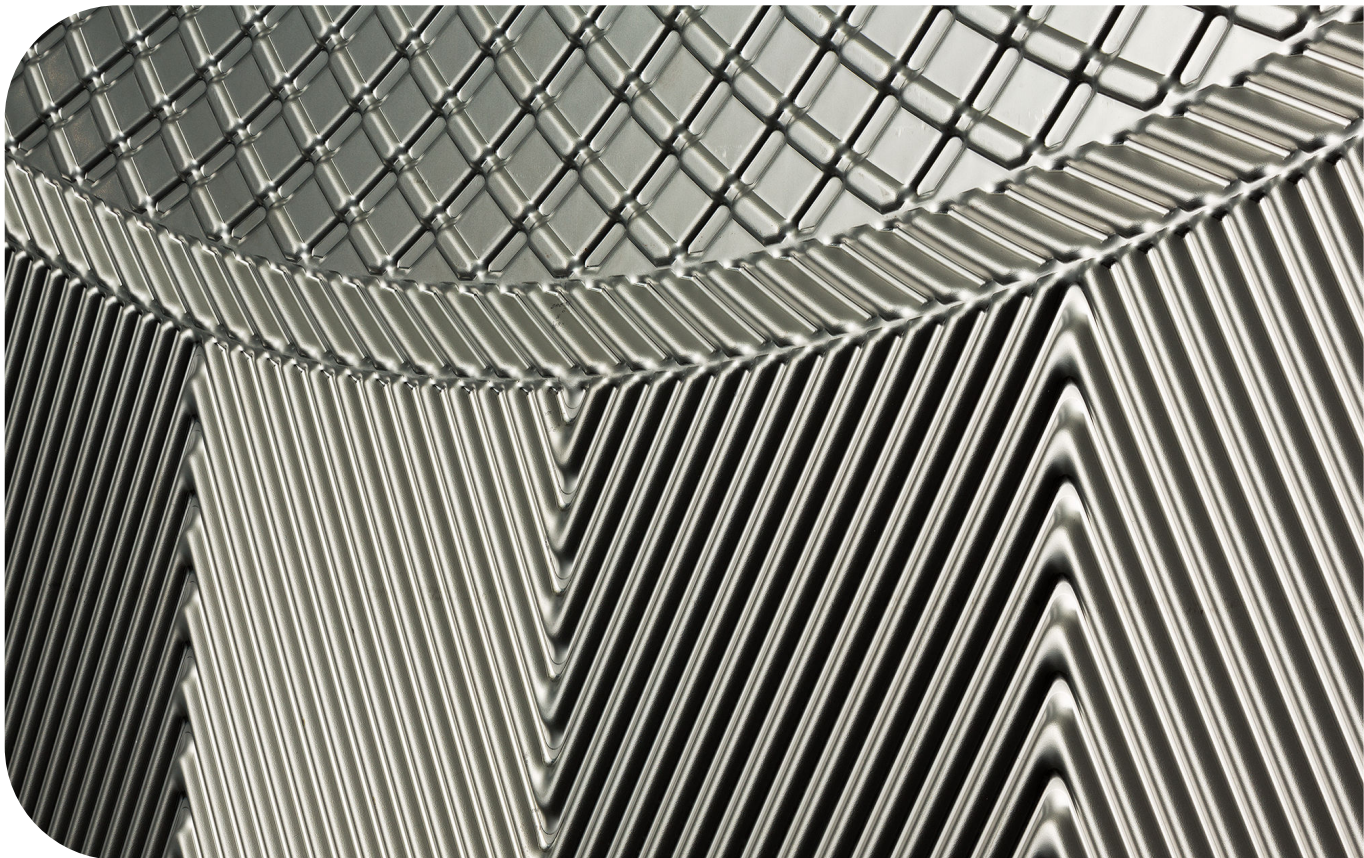

Lit. Code

200006684-4-EN-GB

Maintenance Manual

Published by

Alfa Laval Technologies AB

Box 74

SE-221 00 Lund, Sweden

Telephone switchboard: +46 46 36 65 00

info@alfalaval.com

The original instructions are in English

© Alfa Laval AB 2024-04

This document and its contents are subject to copyrights and other intellectual property rights owned by Alfa Laval AB (publ) or any of its affiliates (jointly "Alfa Laval"). No part of this document may be copied, re-produced or transmitted in any form or by any means, or for any purpose, without Alfa Laval's prior express written permission. Information and services provided in this document are made as a benefit and service to the user, and no representations or warranties are made about the accuracy or suitability of this information and these services for any purpose. All rights are reserved.



English

Use the QR code, or visit www.alfalaval.com/gphe-manuals, to download a local language version of the manual.

العربية

استخدم رمز الاستجابة السريعة أو قم بزيارة www.alfalaval.com/gphe-manuals لتنزيل إصدار اللغة المحلية للدليل ،

български

Използвайте QR кода или посетете следния адрес www.alfalaval.com/gphe-manuals, за да свалите версия на ръководството за употреба на Вашия език.

Český

Použijte kód QR nebo navštivte www.alfalaval.com/gphe-manuals a stáhněte si místní jazykovou verzi tohoto návodu.

Dansk

Brug QR-koden, eller følg www.alfalaval.com/gphe-manuals for at downloade en lokal sprogversion af manualen.

Deutsch

Verwenden Sie den QR-Code oder besuchen Sie www.alfalaval.com/gphe-manuals, um die lokale Sprachversion des Handbuchs herunterzuladen.

ελληνικά

Χρησιμοποιήστε τον κωδικό QR ή επισκεφτείτε τη σελίδα www.alfalaval.com/gphe-manuals, για να κατεβάσετε μια έκδοση του εγχειριδίου στην τοπική σας γλώσσα.

Español

Utilice el código QR o visite www.alfalaval.com/gphe-manuals para descargar una versión del manual en el idioma local.

Eesti

Kasutusjuhendi kohaliku keeleversiooni allalaadimiseks kasutage QR-koodi või külastage aadressi www.alfalaval.com/gphe-manuals.

Suomi

Käytä QR-koodia tai avaa osoite www.alfalaval.com/gphe-manuals, niin voit ladata käyttöohjeen paikallisella kielellä.

Français

Utilisez le QR-code ou rendez-vous sur le site www.alfalaval.com/gphe-manuals, pour télécharger une version du manuel dans la langue locale.

Hrvatski

Upotrijebite QR kod ili posjetite www.alfalaval.com/gphe-manuals ako želite preuzeti verziju priručnika na lokalnom jeziku.

Magyar

Használja a QR-kódot, vagy látogasson el a www.alfalaval.com/gphe-manuals webhelyre a kézikönyv helyi nyelvű változatának letöltéséhez.

Italiano

Utilizzate il codice QR o visitate il sito www.alfalaval.com/gphe-manuals per scaricare una versione del manuale nella lingua locale.

日本語

コード、または www.alfalaval.com/gphe-manuals、現地語版のマニュアルをダウンロードすることができます。

한국어

코드를 사용하거나 www.alfalaval.com/gphe-manuals 에서 사용 설명서의 해당 언어 버전을 다운로드 하십시오.

Lietuvos

Naudokite greitojo atsako (QR) kodą arba apsilankykite www.alfalaval.com/gphe-manuals , kad atsisiųstumėte vadovo vietos kalbos versiją.

Latvijas

Lai lejupielādētu rokasgrāmatas versiju vietējā valodā, izmantojiet QR kodu vai apmeklējiet www.alfalaval.com/gphe-manuals.

Nederlands

Gebruik de QR-code, of bezoek www.alfalaval.com/gphe-manuals om een handleiding in een andere taal te downloaden.

Norsk

Bruk QR-koden, eller gå til www.alfalaval.com/gphe-manuals for å laste ned en versjon av håndboken på et lokalt språk.

Polski

Aby pobrać instrukcję w innej wersji językowej, zeskanuj kod QR lub otwórz stronę www.alfalaval.com/gphe-manuals.

Português

Utilize o código QR ou visite www.alfalaval.com/gphe-manuals para descarregar uma versão do manual na língua local.

Português do Brasil

Use o QR ou visite www.alfalaval.com/gphe-manuals para baixar uma versão do manual no idioma local.

Românesc

Utilizați codul QR sau vizitați www.alfalaval.com/gphe-manuals, pentru a putea descărca o versiune a manualului în limba dumneavoastră.

Русский

Чтобы загрузить руководство на другом языке, воспользуйтесь QR-кодом или перейдите по ссылке www.alfalaval.com/gphe-manuals.

Slovenski

Če želite prenesti lokalno jezikovno različico priročnika, uporabite kodo QR ali obiščite spletno stran www.alfalaval.com/gphe-manuals.

Slovenský

Použite QR kód alebo navštívte stránku www.alfalaval.com/gphe-manuals a stiahnite si verziu príručky v miestnom jazyku.

Svenska

Använd QR-koden eller besök www.alfalaval.com/gphe-manuals för att hämta en lokal språkversion av bruksanvisningen.

Türkçe

Kılavuzun yerel dildeki versiyonunu indirmek için QR kodunu kullanın veya www.alfalaval.com/gphe-manuals adresini ziyaret edin.

中国

请使用二维码或访问 www.alfalaval.com/gphe-manuals，以下载本地语言版本的手册。

Contents

1	Introduction	7
1.1	Intended use	7
1.2	Reasonably foreseeable misuses	7
1.3	Prior knowledge to handle the equipment	7
1.4	Available technical information	8
1.5	Warranty conditions	8
1.6	Advice	8
1.7	Environmental compliance	9
2	Safety	11
2.1	Safety considerations	11
2.2	Definitions of expressions	11
2.3	Personal protective equipment	12
2.4	Working at height	13
3	Description	15
3.1	Components	15
3.1.1	Industrial gasketed plate heat exchangers	16
3.1.2	Hygienic gasketed plate heat exchangers	20
3.2	Type plate	23
3.3	A-measurement	25
3.4	Plate identification	26
3.5	Plate hanging list	30
3.5.1	Quick guide for plate hanging	30
3.5.2	How to interpret the denomination	31
3.5.3	How to interpret the illustration	33
3.6	External inspection of a plate package	34
3.7	Bolt configuration	35
3.8	Function	36
3.8.1	Configuration with single pass	37
3.8.2	Configuration with semi-welded cassettes	38
3.8.3	Configuration with multi-pass	39
3.8.4	Configuration with multi-section	40
4	Maintenance	41
4.1	Plate heat exchanger	41
4.1.1	Plate heat exchanger — Drain	41
4.1.2	Plate heat exchanger — Open	42
4.1.3	Tightening torque	46
4.1.4	Plate heat exchanger — Close	47
4.1.4.1	Hard gasket materials	49

4.1.5	Removal, lifting and insertion of plates in the field.....	51
4.1.6	Leakage test.....	52
4.1.7	Cleaning.....	53
	4.1.7.1 Cleaning agents.....	54
	4.1.7.2 Cleaning-In-Place (CIP).....	56
	4.1.7.3 Manual (mechanical) cleaning.....	59
4.1.8	Removable lifting equipment.....	60
	4.1.8.1 Removable lifting device.....	60
4.2	Frame.....	63
4.2.1	Assembly of feet.....	63
4.3	Plate.....	65
4.3.1	Replacement of a limited number of plates.....	65
4.3.2	Regasketing of a plate.....	66
	4.3.2.1 Use of double sided acrylic tape.....	67
	4.3.2.2 Plate — Change ClipGrip™ and Clip-on gaskets.....	72
	4.3.2.3 Plate — Change Clip-ad and Base-ad gaskets.....	74
	4.3.2.4 Plate — Change glued gaskets.....	76
5	Storage.....	79
5.1	Taken out of service.....	80

1 Introduction

This manual provides information needed for maintenance of a gasketed plate heat exchanger.

1.1 Intended use

The intended use of this equipment is to transfer heat in accordance with a decided configuration for a given thermal duty.

Alfa Laval will not be held responsible for injury or damage if the equipment is used for any other purpose than the intended use described above. All other use is prohibited.

1.2 Reasonably foreseeable misuses

- Do not lift or transport the crate nor the equipment in any other way than stated in the *Installation Manual*.
- Connect a pipe in the way it is meant to be connected to the plate heat exchanger. Gasket and lining can be damaged if a pipe is connected in the wrong way.
- For semi-welded models and other models with asymmetric configuration it is a safety issue if the wrong pipe is connected to the wrong port. Ensure that the correct media is connected to the correct port according to the plate heat exchanger drawing.
- There is a risk to damage the hangers if many plates are hung or moved at a time. It is recommended to handle one, or maximum two, plates at a time.
- When tightening to the A-measurement (the distance between the inside of the frame plate and the inside of the pressure plate), always tighten the bolts crosswise, evenly, and a little at a time to avoid diagonal shifting and snaking. The number of plates and the A-measurement can be found on the plate heat exchanger drawing.
- Increase and decrease flow gently to avoid plate deformations and gasket blow-outs by for example water hammer.
- At start-up, raise the temperature gently to avoid cracks in the gaskets or create a blow-out. See Section *Start-up* in the *Installation Manual*.
- If the plate heat exchanger will not be in operation for a long period of time, follow the instructions in Section [Storage](#).

1.3 Prior knowledge to handle the equipment

The plate heat exchanger shall be operated by personnel who have studied the instructions in this manual and have knowledge of the process where the heat exchanger is installed. This includes knowledge of precautions regarding media type, pressures, temperatures in the plate heat exchanger as well as process specific precautions.

Maintenance and installation of the plate heat exchanger shall be done by persons who have knowledge and authorization according to local regulations. This may include work with piping, welding and other kinds of maintenance.

For maintenance actions not described in this manual, contact Alfa Laval for advice.

1.4 Available technical information

In addition to this manual, please keep the following documentation at hand:

- **Declaration of Conformity**
If applicable.
- **Parts list**
A list of components included in the configuration of the product.
- **Plate hanging list**
A description of the included plates and gaskets and the sequence that they are installed in the plate heat exchanger.
- **Plate heat exchanger drawing**
A drawing of the delivered plate heat exchanger.

The listed documents are unique for the delivered product.

1.5 Warranty conditions

The warranty conditions are usually included in the signed sales contract prior to the order of the delivered plate heat exchanger. Alternatively, the warranty conditions are included in the sales offer documentation or with a reference to the document specifying the valid conditions. If faults occur during the specified warranty period, always consult Alfa Laval for advice.

1.6 Advice

Always consult Alfa Laval for advice if:

- The number of plates are intended to be changed.
- Operating temperatures and pressures are to be changed, or if other fluids are to be processed in the plate heat exchanger.

1.7 Environmental compliance

If operating Alfa Laval's heat exchangers in an optimal way and following the maintenance recommendations, this will maximize the energy savings and minimize the operational expenses (OPEX).

Waste management

Separate, recycle, or dispose all material and components in a safe, and environmentally responsible way according to national legislation or local regulations. If there is any uncertainty regarding what material a component is made of, contact the local Alfa Laval sales company.

Unpacking

Packing material consists of wood, plastics, cardboard boxes and, in some cases, metal straps.

- Wood and cardboard boxes can be reused, recycled or used for energy recovery.
- Plastics should be recycled or burnt at a licensed waste incineration plant.
- Metal straps should be sent for material recycling.

This page is intentionally left blank.

2 Safety

2.1 Safety considerations

The plate heat exchanger shall be used and maintained in accordance with Alfa Laval's instructions in this manual. Incorrect handling of the plate heat exchanger may result in serious consequences with injuries to persons and/or property damage. Alfa Laval will not accept responsibility for any damage or injury resulting from not following the instructions in this manual.

The plate heat exchanger should be used in accordance with the specified configuration of material, media types, temperatures and pressure for the specific plate heat exchanger.

2.2 Definitions of expressions



WARNING Type of hazard

WARNING indicates a potentially hazardous situation which, if not avoided, could result in death or serious injury.



CAUTION Type of hazard

CAUTION indicates a potentially hazardous situation which, if not avoided, may result in minor or moderate injury.



NOTE

NOTE indicates a potentially hazardous situation which, if not avoided, may result in property damage.



2.3 Personal protective equipment

Protective shoes

Shoes with reinforced toe cap. Minimize foot injuries caused by dropped articles.



Protective helmet

Helmet designed to protect the head from accidental injury.



Protective goggles

Tight-fitting eyeglasses worn to protect the eyes from hazards.



Protective gloves

Gloves that protect the hands from hazards.



Safety

2.4 Working at height

**WARNING****Risk of falling.**

For any kind of work at height, always ensure that safe means of access is available and used. Follow local regulations and guidelines for work at height. Use scaffolds or a mobile work platform and a safety harness. Create a safety perimeter around the working area and secure tools or other objects from falling.

If the installation requires working at a height of two meters or higher, safety arrangements must be taken in consideration.



Safety



Safety

This page is intentionally left blank.

3 Description

3.1 Components

This chapter describes the main components and accessories of Alfa Laval gasketed plate heat exchangers.

3.1.1 Industrial gasketed plate heat exchangers

Main components

The illustration shows an exploded Alfa Laval T15 with alternative components.

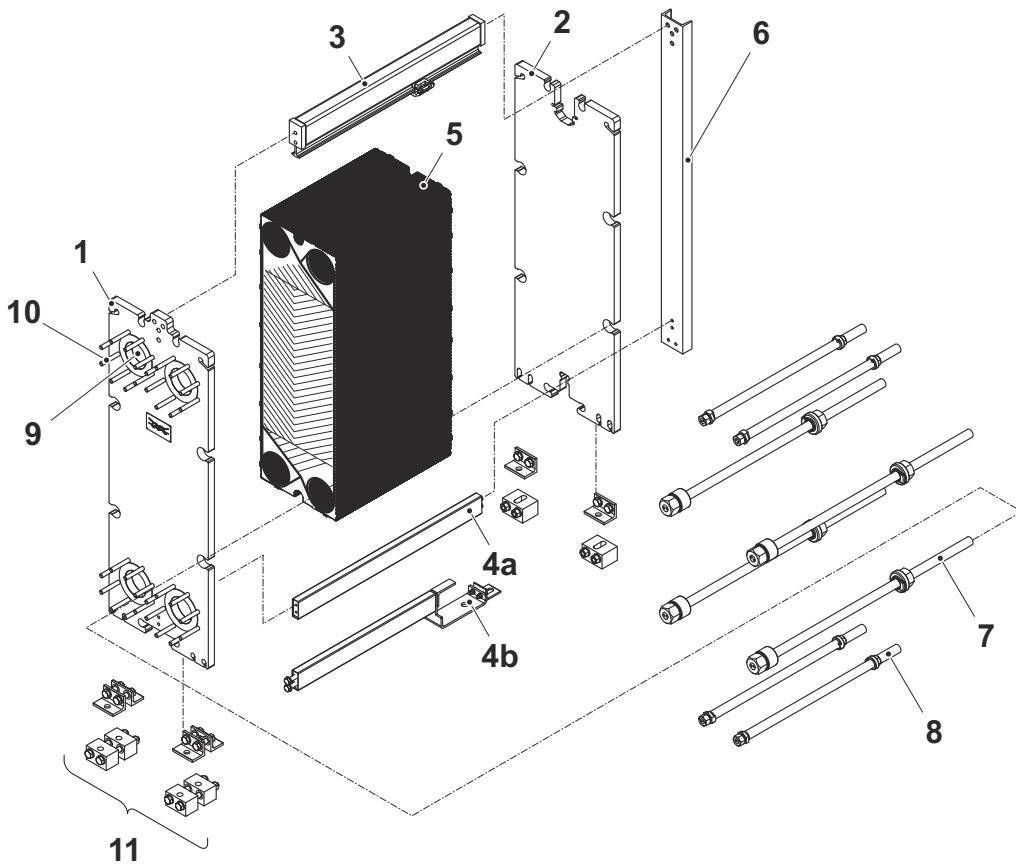
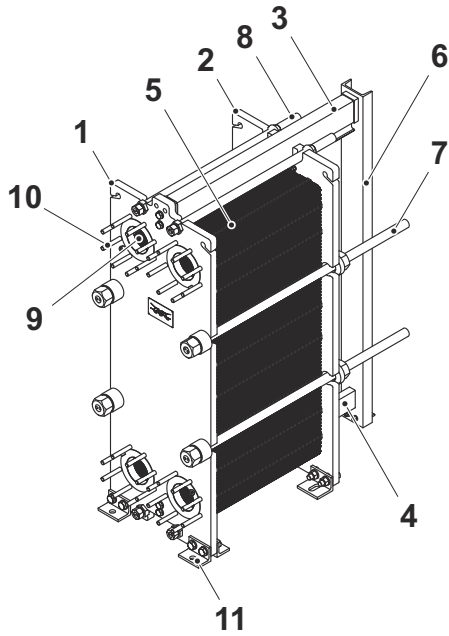

1. Frame plate

Fixed plate with various numbers of portholes for connection to the piping system.

2. Pressure plate

Moveable plate that compresses the plate package against the frame plate. The pressure plate can contain various numbers of portholes for connection to the piping system.

3. Carrying bar

Carries the plate package and the pressure plate.

4. Guiding bar

Keeps all the plates aligned at their lower end.

a. Standard

b. Compact design

5. Plate package

A plate package consists of two end plates and several plates that transfer heat. Depending on configuration there are also other types of plates in use. All plates except the partition plate are equipped with gaskets to seal off between the channels for the fluids and to the surroundings. The following plate types exist:

- End plate I

The plate placed next to the pressure plate. (For semi-welded products this plate is called End plate II.)

- End plate II

The plate placed next to the frame plate. (For semi-welded products this plate is called End plate I.)

- Channel plate

Plate that transfers heat.

- Cassette

For semi-welded products, two plates are welded together forming a cassette.

- Transition plate

For configurations with a holed pressure plate. Used as sealing towards the pressure plate. Only has contact with the media in the ports.

- Turning plate

Plate that re-directs the fluids in a multi-pass configuration.

- Partition plate

For bigger sized models with high flowrate and when they are configured with multi-pass, sometimes partition plates are used. The partition plate supports the unholed ports of a turning plate.

6. Support column

Supports the carrying bar and the guiding bar. For some smaller plate heat exchanger models no support column is used.

7. Tightening bolt

Compresses the plate package between the frame plate and the pressure plate.

8. Locking bolt

Shorter than a tightening bolt and used to lock the plate package even more.

9. Porthole

Porthole through the frame plate allows the media to enter into or exit from the plate heat exchanger.

10. Stud bolts

Threaded stud bolts around the portholes for assembling of flange connections to the plate heat exchanger. Also other connection types exist, see below.

11. Feet

Give stability to the plate heat exchanger and can, depending on the design, be used to secure the plate heat exchanger with bolts to the foundation.

Connections

- **Flange connection**

Stud bolts prepared for assembling of flange connections.

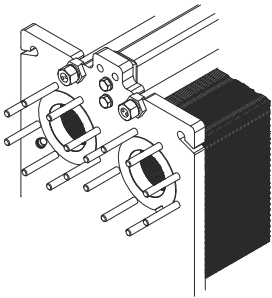

- **Pipe connection**

The plate heat exchanger can be equipped with fixed pipe connection for different types of attachments such as pipes for welding, threaded pipes or grooved pipes.

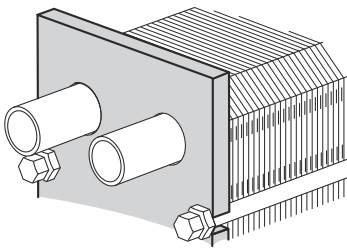

- **Rectangular loose flange**

The rectangular loose flange is a special flange supplied by Alfa Laval to be used with the customers piping and is attached with four stud bolts.

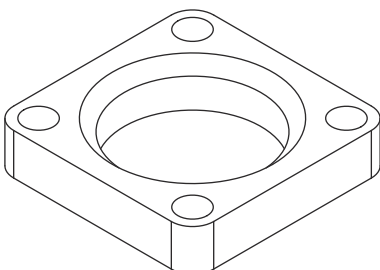

Optional equipment

- **Inspection cover**
Used to allow inspection through an unused porthole. Can be equipped with a drainage pipe.
- **Protection sheet**
Covers the plate package and protects the surroundings in case of sudden leakage of hot or hazardous fluid.
- **Bolt protection**
Plastic or stainless steel tube that protects the threads of a tightening bolt.
- **Insulation**
To protect people from touching surfaces that are dangerously hot or cold, insulation can be used.
- **Lifting device**
Separate device that is attached to the plate heat exchanger and used when lifting the plate heat exchanger.
- **Earthing lug**
Earthing connection used to eliminate the risk of static electricity.
- **Nozzle covers**
Cover the port holes and prevent foreign objects from entering the heat exchanger during storage and transport.
- **Port filter**
Prevents particles from entering the plate heat exchanger during operation.
- **Drip tray**
Collects any droplets and prevents possible leakage from dripping on the floor.

3.1.2 Hygienic gasketed plate heat exchangers

Main components

The illustration shows an exploded Alfa Laval H8 with alternative components.

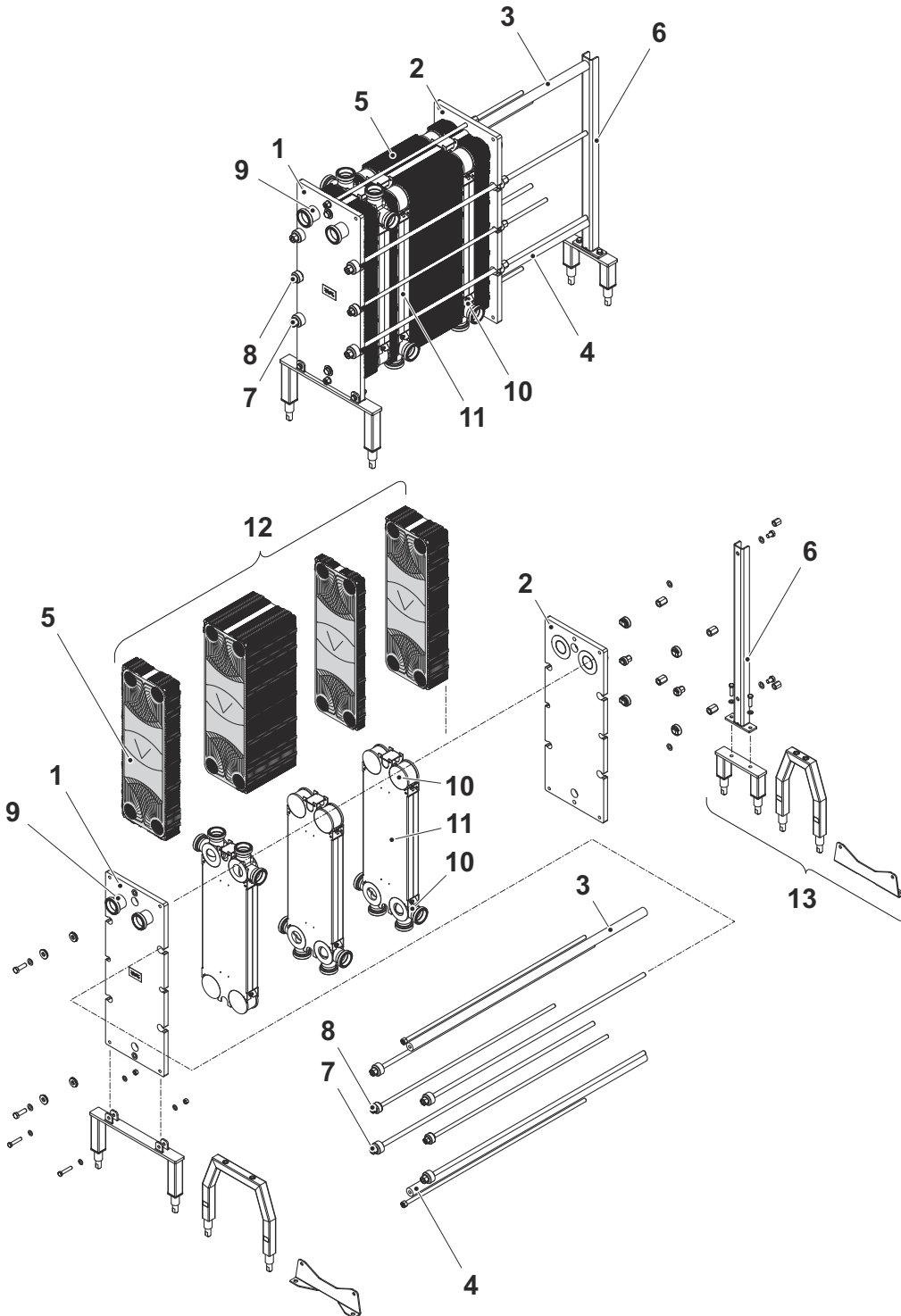

1. Frame plate

Fixed plate with various numbers of portholes for connection to the piping system.

2. Pressure plate

Moveable plate that compresses the plate package against the frame plate. The pressure plate can contain various numbers of portholes for connection to the piping system.

3. Carrying bar

Carries the plate package and the pressure plate.

4. Guiding bar

Keeps all the plates aligned at their lower end.

5. Plate package

A plate package consists of two end plates and several plates that transfer heat. Depending on configuration there are also other types of plates in use. All plates are equipped with gaskets to seal off between the channels for the fluids and to the surroundings. The following plate types exist:

- End plate I

The plate placed next to the pressure plate.

- End plate II

The plate placed next to the frame plate.

- Channel plate

Plates that transfer heat.

- Transition plate

For configurations with a holed pressure plate. Used as sealing towards the pressure plate. Only has contact with the media in the ports.

- Turning plate

Plate that re-directs the fluids in a multi-pass configuration.

6. Support column

Supports the carrying bar and the guiding bar.

7. Tightening bolt

Compresses the plate package between the frame plate and the pressure plate.

8. Locking bolt

Shorter than a tightening bolt and used to lock the plate package even more.

9. Connection

Pipes with hygienic fittings or flanges allow the media to enter into or exit from the plate heat exchanger.

10. Corner

Component on a connection plate that can have different functions depending on the design. Allow the media to enter into or exit from a plate heat exchanger section.

11. Connection plate

A connection plate divides the plate package into sections allowing two or more heat transfer processes in one plate heat exchanger.

12. Section

A section is a part of the complete plate package.

13. Feet

Gives stability to the plate heat exchanger and can, depending on the design, be used to secure the plate heat exchanger with bolts to the foundation.

Optional components**• Protection sheet**

Covers the plate package and protects the surroundings in case of sudden leakage of hot or hazardous fluid.

• Bolt protection

Plastic or stainless steel tubes that protect the threads of the tightening bolts.

• Nozzle covers

Cover the port holes and prevent foreign objects from entering the heat exchanger during storage and transport.

3.2 Type plate

The type plate is in most cases assembled on the frame plate. It may also be assembled on the pressure plate. The type plate can be a plate of steel or a sticker label.

 **WARNING** Risk of damage to equipment.

The design pressure and the design temperature are both marked on the type plate. These must not be exceeded.

 **CAUTION** Risk of damage to equipment.

Avoid aggressive chemicals for cleaning the plate heat exchanger when a sticker label is used.

The design pressure (11) and the design temperature (10), as given on the type plate, are the values against which the plate heat exchanger is approved according to the pressure vessel code in question. The design temperature (10) may exceed the recommended operating temperature (8) for the gaskets. If the operating temperatures as specified on the plate heat exchanger drawing are to be changed the supplier should be consulted.

1. Space for logotype
2. Website for service
3. Website for service (for industrial products)
or
Drawing of possible locations of connections (for hygienic products)
4. Space for mark of approval
5. Warning, read manual
6. Date of pressure test
7. Maximum operating temperature
8. Manufacturer test pressure (PT)
9. Allowable temperatures Min./Max. (TS)
10. Allowable pressures Min./Max. (PS)
11. Volume of each channel (V)
12. Locations of the connections for each fluid
13. Fluid classification group
14. Year of manufacture
15. Serial number
16. Product model
17. Manufacturer's name

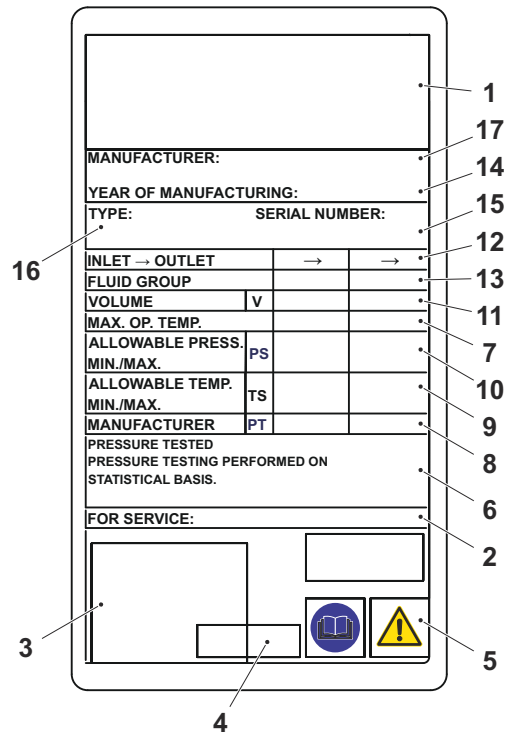
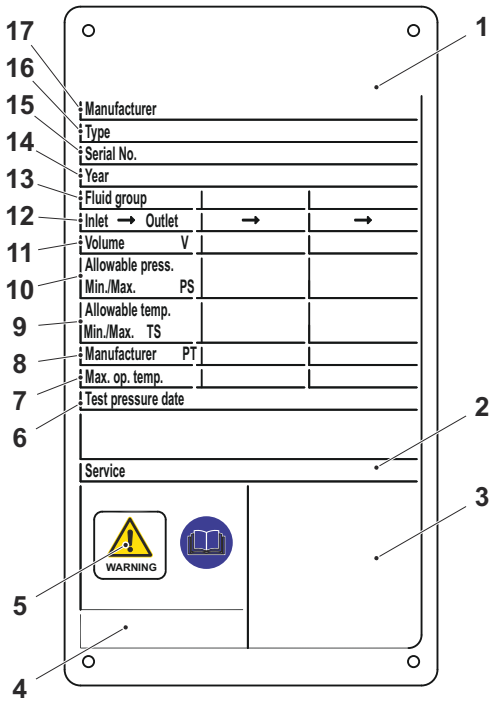

Example of type plates.

3.3 A-measurement

The A-measurement is the distance from the inside of the frame plate (1) to the inside of the pressure plate (2).

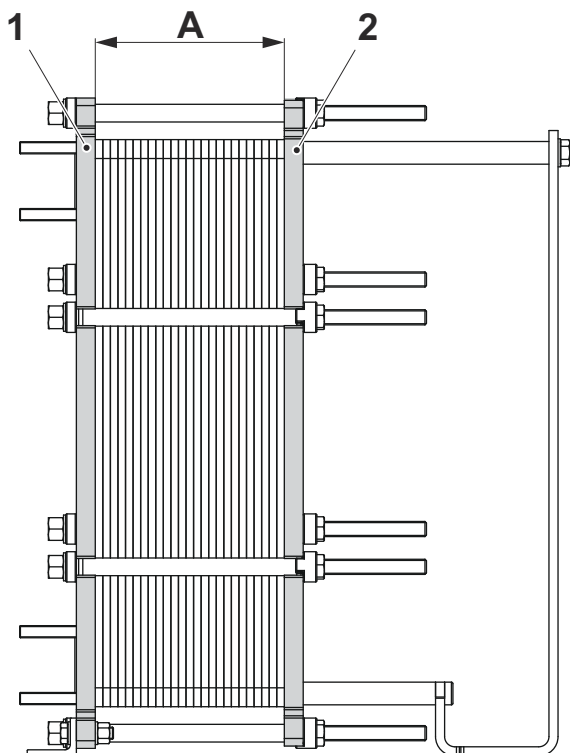

Gasketed plate heat exchanger with one plate package.

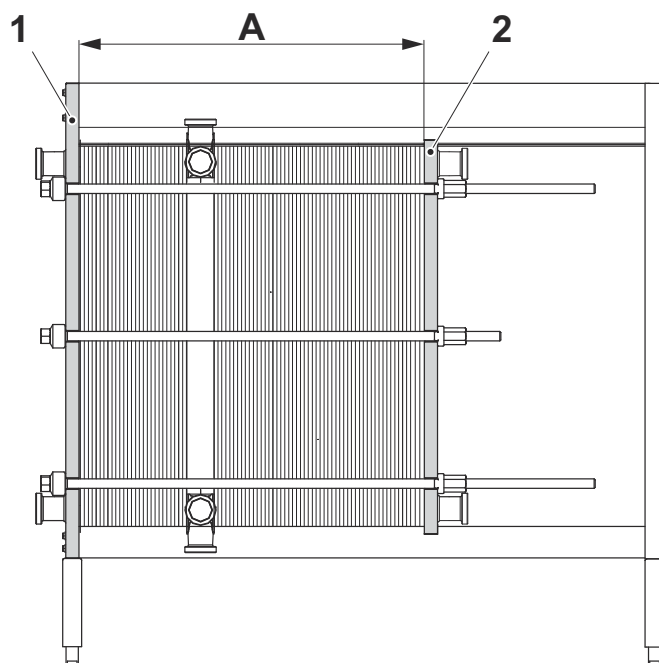

Gasketed plate heat exchanger with several plate package sections.

3.4 Plate identification

The plates are marked with the information listed in the table below. Marking is found on both sides of the plate and in both short ends of the plate. In some cases, marking can be found on the long side of the plate.

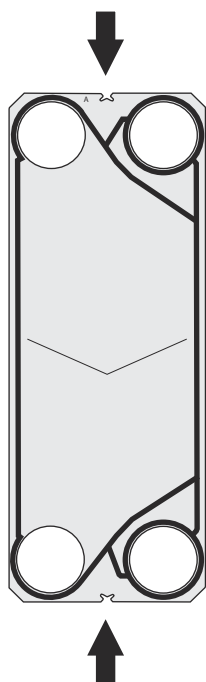

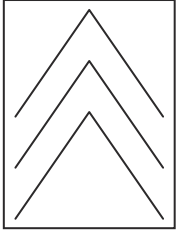
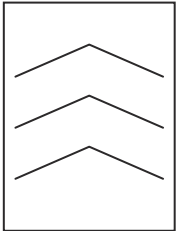
Marking	Example	Comment
Name of plate, plate variant and chevron angle type	DR6P-1	<p>DR6 is the name of the plate used for the product model T6.</p> <p>P is the name of the plate variant.</p> <p>1 is the chevron angle type.</p> <p>Chevron angle type 1 1 = low chevron angle</p>  <p>2 = high chevron angle</p> 
Manufacturing country	S	<p>S = Sweden</p> <p>Ch = China</p> <p>I = India</p>
Plate material	DA12	<p>DA = Alfa Laval internal reference (example)</p> <p>12 = code for plate material</p> <p>Most commonly used material codes:</p> <p>12 Alloy 304</p> <p>27 Alloy 316/316L</p> <p>34 Alloy 254</p> <p>40 Ti</p> <p>45 TiPd</p> <p>60 Ni</p> <p>64 Alloy C276</p> <p>73 Alloy G30</p> <p>74 Alloy D205</p> <p>75 Alloy C2000</p> <p>For other codes, please contact Alfa Laval.</p>

Marking	Example	Comment
Thickness	05	Plate thickness: 04 = 0.4 mm 05 = 0.5 mm 06 = 0.6 mm etc.
Charge number	870117	Identification of the batch. Number of digits can be higher or lower.
Short end of plate	A	Marking is A or B. A is always marked, but sometimes B is not marked. The <i>Plate hanging list</i> tells which end of the plate that is pointing upwards.
Side of plate	W	Applicable only for asymmetric plates, see section below. W or R = wide side N or V = narrow side

Symmetric and asymmetric plates

The plate pattern can be either symmetric or asymmetric. This is principally illustrated in the image below.



Symmetric plate



Asymmetric plate

Imagine that the two sides of each plate are filled with water. For the symmetric plate, both sides will hold equally much water. For the asymmetric plate, the wide side (upper side in the image) will hold more water than the narrow side (lower side in the image). When the thermal duty is asymmetric, asymmetric plates enable higher possibilities to optimize the configuration of the heat exchanger.

Symmetric channels with symmetric plates

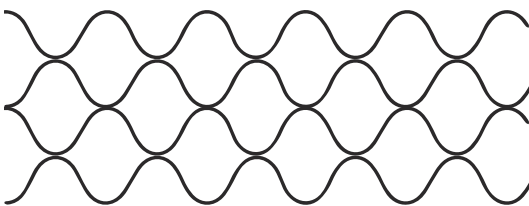

Symmetric plates are always forming symmetric channels.

Symmetric channels with asymmetric plates

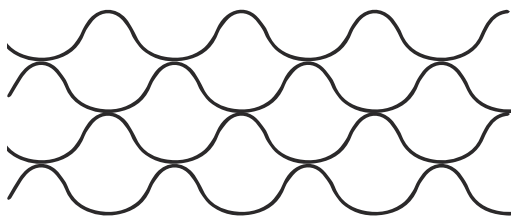

Also with asymmetric plates it is possible to make symmetric channels. Each channel is then facing the narrow side of one plate and the wide side of another plate.

Asymmetric channels with asymmetric plates

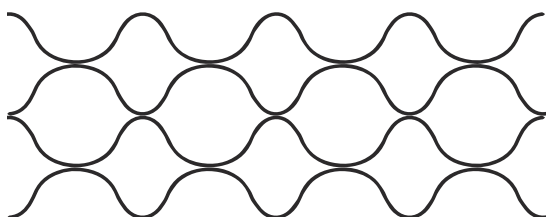

The asymmetric channel configuration is achieved when every second plate is flipped so that every second channel is only facing narrow sides of plates and every second channel is only facing wide sides of plates.

It is good to know that the collar of the plate is always folded from the wide side against the narrow side.

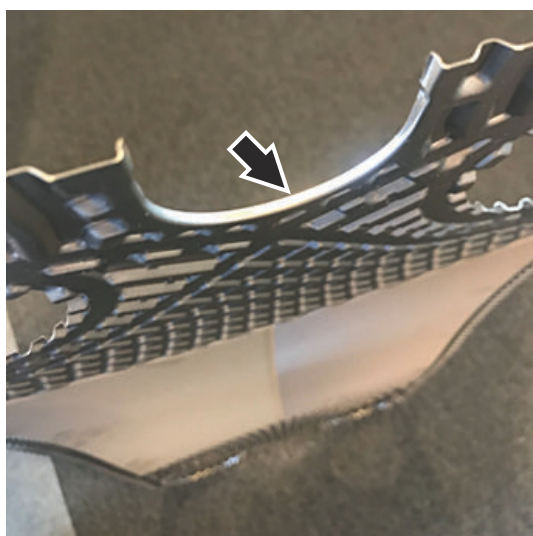

3.5 Plate hanging list

The *Plate hanging list* describes the way gaskets should be assembled on the plate and in which order and direction the gasketed plates should be hung on the carrying bar.

The *Plate hanging list* consists of all plates included in the plate package, listed from the frame plate to the pressure plate. If the plate heat exchanger has several sections, the plates are listed section-wise from the frame plate to the pressure plate.

3.5.1 Quick guide for plate hanging

By systematically following these steps, the plates will be correctly hung:

1. With help of marking on the plates and gaskets, identify which gaskets that should be assembled on which plates, see *Plate and gasket summary* in the *Plate hanging list*.
2. For symmetric plates, the gaskets are always assembled on the side of the plate that is marked with the plate name and the letter A, see Section [Plate identification](#). For asymmetric plates, check in the *Plate hanging list* if the gaskets should be assembled on the wide or the narrow side.
3. Assemble the gaskets accordingly.
4. In the *Plate hanging list*, find the sentence *Channel plates are assembled with the gasket side facing the [frame/pressure] plate* and note if the frame plate or the pressure plate is stated.
5. Note in the *Plate hanging list* if the A or the B end of the plate is pointing upwards.
6. Hang the plates into the heat exchanger according to the sequence presented in the *Plate hanging list*. That means with either the A or the B end pointing upwards, and with the gasket side of the channel plates correctly faced.
7. Pay special attention to end plates, and plates next to where the fluid is turning in multipass or multisection configurations. These plates may have gaskets on both sides, as illustrated in the *Plate hanging list*.

3.5.2 How to interpret the denomination

Here is an example of a row in the *Plate hanging list* and how to interpret it. See also section [Plate identification](#).

Plate I: DR6 P1 316 0.6 NBRB 1234 B W

Plate I	DR6	P1	316	0.6	NBRB	1234	B	W
1	2	3	4	5	6	7	8	9
Complete plate	Name of plate	Name of plate variant and chevron angle type	Plate material	Plate thickness	Gasket material	Port holes in plate	Plate end pointing upwards	Gasket assembled on this side of the plate

The significance of each part of the text string is:

1. Complete plate
See separate table *Plate and gasket summary* in the *Plate hanging list*.
2. Name of plate
3. Name of plate variant and chevron angle type
4. Plate material
5. Plate thickness in mm
6. Gasket material

7. Port holes in plate

The numbers tell in which positions there are holes, see image. To identify the hole positions, rotate or imagine the plate as follows:

- Find the marking of the plate name and the letter A on one of the short ends of the plate, see Section *Plate identification*.
- View the plate so that this marking is facing up with the A end pointing upwards.

1234 means that there are holes in all four positions. A zero (0) means that there is no hole. For example, 1204 means that there is no hole in position number 3. Note that the numbering of the hole configuration of a plate should not be confused with the numbering of the connections, S1, S2, T1, T2 etc. Depending on how the plate is flipped and turned when hung into the heat exchanger according to the *Plate hanging list*, a plate hole can be exposed to fluids from either of the connections.

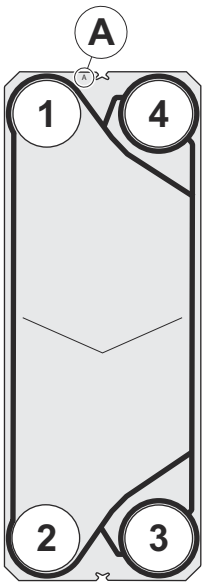

8. Plate end pointing upwards

Defines which end (A or B) of the plate that is pointing upwards when hung in the heat exchanger.

9. For asymmetric plate, gasket assembled on this side of the plate

Defines on which side of the plate the gasket should be assembled. This reference is only applicable for asymmetric plates.

3.5.3 How to interpret the illustration

The plate package is visualized in the *Plate hanging list* with symbols.

Positions for connections on frame plate (S1-S4) and pressure plate (T1-T4) respectively.

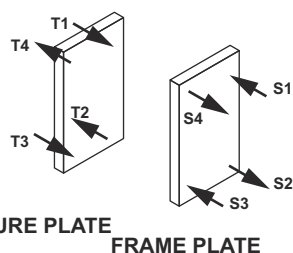

PRESSURE PLATE

FRAME PLATE

Symbol	Description
	Frame or pressure plate.
	Frame or pressure plate with 4 holes.
	Frame or pressure plate with 2 holes and 2 positions with blind cover.
	Plate.
	Plate with 3 holes and 1 position that is unholed.
	Field gaskets are visualized as flaps that enclose two plate holes. Ring gaskets are visualized as flaps that individually enclose one hole each.
	Plate with 2 holes and gaskets assembled on both sides of the plate.
	Semi-welded cassette. The welded channel is inside the bar.
	Partition plate, example with 2 holes.
	Connection plate with 4 holes.
	Vertical (V) and horizontal (H) connections respectively.
	Dot (●) for fluid moving towards the reader, and a cross (✕) for fluid moving away from the reader.
	Plate with drain or vent. The number is referring to the position S1-S4 (S2 in this example).

3.6 External inspection of a plate package

By inspecting the exterior of the plate package it is possible to identify if the configuration is symmetric or asymmetric, and it is also possible to discover mistakes in the plate hanging.

The side of the plate package

When viewed from the side, and if the plates are correctly hung according to the plate hanging list, the edges will form a honeycomb pattern, see image to the left below. If there are irregularities as in the image to the right below, there have been mistakes in the plate hanging.

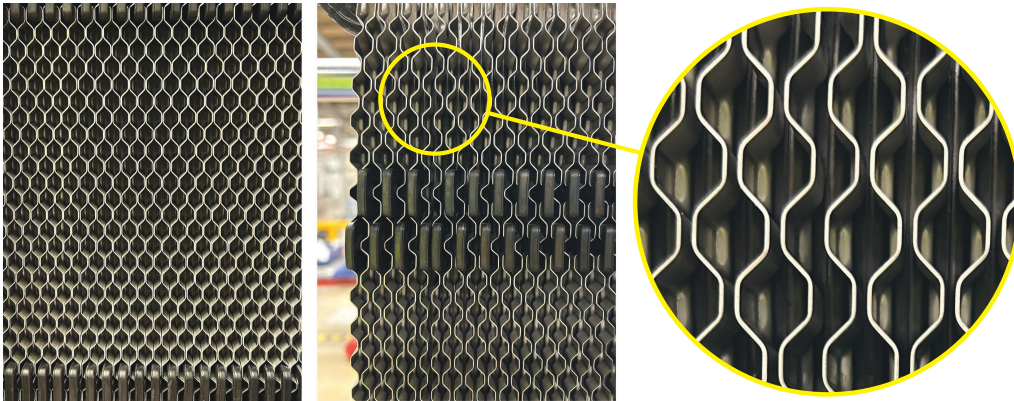

The corners of the plate package

Symmetric plates and asymmetric plates with symmetric configuration will have the corners of the plates at equal distances from each other, see image below.

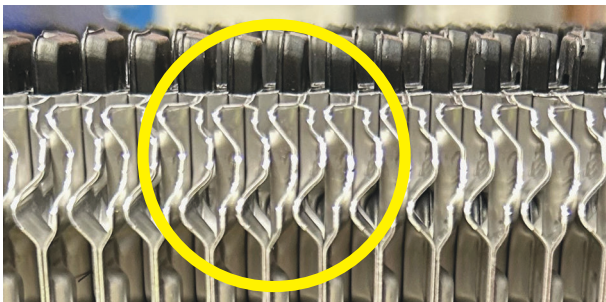

Asymmetric plates with asymmetric configuration will have the corners of the plates as in the image below. Two plates are close to each other and then there is a longer distance to the next pair of plates.

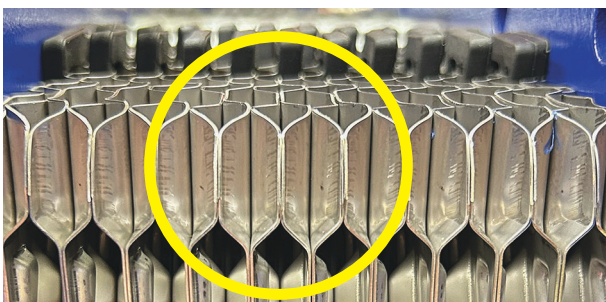

3.7 Bolt configuration

The bolt configuration of the plate heat exchanger varies between different models but it always consists of tightening bolts (TB) and locking bolts (LB).

The locking bolts can be shorter and can have smaller dimensions than the tightening bolts. In the opening and closing procedure, it is important to identify the tightening bolts and the locking bolts. See the illustration examples below.

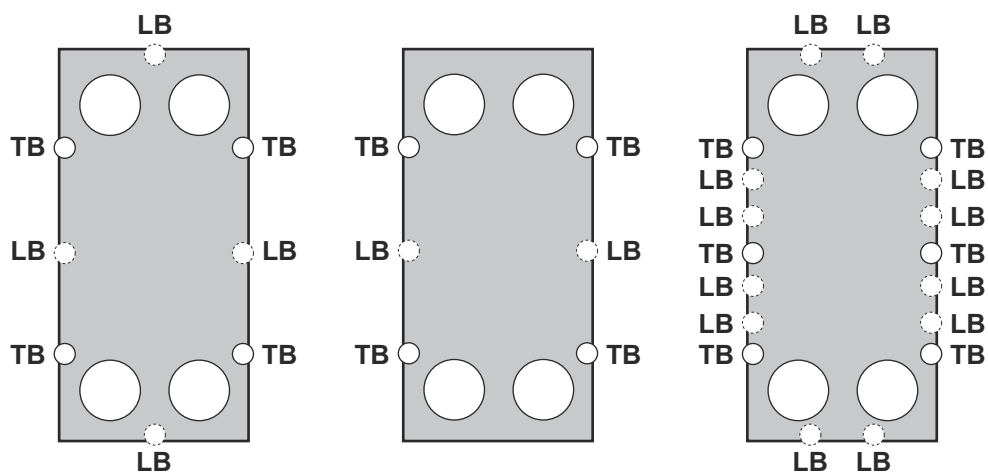

3.8 Function

The gasketed plate heat exchanger consists of a package of corrugated metal plates with portholes for the inlet and outlet of the fluids. The heat transfer between the fluids takes place through the plates.

The plate package is assembled between a frame plate and a pressure plate and compressed by tightening bolts. The plates are equipped with gaskets which seal the channels and direct the fluids into alternate channels. The plate corrugation promotes fluid turbulence and supports the plates against differential pressure.

3.8.1 Configuration with single pass

The most common set-up is with configuration in single pass (1-pass) according to the image below. The gaskets are in most cases facing the frame plate, but for some models the gaskets are facing the pressure plate.

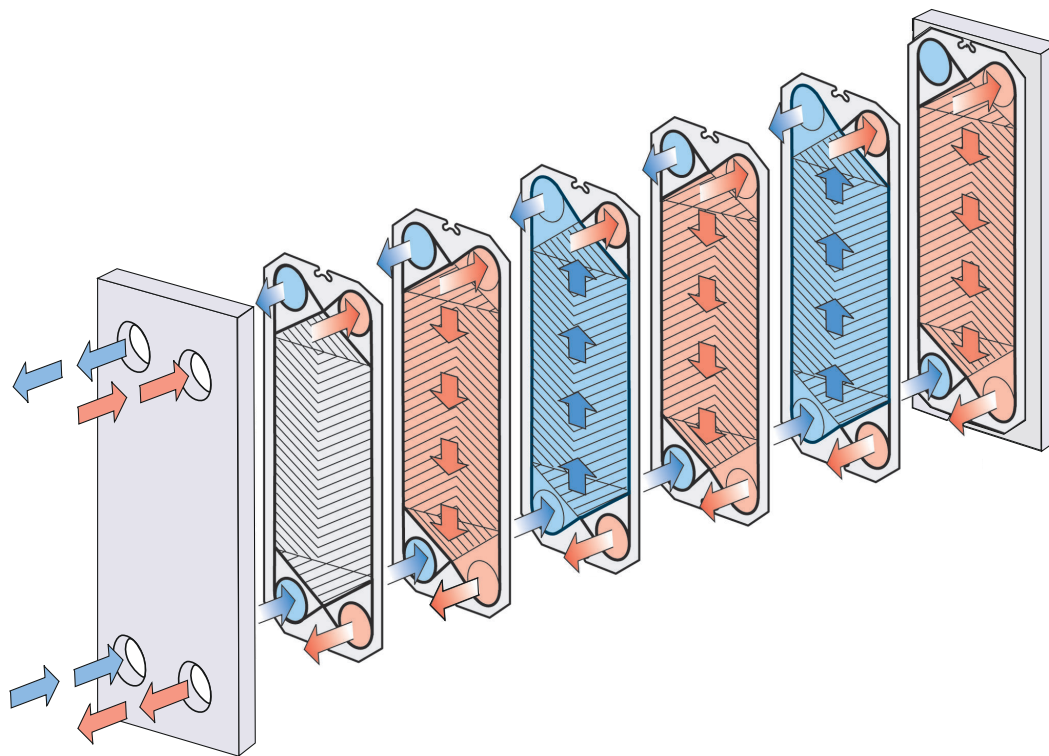

Example of a single-pass set up with gaskets facing the frame plate.

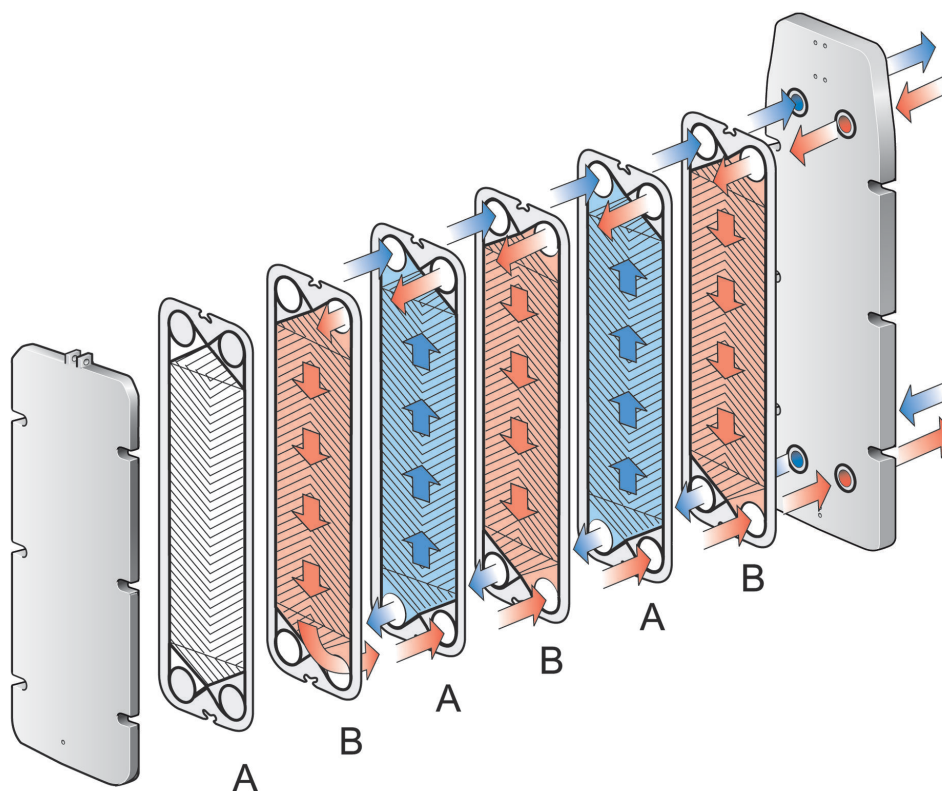

Example of a single-pass set up with gaskets facing the pressure plate.

3.8.2 Configuration with semi-welded cassettes

In semi-welded heat exchangers, the plates are arranged with cassettes (twin plates) in such a way that every second channel is sealed by means of a laser-weld, and every other channel is sealed using gaskets. The working principle is the same as for fully gasketed 1-pass configuration, but there are two types of channels. The laser-welded channel is used for aggressive media and/or when extra high design pressure is required. The fully gasketed channel is used for non-aggressive secondary media. Note that the ring gaskets used to seal the laser-welded channel are in contact with the fluid in the laser-welded channel.

NOTE Refrigeration

For refrigeration duties the end cassette channels might be blinded to reduce the fluid flow through the first and last channel.

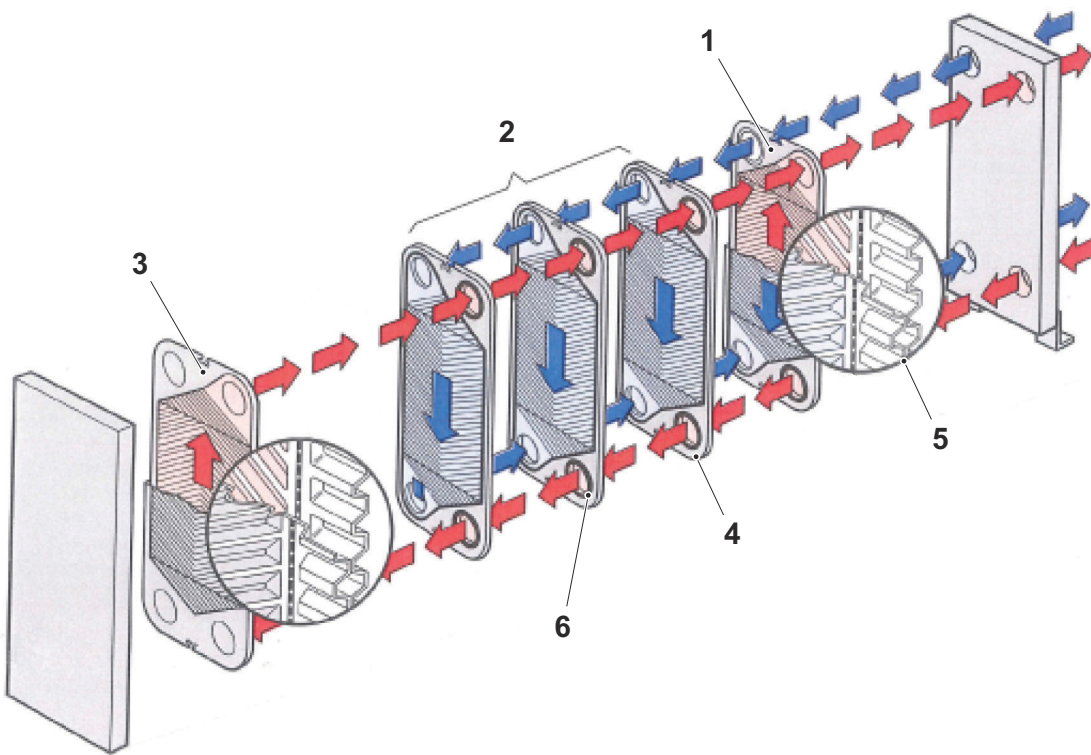

Figure 1: Example of a semi-welded configuration.

1. End cassette I. End single plate if M10-BWREF.
2. Channel cassettes
3. End cassette II. End single plate if M10-BWREF
4. Gasketed channel created between two cassettes (blue)
5. Two plates which form the welded channel inside the cassette (red)
6. Ring gasket sealing between laser-welded and gasketed channel

3.8.3 Configuration with multi-pass

Multi-pass can be configured using turning plates with one or several unholed ports. The purpose is to allow one or both fluids taking several turns in the heat exchanger.

For some units, a partition plate is required to support the unholed ports in the turning plates. A transition plate is also needed to prevent media from getting in contact with the partition plate or the pressure plate. See the plate hanging list for details.

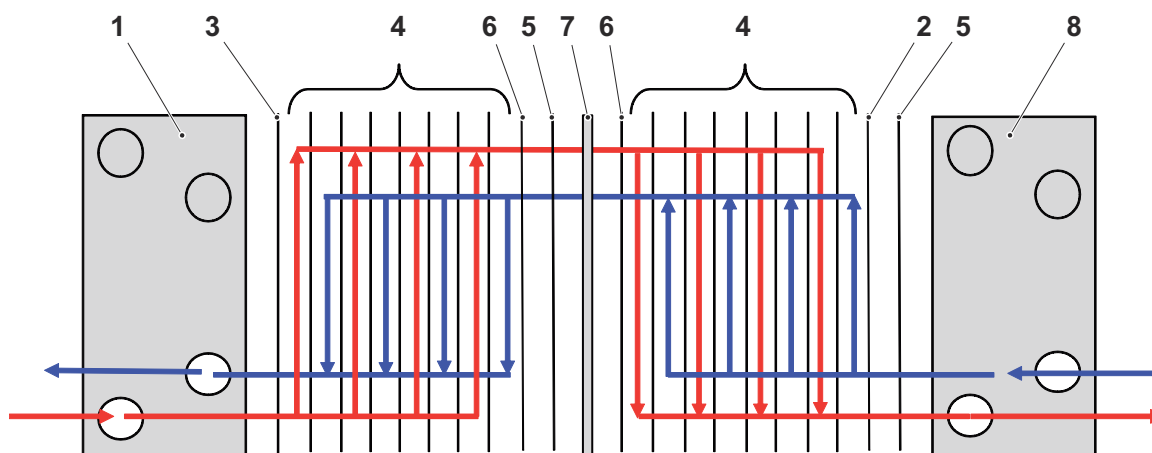

Example of a multi-pass configuration.*

1. Frame plate
2. End plate I
3. End plate II
4. Channel plates
5. Transition plate
6. Turning plate
7. Partition plate
8. Pressure plate

*) Note that all types of plates are not necessarily included in a multi-pass configuration.

3.8.4 Configuration with multi-section

A multi-section heat exchanger is configured for handling 3 or more media. An example of multi-section configuration is when a media needs to be heated in one stage and then cooled down in the next stage.

A multi-section plate heat exchanger can be set up by using connection plates. The connection plates can be configured for different corner connections such as single, double, pass-through or blind.

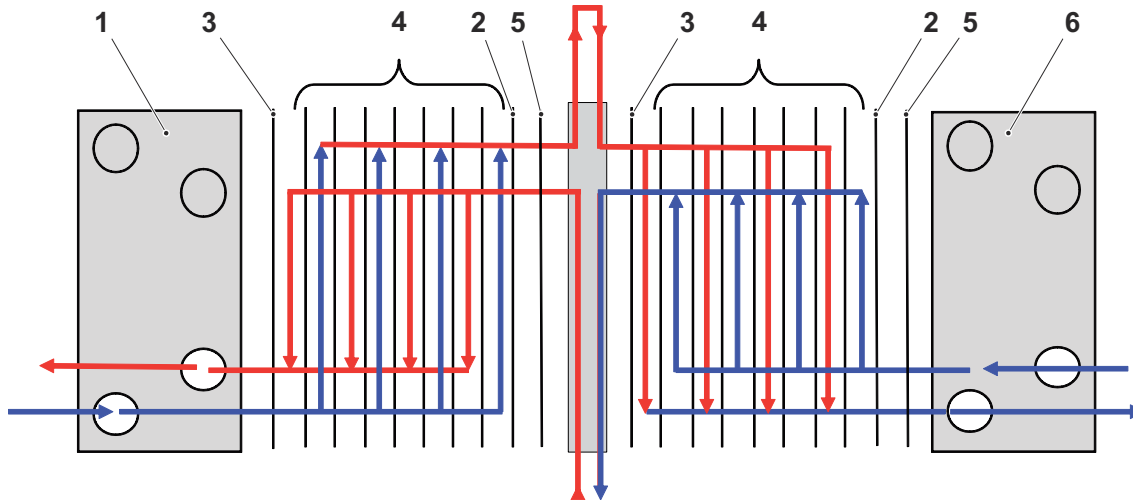

Example of a multi-section configuration.

1. Frame plate
2. End plate I
3. End plate II
4. Channel plates
5. Transition plate
6. Pressure plate

4 Maintenance

This chapter describes all maintenance procedures necessary.

4.1 Plate heat exchanger

This section consists of maintenance performed on a complete unit.

4.1.1 Plate heat exchanger — Drain

NOTE Risk of personal injury.

The plate heat exchanger should not be in operation and it must not be pressurised.

WARNING Risk of personal injury.

Use proper protective equipment. See Section *Personal protective equipment* in Chapter *Safety*.

NOTE The plate heat exchanger contains media (liquid).

It is recommended to connect the plate heat exchanger to a draining system.

1 Make sure all valves and pumps are closed.

2 Drain the plate heat exchanger through a draining system so that the media can be taken care of according to local regulations.

3

NOTE

Depending on size and configuration a plate heat exchanger can contain from 0.14 litre up to 6220 litre of liquid.

Make sure that all liquid inside the plate heat exchanger can be taken care of.

Remove the lower port hole connection and let the media discharge from the plate heat exchanger.

4.1.2 Plate heat exchanger — Open

To manually clean the plates, to change a plate, or to change a gasket, it is necessary to open the plate heat exchanger.

NOTE

Before opening the plate heat exchanger, check the warranty conditions. If in any doubt, contact the Alfa Laval sales representative. See Section [Warranty conditions](#) in Chapter [Introduction](#).

WARNING Risk of personal injury.

The plate heat exchanger can be hot.

Wait until the plate heat exchanger has cooled down to about 40 °C (104 °F).

WARNING Risk of personal injury.

Use proper protective equipment. See Section [Personal protective equipment](#) in Chapter [Safety](#).

1

NOTE

Even if the plate heat exchanger is drained at the lower connections, a substantial amount of media can still remain in multi-pass configurations.

Drain the plate heat exchanger according to Section [Plate heat exchanger - Drain](#).

2 Remove any protection sheets.

3 Remove connections and pipes so that the pressure plate is free to move along the carrying bar.

4 Inspect the sliding surfaces of the carrying bar. Wipe the sliding surfaces clean and put grease on them.

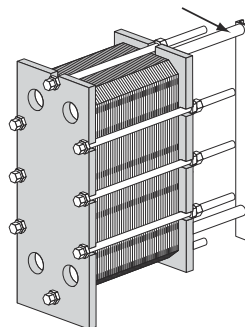

- 5 Draw a diagonal line on the outside of the plate package.

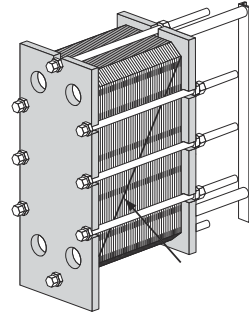

- 6 Check and note the A-measurement.

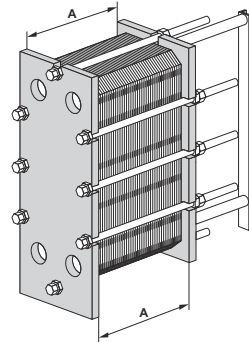

- 7** The plate heat exchanger can have different kinds of feet or no feet at all. Follow the sub-instruction corresponding to your installation. If there is a support foot under the guiding bar, mark the position on the floor. This support foot must not be removed and it should be in the same position after the plate heat exchanger has been opened.

- a) Remove the foundation screws from the feet at the pressure plate. Remove the feet.

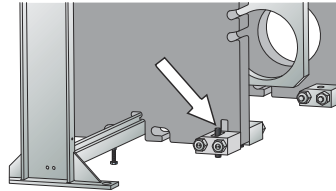

- b) Remove the nuts and screws that connect the feet against the pressure plate. Remove the feet.

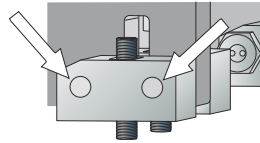

- c) Remove the outer feet. The pressure plate has a slot which makes it possible to pass the protruding foundation screw.

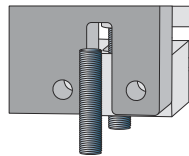

- d) Loosen and remove the feet at pressure plate. Loosen the nuts of the foundation bolts located at the outside. Remove the nuts and bolts that connect the feet against the pressure plate. Swing out the outer feet.

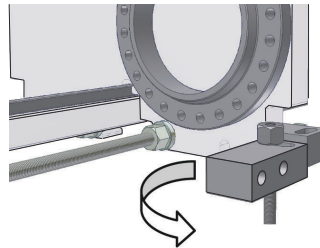

- 8** Loosen and remove the locking bolts.

- 9** Brush the threads of the tightening bolts with a steel wire brush.

- 10** Put grease on the threads of the tightening bolts.

- 11** Loosen the tightening bolts to open the plate package. During the opening procedure, keep the frame plate and pressure plate parallel. Skewing of the pressure plate during opening must not exceed 10 mm (2 turns per bolt) across the width and 25 mm (5 turns per bolt) vertically.

-
- 12 Remove the tightening bolts when possible.
 - 13 Gently push the pressure plate away from the frame plate.
 - 14 Now it is possible to open the plate package.
-

4.1.3 Tightening torque

When a pneumatic tightening device is used, see the table corresponding to your plate heat exchanger for maximum torque. Check the A-measurement during tightening.



NOTE The A-measurement is the important value.

Torques stated in this table are only referring to the maximum value to which a bolt can be torqued. You must always check the A-measurement when tightening the bolts and never tighten more when the A-measurement is reached.

Bolt size	Bolt with bearing box		Bolt with washer	
	Nm	kpm	Nm	kpm
M10	—	—	32	3.2
M16	—	—	135	13.5
M20	—	—	265	26.5
M24	—	—	450	45
M30	585	58	900	90
M39	1300	130	2000	200
M48	2100	210	3300	330
M52	2100	210	3300	330

4.1.4 Plate heat exchanger — Close

NOTE This section is not valid for hard gasket materials.

For hard gasket materials, for example EPDMAL, HNBRAL and FKMAL, follow the instructions in Section [Hard gasket materials](#).

NOTE Risk of damage to equipment.

Note maximum bolt torque values in Section [Tightening torque](#).

NOTE The A-measurement is the important value.

Torques stated in Section [Tightening torque](#) table are only referring to the maximum value to which a bolt can be torqued. Always check the A-measurement and never tighten more when the A-measurement is reached.

Follow the instructions to ensure that the plate heat exchanger will be properly closed.

For bolt identification, see Section [Bolt configuration](#).

If there is a support foot under the guiding bar make sure it is in the correct position. It is a recommendation to mark the position of the support foot before the plate heat exchanger is opened. If this has not been done, see the plate heat exchanger drawing for the correct measure.

1 Check that all the sealing surfaces are clean.

2 Brush the threads of the bolts clean, using a steel wire brush or the Alfa Laval thread cleaner. Lubricate the threads with a thin layer of grease.

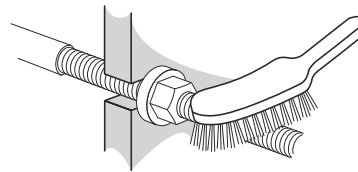

3 **NOTE**
If a gasket is wrongly positioned, there is risk of gasket damage or poor sealing function.

Check that all gaskets are properly attached.
Check that all gaskets are correctly positioned in the gasket grooves.

4 Press the plate package together.

5 Tighten the tightening bolts crosswise until the plate package measure is $1.2 \times A$ making sure the frame plate and pressure plate are parallel when closing. To reduce gasket forces and allow gasket relaxation, slow tightening (3-4 rpm) is recommended.

-
- 6 To prevent misalignment that can occur during tightening the plate heat exchanger can be heated with 30 °C to 40 °C (85 °F to 105 °F) water. Proceed to complete the tightening of the somewhat softened gaskets as outlined. Allow water to drain or keep the ventilation valve open during tightening.
-
- 7 If possible, let the plate package rest for at least one hour so that all plates and gaskets can settle.
-
- 8 Tighten all the bolts crosswise until the A-measurement has been reached.
-
- 9 If the A-measurement cannot be reached:
- Check the number of plates.
 - Check that all the nuts and bearing boxes (if applicable) are running freely. If not, clean and lubricate, or replace.
-

10

**Only valid for TL6**

When using an ASME standard frame.

Plate heat exchangers with pressure vessel code ASME are equipped with top and bottom bolts. Tighten those bolts after the procedure above has been finished or slightly before the A-measurement is reached.

- 11 If applicable, install the protection sheets.
-
- 12 Connect the pipes.
-
- 13 Assemble the feet to the pressure plate.
-
- 14 Perform a hydrostatic leakage test.
-

4.1.4.1 Hard gasket materials

NOTE This section is only valid for hard gasket materials, such as EPDMAL, HNBRAL and FKMAL.

For other gasket materials follow the instructions in Section [Plate heat exchanger - Close](#).

For hard gasket materials the gasket compression must be handled carefully. Improper gasket compression can cause gasket crushing or plate deformation.

The tightening procedure is critical to the lifetime of the plate and gasket. If the procedure is done too quickly the result could be either deformed plates that will not seal or fractured gaskets that will lead to premature gasket failure.

This procedure should, if possible, be carried out at temperatures of 18 °C (65 °F) or higher.

Check the A-measurement frequently during the tightening procedure. Skewing of the pressure plate must not exceed 10 mm (2 turns per bolt) across the width and 25 mm (5 turns per bolt) vertically.

NOTE Risk of damage to equipment.

Note maximum bolt torque values in Section [Tightening torque](#).

NOTE The A-measurement is the important value.

Torques stated in Section [Tightening torque](#) table are only referring to the maximum value to which a bolt can be torqued. Always check the A-measurement when tightening the bolts and never tighten more when the A-measurement is reached.

Follow the instructions to ensure that the plate heat exchanger will be properly closed.

For bolt identification, see Section [Bolt configuration](#).

1 Check that all the sealing surfaces are clean.

2 Brush the threads of the bolts clean, using a steel wire brush or the Alfa Laval thread cleaner. Lubricate the threads with a thin layer of grease.

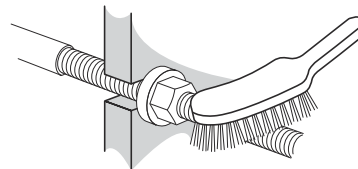

3 **NOTE** If a gasket is wrongly positioned, there is risk of gasket damage or poor sealing function.

Check that all gaskets are properly attached.
Check that all gaskets are correctly positioned in the gasket grooves.

4 Press the plate package together.

- 5 Tighten the tightening bolts crosswise until the plate package measure is $1.2 \times A$ making sure the frame plate and pressure plate are parallel when closing. To reduce gasket forces and allow gasket relaxation, slow tightening (3-4 rpm) is recommended.
 - 6 To prevent misalignment that can occur during tightening the plate heat exchanger can be heated with 30 °C to 40 °C (85 °F to 105 °F) water. Proceed to complete the tightening of the somewhat softened gaskets as outlined. Allow water to drain or keep the ventilation valve open during tightening.
 - 7 Allow the plate package to rest for at least one hour.
 - 8 At reduced tightening speed (1-2 rpm), tighten all the bolts crosswise until the plate package measure is $1.05 \times A$ making sure the frame plate and pressure plate are parallel when closing.
 - 9 Allow the plate package to rest for at least one hour.
 - 10 At reduced tightening speed (1-2 rpm), tighten all the bolts crosswise to the A-measurement.
 - 11 If the A-measurement cannot be reached:
 - a) Check the number of plates.
 - b) Check that all the nuts and bearing boxes (if applicable) are running freely. If not, clean and lubricate, or replace.
 - 12 If applicable, install the protection sheets.
 - 13 Connect the pipes.
 - 14 Assemble the feet to the pressure plate.
 - 15 Perform a hydrostatic leakage test.
-

4.1.5 Removal, lifting and insertion of plates in the field

⚠ WARNING Risk of personal injury.

Handling of plates should be avoided in windy conditions.

Be aware of sharp edges. Protective gloves should always be worn.

Lifting in edges around the portholes shall be avoided.

1 Open the plate package. See Section [Open](#).

2 Each plate shall be removed one by one. For safe removal and lifting of large plates a lifting device can be used.

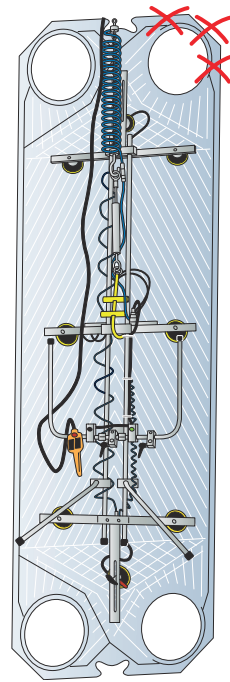

3 Lifting of a single plate shall be done in a controlled way.

4 Insert the plates according to the plate hanging list.

5 When closing, the plates shall be pressed towards the frame plate, preferably by holding a tool on the upper part of the plate and gently pushing it.

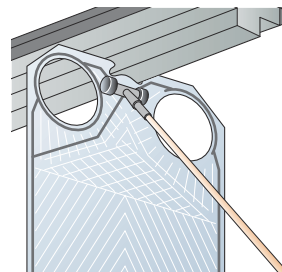

6 Close the plate package. See Section [Close](#).

4.1.6 Leakage test

The processes described for pressure testing are only allowed to be performed by authorized personnel according to local laws and regulations and following applicable standards.

If no such person is internally available, a third party authorized entrepreneur working per local legislation using proper equipment shall be engaged.

Before the start-up of production, whenever plates or gaskets have been removed, inserted or exchanged, it is strongly recommended to perform a hydrostatic leakage test to confirm the internal and external sealing function of the plate heat exchanger. In this test, one media side at a time must be tested with the other side open to the ambient pressure. In a multi-section configuration, all sections of the same side must be tested simultaneously. The recommended test time is 10 minutes for each media side.

 **CAUTION Risk of damage to equipment.**

The recommended pressure for the leakage test is a pressure equal to the operating pressure + 10%, but never above the design pressure as stated on the type plate.

 **CAUTION Risk of damage to equipment.**

Please note that semi-welded plate heat exchangers for refrigeration applications and units with media not mixable with water must be dried after hydrostatic leakage testing.

 **WARNING Risk of personal injury.**

Testing by putting gas (compressible media) under pressure can be very dangerous. Local laws and regulations regarding to the hazard involved in testing with a compressible medium must be respected. Hazardous examples are explosion risk due to uncontrolled medium expansion and/or suffocation risk due to oxygen depletion.

 **WARNING Risk of damage to equipment.**

Any rebuilding or modification of the plate heat exchanger is the responsibility of the end user. Regarding recertification and pressure test (PT) of the plate heat exchanger the local laws and regulations for in service inspection must be respected. Example of rebuilding is if more plates are added to the plate package.

If there is any uncertainty about the testing procedure of the plate heat exchanger, consult an Alfa Laval representative.

4.1.7 Cleaning

For the heat transfer efficiency, it is very important to keep the heat exchanger plates clean. Depending on application, cleaning is needed with different frequencies.

NOTE

The procedures and recommendations described in this section are typical and valid in most cases. Depending on application, other recommendations may apply.

To minimize the need for cleaning it is always recommended to secure that the installation and the operation are performed in the most optimal way. Things to consider are for example:

- Filters and strainers to prevent major debris from entering the heat exchanger.
- Quality and hardness of cooling water to minimize scaling.
- Operation with good turbulence of the fluids to avoid stagnant zones in the heat exchanger.
- Precaution on temperature programs for heat sensitive fluids.
- Backflushing for fluids containing particles and fibres.

Clean processes may rarely need any cleaning. Processes in food applications may for hygienic reasons need frequent cleaning. Some processes are, regardless of precautions taken, causing inevitable fouling, and cleaning has then to be regularly planned for.

There are two principal methods of cleaning:

- Cleaning-In-Place (CIP)
- Manual (mechanical) cleaning

If physically possible, CIP is always the preferred and most economical choice. CIP is faster, requires less downtime and manhours, and consumes less chemicals and water compared to manual cleaning. With CIP there is also less risk of damaging the plates or gaskets, as the heat exchanger is kept closed. For very severe fouling or if the fouling consists of insoluble substances, then manual cleaning that requires opening of the heat exchanger may be the only choice. For manual cleaning it is recommended to use the services, including reconditioning of plates, provided by the Alfa Laval Service Centers.

4.1.7.1 Cleaning agents

⚠ WARNING Risk of personal injury.

Corrosive cleaning liquids. Can cause serious injuries to skin and eyes.

Use proper personal protective equipment when using the cleaning agents. See Section [Personal protective equipment](#) in Chapter [Safety](#).

⚠ WARNING Risk of personal injury.

The residuals after a cleaning procedure shall be handled according to local environmental regulations. Provided that the fouling deposits do not contain heavy metals or other toxic or environmentally dangerous compounds, most cleaning solutions may after neutralization be drained into the waste water system. Prior to disposal, it is recommended to analyse the neutralized chemicals for any hazardous compounds that were removed from the system.

Alfa Laval provides the cleaning agents listed in the table.

Liquid	Description
AlfaCaus	A strong alkaline liquid, for removing organic material like fat, oil and biological deposits.
AlfaPhos	An acid cleaning liquid for removing inorganic material like metallic oxides, rust, lime and other inorganic scale. Contains corrosion inhibitor.
AlfaNeutra	A strong alkaline liquid for neutralization of AlfaPhos before drainage.
Alfa P-Scale	An acidic powder cleaner for the removal of primary carbonate scale but also other inorganic scale.
Alfa P-Neutra	For neutralization of Alfa P-Scale.
Alpacon Descalant III	A non-hazardous acidic cleaning agent for the removal of inorganic scale. Contains corrosion inhibitor.
Alpacon Degreaser III	A non-hazardous cleaning agent for the removal of oil, grease or wax deposits. Intended for manual cleaning. Can be used with Alpacon Descalant III to avoid foaming.
Alpacon Multi CIP II	A non-hazardous cleaning agent for the removal of oil grease or wax deposits. Intended for CIP.
AlfaAdd	A neutral cleaning strengthener designed to be used with AlfaPhos, AlfaCaus and Alfa P-Scale. 0.5–1 vol% is added to the total diluted cleaning solution to provide better cleaning results on oily and fatty surfaces and where biological growth occurs. AlfaAdd also reduces foaming.

Chlorine as a growth inhibitor



CAUTION Risk of personal injury.

Ensure that the handling of residuals after using chlorines follow local environmental regulations.

Chlorine, commonly used as a growth inhibitor in cooling water systems, reduces the corrosion resistance of stainless steels (including high alloys like Alloy 254).

Chlorine weakens the protection layer of these steels making them more susceptible to corrosion attacks than they otherwise would be. It is a matter of time of exposure and concentration.

Water of more than 330 ppm chlorine ions may not be used in the preparation of cleaning solutions.



NOTE Titanium alloys are not affected by chlorine.

4.1.7.2 Cleaning-In-Place (CIP)

The cleaning-in-place (CIP) procedure allows cleaning of the plate heat exchanger without opening it. The purpose of cleaning with CIP is as follows:

- Cleaning of fouling built-up on the plate heat exchanger plates
- Cleaning of bacteria in hygienic processes

CIP equipment

Many processes have built-in CIP equipment and cleaning procedures tailor made for their processes. Alfa Laval provides portable CIP equipment of different sizes and can recommend CIP cleaning cycles. For instructions of the CIP equipment, see separate manual. Contact an Alfa Laval sales representative for sizing of CIP equipment.



⚠ WARNING Risk of personal injury.

Use proper personal protective equipment when using the cleaning agents. See Section [Personal protective equipment](#) in Chapter [Safety](#).

⚠ WARNING Risk of personal injury.

Corrosive cleaning liquids. Can cause serious injuries to skin and eyes.

Use proper personal protective equipment. See Section [Personal protective equipment](#) in Chapter [Safety](#).

Examples of cleaning cycles

Depending on application and frequency of cleaning, the cleaning agents and the cycle times may vary. Note that the heat exchanger shouldn't be left filled with cleaning agents for a prolonged time. The cycle times are normally not longer than indicated in the examples, and they are always followed by rinsing.

Below are a few typical examples of cleaning by means of CIP. These are meant as examples only, and the cleaning procedures must be validated for each installation. This is particularly important for hygienic applications. See also separate manual for CIP equipment. Contact Alfa Laval for more information or recommendations for specific applications.

Example 1: Fouling from cooling water in industrial application

Cooling water can cause fouling of various types. Organic substances are dissolved by alkaline cleaning agents and scaling from salts are dissolved by acidic cleaning agents.

A cleaning cycle can typically be:

1. Rinsing with water 30 minutes
2. Circulating AlfaCaus 10% at 70 °C for up to 4 hours
3. Rinsing with water 30 minutes
4. Circulating AlfaPhos 10% at 70 °C for up to 4 hours
5. Rinsing with water 30 minutes

Depending on the type of fouling and frequency of cleaning, the cycle times can be substantially shorter.

Example 2: Cleaning in hygienic applications

When circulating cleaning solutions, it is recommended to use at least the same flow rate as the production's flow rate. Refer to the order documentation for recommended flow rate during cleaning.

The concentration of cleaning agent, the temperature and the circulating time are dependent on the products that are being processed. The higher the concentration of proteins, fats and insoluble components in the product, the higher cleaning liquid concentration, and the longer cleaning times are required. Do not exceed the concentrations and temperatures recommended, as this may damage the plates or gaskets.

Alkaline cleaning agents, like for example sodium hydroxide (NaOH) and potassium hydroxide (KOH), are used for removal of fats which are converted to soaps and rinsed with water. 0.15-5% of alkali detergent at 70-80 °C for 10-30 minutes are usually recommended.

Acidic cleaning agents, like for example nitric acid (HNO₃) and phosphoric acid (H₃PO₄), are used for removal of residual alkaline cleaning agents, minerals and other inorganic fouling. 0.5-1% acidic detergent at 55-80 °C for 2-20 minutes are usually recommended.

A final sterilization is sometimes done after the cleaning, or prior to starting up a new production cycle. Sterilization is either done by circulating hot water (90 °C or higher), or by circulating for example a sodium hypochlorite (NaClO) solution 0.1-0.15% (pH 6-7) at room temperature followed by rinsing. The circulation time depends on the sanitizer used and the plant's requirements.

A cleaning sequence with cleaning agents, concentrations, temperatures and cycle times as described above can typically be:

1. Rinsing with water
2. Circulating alkaline detergent
3. Rinsing with water
4. Circulating acidic detergent

5. Rinsing with water
6. Sterilization

 **WARNING** Risk of personal injury.

The residuals after a cleaning procedure shall be handled according to local environmental regulations. After neutralization, and provided that the fouling deposits do not contain heavy metals or other toxic or environmentally dangerous compounds, most cleaning solutions may be drained into the waste water system. Prior to disposal, it is recommended to analyze the neutralized chemicals for any hazardous compounds that were removed from the system.

4.1.7.3 Manual (mechanical) cleaning

**CAUTION****Risk of damage to equipment.**

Never use hydrochloric acid with stainless steel plates. Water of more than 330 ppm Cl may not be used in the preparation of cleaning solutions.

It is very important that aluminium carrying bars and support columns are protected against chemicals.

**CAUTION****Risk of damage to equipment.**

Be careful not to damage the gasket during manual cleaning.

**WARNING****Risk of personal injury.**

Corrosive cleaning liquids. Can cause serious injuries to skin and eyes.

Use proper personal protective equipment when using the cleaning agents. See Section [Personal protective equipment](#) in Chapter [Safety](#).

In case Cleaning-In-Place (CIP) is not applicable or suitable, manual cleaning can be used. Manual cleaning is sometimes also referred to as mechanical cleaning.

In semi-welded heat exchangers, only the gasketed channel is accessible for this type of cleaning. The semi-welded channel can only be cleaned by means of CIP.

Follow the procedures for draining, opening and closing of the heat exchanger in this manual. Cleaning of the plates can be done with the plates kept hanging in the heat exchanger, or the plates can be disassembled. The cleaning can be done with help of water and a soft brush or a high pressure washer. Cleaning agents, see Section [Cleaning agents](#), can also be used. Make sure to immediately rinse properly, as cleaning agents can be harmful to the gasket glue.

Alfa Laval's Service Centers provide cleaning services, as well as reconditioning of plates.

4.1.8 Removable lifting equipment

Information and instructions regarding lifting can be found in the *Installation Manual*. This section contains instructions regarding handling of removable lifting equipment.

4.1.8.1 Removable lifting device

On delivery, and if included in the scope of supply, the lifting devices are mounted on the heat exchanger. It is recommended to let them remain on the heat exchanger.

This section describes how to assemble the lifting devices, if they for some reason have been disassembled.

4.1.8.1.1 Lifting devices — Assemble

⚠ WARNING Risk of personal injury.

The equipment is heavy.

Wear personal protective equipment when handling the equipment. Handle the equipment with precaution. See Section *Personal protective equipment* in Chapter *Safety*.

It is recommended that two persons execute the assembly and to use a hoist slings and lifting equipment like a fork lift truck or a overhead gantry. A hoist sling is used in this instruction.

The lifting devices are assembled from the outside of the upper corners of the frame plate and pressure plate respectively.

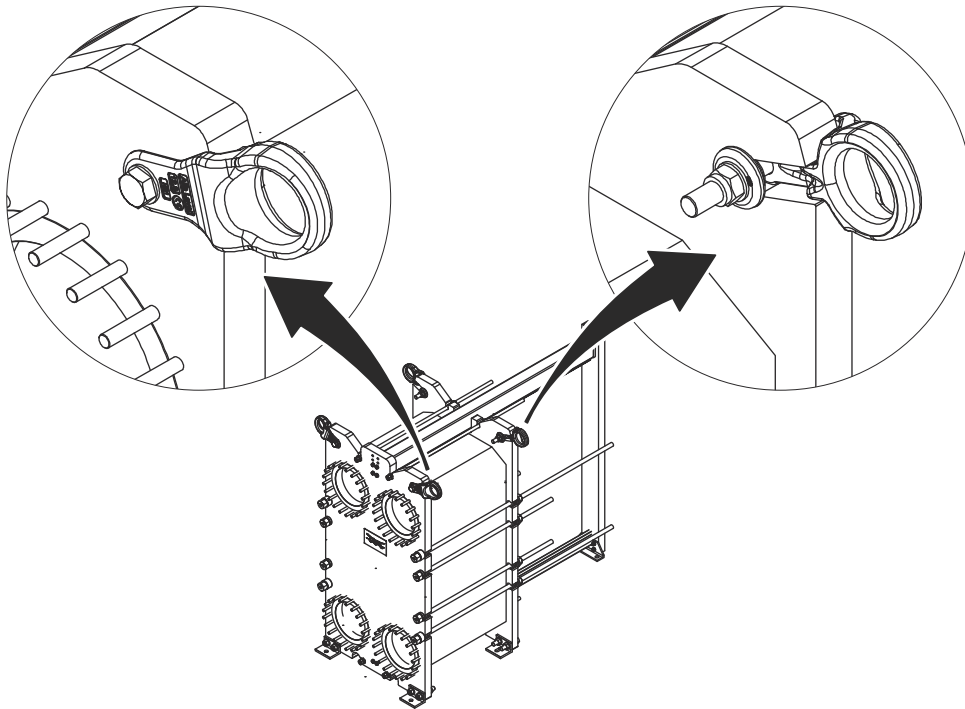

- 1 If applicable, remove the locking nut (6) using a nutrunner with a torque reaction bar, the screw (1), the washer (2), the guiding washer (4), and the washer (5) from the lifting eye (3). Use a wrench or adjustable spanner to prevent the screw (1) from rotating.

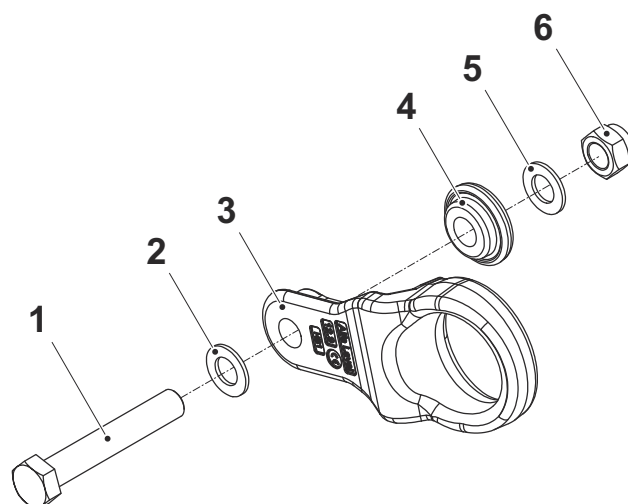

- 2 Attach a hoist sling to the lifting eye.

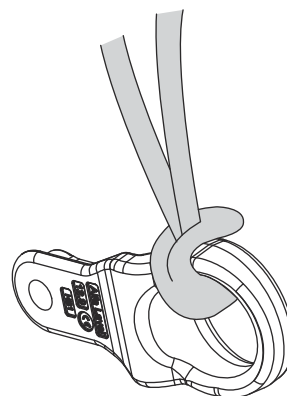

- 3 Gently lift the lifting eye in position at the plate heat exchanger.

- 4 Fit the guiding washer (4). Make sure it fits correctly in the lifting eye (3).

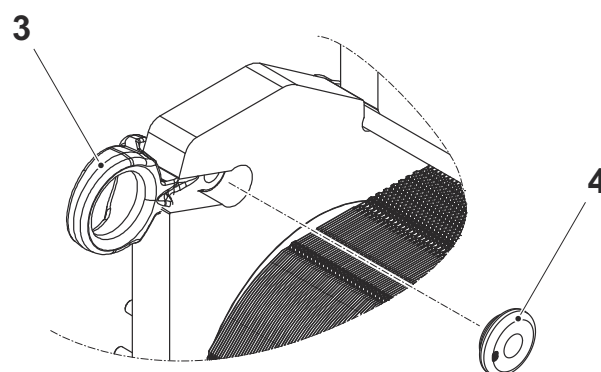

- 5 Fit the washer (2) and the screw (1).

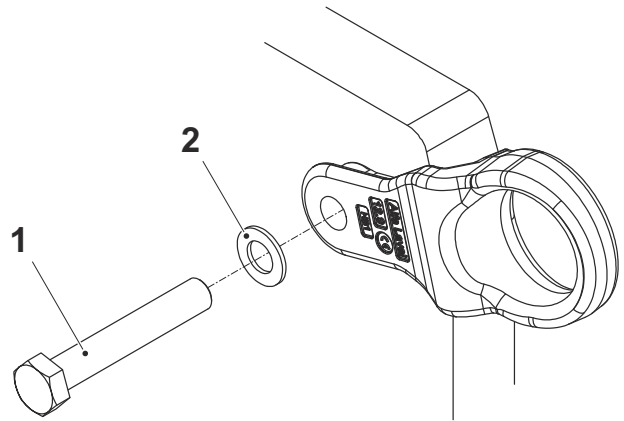

- 6 Fit the washer (5) and the locking nut (6).

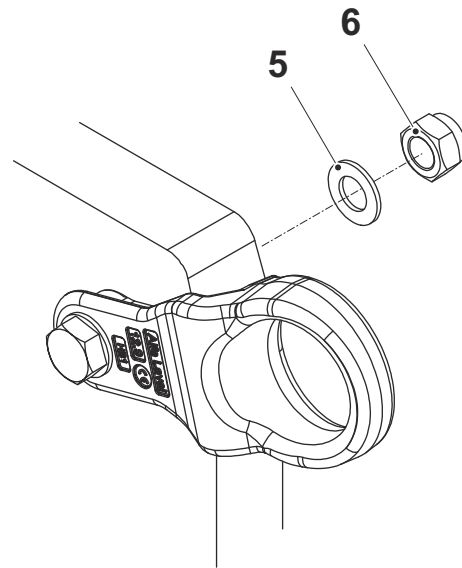

- 7 Tighten the locking nut firmly using a nutrunner with a torque reaction bar. Use a wrench or adjustable spanner to prevent the screw from rotating.

- 8 Remove the hoist sling.

- 9 Repeat the procedure on all lifting devices.

- 10 The plate heat exchanger can now be lifted according to the instruction for lifting using lifting devices in the *Installation Manual*.

4.2 Frame

This section describes maintenance of the plate heat exchanger frame.

4.2.1 Assembly of feet

Some hygienic plate heat exchangers are delivered with the feet disassembled. Follow the instruction below.



WARNING Risk of personal injury.

The equipment is heavy.

Be careful when handling the equipment. Do not reach in under equipment that is not secured.

Never work under hanging load.

Always make safety arrangement to avoid crushing.

- 1 Cover plates are on delivery attached to the frame plates and support column in the positions where the feet shall be assembled.
- 2 Lift the equipment according to Section *Lifting the equipment* in the *installation Manual*.
- 3 To minimize the risk of personal injury in case the equipment should accidentally fall, place wooden beams under the equipment.
- 4 Remove the screws, the washers, and the nuts and then remove the cover plates.

- 5 Use the same screws, washers and nuts to assemble the feet on the plate heat exchanger according to the picture.

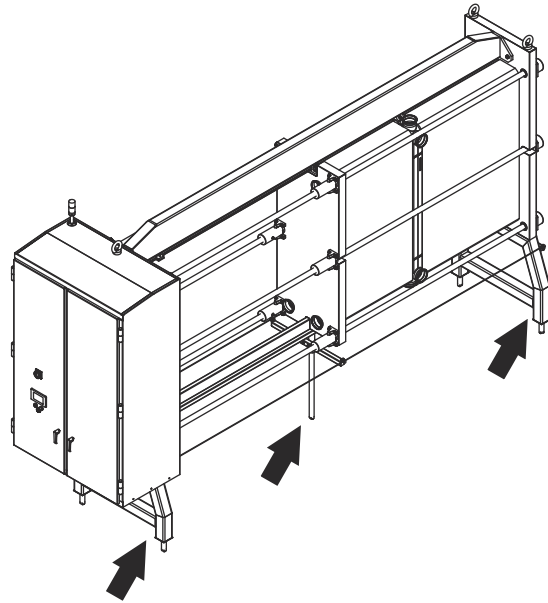
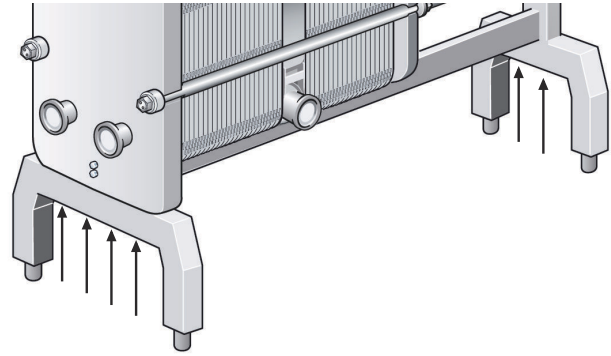

- 6 If the unit has two stabilising bars, assemble them according to the picture.

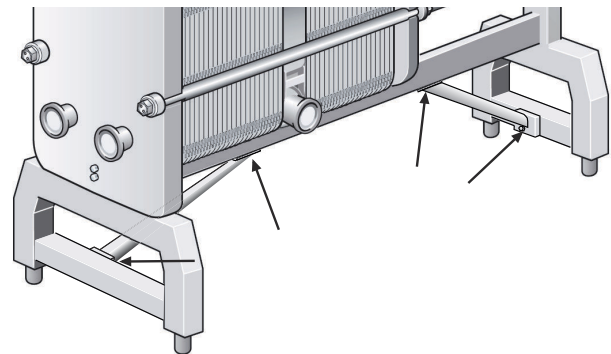

4.3 Plate

This section describes maintenance of the plate heat exchanger plates.

4.3.1 Replacement of a limited number of plates

 **CAUTION** Risk of personal injury.

Plates and protection sheets have sharp edges.

Wear personal protective equipment when handling the plates and the protection sheets. See Section [Personal protective equipment](#) in Chapter [Safety](#).

 **NOTE**

Before opening the plate heat exchanger, check the warranty conditions. If in any doubt, contact the Alfa Laval sales representative. See Section [Warranty conditions](#) in Chapter [Introduction](#).

- 1 Open the plate package according to Section [Plate heat exchanger - Open](#).
- 2 Find the plates to be changed.
- 3 Tilt and gently lift out the plate from the carrying bar.
- 4 Check the gaskets for wear and damage. If glue-free gaskets are in good condition they can be moved from the old plates to the new plates.
- 5 Put the new gasketed plate in place on the carrying bar.
- 6 Close the plate package according to Section [Plate heat exchanger - Close](#).

4.3.2 Regasketing of a plate

! NOTE

Before opening the plate heat exchanger, check the warranty conditions. If in any doubt, contact the Alfa Laval sales representative. See Section [Warranty conditions](#) in Chapter [Introduction](#).

! NOTE

Before removing the old gaskets, check how they are attached.
Follow the procedure corresponding to your type of gasket.

The procedures in this section concern field gaskets, ring gaskets, and end gaskets. The gaskets can be assembled by the following methods:

- Glue free, called ClipGrip™ or Clip-on
- With help of double sided tape, called Clip-ad or Base-ad
- Glued

The majority of the gasket attachments are either completely glue free or glued. Only very few models use Clip-ad or Base-ad. In some special cases, also glue free gaskets do use some tape. See in the list below if any tape considerations need to be taken into account.

- ClipGrip™ or Clip-on use double sided tape in the following cases:
 - End plate II in cases when ready-made end plate field gasket is not available
 - Transition plate
 - Transition ring gasket
 - Semi-welded end cassette
- Clip-ad specifically for TL15-B, MX25-B, and MX25-M
- Base-ad specifically for T45-M, TS50-M, and T50-M

For the cases listed above, see the corresponding headlines for more information.

4.3.2.1 Use of double sided acrylic tape

The double sided acrylic tape, GC1, is applied with a roller in the gasket groove.

Neatly apply a single layer of tape. It is very important not to use multiple layers of tape (let the layers overlap) as this would add to the thickness. Carefully follow the instructions for the cases listed below on where to apply tape, as well as where not to apply any tape.

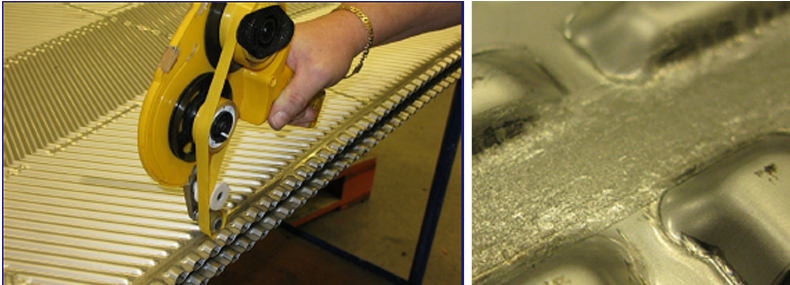

4.3.2.1.1 End plate II without end plate field gasket

If a special end plate gasket does not exist for the actual plate heat exchanger, an end plate gasket can be made of two field gaskets. Below shows an example of an end plate gasket cut from two field gaskets. The dashed lines show where it is allowed to use tape GC1. If possible, it should be avoided to tape where the gasket is attached with T-clips (at arrows). Taping around the rings in the port holes, where the gasket is in contact with the media, is not allowed. For more information, contact your local Alfa Laval representative for advice.

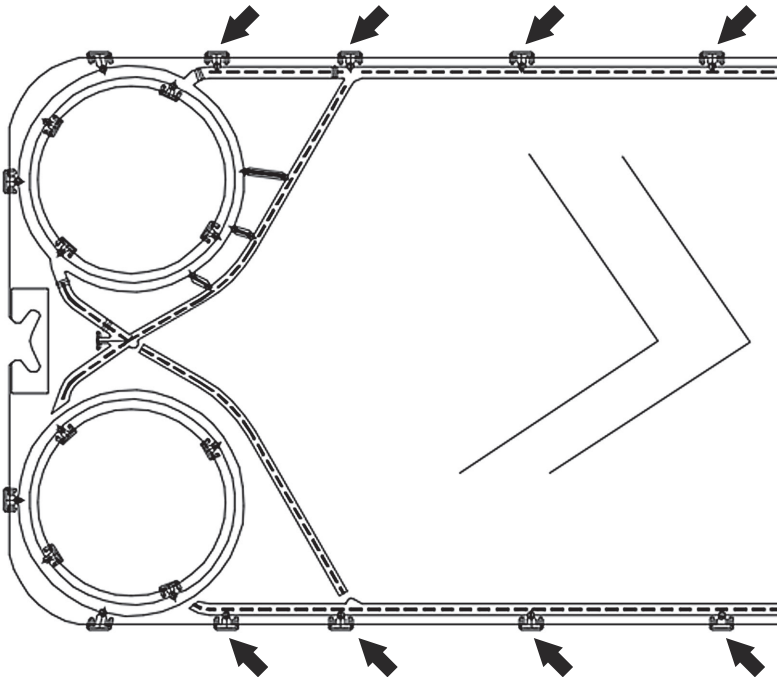

4.3.2.1.2 Transition plate

For transition plates, the same applies as for the end plates above. The only difference is that the rings are cut off and a special ring for transition plates is assembled. If no other attachment method is possible, it is in this case allowed to use tape GC1 around the rings. For more information, contact your local Alfa Laval representative for advice.

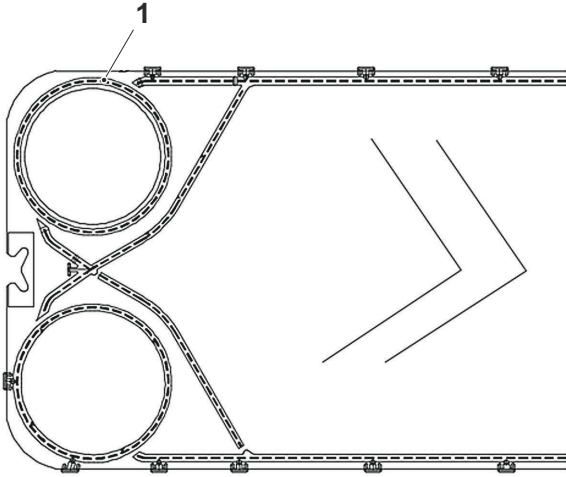

4.3.2.1.3 Transition ring gasket

A transition ring is used to seal towards the frame and is placed on the back side of end plate I. Since geometry differs for open and closed port, two designs exist for every plate. The marking piece on the gasket states in which port the gasket fits.

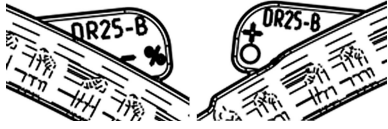

The ring gasket shall be placed so that the marking piece aligns with the gasket groove. Always secure that positioning is correct. An incorrectly placed gasket may cause leakage.

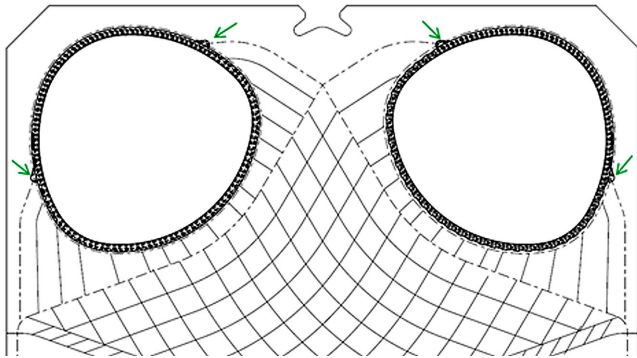

The transition ring gasket shall be attached with the double sided tape GC1 (1) between plate and gasket. The allowed area to tape can be seen bellow.

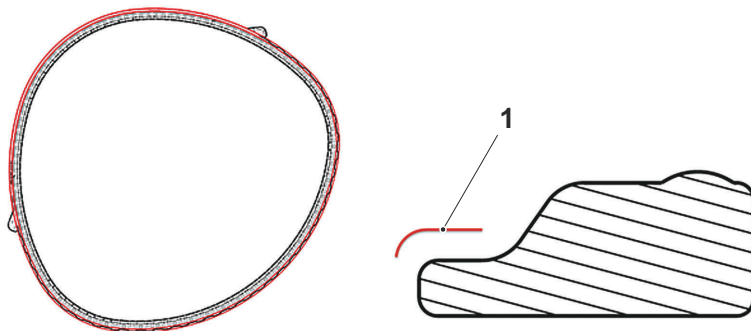

4.3.2.1.4 Semi-welded cassettes

To level the gap between the distance sheet and the linings, distance rings are taped on the end cassettes with GC1. It is very important not to use excessive amount of tape as this adds to the thickness of the distance rings and will make the compression of the rings insufficient. One layer on the cassette and one layer on the distance ring should be enough to keep the ring in place.

1. Distance ring gasket channel.
2. Distance ring welded channel.

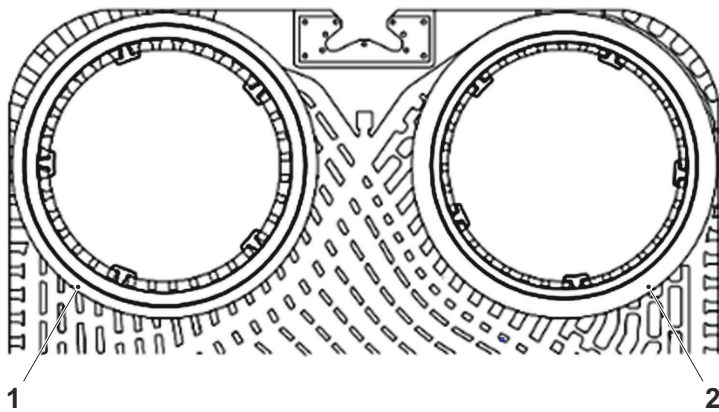

4.3.2.2 Plate — Change ClipGrip™ and Clip-on gaskets

CAUTION Risk of personal injury.

Plates and protection sheets have sharp edges.

Wear personal protective equipment when handling the plates and the protection sheets. See Section [Personal protective equipment](#) in Chapter [Safety](#).

NOTE

Before opening the plate heat exchanger, check the warranty conditions. If in any doubt, contact an Alfa Laval sales representative. See Section [Warranty conditions](#) in Chapter [Introduction](#).

- 1 Open the plate package according to Section [Plate heat exchanger - Open](#).
- 2 Remove the plates where the gasket must be changed. Follow Section [Plate - Change](#).
- 3 Remove the old gasket.
- 4 Make sure that all sealing surfaces are dry and clean.
- 5 Check the gasket and remove any rubber residual.

NOTE

Be especially thorough with the end plate gasket.

- 6 Place the gasket on the plate.
- 7 Fit the gasket clips under the edge of the plate.

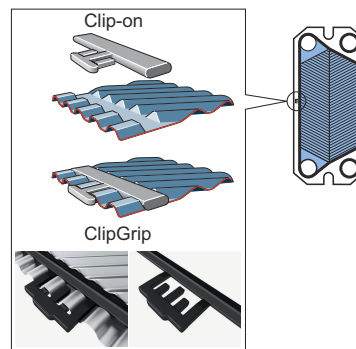

- 8 For semi-welded plate heat exchangers, there are three pieces of gaskets for each plate, one bigger field gasket and two ring gaskets for the port holes, see the images. If the ring gaskets (1) are for Omega port™, they must be positioned in a way so that one of the clips (2) is placed between the two dots (3) in the cassette.

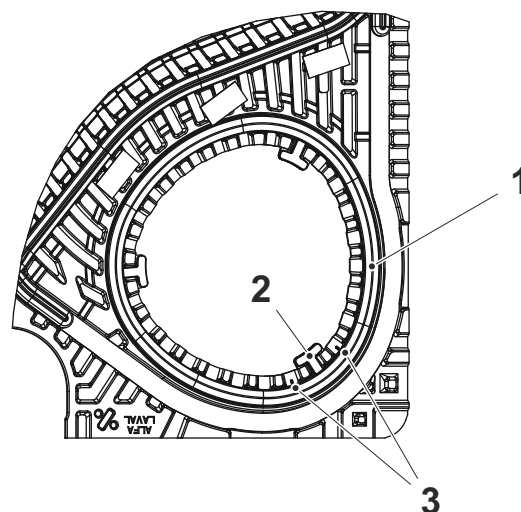
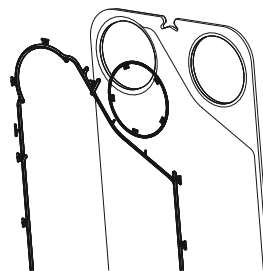

- 9 Repeat the procedure on all the plates that need to be regasketed.
- 10 Assemble the plate back to the carrying bar according to Section [Plate - Change](#).
- 11 Close the plate heat exchanger according to Section [Plate heat exchanger - Close](#).

4.3.2.3 Plate — Change Clip-ad and Base-ad gaskets

 **CAUTION** Risk of personal injury.

Plates and protection sheets have sharp edges.

Wear personal protective equipment when handling the plates and the protection sheets. See Section [Personal protective equipment](#) in Chapter [Safety](#).

 **NOTE**

Before opening the plate heat exchanger, check the warranty conditions. If in any doubt, contact an Alfa Laval sales representative. See Section [Warranty conditions](#) in Chapter [Introduction](#).

The Clip-ad gasket represents a system with Clip-on fastening around the ports and fastening by means of double sided tape along the sides of the plates.

The Base-ad gasket represents a system without any Clip-on fastening. Gasket fastening is done entirely with double sided tape.

The use of the double sided tape (GC1) is a simple way to obtain secure gasket positioning. It is adhered to the gasket groove by means of a special tape gun, making it easy to apply the tape exactly where wanted.

- 1 Open the plate package according to Section [Plate heat exchanger - Open](#).
- 2 Remove the plates where the gasket must be changed. Follow Section [Plate - Change](#).
- 3 Remove the old gasket.
- 4 It is not necessary to remove old tape as the film is very thin. Make sure, however, that the gasket groove is clean and dry.

- 5 Apply tape, using a tape gun.

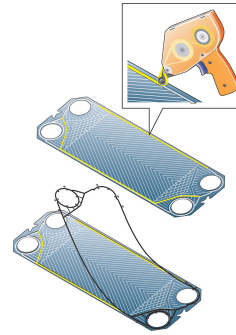

- a) **Valid for Clip-ad:** The tape on the long sides should be taped intermittently as this increases the pressure performance. The tape should stop 100 mm from open and closed diagonals to decrease crushing risk.

B-plates with Clip-ad is allowed to be taped in the diagonal, but M-plates should not be taped there due to the risk for gasket blow out.

- b) **Valid for Base-ad:** Base-ad is taped intermittently in the entire gasket groove.

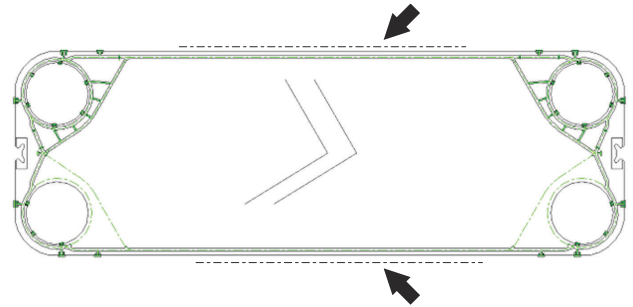

- 6 Attach the gasket to the plate. Fasten clips (if any) along the plate edges.
- 7 Repeat the procedure on all the plates that needs to be regasketed.
- 8 Assemble the plate back to the carrying bar according to Section [Plate - Change](#).
- 9 Close the plate heat exchanger according to Section [Plate heat exchanger - Close](#).

4.3.2.4 Plate — Change glued gaskets

Plates with glued gaskets that are delivered from Afa Laval's factories or Service Centers are glued with an oven-cured glue (GC6). For regasketing of a complete plate package with glued gaskets it is recommended to send the plates to a Service Center and use the services provided.

For regasketing of single plates, as a temporary solution, glues that don't need to be oven-cured (GC8 or GC11) can be used according to the procedures described below. It should be noted that these glues are not as durable as the oven-cured GC6.

Use glue recommended by Alfa Laval. Separate gluing instructions are delivered together with the glue.

 **CAUTION Risk of personal injury.**

Plates and protection sheets have sharp edges.

Wear personal protective equipment when handling the plates and the protection sheets. See Section [Personal protective equipment](#) in Chapter [Safety](#).

 **CAUTION Risk of damage to equipment.**

Other glues than those recommended can contain chlorides that can damage the plates.

 **CAUTION Risk of damage to equipment.**

To avoid damage to the plates, do not use sharp tools when removing the glued gasket .

 **NOTE Refrigeration**

On a semi-welded plate heat exchanger, glued gaskets are not allowed in the refrigerant side.

- 1 Open the plate package according to Section [Plate heat exchanger - Open](#).
- 2 Remove the plate where the gasket is to be changed. Follow Section [Plate - Change](#).
- 3 Remove the old gasket.
- 4 Make sure that the gasket groove is clean and dry.
- 5 Apply glue.
- 6 Attach the gasket to the plate.
- 7 Repeat the procedure on all the plates that are to be regasketed.
- 8 Assemble the plate back to the carrying bar according to Section [Plate - Change](#).

-
- 9 Close the plate heat exchanger according to Section *Plate heat exchanger - Close*.
-

This page is intentionally left blank.

5 Storage

If the plate heat exchanger is shut down and taken out of service for a long period of time, follow the precautions in this section.

NOTE

Until the expiration of the warranty period stipulated in the contract, Alfa Laval and its representatives reserve the right to inspect the storage space and equipment whenever necessary. Notification must be given 10 days prior to the date of inspection.

If there is any uncertainty about the storage of the plate heat exchanger, consult an Alfa Laval representative.

5.1 Taken out of service

It is recommended to store the plate heat exchanger indoors, but if this is not possible, make sure to protect the heat exchanger against the weather.

- Rinse and completely drain the heat exchanger.
- Depending on media used, consider drying of the heat exchanger.
- If the heat exchanger is disconnected from the piping system, cover the connections.
- Protect the heat exchanger from sun light, for example by covering with non-transparent plastic film. UV-light will shorten the lifetime of the rubber gaskets.
- The heat exchanger should not be exposed to ozone, organic solvents or acids. Avoid storage in engine rooms or close to welding equipment.
- The tightening and locking bolts should be well covered with a thin layer of grease. See Section [Close](#).
- Beware that extreme temperatures can shorten the lifetime of the gaskets.

Start-up after long-term out of service

If the plate heat exchanger has been taken out of service for an extensive period of time, the risk of leakage when starting up increases. To avoid this problem it is recommended to let the gasket rubber rest to regain most of its elasticity.

1. If the plate heat exchanger is not in position, follow the instructions in Chapter *Installation* in the *Installation Manual*.
2. Note the A-measurement.
3. Open the plate heat exchanger until the plate package measure is $1.25 \times A$. See Section [Open](#).
4. Leave the plate heat exchanger for 24–48 hours, the longer the better, for the gaskets to relax.
5. Re-tighten the tightening bolts and the locking bolts. See Section [Close](#).

Alfa Laval recommends to perform a leakage test, see Section [Leakage test](#).