

Note that all unique customer requirements (i.e tolerance) need to be verified thru Alfa Laval.

120

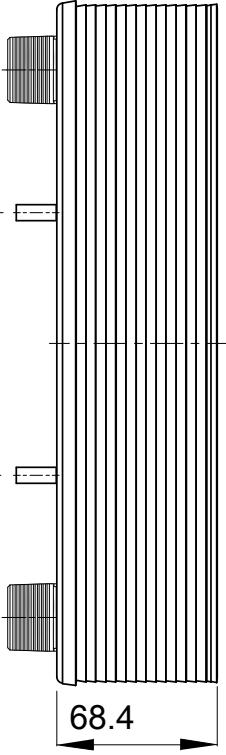

68.4

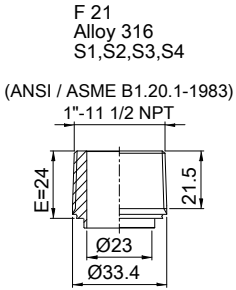

F 21
Alloy 316
S1,S2,S3,S4

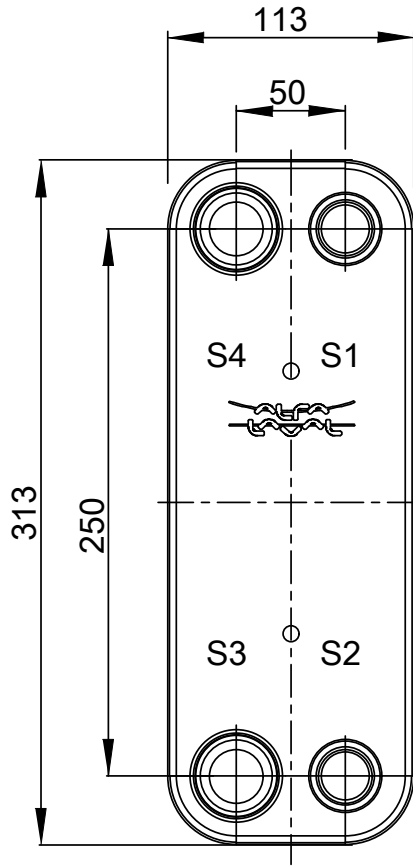

313

250

113

50

S4 S1

S3 S2

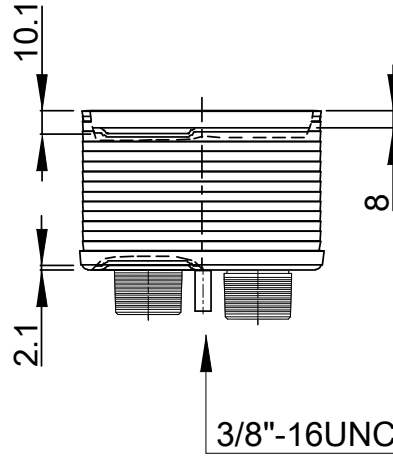

10.1

2.1

8

3/8"-16UNC x 25 (2x)

HEATING SURFACE
NETWEIGHT 4.2 kg
OPERATING WEIGHT kg
PLATE MATERIAL ALLOY 316
PLATE GROUPING 1*11L/1*12L

T1 T2 T3 T4 locations on back side correspond to S1 S2 S3 S4 on front side

ALL DIMENSIONS IN MILLIMETERS

SIDE	MEDIA	INLET	TEMP.	OUTLET	TEMP.	FLOW RATE	PRESSURE DROP	LIQUID VOL.
1		S1		S2				0.65 dm ³
2		S3		S4				0.59 dm ³

PRESSURE VESSEL APPROVAL

UL/CRN

CB30-24L (3287099367)

www.alfalaval.com

CUSTOMER NAME / REF. NO.

COMPANY / REF.

TOTAL LENGTH 94.4 mm
TOTAL WIDTH 113.0 mm
TOTAL HEIGHT 313.0 mm

4/16/2024
REV 0