

FRAME PLATE

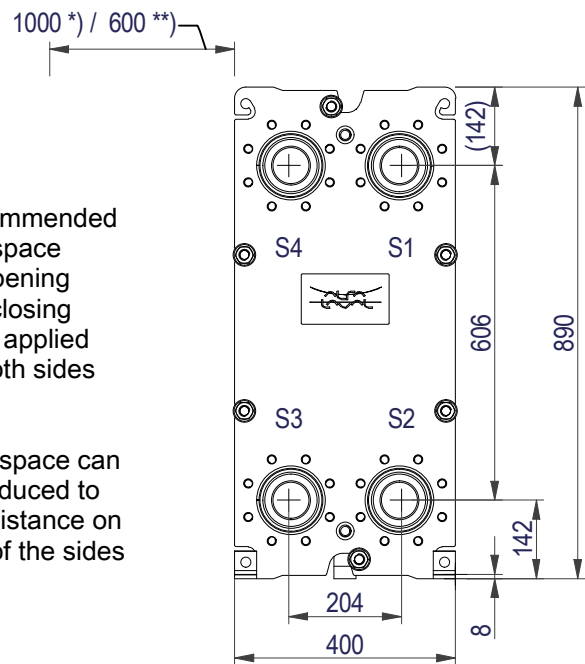

*) Recommended free space for opening and closing to be applied on both sides

**) Free space can be reduced to this distance on one of the sides

Space between pressure plate and supporting column should be kept free from fixed installations!

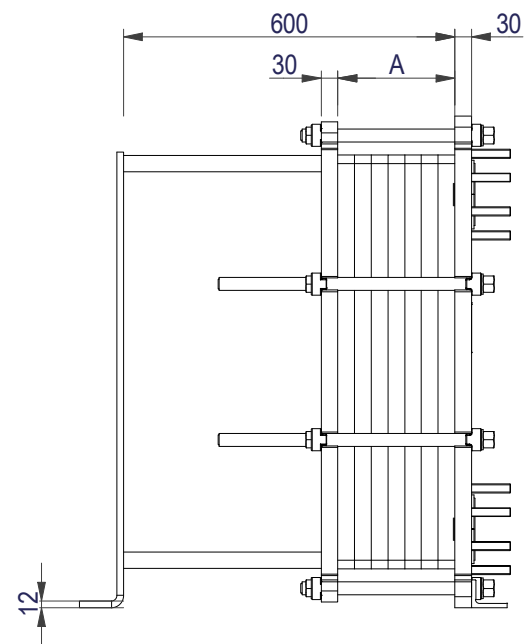

PRESSURE PLATE (MOVABLE)

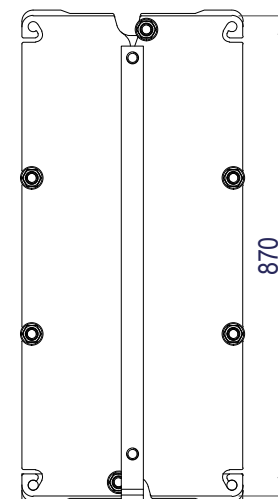

All dimensions in millimeters (mm)

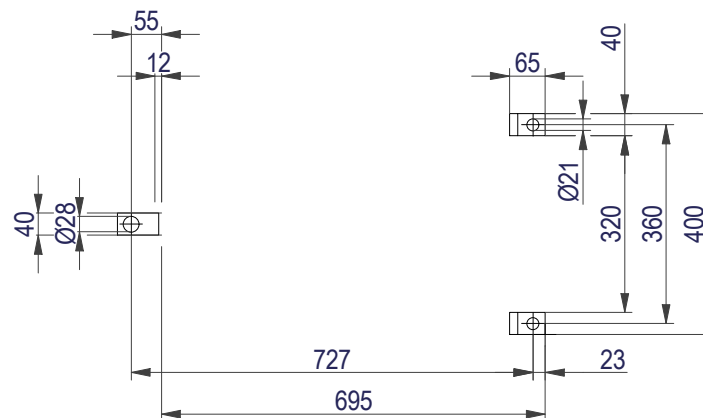
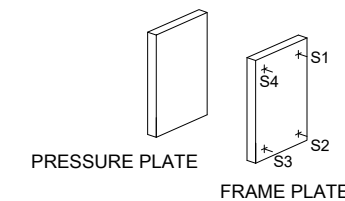
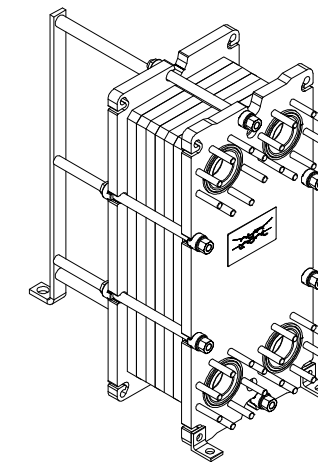

EN 1092-1 DN80 PN10
S1, S2, S3, S4

A-A:
NBRP / ALLOY 316

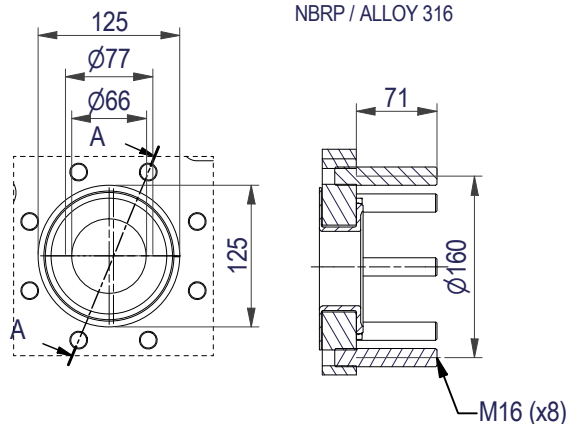

NO. OF UNITS 1

APPROX. OUTER DIMENSIONS

LENGTH	720 mm
WIDTH	410 mm
HEIGHT	900 mm

APPROX. WEIGHTS

NET WEIGHT, EMPTY	214 kg
WEIGHT FULL OF WATER	241 kg
PLATE MATERIAL	ALLOY 316
PLATE THICKNESS	0.5 mm
GASKET	NBRP ClipGrip™

CHANNEL ARRANGEMENT 1*20 MH / 1*19 ML



www.alfalaval.com

DRAWING
GASKETED PLATE HEAT EXCHANGER

T8-MFM

PED Category I

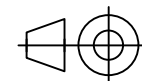

8230114017

Do not use this drawing for foundation bolting or piping layout

DATE 10/31/22
REVISION 0

This document and its contents are subject to copyrights and other intellectual property rights owned by Alfa Laval (pub) or any of its affiliates (Alfa Laval). No part of this document may be copied, reproduced or transmitted in any form or by any means, or for any purpose, without Alfa Laval's prior express written permission. Information and services provided in this document are made as a benefit and service to the user, and no representations or warranties are made about the accuracy or suitability of this information and these services for any purpose. All rights are reserved.