

Note that all unique customer requirements (i.e tolerance) need to be verified thru Alfa Laval

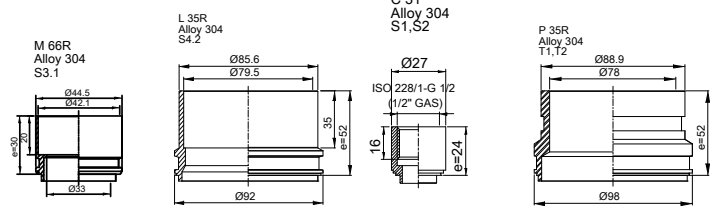
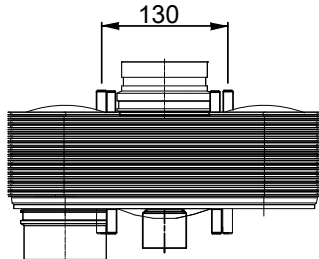
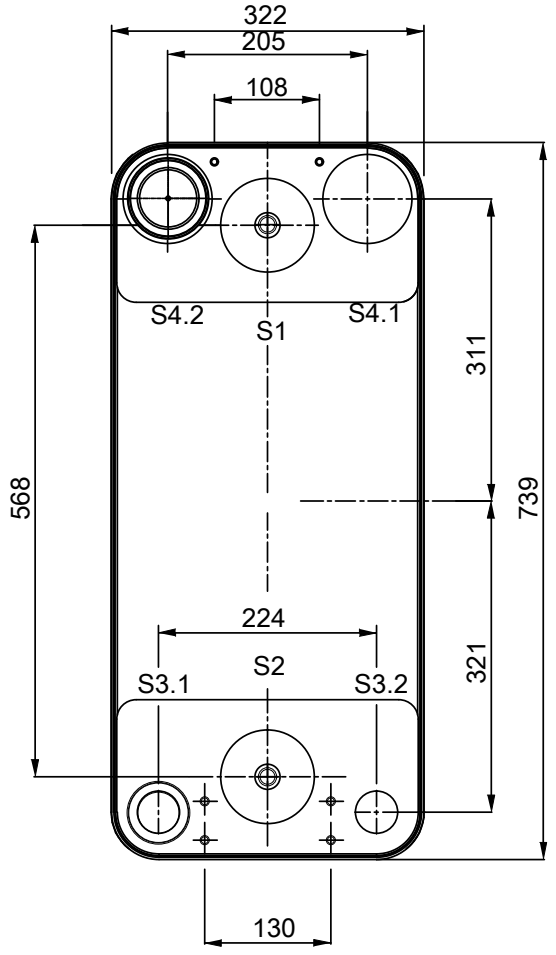
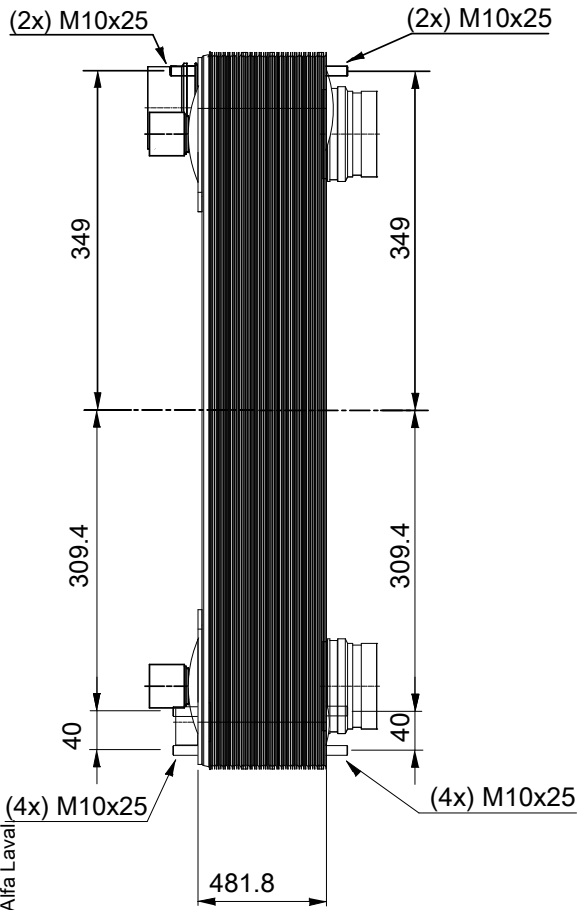

HEATING SURFACE
 NETWEIGHT 163.4 kg
 OPERATING WEIGHT kg
 PLATE MATERIAL ALLOY 316
 PLATE GROUPING 1*89HR/1*90HB

T1 T2 T3.1 T3.2 T4.1 T4.2 locations on back side correspond to S1 S2 S3.1 S3.2 S4.1 S4.2 on front side

ALL DIMENSIONS IN MILLIMETERS

SIDE	MEDIA	INLET	TEMP.	OUTLET	TEMP.	FLOW RATE	PRESSURE DROP	LIQUID VOL.
1		S1		S2				42.3 dm ³
2		S3.1		S4.2				44.5 dm ³



PRESSURE VESSEL APPROVAL PED
 AC-500EQ-180H-F (3287076467)

www.alfalaval.com

CUSTOMER NAME / REF. NO.

 COMPANY / REF.

TOTAL LENGTH 584.3 mm
 TOTAL WIDTH 322.0 mm
 TOTAL HEIGHT 739.0 mm



1/15/2024
 REV 0