

Note that all unique customer requirements (i.e tolerance) need to be verified thru Alfa Laval.

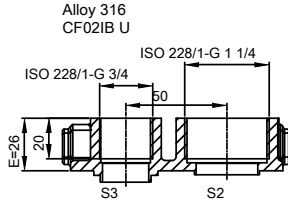

HEATING SURFACE  
 NETWEIGHT 4.2 kg  
 OPERATING WEIGHT kg  
 PLATE MATERIAL ALLOY 316  
 PLATE GROUPING 1\*8H/1\*9H

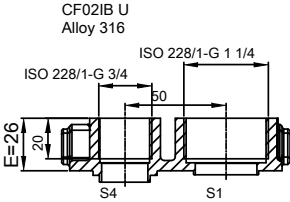
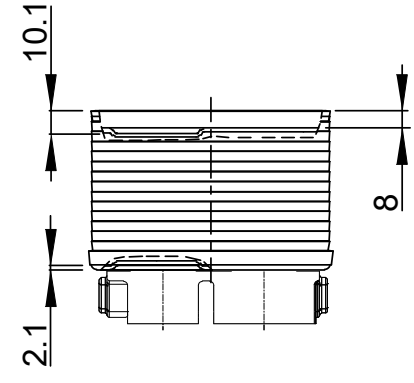
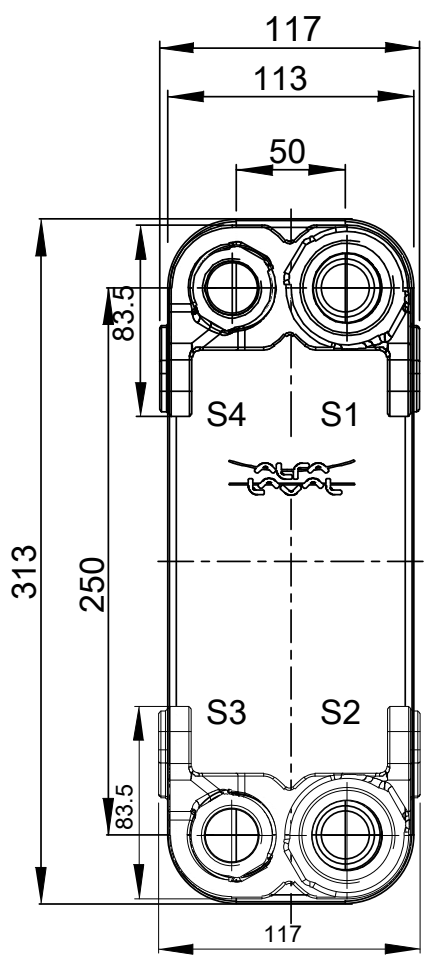
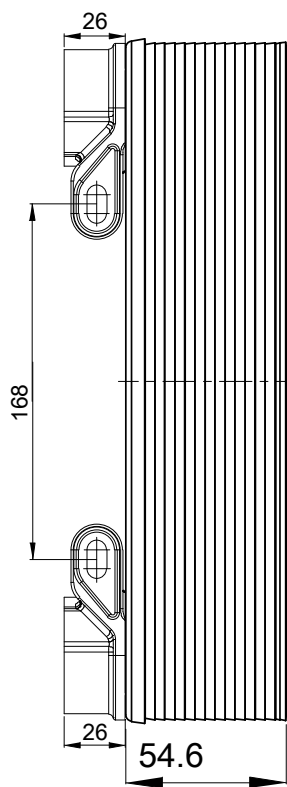

T1 T2 T3 T4 locations on back side correspond to S1 S2 S3 S4 on front side

ALL DIMENSIONS IN MILLIMETERS

SIDE	MEDIA	INLET	TEMP.	OUTLET	TEMP.	FLOW RATE	PRESSURE DROP	LIQUID VOL.
1		S1		S2				0.49 dm <sup>3</sup>
2		S3		S4				0.43 dm <sup>3</sup>



PRESSURE VESSEL APPROVAL PED  
 DOC30-18H-F (3287192724)

www.alfalaval.com

CUSTOMER NAME / REF. NO.  
  
 COMPANY / REF.

TOTAL LENGTH 80.6 mm  
 TOTAL WIDTH 113.0 mm  
 TOTAL HEIGHT 313.0 mm

4/16/2024  
 REV 0