

Note that all unique customer requirements (i.e tolerance) need to be verified thru Alfa Laval.

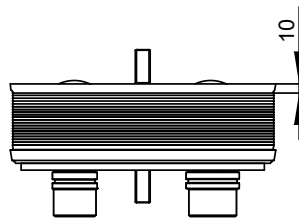
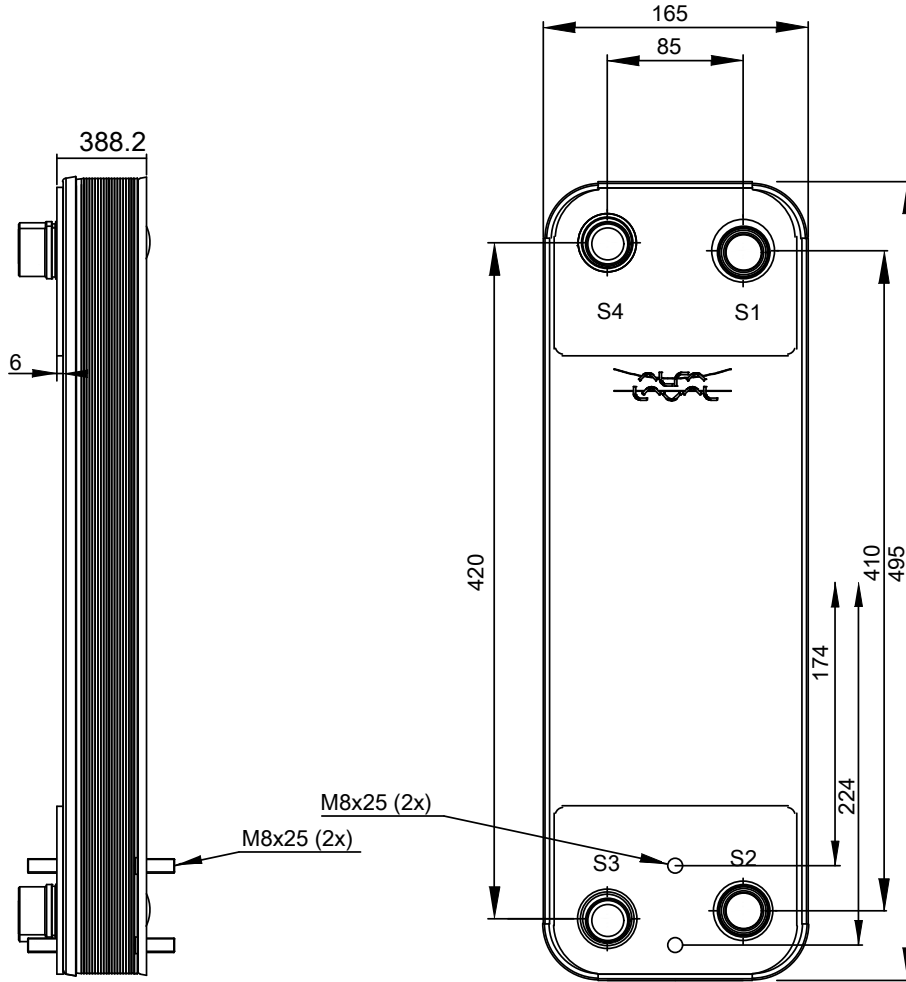
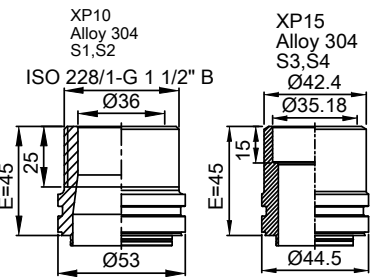

HEATING SURFACE
 NETWEIGHT 78.8 kg
 OPERATING WEIGHT kg
 PLATE MATERIAL ALLOY 316
 PLATE GROUPING 1*99MR/1*100MB

T1 T2 T3 T4 locations on back side
 correspond to S1 S2 S3 S4 on front side

ALL DIMENSIONS IN MILLIMETERS

SIDE	MEDIA	INLET	TEMP.	OUTLET	TEMP.	FLOW RATE	PRESSURE DROP	LIQUID VOL.
1		S1		S2				9.50 dm ³
2		S3		S4				9.40 dm ³

PRESSURE VESSEL APPROVAL

PED/UK



AXP82-200M-F (3075060403)

www.alfalaval.com

CUSTOMER NAME / REF. NO.

TOTAL LENGTH 454.0 mm
 TOTAL WIDTH 165.0 mm
 TOTAL HEIGHT 495.0 mm

COMPANY / REF.



4/16/2024
 REV 0