

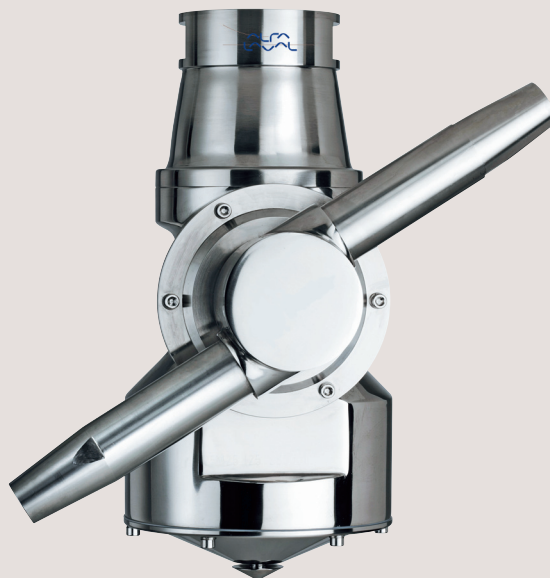

Spare Parts

Alfa Laval Rotary Jet Mixer IM 25



EPS00176-EN6 2017-01

Original manual

The information herein is correct at the time of issue but may be subject to change without prior notice

1. Alfa Laval IM 25 Rotary Jet Mixer	
Part drawing, part list, service kits and tools	4

Alfa Laval IM 25 Rotary Jet Mixer
Part drawing, part list, service kits and tools

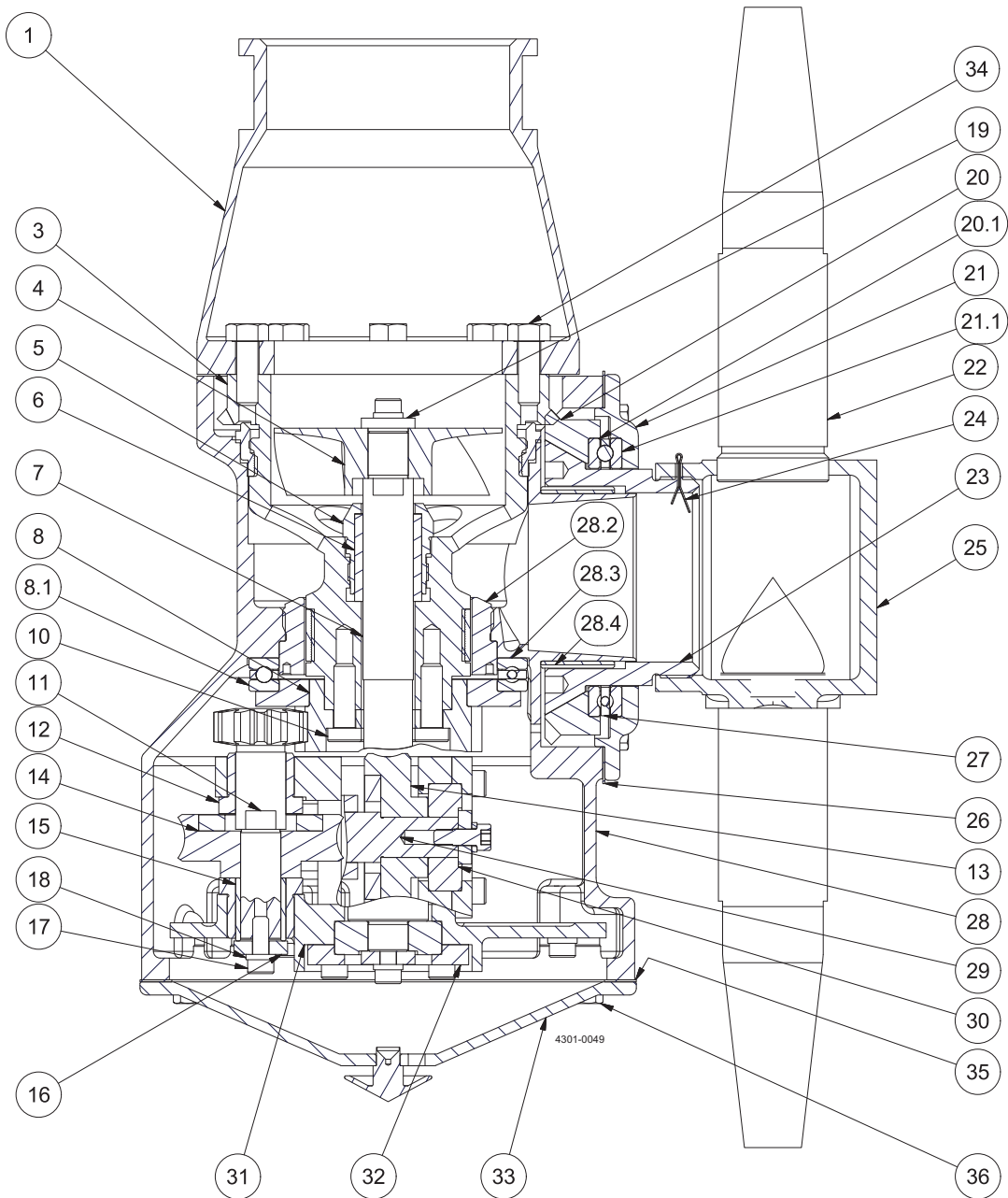

Alfa Laval IM 25 Rotary Jet Mixer
Part drawing, part list, service kits and tools

Pos	Qty	Denomination	Item no.	Material 1	Material 2	Remark
1	1	Top Cone 2½" BSP	TE33B510	Stainless steel		Spare part
3	1	Stem with liners	TEB604Z	Polymer	Stainless steel	Spare part
4	1	Impeller 100%	TE33B508	Stainless steel		Spare part
5	1	Gland	TE608Z	Stainless steel		Spare part
6 ♦	1	Main Bush	TE609P	Polymer		Wear part
7	1	Turbine shaft	TE32B511	Stainless steel		Wear part
8	1	Gear wheel w. Ball race	TE32B303	Stainless steel		Spare part
8.1 ♦	1	Ball race	TE32B510	Stainless steel		Wear part
10	6	Screw	TE120	Stainless steel		Spare part
11	1	Pinion	TE114	Stainless steel		Spare part
12 ♦	3	Collar bush	TE22A586	Polymer		Wear part
13 ♦	1	Worm wheel w. reinforcem.	TE22A365	Polymer	Stainless steel	Wear part
14 ♦	1	Worm wheel w. reinforcem.	TE22A364	Polymer	Stainless steel	Wear part
15	1	Journal	TE117	Stainless steel		Spare part
16	3	Washer	TE619A	Stainless steel		Spare part
17	17	Screw	TE118	Stainless steel		Spare part
18	9	Spring washer	TE156	Stainless steel		Spare part
19	1	Washer	TE32B515	Stainless steel		Spare part
20	1	Bevel gear w. Ball race	TE32B307	Stainless steel		Spare part
20.1♦	1	Ball race	TE32B510	Stainless steel		Wear part
21	1	Hub cover w. Ball race	TE32B306	Stainless steel		Spare part
21.1♦	1	Ball race	TE32B510	Stainless steel		Wear part
22 □	2	Nozzle, ø15	TE50C015	Stainless steel		Spare part
□	2	Nozzle, ø16	TE50C016	Stainless steel		Spare part
□	2	Nozzle, ø17	TE50C017	Stainless steel		Spare part
□	2	Nozzle, ø18	TE50C018	Stainless steel		Spare part
□	2	Nozzle, ø19	TE50C019	Stainless steel		Spare part
□	2	Nozzle, ø20	TE50C020	Stainless steel		Spare part
□	2	Nozzle, ø21	TE50C021	Stainless steel		Spare part
23	1	Hub conical part	TE32B534	Stainless steel		Spare part
24	1	Cotter Pin	TE448	Stainless steel		Spare part
25	1	Hub nozzle part	TE624215	Stainless steel		Spare part
26	1	Hub gasket	TE22D553	Modif. polymer	Elastomer	Spare part
27 ♦	2	Ball retainer w. balls	TE32B302	Polymer	Stainless steel	Wear part
28	1	Body		Stainless steel		*Note
28.2	1	Main collar lower	TE22E516	Stainless steel		Wear part
28.3♦	1	Ball race	TE32B510	Stainless steel		Wear part
28.4	1	Hub collar	TE33B575	Polymer		Wear part
29	1	Horizontal shaft, E-gear	TE128E	Stainless steel		Wear part
30 ♦	2	Slide Bearing	TE22A571	Polymer		Wear part
31	1	Gear frame	TE630	Stainless steel		Spare part
32	2	Bearing cover	TE531	Stainless steel		Spare part
33	1	Bottom cover	TE32B350	Stainless steel		Spare part
34	8	Screw	TE902H	Stainless steel		Spare part
35	1	Bottom gasket	TE22D554	Modif. polymer	Elatomer	Spare part
36	12	Screw	TE421H	Stainless steel		Spare part

Service kits

Spare part kit standard TE33B299

Parts marked with ♦ are included in the Standard Spare Part Kit standard: TE33B299

The machine can be delivered with ATEX certification.

□ Configuration according to delivery note/order.

*Note: Position 28 is not sold as single spare part component. Only sold as part of a machine maintenance/repair order. For further information please contact Alfa Laval Customer Support.

Alfa Laval IM 25 Rotary Jet Mixer
Part drawing, part list, service kits and tools

Service intervals

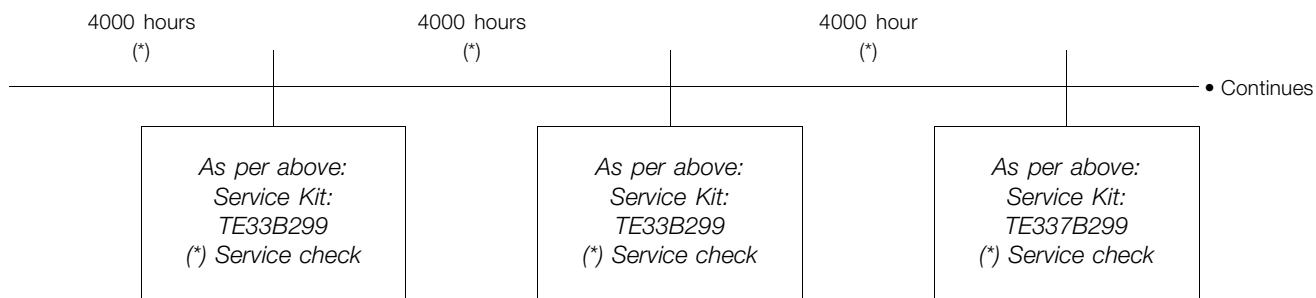

***Note:** The service intervals are recommended on the basis of pure liquids. When liquids contain particles and other kind of abrasives, we recommend shorter service intervals depending on the actual running conditions.

Standard Tool Kit, Article no. TE81B055

	<u>Qty x tool item no.</u>
Hex Key for 3/16" screw	1 x TE134
Hex Screwdriver unbraco for 5/32"	2 x TE134A
Hex Key for 1/4" screw	1 x TE135
Hex Screwdriver for 1/4" screw	1 x TE135A
Caliper	1 x TE369

How to contact Alfa Laval

Contact details for all countries are continually updated on our website.

Please visit www.alfalaval.com to access the information directly.

© Alfa Laval Corporate AB

This document and its contents is owned by Alfa Laval Corporate AB and protected by laws governing intellectual property and thereto related rights. It is the responsibility of the user of this document to comply with all applicable intellectual property laws. Without limiting any rights related to this document, no part of this document may be copied, reproduced or transmitted in any form or by any means (electronic, mechanical, photocopying, recording, or otherwise), or for any purpose, without the expressed permission of Alfa Laval Corporate AB. Alfa Laval Corporate AB will enforce its rights related to this document to the fullest extent of the law, including the seeking of criminal prosecution.